

C2648 Service Manual

Introduction

The design of this modular remote cuber is the result of years of experience with remote ice machine refrigeration systems. Standard features of this product include front accessible on-off switches, always-visible indicator lights, mechanical assist ice harvest for extra efficiency, automatically adjusting water purge and a control system that optimizes system operation.

The manual includes installation information, technical details, diagnostics and service parts.

Note the Caution and Warning symbols when they appear on the product or in this manual. They indicate potential hazards. Keep this manual for future reference.

Installation Table of Contents

| | |
|---|---------|
| Installation: Product Specifications | Page 2 |
| Model Number Description | Page 3 |
| Electrical and Refrigeration Requirements | Page 4 |
| Condenser and Ice Machine Layouts | Page 5 |
| Water | Page 6 |
| Panel Removal | Page 7 |
| Remote Condenser Location | Page 8 |
| For The Installer: Remote Condenser | Page 9 |
| Precharged Line Routing | Page 10 |
| Coupling Instructions | Page 11 |
| Plumbing Requirements | Page 12 |
| Electrical | Page 13 |
| Final Check List: | Page 14 |
| Initial Start Up | Page 15 |
| Adjustments | Page 16 |
| Use and Operation | Page 17 |
| Switch Panel Area | Page 18 |
| Options and Other Information | Page 19 |
| Cleaning, Sanitation and Maintenance | Page 20 |
| Remote condenser and other maintenance | Page 22 |
| Prodigy Cuber System Information | Page 23 |

C2648 Service Manual - Installation

Installation: Product Specifications

Location Limitations

This ice system is made up of three parts, the ice making machine, or head; the remote condenser; and the interconnecting tubing. The ice making machine must be installed indoors, in a controlled environment. Space must be provided near the machine for service access. The remote condenser may be installed above or below the ice machine, per the limits stated later in this manual. The remote condenser may be installed outdoors within the temperature limits listed below. The interconnecting tubing must be installed per the directions stated in this manual, and the amount of tubing exposed to uncontrolled temperatures must be minimized.

Space Limitations

Although the machine will function with no clearance to the top and sides, some space must be allowed for service access. Building the machine in with no access will cause higher service cost, in many cases this extra cost may not be covered by warranty.

Environmental Limitations, ice machine:

| | Minimum | Maximum |
|-------------------|---------|---------|
| Air temperature | 50°F. | 100°F. |
| Water temperature | 40°F. | 100°F. |
| Water pressure | 20 psi | 80 psi |

Note: While the ice machine will operate under the listed conditions, ice making capacity will be reduced with increases in water supply temperature and/or air temperatures at the condenser. Bin meltage will also increase with any increase in room temperature.

Remote condenser

| | Minimum | Maximum |
|-----------------|---------|---------|
| Air temperature | -20°F. | 120°F. |

Power Supply

| | Minimum | Maximum |
|--------------------|-----------|-----------|
| 208-230 volt model | 198 volts | 253 volts |

Warranty Information

The warranty statement for this product is provided separately from this manual. Refer to it for applicable coverage. In general warranty covers defects in material and workmanship. It does not cover maintenance, corrections to installations, or situations when the ice machine is operated in circumstances that exceed the limitations printed above.

Product Information

The machine is a specialized version of a modular cuber. A modular cuber does not include any ice storage, it is designed to be placed onto an ice storage bin. Many installations only require the matching bin, but some may need an adapter to be placed between the ice machine and the bin. Additionally, the machine must be connected to the correct remote condenser and use the correct pre-charged tubing. The machine is supplied with a full refrigerant charge, field charging is not required.

This product cannot be stacked.

C2648 Service Manual - Installation

Model Number Description

Example

- C2648SR-3A
- C=cuber
- 24=nominal capacity in 100s of pounds
- 48=nominal width of cabinet in inches
- S=cube size, S=small or half dice, M=medium or full dice
- R=condenser type. R=Remote
- -3=Electrical code. = 208-230/60/3
- A=series revision code. A=first series.

Note: In some areas of this manual model numbers may include only the first five characters of the model number, meaning that cube size, condenser type and voltage differences are not critical to the information listed there.

Options:

There are several options available for field installation. They include:

- Vari-Smart™ Adjustable ice level system
- Smart-Board™ Advanced feature control

Some installations require bin or dispenser adapters. See the table below.

Standard bin applications – Adapter information

| Model | BH1100, BH1300 or BH1600 |
|-------|---|
| C2648 | Adapter panels included with bin, no adapter needed |

Other bins and applications:

Take note of the depth of the machine. Slope front bins may not be deep enough to allow the bin door to rest open against the machine. **Upright bins are recommended.**

Note the drop zone and optional ultrasonic sensor locations in the illustrations. **Drop zone hole must be 20.25" deep.**

Scotsman ice systems are designed and manufactured with the highest regard for safety and performance. They meet or exceed the standards of UL and NSF.

Scotsman assumes no liability of responsibility of any kind for products manufactured by Scotsman that have been altered in any way, including the use of any part and/or other components not specifically approved by Scotsman.

Scotsman reserves the right to make design changes and/or improvements at any time. Specifications and design are subject to change without notice.

C2648 Service Manual - Installation

Electrical and Refrigeration Requirements

| Ice Machine Dimensions w" x d" x h" | Model | Electrical | Use condenser | Minimum Circuit Ampacity | Maximum Fuse* Size | Suggested Fuse* Size |
|--|-----------|--------------|---------------|--------------------------|--------------------|----------------------|
| 48 x 28 x 31 | C2648SR-3 | 208-230/60/3 | PRC241-32A | 21.6 | 30 | 30 |
| same | C2848MR-3 | 208-230/60/3 | PRC241-32A | 21.6 | 30 | 30 |

Remote Condenser Footprint: On center mounting hole spread: 27.57" w x 33.38" d. See page 5.

Minimum bin top opening: 20.5" x 40.5" includes drop zones and ultrasonic sensor location. See page 5.

*Or HACR circuit breakers.

Table notes: Series revision code omitted. All the listed condensers include a headmaster valve.

Ratings include the remote condenser motor, as it is designed to be powered by the ice machine. If connecting remote condenser independently of the ice machine, use the information on the condenser's dataplate for fuse and wire sizes.

Condensers are UL listed for these model ice machines.

Central Condenser (Rack) Coils

The ice machine may be connected to a central condenser coil. The requirements are:

- Coil – not previously used with mineral oil system. Virgin coil preferred.
- Correct size (internal volume) and capacity (BTUH). Contact Scotsman for data.
- Includes a headmaster valve for discharge pressure control rated at 217 PSIG.
- Fan motor on all the time or controlled to be on whenever the ice machine is operating.
- U.L. listed for the ice machine
- Non-Scotsman condensers must have prior Scotsman Engineering approval for warranty coverage to be in effect.

Precharged tubing kits:

The ice making head's and the remote condenser's refrigeration circuits must be connected. They are designed to be connected using precharged refrigerant tubing, supplied in kits of liquid and discharge tubes. Several lengths are available, order the one that just exceeds the length needed for the site.

| | 10' | 20' | 40' | 75' |
|-------|--------|--------|--------|--------|
| C2648 | RTEL10 | RTEL25 | RTEL40 | RTEL75 |

No additional refrigerant is required.

C2648 Service Manual - Installation

Condenser and Ice Machine Layouts

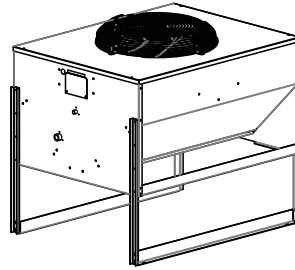
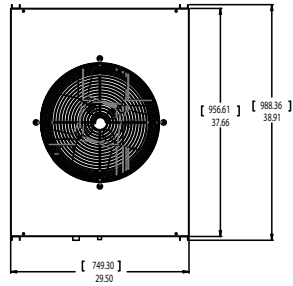

PRC241-32A

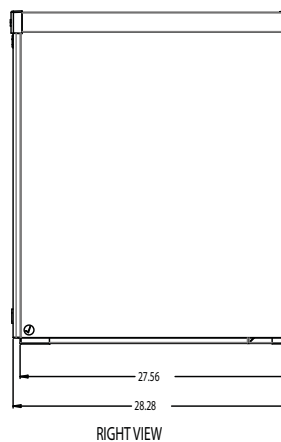
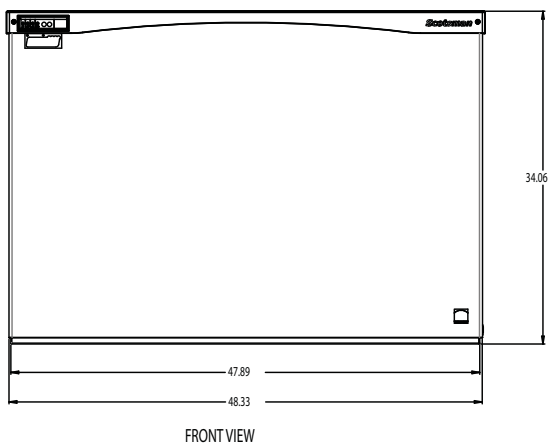
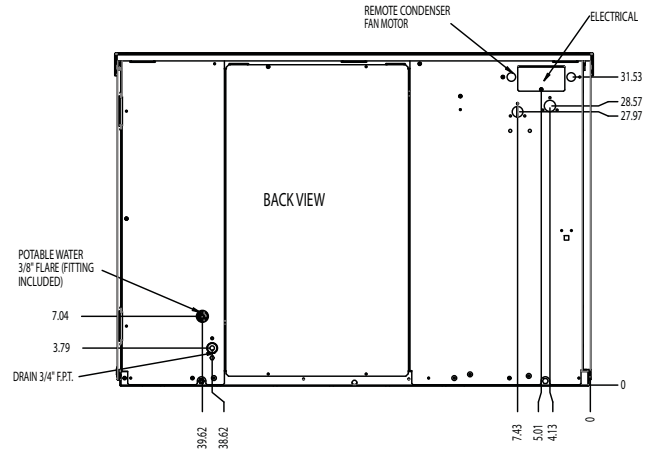
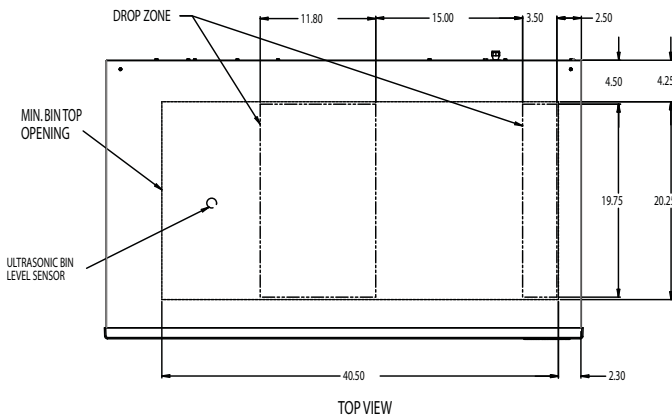
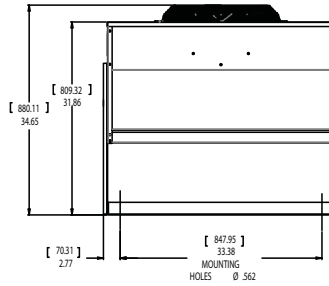
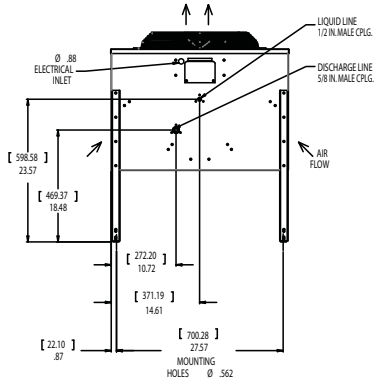

C2648 Service Manual - Installation

Water

The quality of the water supplied to the ice machine will have an impact on the time between cleanings and ultimately on the life of the product. There are two ways water can contain impurities: in suspension or in solution. Suspended solids can be filtered out. In solution or dissolved solids cannot be filtered, they must be diluted or treated.

Water filters are recommended to remove suspended solids. Some filters have treatment in them for suspended solids. Check with a water treatment service for a recommendation.

Scotsman filters:

A triple head filter is recommended. Either the Scotsman SSM3 taste and odor filter system, or the ADS-AP3 AquaPatrol system.

Water flow is 2.5 GPM when filling the reservoir.

RO water:

This machine can be supplied with Reverse Osmosis water, but the water conductivity must be no less than 10 microSiemens/cm.

Potential for Airborne Contamination

Installing an ice machine near a source of yeast or similar material can result in the need for more frequent sanitation cleanings due to the tendency of these materials to contaminate the machine. Most water filters remove chlorine from the water supply to the machine which contributes to this situation. Testing has shown that using a filter that does not remove chlorine, such as the Scotsman Aqua Patrol, will greatly improve this situation, while the ice making process itself will remove the chlorine from the ice, resulting in no taste or odor impact. Additionally, devices intended to enhance ice machine sanitation, such as the Scotsman Aqua Bullet, can be placed in the machine to keep it cleaner between manual cleanings.

Water Purge

Cube ice machines use more water than what ends up in the bin as ice. While most water is used during ice making, a portion is designed to be drained out every cycle to reduce the amount of hard water scale in the machine. That's known as water purge, and an effective purge can increase the time between needed water system cleaning.

In addition, this product is designed to automatically vary the amount of water purged based on the purity of the water supplied to it. The water purge rate can also be set manually. Adjustments of purge due to local water conditions are not covered by warranty.

C2648 Service Manual - Installation

Panel Removal

1. Locate and loosen the two screws at the front edge of the top panel.
2. Pull the front panel out at the top until it clears the top panel.
3. Lift the front panel up and off the machine.
4. Remove two screws from the front edge of the top panel.
5. Lift up the front of the top panel, push it back an inch, then lift to remove.
6. Locate and loosen the screw holding each side panel to the base.
7. Pull the side panel forward to release it from the back panel.

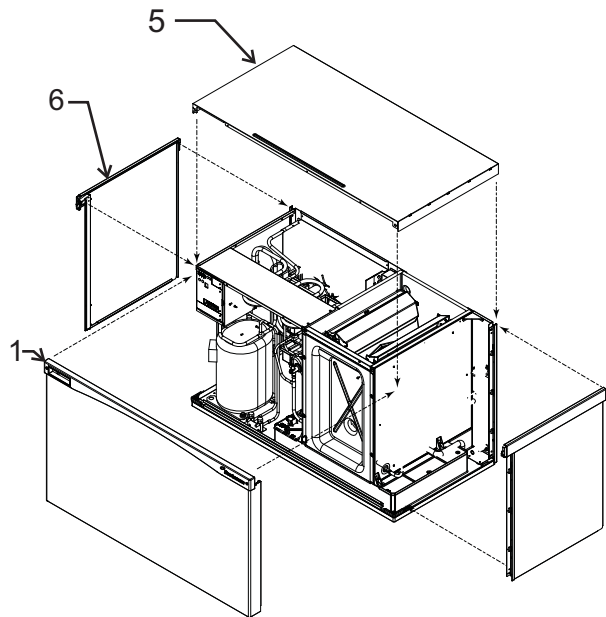

Panel Removal

The model number on the ice machine can be found either on the dataplate, which is on the back panel, or the serial number tag, which is behind the front panel. See the illustration for the locations of the dataplate and the serial number tag.

The remote condenser has a separate model and serial number. Its model and serial number is on the dataplate on the condenser near the quick connect fittings.

Uncrate and Set Up

Begin with the ice storage bin. Uncrate and attach legs. Check the bin top gasket for tears or gaps. If recycling an older bin, replace the gasket or repair with food grade sealant prior to placing the ice machine on the bin.

Install the bin top adapter if one is required for the application.

If the ice machine has not been unpacked, do so now. Remove the carton from the skid. Cut away any shipping strapping. Lift the ice machine off the skid directly onto the bin.

Note: The machine is heavy. Use a mechanical lift. If lifting from the front, be sure that fork tines are under the front and back of the cabinet. If lifting from the side, be sure to have tines under the front and back. Do not lift on the sump bottom.

Scotsman BH1100, BH1300, BH1600: Position back of ice machine 2 3/8" from back of bin.

Secure the ice machine to the bin with the hardware provided (two metal Z straps and four bolts).

C2648 Service Manual - Installation

Remote Condenser Location

Use the following for planning the placement of the condenser relative to the ice machine

Location Limits - condenser location must not exceed ANY of the following limits:

- Maximum rise from the ice machine to the condenser is 35 physical feet
- Maximum drop from the ice machine to the condenser is 15 physical feet
- Physical line set maximum length is 100 feet.
- Calculated line set length maximum is 150.

Calculation Formula:

- Drop = $dd \times 6.6$ (dd = distance in feet)
- Rise = $rd \times 1.7$ (rd = distance in feet)
- Horizontal Run = $hd \times 1$ (hd = distance in feet)
- Calculation: Drop(s) + Rise(s) + Horizontal Run = $dd+rd+hd$ = Calculated Line Length

Configurations that do NOT meet these requirements must receive prior written authorization from Scotsman.

Do NOT:

- Route a line set that rises, then falls, then rises.
- Route a line set that falls, then rises, then falls.

Calculation Example 1:

The condenser is to be located 5 feet below the ice machine and then 20 feet away horizontally.

$5 \text{ feet} \times 6.6 = 33$. $33 + 20 = 53$. This location would be acceptable

Calculation Example 2:

The condenser is to be located 35 feet above and then 100 feet away horizontally. $35 \times 1.7 = 59.5$. $59.5 + 100 = 159.5$. 159.5 is greater than the 150 maximum and is NOT acceptable.

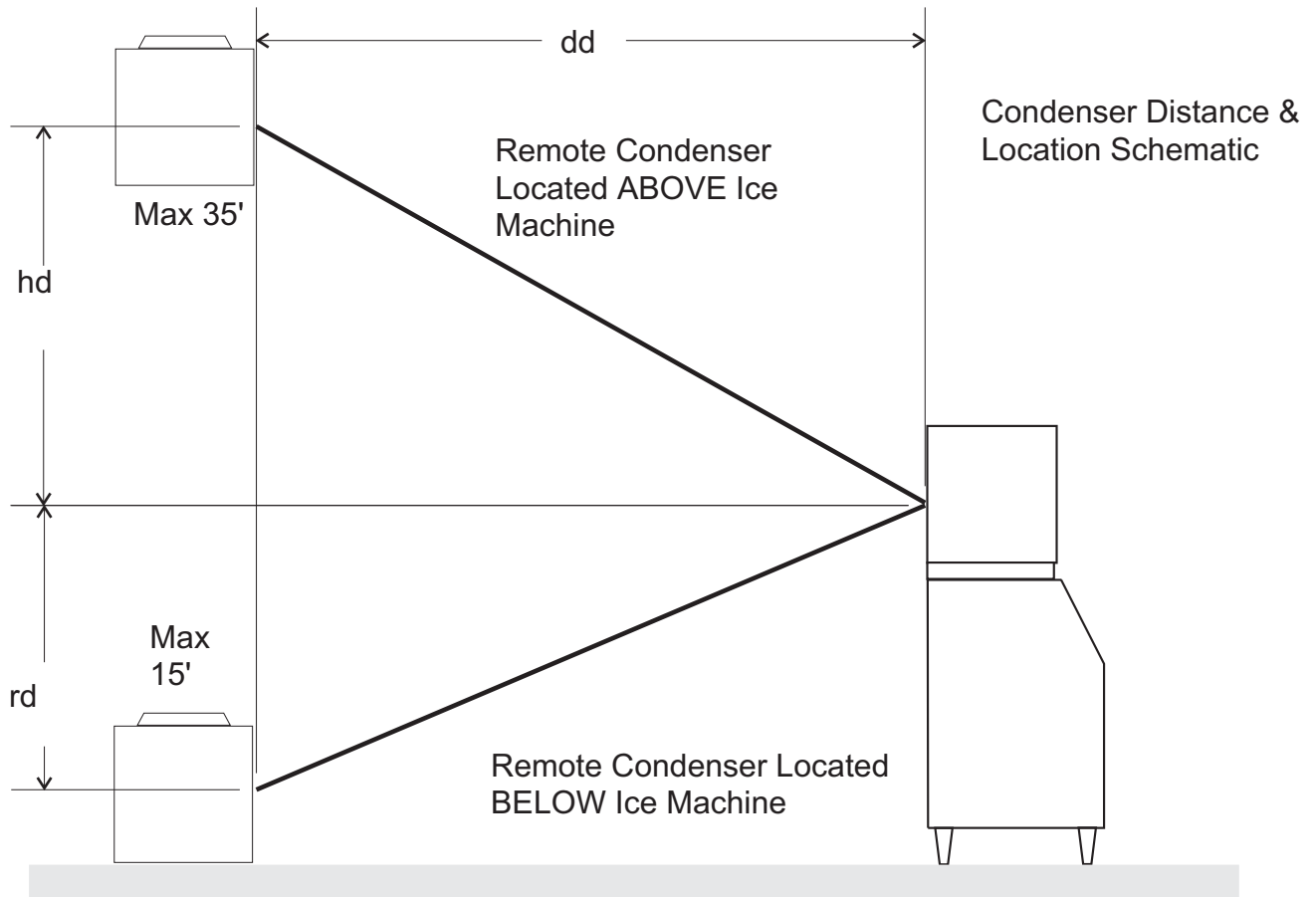

C2648 Service Manual - Installation

For The Installer: Remote Condenser

Locate the condenser as near as possible to the interior location of the ice machine.

Note: The location of the condenser relative to the ice machine is LIMITED by the specification on the prior page.

Meet all applicable building codes.

Roof Attachment

Install and attach the remote condenser to the roof of the building, using the methods and practices of construction that conform to the local building codes, including having a roofing contractor secure the condenser to the roof.

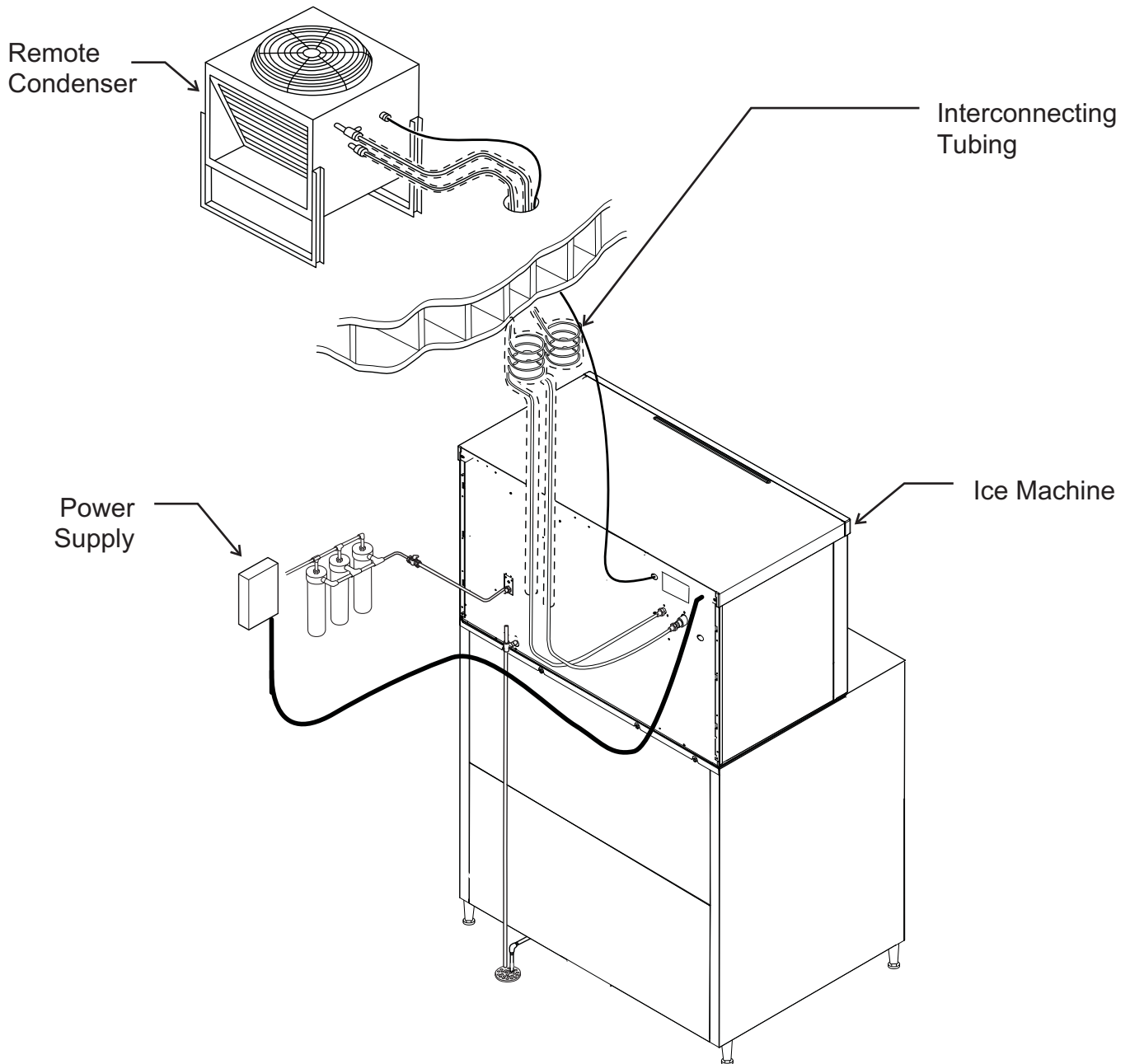

Remote Condenser, Typical System Illustration

C2648 Service Manual - Installation

Precharged Line Routing

Do not connect the precharged tubing until all routing and forming of the tubing is complete. See the Coupling Instructions for final connections.

1. Each set of pre-charged tubing lines contains a 1/2" diameter liquid line, and a 5/8" diameter discharge line. Both ends of each line have quick connect couplings, the end without access valves goes to the ice maker.

Note: The openings in the building ceiling or wall, listed in the next step, are the minimum sizes recommended for passing the refrigerant lines through.

2. Have the roofing contractor cut a minimum hole for the refrigerant lines of 2". Check local codes, a separate hole may be required for the electrical power supply to the condenser.

Caution: Do NOT kink the refrigerant tubing while routing it.

3. Route the refrigerant tubes thru the roof opening. Follow straight line routing whenever possible. Excess tubing may EITHER be coiled up INSIDE the building OR cut out prior to connection to the ice maker and condenser.

If the excess tubing is cut out, after re-brazing the tubing must be evacuated prior to connection to the ice maker or condenser.

If the excess tubing is to be coiled, spiral it horizontally to avoid excess trapping in the lines.

5. Have the roofing contractor seal the holes in the roof per local codes

Best Practice: Coil excess tubing inside the building in a

Minimize tubing routed outside of the

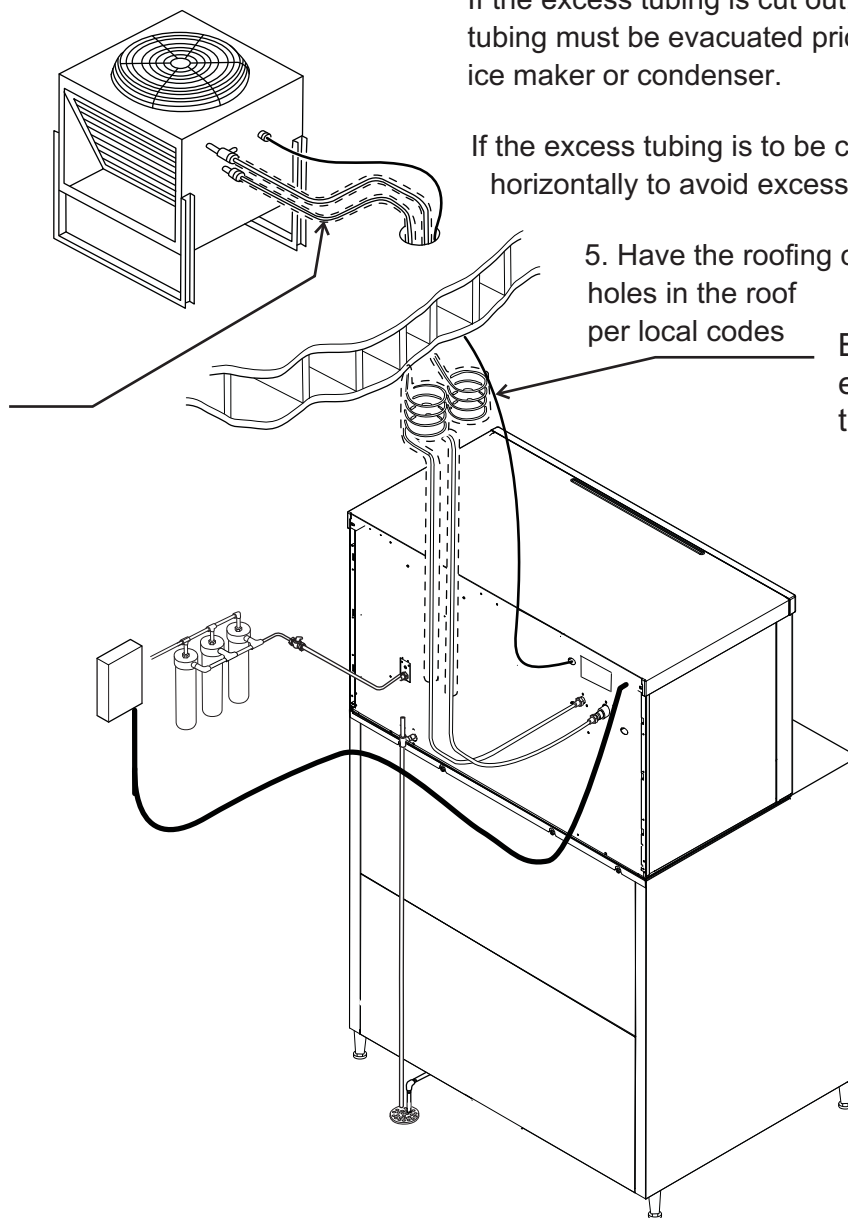

C2648 Service Manual - Installation

Coupling Instructions

The couplings on the ends of the pre-charged line sets are self-sealing when installed properly. Follow these instructions carefully.

These steps must be performed by an EPA Certified Type II or higher technician.

Initial Connections

1. Remove the protector caps and plugs. Wipe the seats and threaded surfaces with a clean cloth to remove any possible foreign matter.



2. Lubricate the inside of the couplings, especially the O-rings, with refrigerant oil.

3. Position the fittings on the correct connections on the condenser and ice machine.

- The discharge line goes to the remote condenser fitting marked "discharge line".
- The 1/2" liquid line goes to the remote condenser fitting marked "liquid line".
- The discharge line goes to the ice maker fitting marked "discharge line".
- The 1/2" liquid line goes to the ice maker fitting marked "liquid line".

Final Connections:

4a. Begin by tightening the couplings together by hand until it is certain that the threads are properly engaged.

4b. Then using two wrenches tighten the coupling until it bottoms out or a definite increase in resistance is felt.

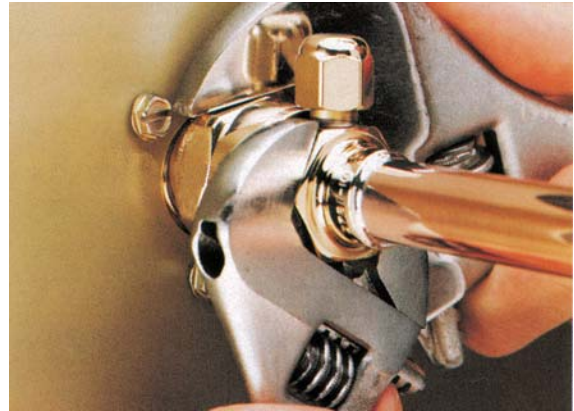

It is important that **ONLY** the nut on the pre-charged tube be turned, or the diaphragms will be torn out by the piercing knives and they will be loose in the refrigeration system. Note: As the couplings are tightened, the diaphragms in the quick connect couplings will begin to be pierced. As that happens, there will be some resistance to tightening the swivel nut.

4c. Continue tightening the swivel nut until it bottoms out or a very definite increase in resistance is felt (no threads should be showing).

5. Use a marker or pen to mark a line on the coupling nut and unit panel. Then tighten the coupling nut an additional one-quarter turn. The line will show the amount that the nut turns. Do **NOT** over tighten.



6. After all connections have been made, and after the king valve has been opened (do not open yet), check the couplings for leaks.

C2648 Service Manual - Installation

Plumbing Requirements

All models require connection to cold, potable water. A hand actuated valve within site of the machine is required. There is a single 3/8" flare nut inlet water connection, and a 3/8" to 3/8" flare union is supplied with the machine and can be used if desired.

Water Filters Install a new cartridge if the filters were used with a prior machine.

Drains

All models require drain tubing to be attached to them. There is a single 3/4" FPT drain fitting in the back of the cabinet.

Install new tubing when replacing a prior ice machine, as the tubing will have been sized for the old model and might not be correct for this one.

1. Connect water supply to water inlet fittings.
2. Connect drain tubing to drain fitting.
3. Route the drain tubing to building drain. Follow local codes for air gap.
4. Use rigid drain tubes and route them separately – do not Tee into the bin's drain.

Vent the reservoir drain. A vertical vent at the back of the drain, extended about 8 – 10" will allow the gravity drain to empty and also keep any surges during draining from discharging water.

Horizontal runs of drain tubing need a 1/4" per foot of run for proper draining.

Follow all applicable codes.

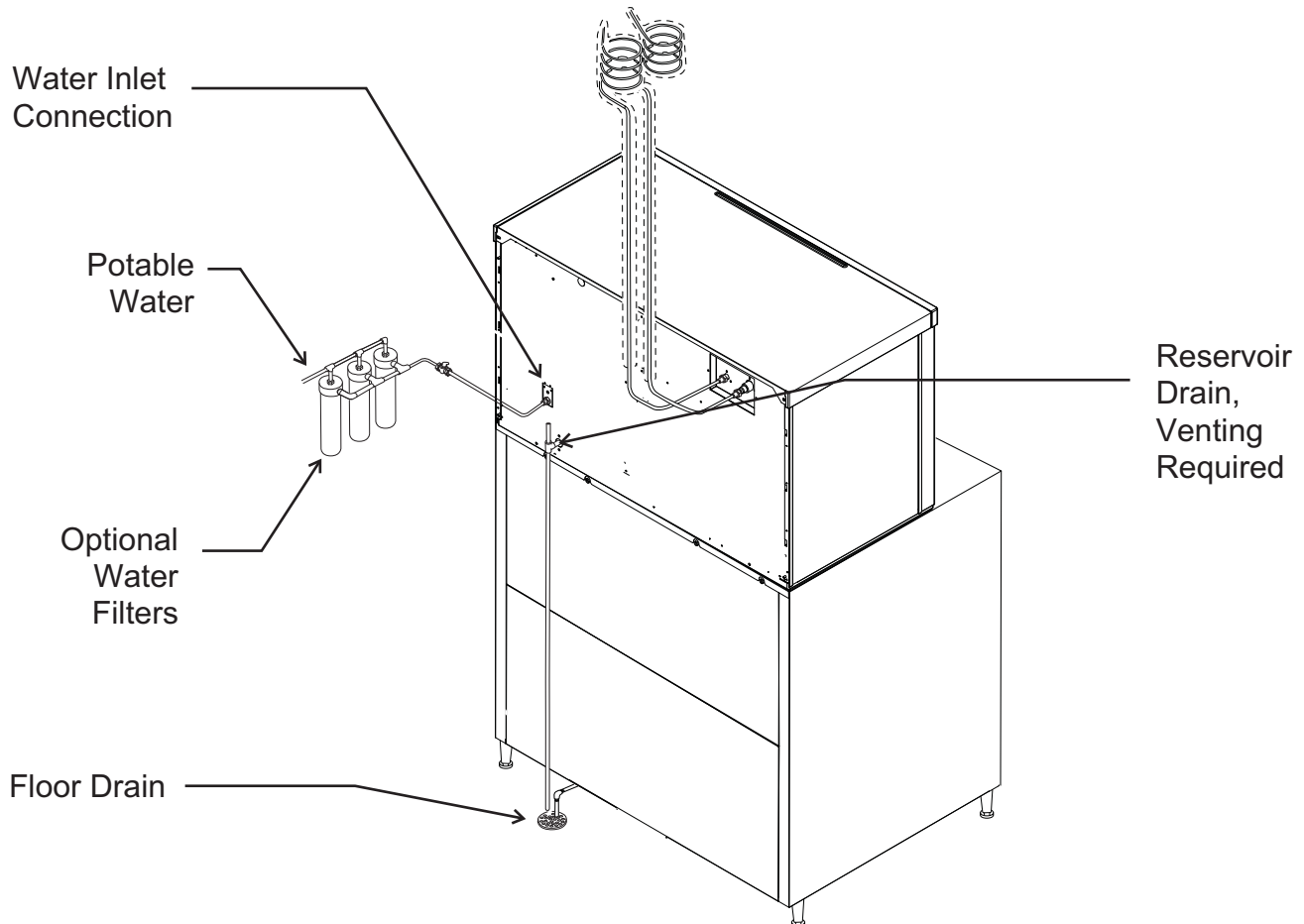

Water Supply and Drain Connections

C2648 Service Manual - Installation

Electrical

The machine is not supplied with a power cord, one must either be field installed or the machine hard-wired.

The dataplate on the back of the cabinet details the power requirements, including voltage, phase, minimum circuit ampacity and maximum fuse size. HACR type circuit breakers may be used in place of fuses. Extension cords are not permitted. Use of a licensed electrician is recommended.

The ice maker is designed to operate on its own electrical circuit and must be individually fused. Voltage variation must not exceed the limits listed earlier.

The remote condenser is designed to be powered from the ice machine. A separate knockout hole has been provided near the ice maker electrical junction box.

Electrical connections are made inside the junction box in the back panel of the ice machine.

1. Remove the junction box cover and route the power cord through the access hole and properly attach the power supply wires to the leads in the junction box.
2. Attach the remote condenser fan motor wires to the wires in the junction box tagged "fan motor leads".
3. Install field supplied strain reliefs per code. Attach a ground wire to the ground connection in the junction box.
4. Check voltage when complete.
5. Return the junction box cover to its original position and secure with the original screws.

Follow all applicable local, state and national codes.

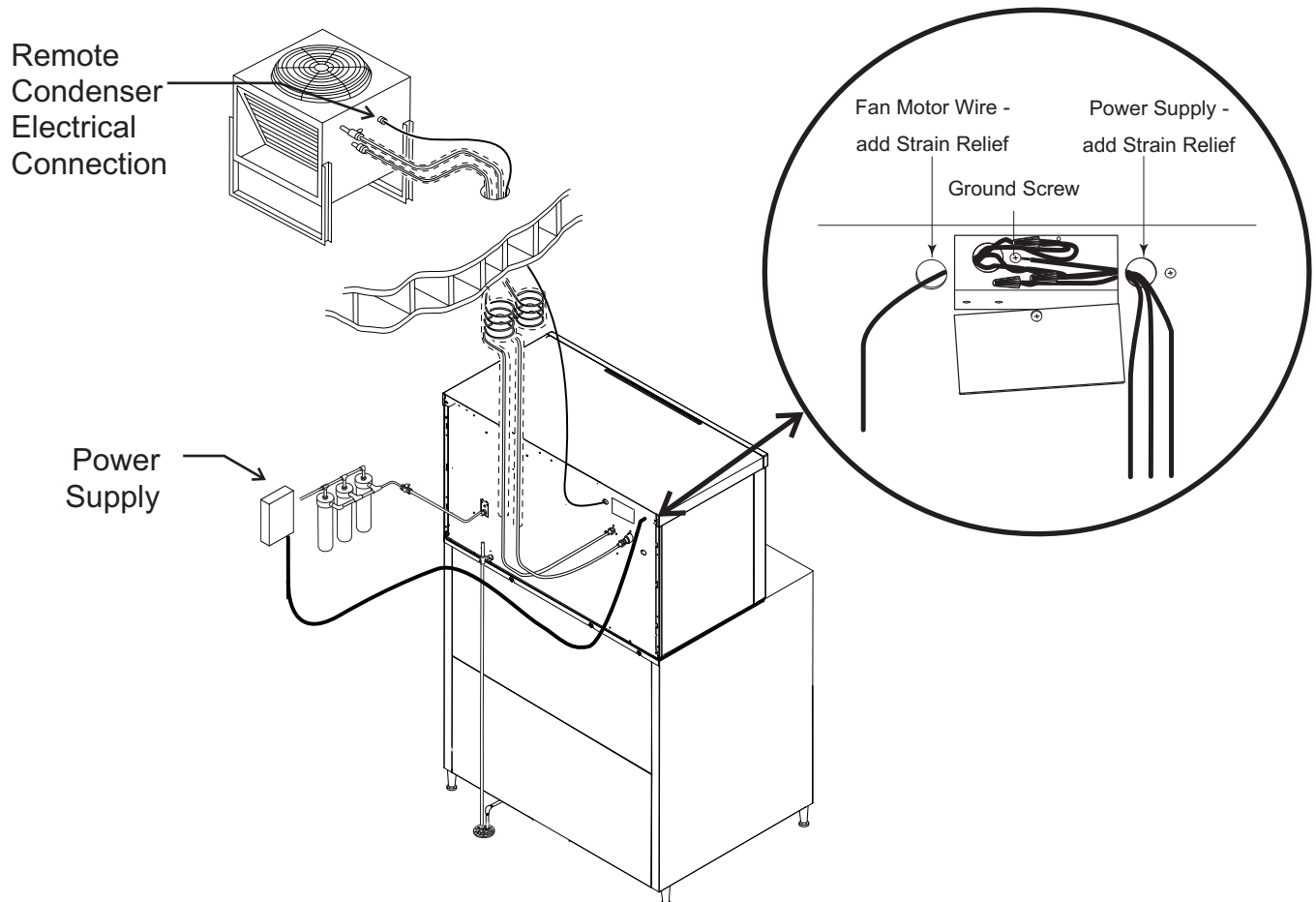

Electrical Connections

C2648 Service Manual - Installation

Final Check List:

1. Is the unit located indoors in a controlled environment?
2. Is the condenser located where it can receive adequate cooling air?
3. Has the correct electrical power been supplied to the machine?
4. Have all the water supply connections been made?
5. Have **all** the drain connections been made?
6. Has the remote condenser been properly installed?
7. Has the interconnecting tubing been properly routed between the remote condenser and the ice machine?
8. Have the quick connects been properly connected?
9. Has the power supply wire from the ice machine to the remote condenser been properly run and connected?
10. Has the unit been leveled?
11. Have all unpacking materials been removed?
12. Is the water pressure adequate?
13. Have the drain connections been checked for leaks?
14. Has the bin interior been wiped clean or sanitized?
15. Have any water filter cartridges been replaced?
16. Have all required kits and adapters been properly installed?

C2648 Service Manual - Installation

Initial Start Up

1. Remove front and left side panels. Check machine for any packing or wires rubbing moving parts. Note location of control board in upper left corner of the machine's front.
2. Switch on the electrical power to the machine. Observe that some of the control's indicator lights glow and its display shows *D*.
3. Wait 4 hours for the compressor's crankcase heater to warm up the oil in the compressor.

1. Open the water supply valve.
2. Turn the receiver's outlet valve to the full open position.
3. Push and release the ON button.

The indicator light will begin to blink *F*. The purge valve will open and the water pumps will start. The inlet water valve will open to add water to the reservoir. After a few seconds the purge valve will close and the water pumps will stop. Water will flow into the machine until the reservoir is full. The hot gas valves and harvest assist devices will activate and the liquid line solenoid valve will open, then the compressor, remote fan motor and water pumps will start. The display will show a continuous *F*. Five seconds later the hot gas valves will close and the harvest assist devices will return to their standby positions. Warm air will be discharged from the condenser coil.

4. During the Freeze cycle move each curtain to confirm the controller is getting the signal from the curtain switch. Two of them will cause the SW1 or SW2 light on the control board to blink ON when the curtain moves away from the evaporator and OFF. One of the curtains will cause the period in the display code to blink ON when the curtain is moved away and OFF when returned to its normal position. Note: Moving the curtain during the Freeze cycle has no affect on unit operation.
5. Observe the Ready for Harvest indicator light. It may blink early in the freeze cycle, that is normal. The control will ignore that signal for the first 6 minutes of freeze.

6. When the ice has frozen enough, the Ready for Harvest indicator light will be on steady. After it's been on steady for a few seconds Harvest will begin.

7. The display shows an *H*.

The hot gas valves open and the harvest assist mechanisms are activated. The purge valve opens to drain some water, when it does the inlet water valve opens to refill the reservoir. After a few seconds the purge valve closes but the inlet water valve continues to fill the reservoir. Harvest continues until the ice is released as a unit from each evaporator and forces each curtain to open. When all curtains have opened and re-closed the controller returns the unit to a freeze cycle.

8. Check the ice harvested for proper bridge thickness. The ice bridge is factory set at 3/16 inch. If needed, adjust bridge thickness. Do NOT make it too thin.
9. Determine the water purge setting from the table on the next page. If desired, change the setting to accommodate the local water conditions.
10. Return the panels to their normal positions and secure them to the machine.
11. Instruct the user in the operation of the machine and its maintenance requirements.
12. Fill out and mail the warranty registration form.

Typical Ice Making Cycle Times (minutes)

Listed times are for clean machines. Cycle times at startup will be longer until the system stabilizes.

| Model | 70°F. cond air / 50°F. water | 90°F. cond air / 70°F. water |
|--------|------------------------------------|------------------------------------|
| C2648R | 11 - 13 | 13 - 15 |

C2648 Service Manual - Installation

Adjustments

Bridge Thickness - For A Service Tech Only

1. Push and hold Off till the machine stops.
2. Remove evaporator cover.
3. Remove left most curtain.
4. Use a box wrench and rotate the bridge thickness adjustment screw in 1/8 turn increments CW to increase bridge thickness. Rotate CCW to decrease bridge thickness.

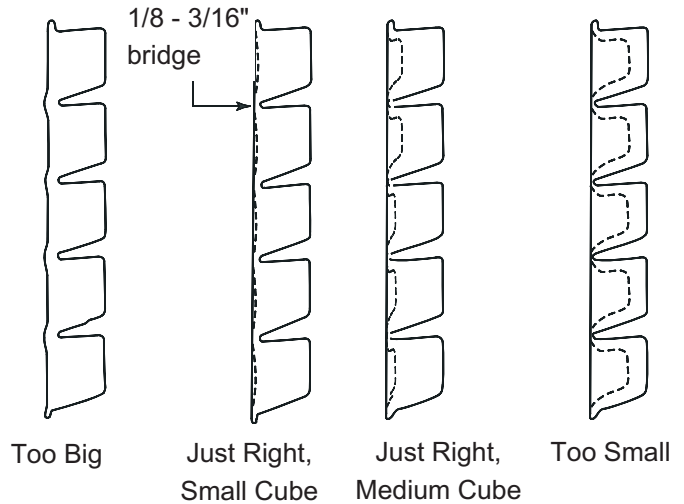

Caution: Do not make the bridge too thin or the machine will not harvest properly. Bridge thickness adjustments are not covered by warranty.

5. Return curtain to its normal position.
6. Push and release the On button. Check next harvest of ice. Repeat steps 1-6 if needed.

Water purge setting

The water purge is factory set to the automatic position, suitable for most water conditions. The setting can be changed to one of 5 manual settings or left on automatic.

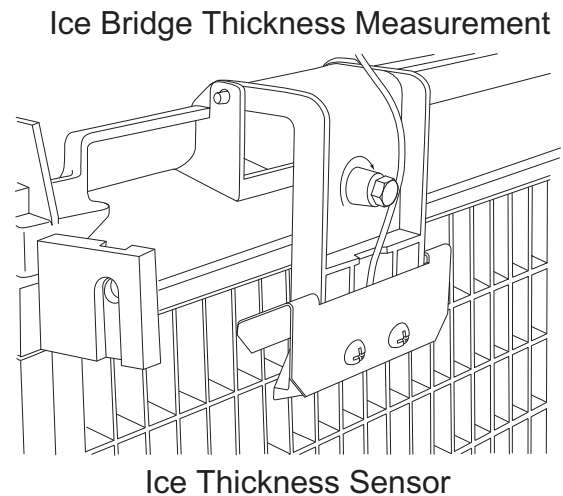

| purge setting | 1 - Minimum | 2 - Moderate | 3 - Standard | 4 - Heavy | 5 - Maximum | A - Automatic |
|---------------|------------------------|--------------|-----------------------------------|-----------|----------------|--|
| Water Type | RO water or equivalent | | Factory Setting for typical water | | High TDS water | Any with conductivity not less than 10 microSiemens/cm |

To set:

1. Switch the machine OFF by holding the Off button in until a number or the letter *A* shows on the display.
2. Press and release the On button repeatedly until the number on the display corresponds to the desired setting.
3. Press and release the Off switch again to return to the normal control state.

C2648 Service Manual - Installation

Use and Operation

Once started, the ice machine will automatically make ice until the bin is full of ice. When ice level drops, the ice machine will resume making ice. There are four indicator lights at the front of the machine that provide information on the condition of the machine.

External Indicator Lights:

- Power
- Status
- Water
- Clean

Indicator Lights & Their Meanings

| | Power | Status | Water | De-Scale & Sanitize |
|-----------------|---|---|---------------|-------------------------------|
| Steady Green | Normal | Normal – bin full or making ice | - | - |
| Blinking Green | Self Test Failure | Switching on or off | - | - |
| Blinking Red | - | Diagnostic shutdown or, if making ice, temperature sensor failure | Lack of water | - |
| Yellow | - | - | - | Time to de-scale and sanitize |
| Blinking Yellow | - | - | - | In Cleaning mode |
| Light off | No power | Switched off | Normal | Normal |
| All Blinking | Unit remotely locked out – check with leasing company | | | |

Other Indicators

If the Water light is on, the machine has sensed a lack of water. Check the water supply to the machine. The water may have been shut off or the water filter cartridges need to be changed.

If the Clean light is on, the machine has determined that it may need to be cleaned. Contact an authorized Scotsman service agent and have the machine cleaned, de-scaled and sanitized.

Removal of the front panel allows review of the Code Display and Component Indicator Lights.

Note: A Component Indicator Light switches ON to indicate that the component is operating.

Note: There are **three** Curtain Switch lights, **SW1**, **SW2** and the **Period** in the display code. A curtain switch light is ON when a curtain is either open or not present.

C2648 Service Manual - Installation

Switch Panel Area

There is standard front access to two switches – on and off.

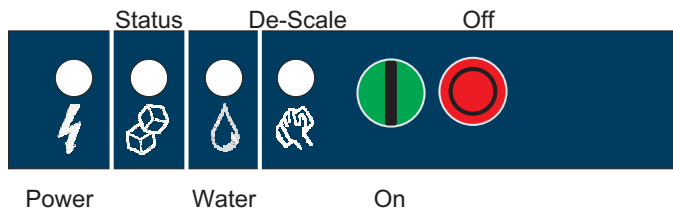

To switch the machine OFF, push and release the Off button. The machine will shut off at the end of the next cycle.

To switch the machine ON, push and release the On button. The machine will go through a start up process and then resume ice making.

Control Options

There are two optional, field installed controls that can be on this machine.

- KVS Adjustable ice level control
- KSBU Advanced Feature control

Adjustable ice level control (optional)

When this option is present there is an adjustment knob and an additional indicator light to the right of the four standard indicator lights. The ultrasonic ice level control allows control of the point that the ice machine stops making ice. Reasons for this include:

- Seasonal changes in ice used
- Planning to sanitize the bin
- Faster turnover for fresher ice

Use of adjustable ice level control

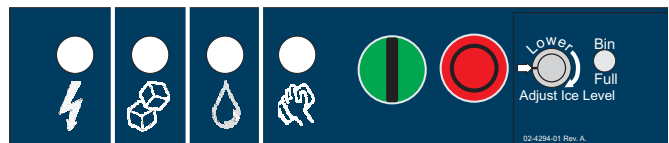

Vari-Smart Control Area

There are several positions the ice level can be set to, including Off (knob and label indicators lined up), where it fills the bin until the standard bin control shuts the machine off. See the kit's instructions for complete details.

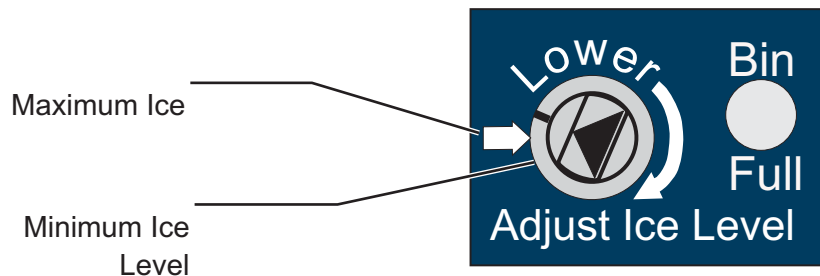

Rotate the adjustment post to the desired ice level. The machine will fill up to that level and when it shuts off the Bin Full indicator light next to the adjustment knob will be On.

Note: Ice will build up in the bin at an angle, the distances controlled will be from the sensor to the top of the ice directly beneath it.

The actual distance between the highest point of the ice may be closer or further away, depending upon the angle of the ice.

C2648 Service Manual - Installation

Options and Other Information

Smart-Board

When this option is present there is an additional display panel in the area below the main control board. It is not visible when the front panel is on. The Smart-Board's features include:

- Seven day programmable ice level setting when used with the optional Vari-Smart ice level control
- Recording of machine operation, including cycle time.
- Calculation of average cycle time
- Recall of malfunctions with the time they occurred.

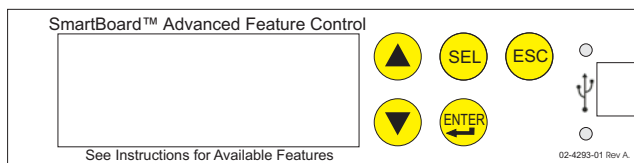

Ice

The cuber drops ice in large sections. That ice will break up into random parts as it falls into the bin, but some large sections may remain on top of the ice in the bin. When removing ice, tap the groups of ice with an ice scoop to separate them into smaller units.

Heat

Most heat is exhausted at the remote condenser. The ice machine head should not generate significant heat.

Noise

The ice machine will make noise when it is in ice making mode. The compressor and water pumps all produce some sound. It is also normal to hear some cracking just before the harvest cycle begins. In addition, during the harvest cycle each harvest assist solenoid will click twice as it pushes the ice out and returns to its normal position. The ice harvests as a unit or slab, which makes some noise when it impacts the bin. These noises are all normal for this machine.

Caution: Do not place anything on top of the ice machine, including the ice scoop. Debris and moisture from objects on top of the machine can work their way into the cabinet and cause serious damage. Damage caused by foreign material is not covered by warranty.

C2648 Service Manual - Installation

Cleaning, Sanitation and Maintenance

This ice system requires three types of maintenance:

Remove the build up of mineral scale from the ice machine's water system and sensors.

Sanitize the ice machine's water system and the ice storage bin.

Clean the remote condenser.

It is the User's responsibility to keep the ice machine and ice storage bin in a sanitary condition. Without human intervention, sanitation will not be maintained. Ice machines also require occasional cleaning of their water systems with a specifically designed chemical. This chemical dissolves mineral build up that forms during the ice making process.

Sanitize the ice storage bin as frequently as local health codes require, and every time the ice machine is cleaned and sanitized.

The ice machine's water system should be cleaned and sanitized a minimum of twice per year.

1. Remove front panel.
2. Push and release the blue Harvest button. Machine will go thru a manual harvest of 3 minutes then shut off.
3. Remove all ice from the bin.
4. Push and release the yellow Clean button.
5. Wait until the Purge Valve light goes out, then pour 24 ounces of Scotsman Clear 1 Scale remover into the water reservoir.
6. Operate the machine for at least 10 minutes.
7. Push and release the yellow Clean button again.
8. Operate the machine for at least 20 minutes, then push the red Off button.
9. Check for scale, repeat steps 3 thru 7 if scale is still evident.
10. Disconnect pump hoses from water distributors.
11. Depress snaps and pull water distributors forward and out of the machine. Remove covers and inspect for scale. Remove any remaining scale. Set aside.
12. Remove evaporator covers, set aside.
13. Remove right side panel and liner, set aside.
14. Remove all three curtains. Set aside.
15. Twist counterclockwise and lift water pumps up and tip to one side.
16. Remove front water reservoir cover plate, set aside.
17. Remove sump cover and water level sensor, set sump cover aside.
18. Pull water reservoir forward; tip up and out of the machine.
19. Mix a locally approved sanitizer solution. If approved, mix one ounce of liquid household

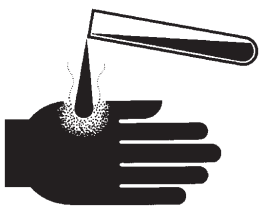
| | |
|---|---|
|  | <p>CAUTION</p> <p>Ice machine cleaner contains acids. Acids can cause burns.</p> <p>If concentrated cleaner comes in contact with skin, purge with water. If swallowed, do NOT induce vomiting. Give large amounts of water or milk. Call Physician immediately. Keep out of the reach of children.</p> |
|---|---|

C2648 Service Manual - Installation

bleach to two gallons of lukewarm (95-100 degrees F.) water.

20. Thoroughly wash the water reservoir cover plate, sump cover, water distributors, distributor covers, evaporator covers, right side panel liner, curtains and reservoir with the sanitizer solution.
21. Thoroughly wash the shelf of the ice machine cabinet where the reservoir was resting.
22. Thoroughly wash the interior of the evaporator compartments including the back panels and evaporator edges.
23. Return the reservoir to its original position
24. Return the sump cover, water level sensor, water distributors with covers, pump hoses, evaporator covers, right side panel liner and curtains to their original positions on the ice machine.
25. Return the pumps to their normal positions.
26. Pour one gallon of the sanitizer solution into the reservoir.
27. Push and release the yellow Clean button.
28. Operate the machine for about a minute.
29. Push and release the yellow Clean button again.
30. Operate the machine for 20 minutes then push the red Off button.
31. Return all removed panels to their original positions.
32. Push and release the green ON button to resume ice making. Remove and discard all ice.

Clean Storage Bin

Mix a solution of Scotsman Nickel Safe ice machine cleaner and wash all interior surfaces of the ice storage bin to remove any mineral scale build up. Pour excess cleaner solution into the bin's drain.

Squeeze Tabs Together, Slide Out Until it Stops,

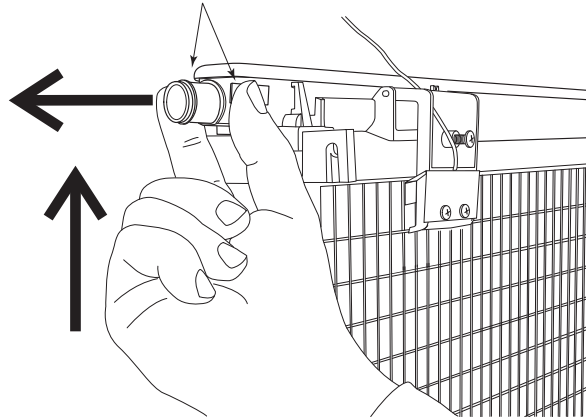

Remove Water Distributor

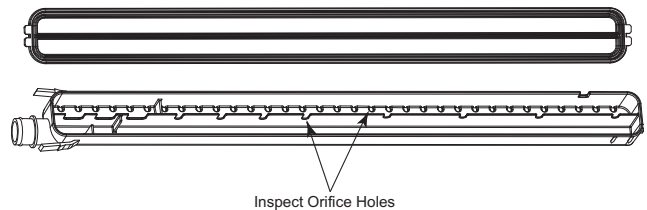

Inspect Water Distributor

Mix a solution of sanitizer and thoroughly wash all interior surfaces of the ice storage bin. Pour excess sanitizer solution into the bin's drain.

C2648 Service Manual - Installation

Remote condenser and other maintenance

The condenser fins will need to be cleaned.

Push and release the Off button. Wait until the machine stops.

Note: Lock out the controller or the ice machine power supply to prevent an unauthorized fan motor restart.

If there is imbedded grease, use a commercial coil cleaner to wash out the grease. Dust can be blown out with compressed air from the inside or use a vacuum cleaner and soft brush. Be careful not to damage the condenser's fins. Use a fin comb to straighten any bent fins.

Exterior Panels

The front and side panels are durable stainless steel. Fingerprints, dust and grease will require cleaning with a good quality stainless steel cleaner.

Water filters

If the machine has been connected to water filters, check the cartridges for the date they were replaced or for the pressure on the gauge. Change cartridges if they've been installed more than 6 months or if the pressure drops too much when the ice machine fills with water.

C2648 Service Manual

Service Table of Contents

| | | | |
|---|---------|---|---------|
| Overall System Types | page 2 | Test Procedures - Loads | page 31 |
| Controller Information. | page 3 | Test Procedures - Loads | page 32 |
| Controller Information. | page 4 | Test Procedures - Loads | page 33 |
| How It Works | page 5 | Test Procedures - Loads | page 34 |
| Electrical Sequence - Remote Cooled | page 6 | Reservoir Removal | page 35 |
| Electrical Component Details. | page 8 | Controller Differences | page 36 |
| Electrical Component Details. | page 9 | Thermistor Values | page 37 |
| Electrical Component Details. | page 10 | Performance Information | page 39 |
| Refrigeration | page 11 | Repair Procedures | page 40 |
| Refrigeration Schematic | page 12 | Harvest Assist Solenoid | page 41 |
| Water System. | page 13 | Repair Procedures | page 42 |
| Control Operation. | page 14 | Repair Procedures | page 43 |
| Control Safeties. | page 15 | Repair Procedures | page 44 |
| Restarts. | page 16 | Repair Procedures | page 45 |
| Control Button Use (from standby) | page 17 | Repair Procedures | page 46 |
| Control Button Use - continued. | page 18 | Repair Procedures | page 47 |
| Diagnostics - Remote Air Cooled. | page 19 | Refrigeration Removal and Replacement Procedures | page 48 |
| Diagnostics - Remote Air Cooled. | page 20 | Refrigeration Removal and Replacement Procedures | page 49 |
| Diagnostics - Remote Air Cooled. | page 21 | Refrigeration Removal and Replacement Procedures | page 50 |
| Low Ice Making Capacity | page 22 | Refrigeration Removal and Replacement Procedures | page 51 |
| Test Procedures - Sensors | page 23 | Refrigeration Removal and Replacement Procedures | page 52 |
| Ice Thickness Sensor. | page 24 | Vari-Smart™ Adjustable ice level option | page 53 |
| Water Level Sensor. | page 25 | Adjustable Ice Level System Information and Diagnosis | page 54 |
| Temperature Sensors | page 26 | Prodigy's Smart-Board™ - an Advanced Feature Control | page 55 |
| Test Procedures - Loads | page 27 | | |
| Test Procedures - Loads | page 28 | | |
| Test Procedures - Loads | page 29 | | |
| Test Procedures - Loads | page 30 | | |

C2648 Service Manual

Overall System Types:

- **Refrigeration:** Mechanical remote cooled. Includes reciprocating hermetic compressor, head pressure control valve (headmaster), receiver and liquid line solenoid valve.
- **Water System:** Inlet water solenoid valve fills reservoir once per cycle. Purge solenoid valve opens to discharge some reservoir water once per cycle.
- **Control System:** Electronic
- **Harvest cycle sensor:** Conductivity probe
- **Water full/empty sensor:** Conductivity probe
- **Bin Control:** Curtain Switches
- **Ice type:** Unified
- **Harvest system:** Hot gas defrost with mechanical assist

Electrical Components:

- Compressor
- Liquid line valve
- Contactor
- Water Pumps (2)
- Pump relay - NC - shuts pump 2 off during draining
- Inlet Water Solenoid Valve
- Purge or Dump Valve
- Fan Motor - on remote condenser
- High pressure cut out
- Harvest Assist Solenoids (3)
- Hot Gas Valves (3)
- High capacity relay - operates all 3 harvest assist solenoids and hot gas valves
- Controller
- Transformer – 12v AC for the controller only
- Water Level Sensor
- Ice Thickness Sensor
- Curtain Switches (3)

C2648 Service Manual

Controller Information

Machine Indicator Lights

- Power
- Status
- Water
- Clean

Code Display

Main codes - automatically displayed

| | |
|------------------|-------------------------------|
| <i>F</i> | Freeze Cycle |
| <i>F</i> flashes | Freeze Cycle is Pending |
| <i>H</i> | Harvest Cycle |
| <i>H</i> flashes | Manual Harvest |
| <i>b</i> | Bin is Full |
| <i>C</i> | Clean Cycle |
| <i>L</i> | Board Locked |
| <i>d</i> | Test Mode |
| <i>0</i> | Off |
| <i>E</i> | Self Test Failed |
| <i>1</i> flashes | Max Freeze - Retrying |
| <i>1</i> | Max Freeze Time Shut Down |
| <i>2</i> flashes | Max Harvest - Retrying |
| <i>2</i> | Max Harvest Time Shut Down |
| <i>3</i> | Slow Water Fill |
| <i>4</i> | High Discharge Temp |
| <i>5</i> | Sump Temp Sensor Failure |
| <i>7</i> | Discharge Temp Sensor Failure |
| <i>8</i> flashes | Short Freeze - Retrying |
| <i>8</i> | Short Freeze - Thin ice |

Setting Codes - requires push button sequence

Water Purge Settings

R, 1, 2, 3, 4, 5

De-Scale notification

- see table to the right

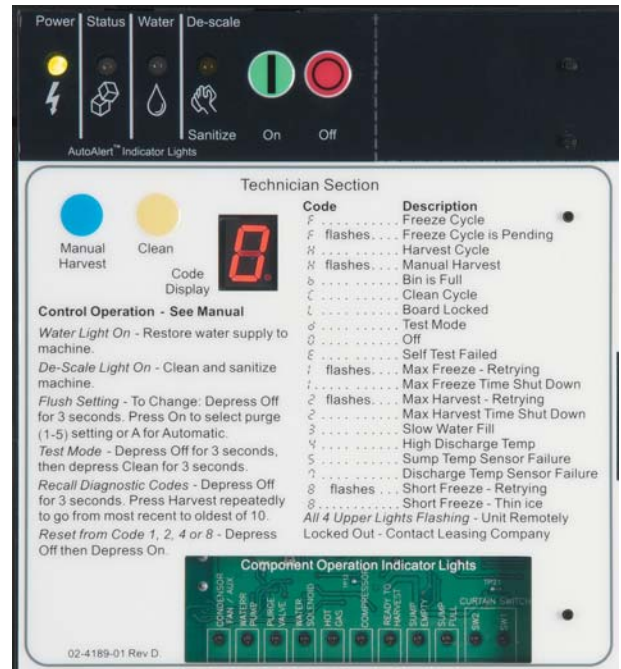

Change De-Scale Notification Interval - This feature is accessible only from standby (Status Light Off).

1. Press and hold harvest button for 3 seconds.

This starts the Time to Clean Adjustment Mode and displays the current time to clean setting.

2. Press the clean button repeatedly to cycle through the 4 settings:

| |
|--------------------|
| 1 year |
| 0 or disabled |
| 4 months |
| 6 months (default) |

3. Push Off to confirm the selection.

C2648 Service Manual

Controller Information

Component Indicator Lights

- Condenser Fan / Aux (Aux = liquid line solenoid)
- Water Pump
- Purge Valve
- Water Solenoid
- Hot Gas
- Compressor
- Ready to Harvest
- Sump Empty
- Sump Full
- Curtain SW1
- Curtain SW2
- Curtain SW3 - in Display Code

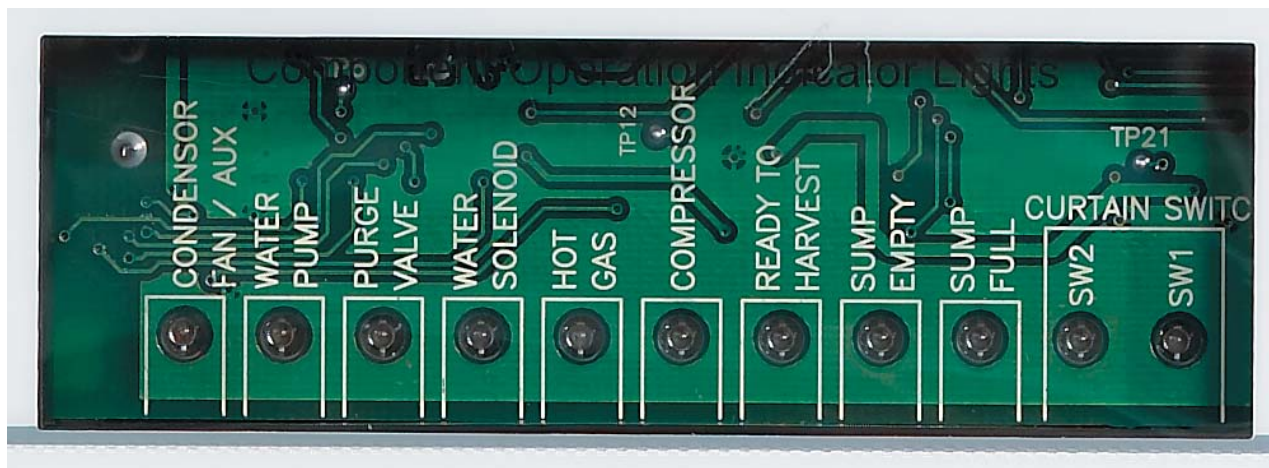
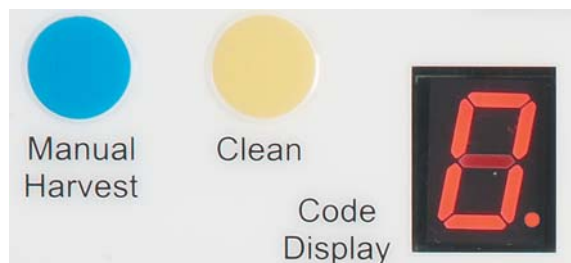

Component Indicator Lights

C2648 Service Manual

How It Works

Freeze Cycle. At start up the controller drains and refills the reservoir. The reservoir refills when the mid length water level sensor probe is uncovered and continues to fill until the top probe is in contact with water. When the reservoir has filled, the liquid line valve, compressor and water pumps are switched on. After the discharge pressure has increased past the set point of the headmaster in the condenser, the headmaster will direct refrigerant gas into the condenser and warm air will be discharged out of the condenser. The headmaster will modulate to maintain a minimum discharge pressure. Water flows over the evaporators as the refrigeration system begins to remove heat. When the water temperature falls to a preset point, as measured by the water temperature sensor, the controller shuts off the water pumps for 30 seconds. The freeze cycle resumes when the pumps restart and ice begins to form on the evaporator. As it forms, the water flowing over the ice moves closer and closer to the metal tip of the ice thickness sensor. When it comes into contact with the sensor for a few continuous seconds, that signals the controller that the freeze cycle is complete.

Harvest Cycle. When the harvest cycle begins, the controller connects power to the High Capacity Relay, which switches on the hot gas valves, and through a parallel circuit, the harvest assist solenoids. After a few seconds the purge valve opens. When the purge valve is opened, a relay is energized to disconnect power to pump number 2, and water is drained from the reservoir by pump number 1. Based on either the automatic purge or manual purge setting, the pump and purge valve will be switched off at a time determined to have drained enough water for that setting. The inlet water valve will open to fill the reservoir anytime the mid length probe is uncovered, which occurs during the reservoir drain cycle. Harvest continues as the hot discharge gas flows into the evaporator's serpentine, heating up the evaporators. At the same time the harvest assist solenoids are pushing against the back of each ice slab. When the ice releases from an evaporator, it harvests as a unit, and the harvest assist probe provides some additional force to push it off. When the ice falls off it will force that curtain open. An open curtain during the harvest cycle signals the controller that that evaporator has released its ice. The controller will continue harvest until all three curtains have opened. If a curtain remains open, the controller will shut the machine down. Anytime harvest is complete the hot gas valve and harvest assist solenoid are shut off. The harvest assist solenoid pin returns to its normal position by spring pressure.

If the curtains re-close after harvest, the freeze cycle will restart.

Shut down occurs when a curtain remains open after a harvest cycle. The controller will switch off the liquid line solenoid valve and operate the compressor for 30 seconds, then shut it off.

C2648 Service Manual

Electrical Sequence - Remote Cooled

Power connected, unit previously switched Off.

Control board does a self check. If the self check fails, the unit displays an E and no further action will occur.

If the self check passes, the controller will display a 0, the curtain lights will be ON and the Power and Sump Empty lights will be ON.

Pushing and releasing the On button will start the ice making process.

The display will begin to blink F. The component indicator lights will switch on and off to match the following process:

The purge valve opens and one water pump starts to empty the reservoir. This is done to discharge any excess water from ice melting into the reservoir.

The hot gas valves and the harvest assist solenoids are energized by the High Capacity Relay.

The inlet water valve will open to fill the reservoir. The water valve can open any time the water level is low.

After a few seconds the purge valve closes and the pump shuts off.

When the reservoir is full the inlet water valve stops, the liquid line valve is opened and the compressor switches on. Five seconds after the compressor starts the hot gas valve and the harvest assist solenoid are de-energized. Both water pumps switch on.

Light Information: The display shows a non-blinking F. The Power and Status Lights will be Green. The compressor, fan motor, water pump, sump full lights will be ON and all curtain switch lights will be OFF.

The Freeze cycle continues. When the reservoir water temperature falls to a certain preset point, the water pumps will shut off for 30 seconds. This is the anti-slush period. At this time the controller checks the conductivity of the water in the reservoir for the auto-purge feature. After the water pumps restart the Sump Full light will go out and neither sump lights will be on for the rest of the freeze cycle.

When the ice has built up enough so that the water flowing over the evaporator comes into continuous contact with the ice level sensor, the Ready to Harvest light will begin to blink on and off. When it has been On continuously for 3 seconds, the controller will switch the machine into a Harvest cycle.

Indicator Information: The display shows a non-blinking H. The Power and Status Lights will be Green. The compressor and hot gas valve lights will be ON. After a few seconds the water pump, purge valve and inlet water valve lights will switch on.

The three harvest assist solenoids are connected in parallel with the three hot gas valves. Although energized throughout the harvest cycle, a harvest assist piston does not move until the ice has become partially loosened from the evaporator plate by the action of the hot refrigerant gas passing through the evaporator serpentine.

C2648 Service Manual

The remote condenser fan motor is powered by the compressor contactor, so it will be operating during the harvest cycle.

The operating water pump and purge valve will shut off when the purge level setting time has been reached, either the manual time or the automatic time. The inlet water valve will remain on until it fills the reservoir. The Ready to Harvest light will switch Off when the ice falls from the evaporator.

Harvest continues until the ice slab is ejected from the evaporator and falls, opening the curtain. When the curtain opens, the magnetic reed curtain switch opens, breaking the circuit to the controller. If all the curtains re-close within 30 seconds, the controller switches the machine back into another freeze cycle. If any curtain switch remains open, the controller shuts the machine down and puts it into a standby position.

C2648 Service Manual

Electrical Component Details

Compressor

- Operated by the compressor contactor.

Contactors

- Operated by the controller and the high pressure cut out switch. Line voltage coil. When energized the Compressor indicator light will be ON.

Water Pumps

- Operated by the controller, one of them thru a NC relay. When the Pump light is ON during a Freeze cycle, both pumps should be operating. When the Pump and Purge lights are both ON, one pump will be ON and one will be OFF.

Inlet Water Solenoid Valve

- Operated by the controller. Line voltage coil. When energized, the Water Solenoid indicator light will be ON.

Purge Valve

- Operated by the controller. Line voltage coil. When energized, the Purge Valve indicator light will be ON. Energized for a time during harvest.

Fan Motor

- Remote condenser fan motor is on whenever the compressor is.

High pressure cut out

- There is a high pressure cut out switch that shuts the power off to the compressor contactor if the discharge pressure is too high. It is an automatic reset.

Harvest Assist Solenoids

- Operated by the controller through a relay. In parallel with the hot gas valve. Cycles on and off at the beginning of a restart. Energized throughout the harvest cycle. Line voltage coil.

Liquid Line Valve

- Opened by the controller to start a freeze cycle. Closed to shut unit off. Line voltage coil.

Hot Gas Valves

- Operated by the controller through a relay. In parallel with the harvest assist solenoid. Cycles on and off at the beginning of a restart. Energized throughout the harvest cycle. Line voltage coil.

C2648 Service Manual

Electrical Component Details

Controller

- Senses ice thickness, water level, water temperature, discharge temperature. Controls compressor contactor, fan motor, water pump, inlet water valve, hot gas valve, purge valve, harvest assist solenoid. Indicates status and component operation. 12 volt.

Transformer

- 12 volt secondary, supplies power to controller only.

Water Level Sensor

- Three probe conductivity sensor. Longest probe is common, mid probe is refill sump, top probe is full sump. Refill can occur at any time.

Ice Thickness Sensor

- Single wire conductivity sensor. Circuit made from controller to ground to controller when water contacts a probe suspended over ice plate. Signals ready for harvest.

Curtain Switches

- Magnetic reed switch. Normally open, switch is closed when magnet is nearby. This model has three curtain switches. Curtains may be removed in the freeze cycle without affecting controller operation. A curtain removed during harvest will cause the controller to terminate harvest and shut the unit off. All curtains must open to terminate harvest, and if any one remains open for 30 seconds that signals the controller to shut the unit off on bin full.

Water temperature sensor

- Thermistor inserted into the water pump discharge hose. Reported temperature used by the controller to determine anti-slush cycle start time.

C2648 Service Manual

Electrical Component Details

Discharge temperature sensor.

- Thermistor attached to the discharge line near the compressor. Reported temperature used by the controller to determine end-of-cycle-fan-off-delay time. If discharge temperature exceeds a preset maximum, controller will shut the machine off.

Note: Controller will operate machine in a default mode with thermistors disconnected from the controller. Diagnostic code #5 or 7 will be displayed during that time.

Component Indicator Light Table

| System | Indicator Light ON |
|------------------------------------|---|
| Condenser Fan or Liquid Line Valve | LLV open |
| Water Pump | Pump Motor Powered |
| Purge Valve | Purge Valve Opens |
| Inlet Water Solenoid Valve | Inlet Water Valve Opens |
| Hot Gas | Hot Gas Valve Opens |
| Compressor Contactor | Contactors Closes |
| Ready to Harvest | Water contacting ice thickness sensor probe |
| Sump Empty | Open between mid sensor and common |
| Sump Full | Closed between top probe and mid probe |
| Curtain Switch | Curtain open |

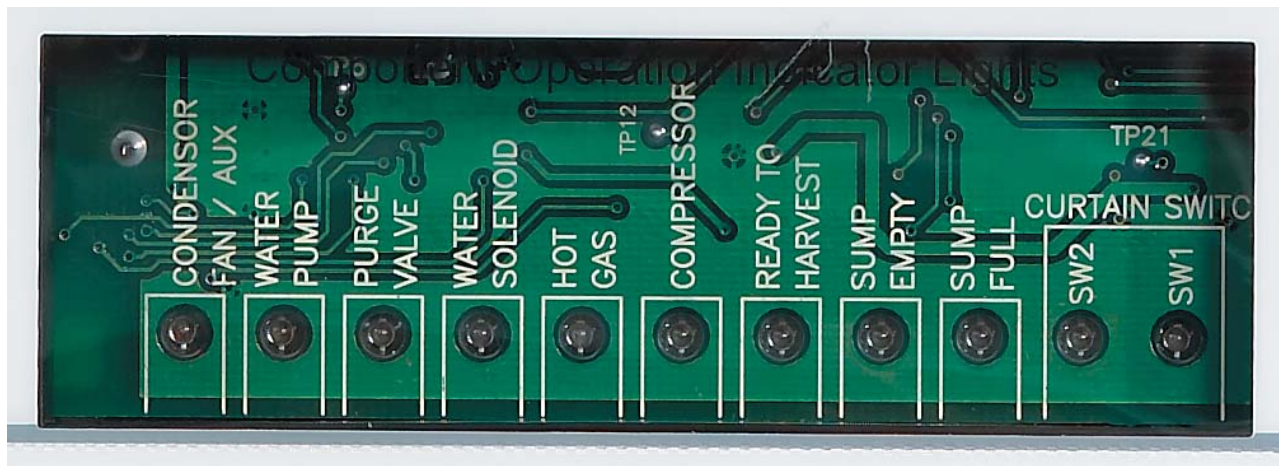

Component Indicator Lights

C2648 Service Manual

Refrigeration

Refrigerant: R-404A

Charge: 240 ounces

Compressor: Copeland hermetic

Compressor Amps:

- Freeze - 13.2 to 12.9, declining to 9.6 at the end of the freeze cycle. 11.6 to 11.9 at five minutes.
- Harvest - 12.7 to 11.8

Expansion valves: Non adjustable, internally equalized, one per evaporator.

Hot gas valves: Pilot operated, line voltage coils. One per plate.

Condenser: Upflow type with aluminum coils.

Headmaster: Included with condenser.

Remote Systems: Head pressure control valves in condenser. No check valves. Controller pumps unit down by closing the liquid line valve and keeping the compressor on for a fixed time period at shut down.

High pressure cut out. Shuts compressor off if discharge pressure is too high, automatic reset.

- Cut out at 450 PSIG,
- Cut in at 350 PSIG.

Evaporators: Unified cell plate. Nickel plated copper. 18" tall.

Small cube = half dice, medium cube = full dice.

- Small cube: 7/8" high x 7/8" deep x 3/8" high
- Medium cube: 7/8" high x 7/8" deep x 7/8" high

C2648 Service Manual

Refrigeration Schematic

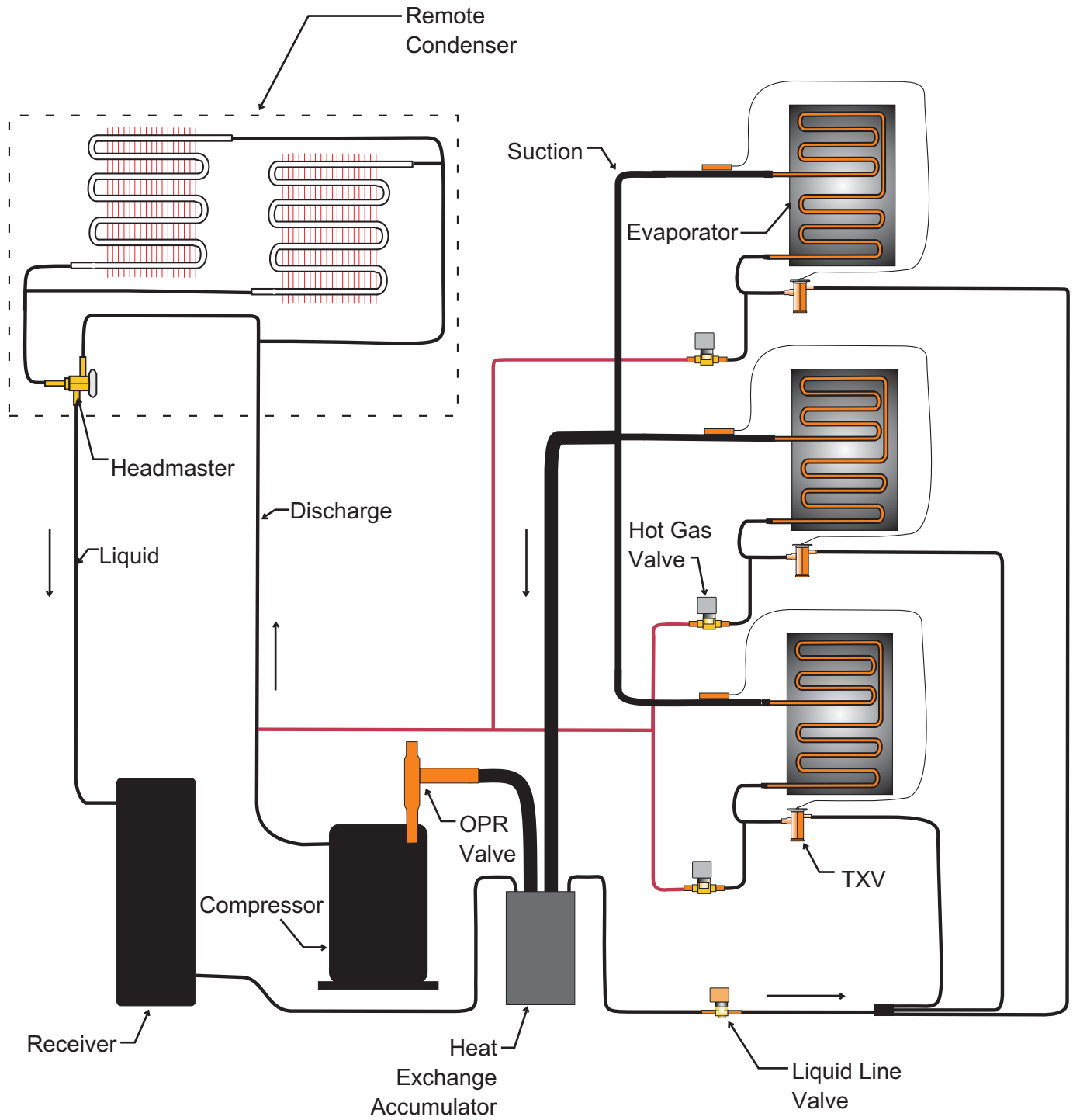

C2648R

C2648 Service Manual

Water System

Batch type. Water reservoir contains full water charge for each ice making cycle.

Water valve: Solenoid type. Opens to fill reservoir when mid sensor probe no longer makes a circuit to the bottom probe. Closes when reservoir is full and top probe makes circuit to mid probe.

Pumps: Unsealed pedestal type, twist-release mounting

Water purge valve: Solenoid type. Opens to purge water during harvest cycle.

Water Level Sensor: Three probe conductivity.

Distributors: ABS plastic. Evenly distributes water over the evaporator surface. Slides off the evaporator top. Removable cover for ease of cleaning.



Water Distributor Removal

C2648 Service Manual

Control Operation

Standard control:

- Electronic controller operating from a 12 AC volt power supply. Will operate within a voltage range between 10 and 15.5.
- User's Indicator lights, four front visible: Power, Status, Water, De-scale/Sanitize.
- Accessible On switch.
- Accessible Off switch.
- Code Display: Displays letters and numbers to indicate cycles and diagnostic codes.
- Manual Harvest switch: Use to trigger harvest at any time.
- Clean switch: Use to initiate and finish the de-scale or sanitizing cycles.
- Component Operation Indicator Lights: Indicate the status of certain components; water level; ready for harvest; curtain switch position.
- Power Light: On when power is being supplied to the controller.
- Status Light: Green when machine is in ice making mode and is operating correctly. Blinks red when a machine malfunction has been detected.
- Water Light: Blinks red when reservoir does not fill with allowed time period.
- De-scale / sanitize: Yellow when the controller has determined it is time to de-scale and sanitize the machine. Use clean process to reset light. Time is determined by power up time and controller's setting. Standard setting is 6 months.

Controller Connections:

- J1 – Ground and Power Supply
- J2 – High voltage power harness to loads
- J3 – Factory use
- J4 – Optional board connector
- J5 - Communications port
- J6 – Thermistor connection
- J7 – Curtain switch
- J8 – Curtain switch
- J9 – Water level sensor
- J10 – Ice thickness sensor
- J11 – Bin thermostat. Used for Curtain Switch 3. This model cannot use with a bin thermostat.

C2648 Service Manual

Control Safeties

Max freeze time – 45 minutes

When exceeded, the controller will attempt another freeze cycle. If the next cycle's freeze time is less than maximum, the control will continue normal ice making. If the next freeze cycle was too long, the control will again attempt another freeze cycle. If the freeze cycle is too long three consecutive cycles, the controller will shut the unit off and it must be manually reset.

Min freeze time – 6 minutes

If the controller switches the machine into harvest within 20 seconds of the minimum freeze time, the controller will harvest for a preset time and does not stop if the curtain switch opens. If this occurs again in the next three cycles, the machine will shut down and must be manually reset.

Max harvest time – 3.5 minutes

If the harvest cycle has continued for 3.5 minutes without the curtain opening, the controller will shut the machine off for 50 minutes and then restart. If there is another the machine will shut the machine off for another 50 minutes and then restart. If it fails a third consecutive time the controller will shut the machine down and must be manually reset.

- Time between resets – 50 minutes
- Number of automatic resets – 2
- Max water fill time – 8 minutes. Machine will attempt a restart every 20 minutes.
- Max discharge temp – 250 degrees F.
- Time interval between cleanings – 6 months power on time - adjustable see page 18.
- Manual harvest time – 3 minutes
- Pump down interval. 12 hours. Pump down is 30 seconds of compressor only on time.
- Minimum compressor off time – 4 minutes
- Continuous Run Time Maximum Cycles - 100

C2648 Service Manual

Restarts

Power Interruption

The controller will automatically restart the ice machine after adequate voltage has been restored.

- *H* blinks on code display
- Status indicator light blinks
- Reservoir is drained and refilled

Default harvest is initiated. The curtain switch does not have to open to terminate harvest, harvest will continue until the default harvest time expires. Default harvest time is 3 minutes. The machine will then return to a normal freeze cycle.

Water Interruption

- The controller will attempt to fill the reservoir every twenty minutes until it is successful.

On-Off Switch Access

All models ship with the On and Off switches front accessible. If desired, the On and Off switches can be covered by changing the bezel in the front panel's trim strip. A cover-up bezel ships loose with the machine.

C2648 Service Manual

Control Button Use (from standby)

Set purge level, 1-5 (1 is minimum, 5 is maximum) or Automatic:

- Hold off button in for 3 seconds. Release.
- Press and release the On button to cycle through and select one of the five purge settings or to use the Automatic setting.

Recall diagnostic code:

- Hold off button in for 3 seconds. Release.
- Press and release the Harvest button to cycle through each of the last 10 error codes from most recent to oldest.

Clear diagnostic code:

- Hold Clean and Harvest buttons in for 3 seconds to clear all prior codes.

Reset control:

- Depress and release Off, then depress and release On

Start Test Mode:

- Hold Off button in for 3 seconds. Release.
- Hold Clean button in for 3 seconds. Release.

Lock / Unlock control:

- Hold On button in for 3 seconds, keep holding then press and release Off twice.

Empty reservoir:

- Hold Clean button in for 3 seconds. Release. Pump and purge valve will be ON for 30 seconds. Repeat as needed.

Test Mode:

- Depress Off for 3 seconds, release. Then depress Clean for 3 seconds.

The sump will fill the first 30 seconds of the test. If the sump is full it will overflow into the bin. At 30 seconds the WIV will shut off and the WP will turn on. You will be able to see and hear the water running over the plates. After 10 seconds the PV and HGV will turn on. Water will be purging from the machine. After 10 more seconds the compressor will start. 5 seconds later the HGV will close. The compressor will run for a total of 20 seconds. After which everything will turn off for 5 seconds. After that time the HGV will open and you'll be able to hear the hissing as the pressure is equalized. After 10 seconds all will be off and the output test will be complete.

C2448 Service Manual

Control Button Use - continued

Change De-Scale Notification Interval

Like the others, this feature is accessible only from standby (Status Light Off).

1. Press and hold harvest button for 3 seconds.

Starts the Time to Clean Adjustment State and displays the current time to clean setting.

2. Press the clean button repeatedly to cycle through the 4 possible settings:

- 1 year (8760 hours)
- 0 (disabled)
- 4 months (2920 hrs)
- 6 months (4380 hours) (default)

3. Press Off or leave untouched for 60 seconds to select the displayed interval

C2648 Service Manual

Diagnostics - Remote Air Cooled

| Problem | Likely Cause | Probable Solution |
|-----------------------------------|--|--|
| No power to unit | Power disconnected | Check breaker or fuse. Reset or replace, restart and check |
| No power to controller | Transformer open | Replace transformer |
| Shut down on max. water fill time | Water shut off | Restore water supply |
| Shut down on maximum freeze time | Water leak | Check purge valve, curtain, sump, pump hose |
| | Dirty condenser | Clean condenser |
| | Restricted location, intake air too hot | Have condenser moved |
| | Ice thickness sensor dirty or disconnected | Check ice thickness sensor probe |
| | Water distributor dirty | Remove and clean water distributor |
| | Inlet water valve leaks through during freeze | Check inlet water valve |
| | Connected to hot water | Check for bleed thru from / missing check valve in building water supply |
| | Incomplete harvest | Check harvest system |
| | High pressure cut out opened | Check fan motor |
| | | Check quick connects for complete piercing |
| | Fan motor not turning | Check fan motor, check fan blade |
| | Water pump not pumping | Check pump motor, check controller using test mode |
| | Pump hose disconnected | Check hose |
| | Liquid line valve does not open | Check coil of valve, check controller using test mode. |
| Compressor not operating | Check compressor contactor, check controller using test mode | |

C2648 Service Manual

Diagnostics - Remote Air Cooled

| Problem | Likely Cause | Probable Solution |
|--|---|---|
| Shut Down on Maximum Freeze Time (continued) | Compressor not operating (continued) | Check compressor temperature |
| | | Check compressor voltage |
| | | Check compressor windings |
| | Low refrigerant charge | Add some refrigerant and restart unit. If cycle time improves, look for leak. |
| | Hot gas valve leaks through during freeze | Check hot gas valve for hot outlet during freeze |
| | Thermostatic expansion valve bulb loose | Check bulb |
| | Thermostatic expansion valve producing very low or very high superheat | Check evaporator superheat, change TXV if incorrect |
| | Compressor inefficient | Check compressor amp draw, if low and all else is correct, change compressor |
| Shut down on maximum harvest time | Debris in refrigeration system | Recover charge. Open quick connects, check for loose or missing foil. Open liquid line and hot gas valves. Check for debris. Replace drier, evacuate and weigh in nameplate charge. |
| | Ice bridge thickness too small, not enough ice to open curtain | Check and adjust if needed |
| | Ice bridge thickness too large, ice frozen to evaporator frame | Check and adjust if needed |
| | Purge valve does not open, water melts ice bridge, not enough ice to open curtain | Check purge valve |
| | Incomplete ice formation | Check water distributor for partially plugged holes |
| Curtain out of position | Check curtain for swing restriction | |

C2648 Service Manual

Diagnostics - Remote Air Cooled

| Problem | Likely Cause | Probable Solution |
|---|--|---|
| Shut down on maximum harvest time (continued) | Curtain switch does not open when curtain does | Check switch with ohmmeter |
| | Machine in very cold ambient | Move machine to a warmer location |
| | Hot gas valve does not open | Check hot gas valve, check controller using test mode |
| | Harvest assist probe out of position – ejector pin not retracted | Check harvest assist mechanism – spring should retract pin |
| | Damaged evaporator | Check evaporator surface |
| Shut down on minimum freeze time | Grounded ice thickness sensor or bridge too thin | Check sensor for dirt and position. Clean and adjust gap to evaporator surface using 7/32" drill bit as a gauge |
| | Improper water flow | Check water distributor cover, be sure it is sealed tightly |
| | | Check/clean spillway surface to improve water flow |
| | | |

C2648 Service Manual

Low Ice Making Capacity

| | | |
|-----------------------|--|---|
| Long freeze cycle | Dirty condenser | Clean condenser |
| | Hot ambient | Check condenser inlet temp. |
| | Water leak | Check purge valve, check curtain |
| | Water inlet valve leaks through | Check inlet valve |
| | Low on refrigerant | Add refrigerant, if cycle time drops, check for leak |
| | Incorrect superheat | Check evaporator superheat, if significantly low or high, replace TXV |
| Long Harvest Cycle | Dirty evaporator | De-scale water system |
| | No harvest assist | Check harvest assist solenoid |
| | Bridge thickness too big | Check and adjust bridge thickness |
| | Machine in very cool ambient | Increase room temperature |
| False bin full signal | Ice jammed in between curtain and sump | Clear ice away |
| | Curtain does not close correctly | Check curtain for proper swing |

C2648 Service Manual

Test Procedures - Sensors

All electrical components in this ice machine can be diagnosed with a volt-ohmmeter.

Curtain Switch:

1. Test using the controller's indicator lights. Observe **SW1** and **SW2** and the **Period** in the display code. Open and close the curtain in question. When the curtain is opened, the SW light will be ON. When the curtain gets to within a half inch of closing (at the switch) the SW light will go OUT.
2. Test with an ohmmeter. Disconnect electrical power. Open the control box cover. Unplug the curtain switch lead from the controller. Connect an ohmmeter to the leads of the switch. Open and close the curtain. When the curtain is closed, the switch is closed and there will be continuity - a good curtain switch will have very low resistance when the curtain is closed - .5 to 2 ohms. A defective switch has about 100 or more ohms of resistance when the curtain is closed. When the curtain is open, the switch is open and the circuit will be open.
3. Test the controller's curtain switch circuit by jumping the connectors on J1 or J2 together. Reconnect electrical power. When jumped, the matching SW light will go out. When unplugged or open, the SW light will be ON.

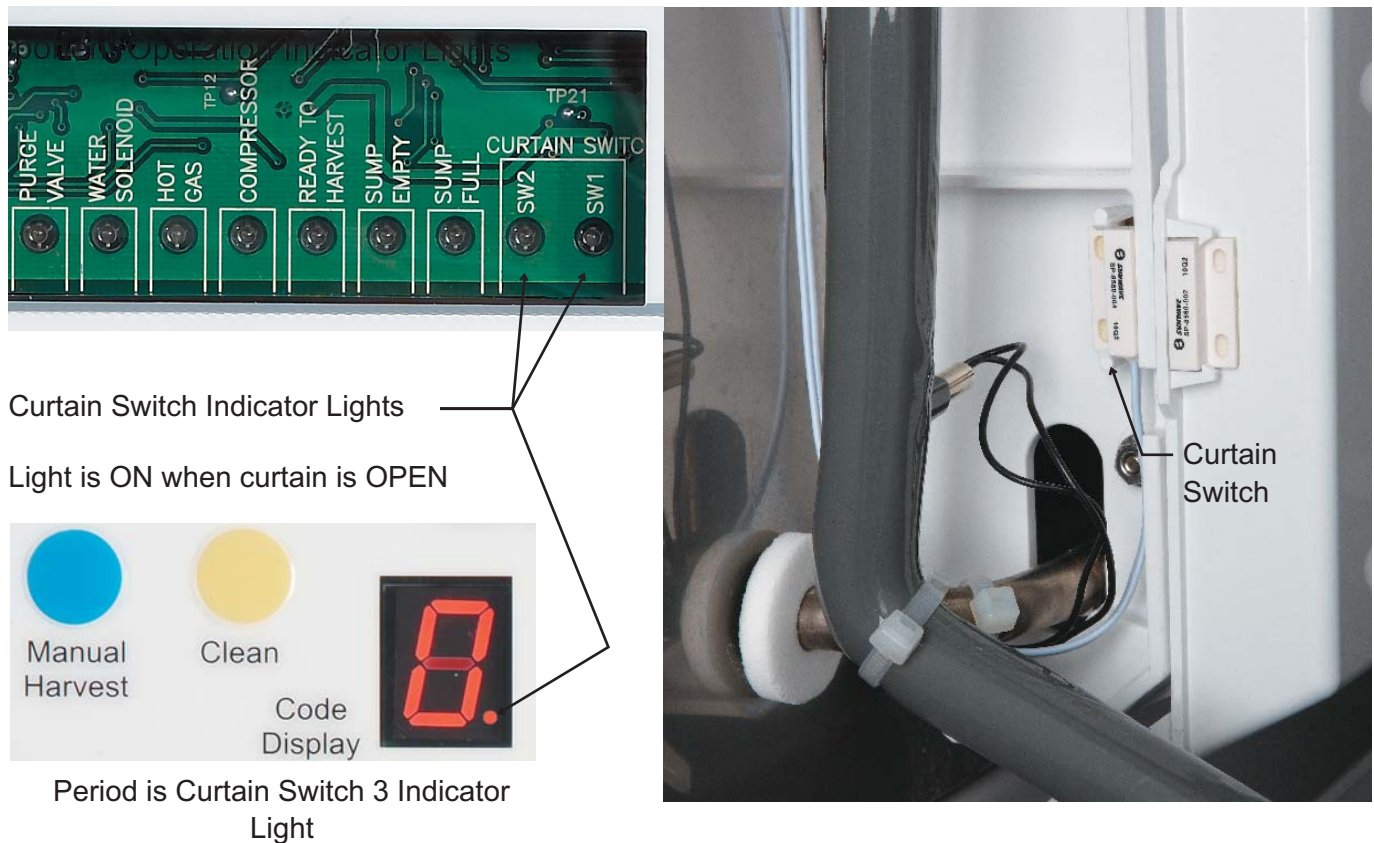

C2648 Service Manual

Ice Thickness Sensor

1. Test using the controller's indicator light. Observe the Ready To Harvest light. Shut the machine off. Use a wire to connect the metal part of the Ice Thickness sensor to the evaporator or simply remove the Ice Thickness Sensor and touch its metal surface to the metal control box wall. The Ready for Harvest light should go ON.
2. Test with an Ohmmeter. Disconnect electrical power. Open the control box cover. Unplug the ice thickness sensor lead from the controller. Connect an ohmmeter lead to the ice thickness sensor lead, touch the other ohmmeter lead to the ice machine chassis. There must be an open circuit. If there is continuity, the sensor must be replaced. If there is no continuity, touch the ohmmeter lead to the metal part of the ice thickness sensor. There should be continuity. If open, check the ice thickness sensor for scale build up. Clean and recheck. If still open, replace the ice thickness sensor.
3. Test the controller's ice thickness sensor circuit by connecting a wire from J10 to ground. Reconnect electrical power. The Ready for Harvest light should go ON

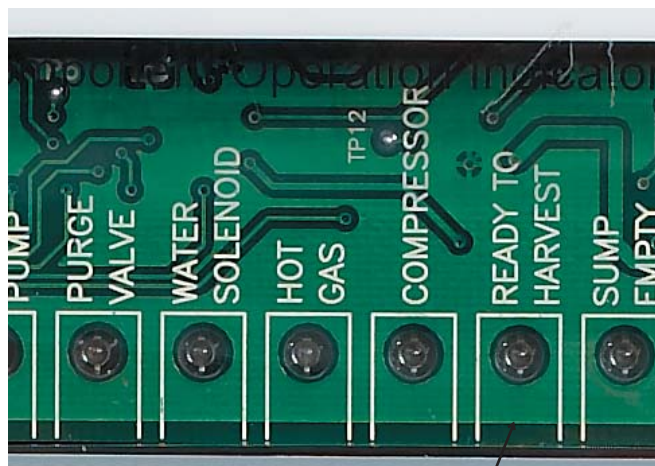

Ready To Harvest light is ON when water contacts ice thickness sensor.



Ice Thickness Sensor

C2648 Service Manual

Water Level Sensor

1. Test using the controller's indicator lights (sump empty and sump full). Unit must be powered up and there must be water in the sump. Add some manually if needed. Locate water level sensor. Release from sump cover and slowly lift up until the mid-length probe is out of the water. The sump empty light should come on, and if the unit is on the inlet water solenoid valve will open to fill the reservoir. Return the water level sensor to its normal position. If the unit is on and calling for ice the water will fill until the top probe is in contact with it, at that time the sump full light will switch ON.
2. Test with an ohmmeter. Disconnect electrical power. Open the control box cover. Unplug the connector at J9. Locate water level sensor and remove it from the sump cover. Test 1: Place one lead of the ohmmeter on the longest probe and the other on the controller end of the red wire, there should be continuity. Test 2: Place one lead on the controller end of the white wire and the other on the mid-length probe, there should be continuity. Test 3: Place one lead on the controller end of the black wire and the other on the shortest probe, there should be continuity. If not, clean the probes and recheck.
3. Test the controller's water level sensor circuit. Reconnect electrical power. Unplug harness from water level sensor, the sump empty light should be ON. Jump harness wires white and black. The sump full light should be ON. Jump harness wires white and red, the sump full and sump empty lights will be OFF. Check harness wire by wire for continuity if there is no reaction from the controller during this test.

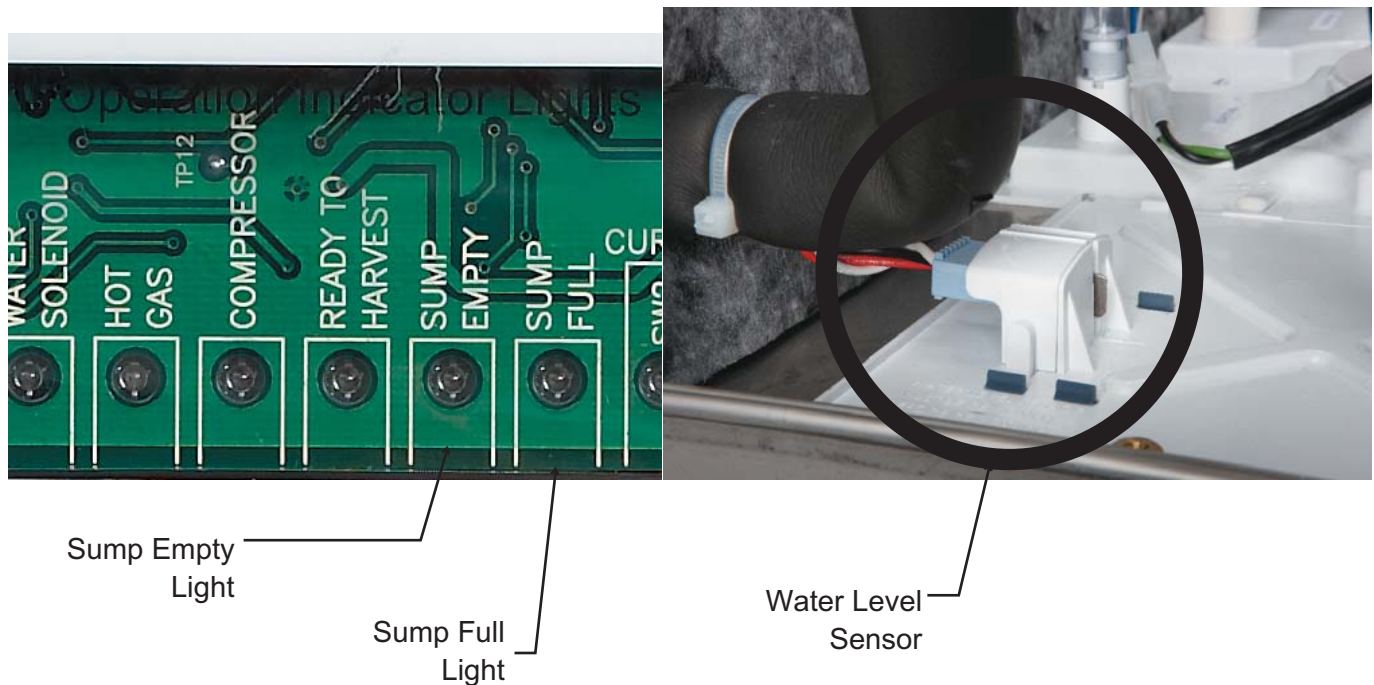

C2648 Service Manual

Temperature Sensors

1. Check controller. If the sensor calibration is completely out of range, the code display will read either 5 or 7.
2. Check with an ohmmeter. Open control box cover, unplug sensor from J6. Water temperature probe: Measure the temperature of the water. Push and release the clean button. Wait one minute. Measure the resistance of the water probe (two leads next to the open socket) and compare to the resistance in the chart for that temperature. Any reading within 1000 ohms is acceptable. Discharge sensor: Measure the temperature of the discharge line as close to the sensor as possible. Measure the resistance of the discharge temperature sensor (two leads farthest away from the open socket on the harness connector) and compare to the resistance in the chart for that temperature. Any reading within 1000 ohms is acceptable.
3. Alternate procedure: Remove both water and discharge sensors from their places on the ice machine. Put both into a container of ice water. Put a thermometer in the water. When the thermometer is at 32 degrees F., check the resistance of each sensor. The resistance should be within 1000 ohms of 32649.

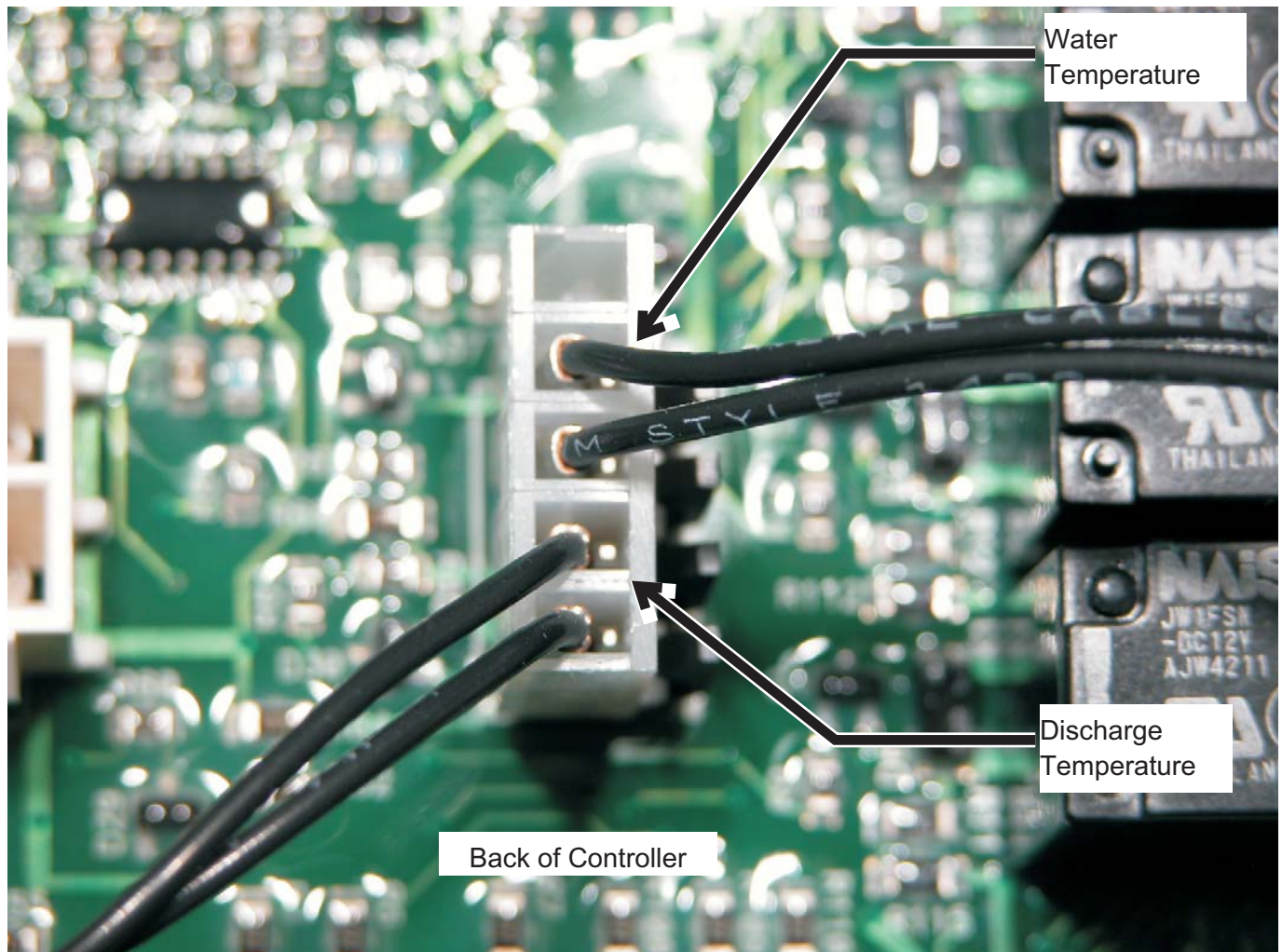

C2648 Service Manual

Test Procedures - Loads

Water Pumps

1. Test using the controller's indicator lights. Check the indicator light during the freeze cycle. The light will be On for all but the 30 second anti-slush period, so observe the light for one minute. When it is On, check the water pumps, both should be operating. If only one is operating check for voltage to that pump, if there is no voltage, replace that pump.

One of the pumps will operate during the part of the drain cycle, when the purge valve light is on. If both are off, check for voltage at the dump valve relay. The coil of that relay should have power when the purge light is on, connecting power to one of the pumps. Check for voltage from the relay to the pump. If there is voltage to the pump and it does not pump water, replace the pump. If there is no voltage at the pump and the purge valve is working, replace the dump valve relay.

2. Test using an ohmmeter. Disconnect electrical power. Unplug the suspect water pump motor leads from the harness. Measure the resistance of the motor windings. If open, replace the pump. Measure resistance to ground. If there is any, replace the pump.

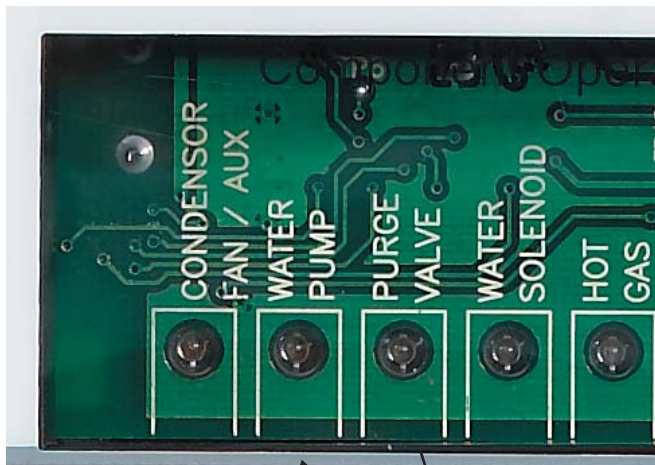

Only one water pump is ON when the purge valve light is ON.

Water pump light is ON when one or both pumps are in operation.

C2648 Service Manual

Test Procedures - Loads

Purge valve

1. Test using the controller's indicator lights. Shut unit off by holding the Off button for 3 seconds. Wait four minutes. Push and release the On button, observe the Purge Valve indicator light. As the unit drains the reservoir, the purge valve will be powered. When it gets power, the indicator light will be ON. If the purge valve does not open to drain the reservoir when its indicator light is on, do a voltage check. Shut the unit down by holding the Off button in for 3 seconds. Unplug the harness connection from the purge valve. Wait four minutes. Push and release the On button to restart the machine. As the unit drains the reservoir, the purge valve connection should receive full voltage. If it does, the purge valve should be replaced. If there is no voltage, check voltage from the controller. The purge valve pin is 3 (dump valve on wiring diagram).

Note: The coil of this valve is internally rectified, and will normally show infinite resistance when tested with an ohmmeter.

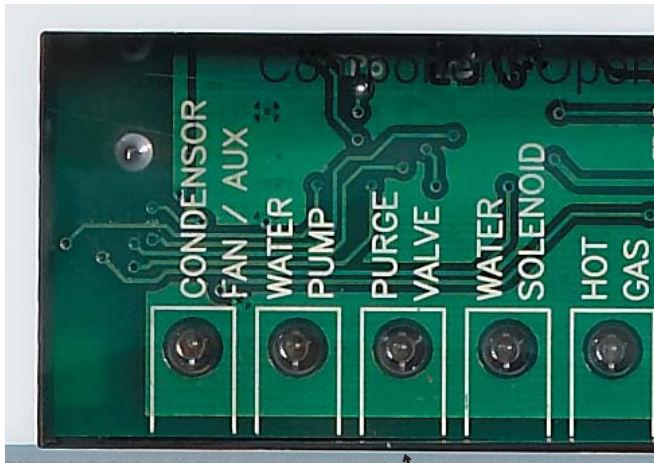

This light will be ON when the Purge Valve is in

C2648 Service Manual

Test Procedures - Loads

Compressor contactor

1. Test using the controller's indicator lights. When the unit is in ice making mode the compressor contactor will have power. Check the Compressor indicator light, when it is on the compressor contactor will have pulled in. If it is not, do a voltage check. Place voltmeter leads on the coil of the contactor. There should be full voltage . If there is full voltage present and the contactor has not pulled in, replace the contactor. If there is no voltage check if the high pressure cut out is open. If the high pressure cut out is closed, check for voltage from the controller. The contactor pin is 4. Check when the compressor indicator light is on. There should be voltage. If not, replace the controller. If there is voltage at the controller but not at the contactor coil, the harness wires or connectors are damaged and must be replaced.
2. Test using an ohmmeter. Test the coil of the contactor for continuity or shorts to ground. Replace if open or shorted.
3. Check connections and contacts. Be sure connections are tight and that the contacts are not burnt. Replace any contactor with burnt contacts.

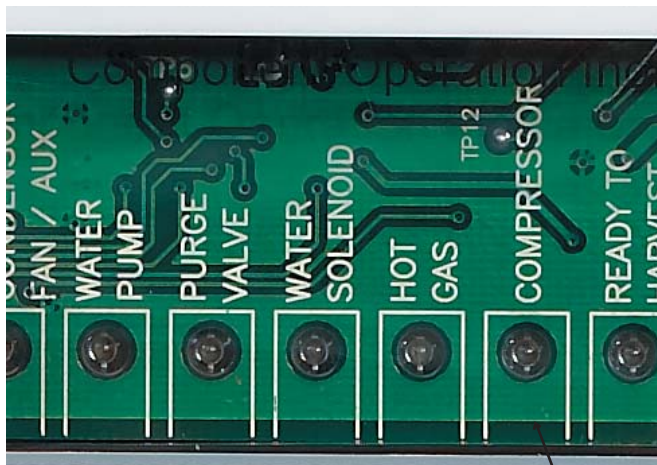

This light will be ON when the compressor contactor is

C2648 Service Manual

Test Procedures - Loads

Pressure switch

High pressure cut out. The high pressure cut out switch will open at a preset pressure, shutting off power to the compressor contactor. After the pressure has fallen to another preset level, the switch will re-close and the contactor coil will be energized.

To Test High Pressure Switch:

A. Attach refrigeration gauge set to high side port.

B. Disconnect leads to fan motor.

C. Measure voltage at high pressure control.

D. Switch ice machine on, observe pressure that the pressure control opens at, compare to spec. Allow system to equalize, observe the pressure that the pressure control closes at, compare to spec.

Transformer

Check secondary voltage, it must be between 10 and 15.5 AC volts. Replace if no voltage is output or if above or below the acceptable voltage..

Controller

The controller's software operation is confirmed if it is functioning. Execute the test to confirm its operation of the loads. Illumination of a diagnostic code (other than E) is not an indication of controller failure. Each code requires its own diagnosis.

C2648 Service Manual

Test Procedures - Loads

Liquid Line Solenoid

1. Test using the controller's indicator lights. Put the controller into test mode (depress Off for 3 seconds then depress Clean for 3 seconds). At the end of the test cycle, the liquid line valve will be powered and the Condenser Fan motor indicator light will be on. The liquid line valve should be open at that time. If it is not, repeat the test but check the voltage to the liquid line valve coil, it must receive full voltage at the liquid line lead connection at the end of the test. If there is voltage and the valve does not operate, replace the valve coil. If there is no voltage, check the controller high voltage harness connection. The liquid line solenoid lead is the top wire. Check voltage at the end of the test, when the Condenser Fan indicator light is On. Note: high voltage power is supplied to the bottom pin from the contactor line. Refer to the machine wiring diagram as needed.
2. Test using an ohmmeter. Disconnect electrical power. Unplug liquid line coil from harness. Measure liquid line coil resistance. If open, replace the liquid line valve coil.

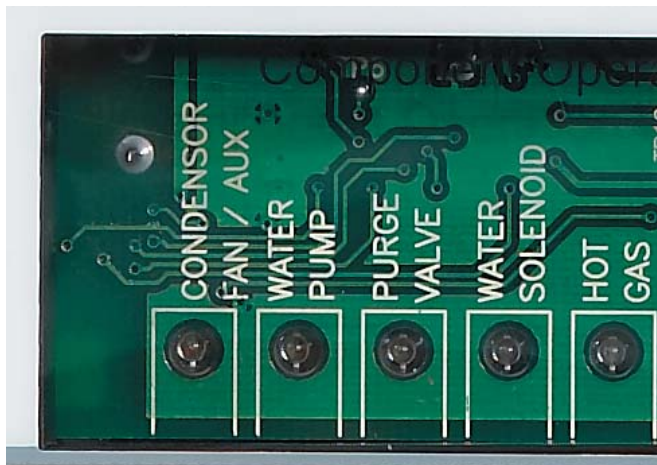

This light will be ON when the liquid line solenoid has power.

C2648 Service Manual

Test Procedures - Loads

Inlet Water Solenoid Valve

1. Test using the controller's indicator lights. Shut unit off by holding the Off button for 3 seconds. Wait four minutes. Push and release the On button, observe the Water Solenoid indicator light. After the unit drains the reservoir, the inlet water valve will be powered to refill the reservoir. When it gets power, the indicator light will be ON. If the water valve does not open to fill the reservoir when its indicator light is on, do a voltage check. Shut the unit down by holding the Off button in for 3 seconds. Unplug the harness connection from the inlet water valve. Wait four minutes. Push and release the On button to restart the machine. After the unit drains the reservoir, the inlet water valve connection should receive full voltage. If it does, the inlet water valve should be replaced. If there is no voltage, check voltage from the controller. The inlet water solenoid valve pin is 7.
2. Test using an ohmmeter. Disconnect electrical power. Unplug coil from harness. Measure coil resistance. If open, replace the inlet water solenoid.

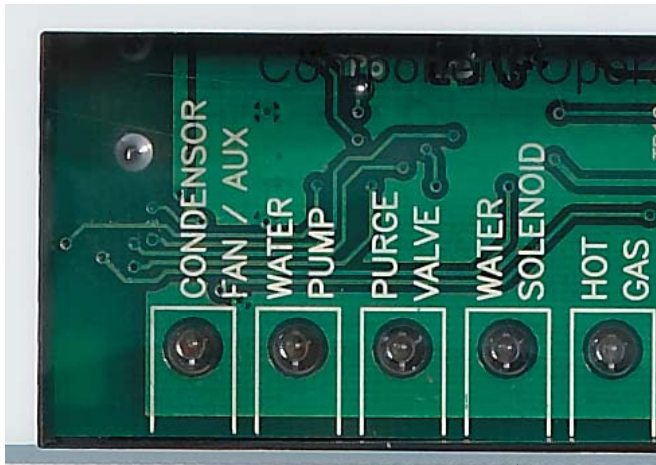

Light is ON when inlet water solenoid is in operation.

C2648 Service Manual

Test Procedures - Loads

Harvest assist solenoid

1. Test using the controller's indicator lights. Push and release the Harvest button. The Hot Gas indicator light will be on. At the same time the Harvest Assist Solenoid will be powered. If the ice on the evaporator is thin, the solenoid will extend. If the ice is nearly full sized, the solenoid will press against the ice until it releases from the evaporator, then the solenoid probe will extend. If the probe extends, the solenoid is good. If not, do a voltage check. Unplug the high voltage harness from the harvest assist solenoid. Attach a voltmeter to the harness connector. Push and release the Harvest button. There should be full voltage at the connector. If there is and the solenoid does not extend, replace the solenoid. If full voltage is not present, check voltage at the controller. If there is no voltage, check voltage from the controller. The hot gas / harvest assist pin is 5.

Note: The coil of this valve is internally rectified, will normally show infinite resistance when tested with an ohmmeter.

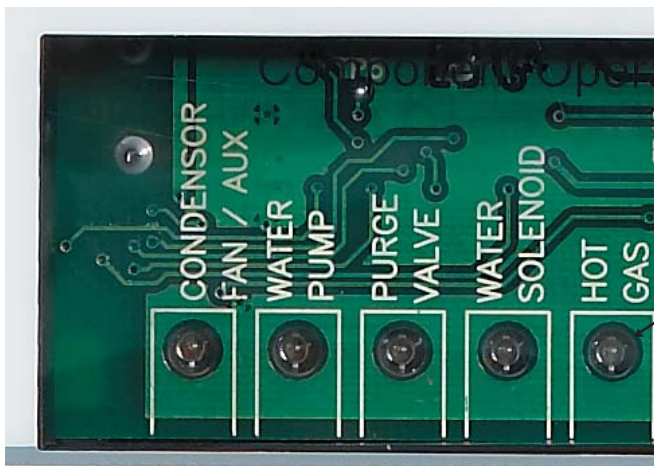

This light will be ON during harvest. Both the Hot Gas Valve coil and the Harvest assist solenoid coil will have power when this light is ON.

Hot Gas or Vapor Valve

1. Test using the controller's indicator lights. If the unit is running, or has been off for more than 4 minutes, push and release the Harvest button. The Hot Gas indicator light will be on and the hot gas valves will be energized. The compressor will force discharge gas into the evaporator inlet, warming it. If the evaporator inlet does not warm up, do a voltage check. Shut the unit off by holding the Off button in for 3 seconds. Unplug the high voltage harness from the hot gas solenoid. Attach a voltmeter to the harness connector. Wait 4 minutes. Push and release the Harvest button. There should be full voltage at the connector. If there is and the solenoid does not open, replace the solenoid coil. If full voltage is not present, check voltage at the controller. If there is no voltage, check voltage from the controller to ground. The hot gas pin is 5.

2. Test with an ohmmeter. Disconnect electrical power. Unplug high voltage harness from hot gas or vapor valve. Measure resistance of hot gas or vapor valve coil. If open, replace the coil.

C2448 Service Manual

Reservoir Removal

The reservoir may be removed from the cabinet if needed.

1. Drain water by holding in the Clean button repeatedly until no more water will drain.
2. Disconnect electrical power.
3. Twist counterclockwise and lift water pumps up and tip to one side.
4. Remove front water reservoir cover plate, set aside.
5. Remove sump cover and water level sensor, set sump cover aside.
6. Pull water reservoir forward; tip up and out of the machine.



C2648 Service Manual

Controller Differences

The controllers are programmed at the factory for the model they are installed on, they cannot be moved from one model to another due to differences in:

- Water purge time per setting
- Maximum harvest time
- Number of evaporator plates

The service controller has a selector switch that allows it to be used as a replacement part in any of the Prodigy models in production at the time the controller was manufactured. As new Prodigy models are introduced, those models will be added to the list of models new service controllers will work with.

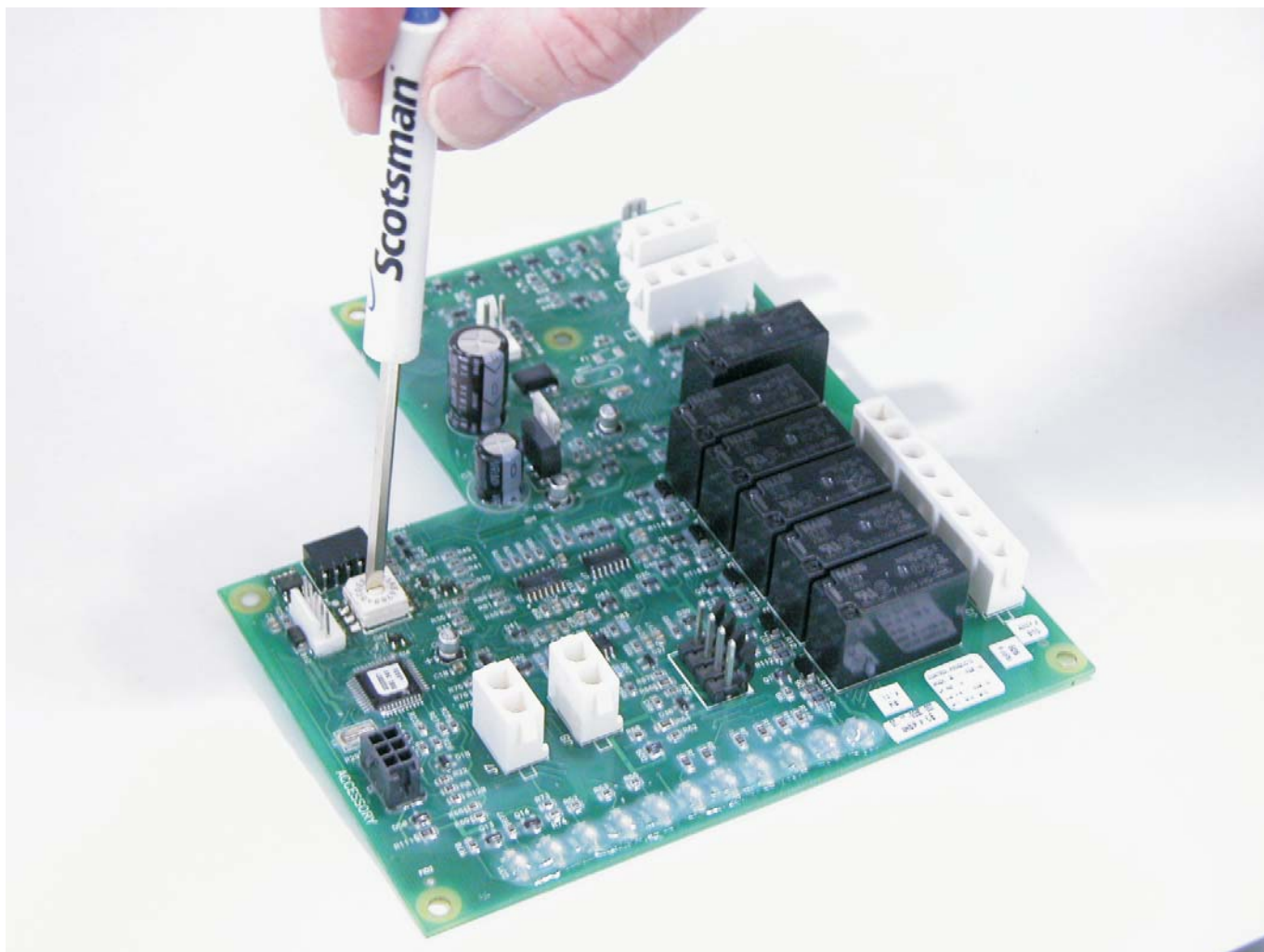

The Service Controller includes a selector switch. The switch must be set to the model the controller is being installed on. As new models are introduced, their setting will be added to service controllers produced after that point.

C2648 Service Manual

Thermistor Values

| Deg. F. . Ohms | Deg. F. . Ohms | Deg. F. . Ohms | Deg. F. . Ohms | Deg. F. . Ohms |
|----------------|----------------|----------------|----------------|----------------|
| 0..... 85325 | 52..... 18873 | 104.... 5325 | 156.... 1819 | 208.... 724 |
| 1..... 82661 | 53..... 18381 | 105.... 5208 | 157.... 1785 | 209.... 713 |
| 2..... 80090 | 54..... 17903 | 106.... 5093 | 158.... 1752 | 210.... 701 |
| 3..... 77607 | 55..... 17439 | 107.... 4981 | 159.... 1719 | 211.... 690 |
| 4..... 75210 | 56..... 16988 | 108.... 4872 | 160.... 1687 | 212.... 679 |
| 5..... 72896 | 57..... 16551 | 109.... 4766 | 161.... 1655 | 213.... 668 |
| 6..... 70660 | 58..... 16126 | 110.... 4663 | 162.... 1624 | 214.... 657 |
| 7..... 68501 | 59..... 15714 | 111.... 4562 | 163.... 1594 | 215.... 646 |
| 8..... 66415 | 60..... 15313 | 112.... 4463 | 164.... 1565 | 216.... 636 |
| 9..... 64400 | 61..... 14924 | 113.... 4367 | 165.... 1536 | 217.... 626 |
| 10.... 62453 | 62..... 14546 | 114.... 4273 | 166.... 1508 | 218.... 616 |
| 11.... 60571 | 63..... 14179 | 115.... 4182 | 167.... 1480 | 219.... 606 |
| 12.... 58752 | 64..... 13823 | 116.... 4093 | 168.... 1453. | 220.... 597 |
| 13.... 56995 | 65..... 13476 | 117.... 4006 | 169.... 1427 | 221.... 587 |
| 14.... 55296 | 66..... 13139 | 118.... 3921 | 170.... 1401 | 222.... 578 |
| 15.... 53653 | 67..... 12812 | 119.... 3838 | 171.... 1375 | 223.... 569 |
| 16.... 52065 | 68..... 12494 | 120.... 3757 | 172.... 1350 | 224.... 560 |
| 17.... 50529 | 69..... 12185 | 121.... 3678 | 173.... 1326 | 225.... 551 |
| 18.... 49043 | 70..... 11884 | 122.... 3601 | 174.... 1302 | 226.... 543 |
| 19.... 47607 | 71..... 11592 | 123.... 3526 | 175.... 1279 | 227.... 534 |
| 20.... 46217 | 72..... 11308 | 124.... 3452 | 176.... 1256 | 228.... 526 |
| 21.... 44872 | 73..... 11031 | 125.... 3381 | 177.... 1234 | 229.... 518 |
| 22.... 43571 | 74..... 10763 | 126.... 3311 | 178.... 1212 | 230.... 510 |
| 23.... 42313 | 75..... 10502 | 127.... 3243 | 179.... 1190 | 231.... 502 |
| 24.... 41094 | 76..... 10247 | 128.... 3176 | 180.... 1169 | 232.... 495 |
| 25.... 39915 | 77..... 10000 | 129.... 3111 | 181.... 1149 | 233.... 487 |
| 26.... 38774 | 78..... 9760 | 130.... 3047 | 182.... 1129 | 234.... 480 |
| 27.... 37669 | 79..... 9526 | 131.... 2985 | 183.... 1109 | 235.... 472 |
| 28.... 36600 | 80..... 9299 | 132.... 2924 | 184.... 1090 | 236.... 465 |
| 29.... 35564 | 81..... 9077 | 133.... 2865 | 185.... 1071 | 237.... 458 |
| 30.... 34561 | 82..... 8862 | 134.... 2807 | 186.... 1052 | 238.... 451 |
| 31.... 33590 | 83..... 8652 | 135.... 2751 | 187.... 1034 | 239.... 444 |
| 32.... 32649 | 84..... 8448 | 136.... 2696 | 188.... 1016 | 240.... 438 |
| 33.... 31738 | 85..... 8250 | 137.... 2642 | 189.... 998 | 241.... 431 |
| 34.... 30855 | 86..... 8056 | 138.... 2589 | 190.... 981 | 242.... 425 |
| 35.... 30000 | 87..... 7868 | 139.... 2537 | 191.... 965 | 243.... 419 |
| 36.... 29171 | 88..... 7685 | 140.... 2487 | 192.... 948 | 244.... 412 |
| 37.... 28368 | 89..... 7507 | 141.... 2438 | 193.... 932 | 245.... 406 |
| 38.... 27589 | 90..... 7333 | 142.... 2390 | 194.... 916 | 246.... 400 |
| 39.... 26835 | 91..... 7164 | 143.... 2343 | 195.... 901 | 247.... 394 |
| 40.... 26104 | 92..... 6999 | 144.... 2297 | 196.... 885 | 248.... 389 |
| 41.... 25395 | 93..... 6839 | 145.... 2252 | 197.... 871 | 249.... 383 |
| 42.... 24707 | 94.... 6683 | 146.... 2208 | 198.... 856 | 250.... 377 |
| 43.... 24041 | 95.... 6530 | 147.... 2165 | 199.... 842 | |
| 44.... 23394 | 96.... 6382 | 148.... 2123 | 200.... 828 | |
| 45.... 22767 | 97.... 6238 | 149.... 2082 | 201.... 814 | |
| 46.... 22159 | 98.... 6097 | 150.... 2042 | 202.... 800 | |
| 47.... 21569 | 99.... 5960 | 151.... 2003 | 203.... 787 | |
| 48.... 20997 | 100... 5826 | 152.... 1965 | 204.... 774 | |
| 49.... 20442 | 101... 5696 | 153.... 1927 | 205.... 761 | |
| 50.... 19903 | 102... 5569 | 154.... 1890 | 206.... 749 | |
| 51.... 19381 | 103... 5446 | 155.... 1855 | 207.... 737 | |

C2648 Service Manual

Performance Information

| | | Condenser Intake Air Temp., Degrees F | | | | |
|------------------------------|---------------|---------------------------------------|---------|---------|---------|---------|
| | | -20 | 70 | 80 | 90 | 120 |
| Cycle Time (minutes) | Water Temp | | | | | |
| | 50 | 9-11 | 10-12 | 11-13 | 12-14 | 16-18 |
| | 70 | 10-12 | 11-13 | 12-14 | 13-15 | 17-19 |
| | 80 | 11-13 | 12-14 | 13-15 | 14-16 | 18-20 |
| | 90 | 12-14 | 13-15 | 14-16 | 15-17 | 19-21 |
| Suction Pressure (PSIG) | End of Freeze | 28-30 | 26-28 | 27-29 | 27-30 | 34-36 |
| | Harvest | 73-75 | 78-80 | 78-80 | 78-80 | 86-89 |
| Discharge Pressure (PSIG) | End of Freeze | 205-210 | 230-235 | 238-243 | 245-250 | 365-370 |
| | Harvest | 150-155 | 170-175 | 178-183 | 195-190 | 245-255 |

Ice per cycle, 21 lb.

Compressor Amps:

- Freeze - 13.2 to 12.9, declining to 9.6 at the end of the freeze cycle. 11.6 to 11.9 at five minutes.
- Harvest - 12.7 to 11.8

C2648 Service Manual

Repair Procedures

Inlet Water Solenoid Valve

- 1 Disconnect electrical power
- 2 Shut off the water supply.
- 3 Remove front panel.
- 4 Unplug wire from coil.
- 5 Disconnect water supply tube from the inlet of the valve.
- 6 Disconnect the water outlet tube.
- 7 Remove the two mounting screws holding the valve to the center panel.
- 8 Pull the valve forward and out of the machine.
- 9 Reverse to reassemble.

| | |
|--|---|
|  | ⚠ WARNING |
| | Electrical Shock Hazard. Disconnect electrical power before beginning. |



C2648 Service Manual

Harvest Assist Solenoid

- 1 Remove front panel.
- 2 Push and release Manual Harvest button
- 3 Disconnect electrical supply

| | |
|---|---|
|  | ⚠ WARNING |
| | Electrical Shock Hazard. Disconnect electrical power before beginning. |

- 4 Unplug wires from solenoid
- 5 Remove screws holding solenoid coil to upper bracket. **Note: Upper bracket stays in unit.**



Harvest Assist Solenoid

- 6 Remove bottom two screws holding bracket and solenoid to cabinet (see circled area). Remove coil from unit.
- 7 Remove and replace plunger

Reverse to reassemble.

C2648 Service Manual

Repair Procedures

Ice thickness sensor

- 1 Push and release the Off switch.
- 2 Remove front and top panels.
- 3 Push and release the Harvest switch
- 4 Remove the evaporator cover.
- 5 Disconnect electrical power.

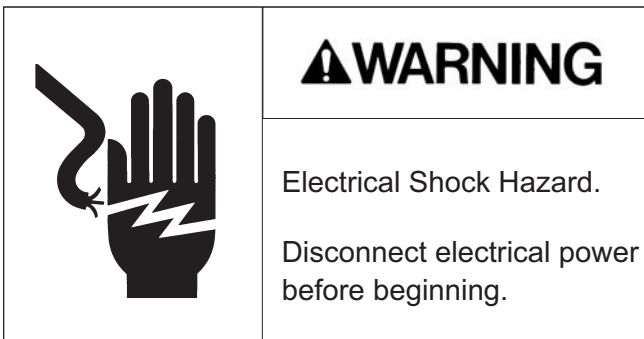

- 6 Open the control box.
- 7 Remove curtain.
- 8 Locate sensor, squeeze mounting legs together to release it from the mounting bracket.
- 9 Remove sensor, follow wire back to control box.
- 10 Disconnect from controller connection J10.
- 11 Remove sensor from machine.
- 12 Reverse to reassemble.

Set initial probe-to-evaporator-surface gap using a 7/32" drill bit as a gauge.

C2648 Service Manual

Repair Procedures

Contactors

- 1 Disconnect electrical power.

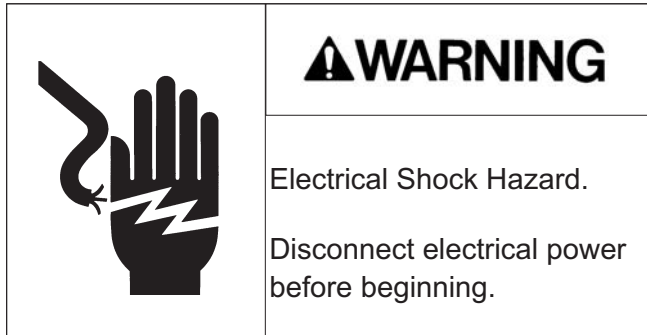

- 2 Remove front panel.
- 3 Open control box cover.
- 4 Remove right side of control box.
- 5 Remove metal barrier from control box
- 6 Remove mounting screws holding contactor to control box.
- 7 Exchange wires from old controller to new. Refer to wiring diagram as needed.

Reverse to reassemble.

C2648 Service Manual

Repair Procedures

Controller

- 1 Disconnect electrical power.

| | |
|---|---|
|  | ⚠ WARNING |
| | Electrical Shock Hazard. Disconnect electrical power before beginning. |

- 2 Remove front panel.
- 3 Open control box door.
- 4 Unplug all wires from controller.
- 5 Remove screws holding controller to door
- 6 Push controller snaps down and pull controller from mounting bracket.
- 7 Before touching new controller, discharge any static electricity by touching the metal surface of the ice machine cabinet.
- 8 Rotate selector switch to the proper model number for the machine the controller is being installed on.
- 9 Install new controller on mounting bracket, secure with original screws.

Note: Be SURE the controller is snapped into place and all screws returned to their original spots.

- 10 Attach all wires removed.
- 11 Shut control box cover.
- 12 Switch on the electrical power.



Controller's Model Selector Switch

C2648 Service Manual

Repair Procedures

Curtain

- 1 Push and hold the Off button to shut the machine off.
- 2 Remove front panel.
- 3 Remove evaporator cover.
- 4 Push inside tab in to release front curtain pin from holder.
- 5 Pull curtain from machine.
- 6 Reverse to reassemble.
- 7 Push and release the ON button to restart the machine.

Curtain switch

- 1 Push and hold the Off button to shut the machine off.
- 2 Disconnect electrical power

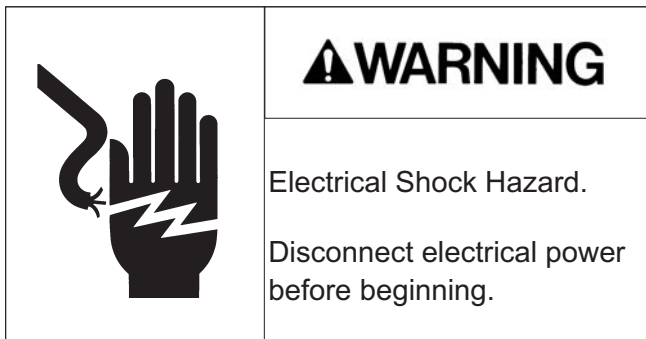

- 3 Remove front panel.
- 4 Remove evaporator cover.
- 5 Open control box.
- 6 Locate curtain switch on evaporator mounting bracket. Pull switch from its snaps.
- 7 Dismount wires from sump cover and remove from J7 or J8 connector on control board.
- 8 Reverse to reassemble. Be sure wires are re-mounted to sump cover edge.

C2648 Service Manual

Repair Procedures

Purge valve

- 1 Push and hold the Off button to shut the machine off.
- 2 Disconnect electrical power.
- 3 Remove front panel.
- 4 Unplug wires from valve coil.

| | |
|--|---|
|  | ⚠ WARNING |
| | Electrical Shock Hazard. Disconnect electrical power before beginning. |

Note: The coil can be removed from the valve body by rotating it 1/8 turn CW. After removal of the coil the spring and plunger can be taken out.

- 5 Loosen screws holding valve bracket to mounting bracket (circled area in photo).
- 6 Remove inlet and outlet hoses
- 7 Lift the valve and bracket up and off the keyhole slots. Remove valve from cabinet.
- 8 Remove valve from bracket.
- 9 Reverse to reassemble
- 10 Push and release the On button to restart the machine



Water level sensor

- 1 Push and hold the Off button until the machine shuts off.
- 2 Remove the front panel.
- 3 Locate water level sensor.
- 4 Squeeze the locking tabs together and pull the sensor up and out of the sump.
- 5 Unplug the electrical connection from the sensor.
- 6 Reverse to reassemble.

C2648 Service Manual

Repair Procedures

Water pumps

There are two water pumps. The front pump forces water to the two left evaporators and the back pump waters the right evaporator and drains the reservoir.

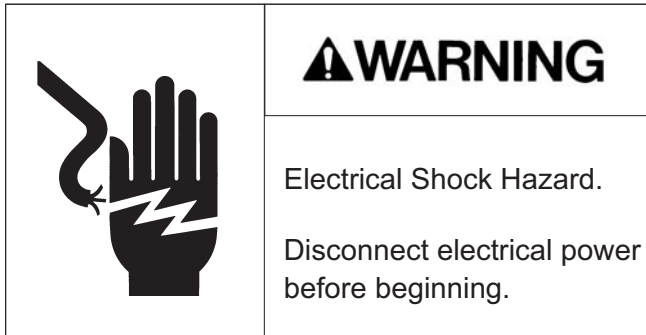

- 1 Push and hold the Off button until the machine shuts off.
- 2 Remove the front panel.
- 3 Unplug the water pump
- 4 Rotate the pump CCW about 1/8 turn to release it.
- 5 Lift pump up and remove hose
- 6 Attach hose to new pump
- 7 Install in pump bracket.
- 8 Rotate CW about 1/8 turn to lock it in place.
- 9 Plug pump into harness
- 10 Return panels to their original positions and secure with the original screws.
- 11 Push and release the ON button to restart the machine.

C2648 Service Manual

Refrigeration Removal and Replacement Procedures

Evaporator

- 1 Remove front panel.
- 2 Remove evaporator cover.
- 3 Remove right side panel.
- 4 Remove top panel.
- 5 If the machine was in operation, push and release the Harvest button to warm up the evaporator.
- 6 Disconnect electrical power.

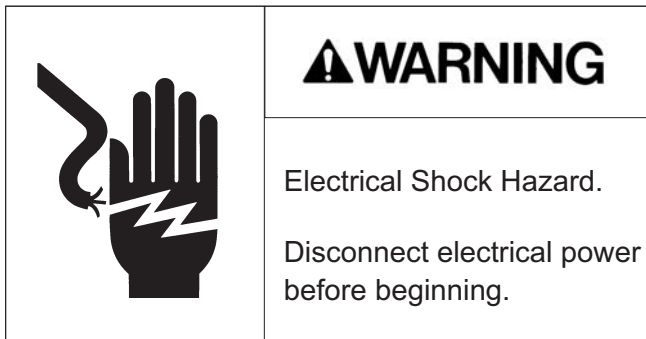

- 7 Remove harvest assist solenoid
- 8 Recover refrigerant.
- 9 Remove curtain
- 10 Remove water distributor
- 11 Release ice thickness sensor
- 12 Remove water distributor bracket from the top of the evaporator
- 13 Connect nitrogen bottle to discharge access port. Open both access valves.
- 14 Open nitrogen valve
- 15 Unsweat the inlet and outlet refrigerant tubes. Use caution when heating the tubing, do not damage the freezing compartment walls.
- 16 Shut nitrogen valve.

C2648 Service Manual

Refrigeration Removal and Replacement Procedures

- 17 Gain access to the right side of the unit. Remove mounting screws holding the evaporator to the freezing compartment wall. Note: fastener size is 5/16" hex.
- 18 Remove the evaporator from the ice machine.
- 19 Attach new evaporator to freezing compartment wall.
- 20 Install the harvest assist solenoid.
- 21 Open nitrogen valve
- 22 Reconnect inlet and outlet tubes by brazing the copper tubes together.
- 23 Replace filter drier.
- 24 Shut access valves, remove nitrogen bottle.
- 25 Evacuate to at least 300 microns.
- 26 Weigh in the nameplate charge. Check for leaks.
- 27 Return ice thickness sensor bracket, ice thickness sensor, water distributor, curtain and evaporator cover to their original positions.
- 28 Reconnect electrical power.
- 29 Return front panel to the original position.

C2648 Service Manual

Refrigeration Removal and Replacement Procedures

Compressor

- 1 Remove front panel.
- 2 If the machine was in operation, push and release the Harvest button to shut it down. Wait until the harvest cycle has ended so the evaporator has no ice on it.
- 3 Open the replacement compressor box. Check the compressor nameplate, be SURE that the replacement compressor is the correct one for the unit.
- 4 Disconnect electrical power.

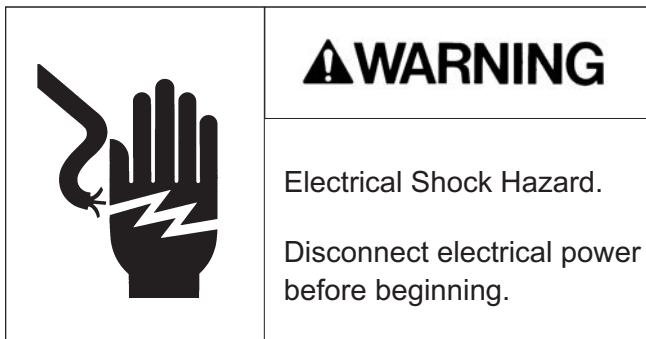

- 5 Recover refrigerant.
- 6 Remove compressor terminal cover and disconnect electrical leads.
- 7 Remove all the mounting bolts.
- 8 Open both discharge and suction access valves
- 9 Connect nitrogen to discharge access valve.
- 10 Open nitrogen valve.
- 11 Unsweat the suction, discharge and process tubes.
- 12 Unsweat the drier from the liquid line. Remove it.
- 13 Shut the nitrogen valve.
- 14 Remove the compressor from the ice machine. Note: Some models may require the control box to be moved slightly to allow compressor replacement.
- 15 Immediately place new compressor in ice machine.

C2648 Service Manual

Refrigeration Removal and Replacement Procedures

- 16 Open nitrogen bottle and braze compressor suction, discharge and process joints together. Braze new drier into system.
- 17 Shut off nitrogen, shut access valves.
- 18 Evacuate to at least 300 microns.
- 19 Weigh in the nameplate charge. Check for leaks.
- 20 Reconnect electrical leads.
- 21 Attach compressor terminal cover.
- 22 Reconnect electrical power.
- 23 Return sound shield and front panel to their original positions.

Note: If the compressor is being returned for warranty, braze the stubs shut and tag the compressor with the required information.

C2648 Service Manual

Refrigeration Removal and Replacement Procedures

Thermostatic Expansion Valve

- 1 Remove front panel.
- 2 If the machine was in operation, push and release the Harvest button to shut it down. Wait until the harvest cycle has ended so the evaporator has no ice on it.
- 3 Disconnect electrical power.
- 4 Recover refrigerant.
- 5 Remove insulation covering expansion valve and bulb.
- 6 Remove strap securing bulb to suction line.
- 7 Open both discharge and suction access valves
- 8 Unsweat the expansion valve from the liquid line. Remove it.
- 9 Unsweat the drier from the liquid line. Remove it.
- 10 Connect nitrogen to discharge access valve.
- 11 Immediately place new valve in ice machine.
- 12 Open nitrogen bottle and braze expansion valve inlet and outlet joints together. Braze new drier into system.
- 13 Shut off nitrogen, shut access valves.
- 14 Evacuate to at least 300 microns.
- 15 Weigh in the nameplate charge. Check for leaks.
- 16 Attach bulb to suction line. Position at 4 or 8 o'clock on the tube. Secure tightly but do not crush the bulb with the strap.
- 17 Attach valve and bulb insulation.
- 18 Reconnect electrical power.
- 19 Return front panel to its original position.

C2648 Service Manual

Vari-Smart™ Adjustable ice level option

The adjustable ice level control is an optional add-on system consisting of an control board, label and sensor.

The control board fits above the standard control and connects to it using connector J4. The sensor mounts to the base of the ice machine through a hole in the base.

The control has an adjustment knob. Rotating the knob CW lowers the maximum ice level that the ice machine will maintain in the bin or dispenser. When the ice level is at or above maximum for the setting, the bin full light on the ultrasonic board will be ON.



Ultrasonic Board and Cable

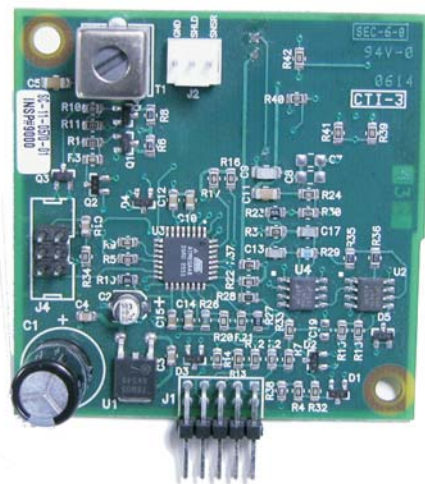

Back View of Ultrasonic Board

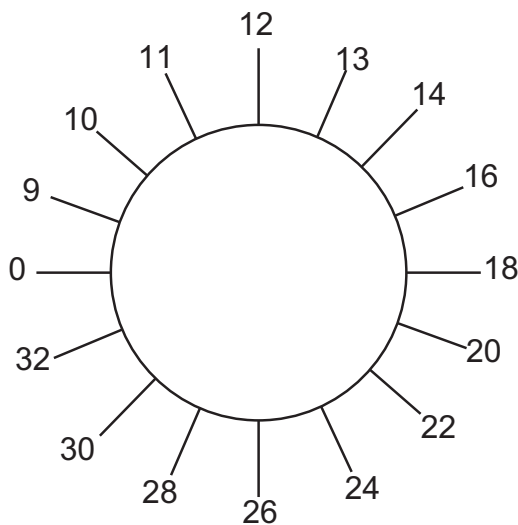

Ultrasonic ice level control settings

0 = controlled by the curtain switch



Ultrasonic control shown in its installed position, set at maximum fill.

C2648 Service Manual

Adjustable Ice Level System Information and Diagnosis

The ultrasonic sensor in the base of the ice machine is located to take advantage of the natural slope of the ice as it builds up in the bin. The numbers of the settings are from the sensor to the top of the ice pile directly under the sensor.

If the Vari-Smart system fails to shut off the machine and ice overfills the bin or dispenser, the curtain switch in the machine will switch the machine off, and will also restart the machine when ice is removed.

Note: Additional information on this option is included with the instructions provided with it.

Vari-Smart Check Out

If the machine's sump water is below 40 degrees or so, the Vari-Smart will only signal Bin Full at the end of a harvest cycle. If above 40, it should do so at the beginning of freeze. The easiest way to check it is as follows:

1. Install the Vari Smart on the Prodigy.
2. Set the Vari-Smart on 32" (point the arrow to the A in Adjust)
3. Connect power to the unit.
4. Put the unit into a Manual Harvest
5. Position something about 12" from the sensor. The object should be a solid, flat item like a panel or manual.
6. Cycle the curtain switch to terminate harvest (open and close all three curtains).
7. The unit should shut off on bin full at the end of the harvest cycle. The Bin Full light will be on and a *b* will show in the code display of the controller.
8. Rotate the selector to the correct position and restart the ice machine.

Note: If a Smart-Board is on the machine, and it is controlling the Vari-Smart, rotating the Vari-Smart's knob will have no affect. The Smart-Board's control will have to be disengaged to perform this check out.

C2648 Service Manual

Prodigy's Smart-Board™ - an Advanced Feature Control

An optional control is available that can provide users with more features. It is available either as a field installed option or as a data-logger that can be used by the service technician.

The kit number for the add on option is: KSBU

The kit number for the data logger version is: TPD2L

The Smart-Board can be applied to most Prodigy models. It can be used:

- With the standard controller
- With the standard controller and the SmartLock device (KSL)
- With the standard controller and the Vari-Smart™ Ice Level Control (KVS)
- With the standard controller, and both the KSL and the KVS

Smart-Board abilities include:

- Ethernet connection
- USB connection to be used with Scotsman's Prodigy TechTool software
- Data Logging
- Data Display

The Smart-Board mounts to the control box door just below the main controller. The cable connecting the two routes from the main controller Accessory connector to J1 of the Smart-Board.

If the datalogger version is used, it plugs into the Accessory connector of the main controller.

If a SmartLock device is also connected, the SmartLock cable must be moved from the Accessory connector to the RLO connector of the SmartBoard.

Features and use instructions are included with either the KSB or the TPD2L.

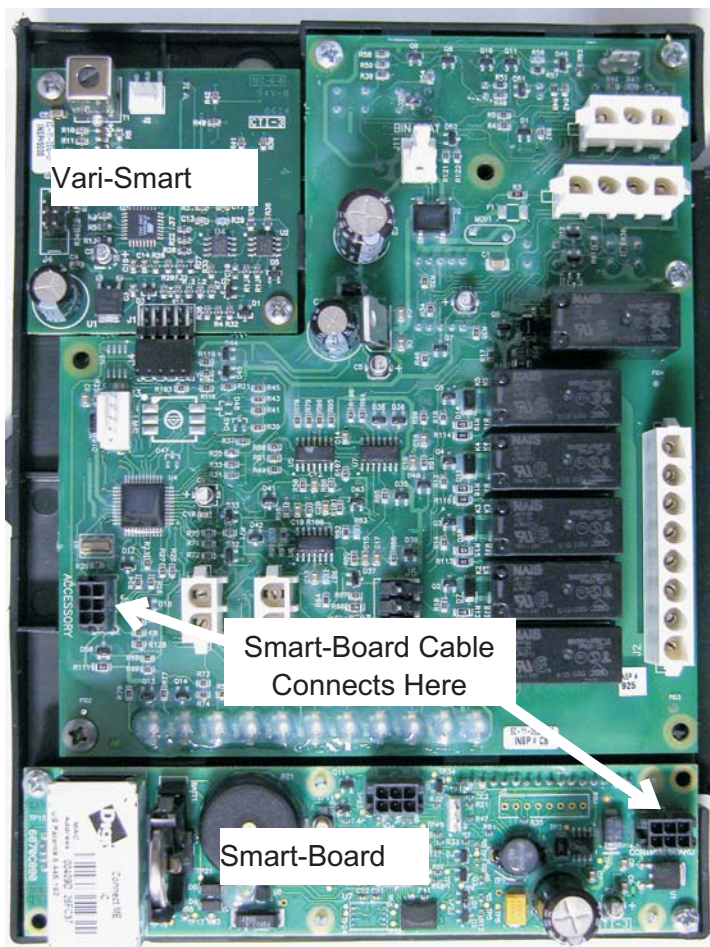

Back of Controller, with SmartBoard and Vari-Smart Options installed.

C2648 Service Manual

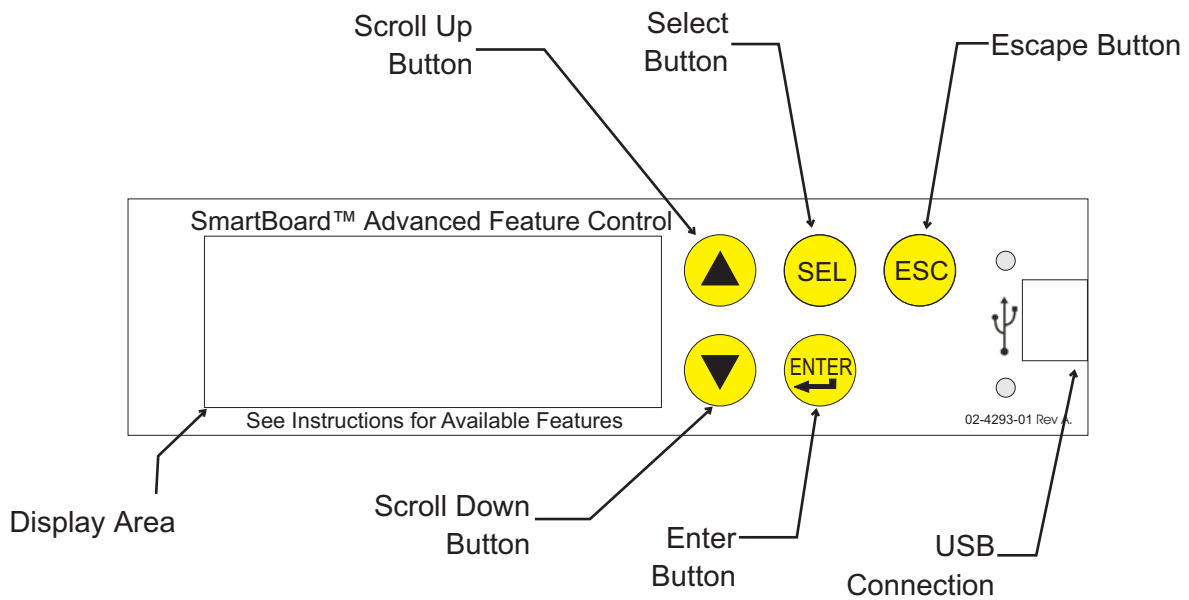

Scroll Up: Changes the display to a menu item higher on the menu list or goes up one number on a setting

Scroll Down: Changes the display to a menu item lower on the menu list or goes down one number on a setting

Select Button: Use to make changes to settings.

Enter Button: Changes display to a sub menu list.

Escape Button: Changes display to the main menu.

The SmartBoard can display Alerts and Data.

Alerts:

- Service ice machine soon
- Slow water fill
- Long freeze cycle
- Long harvest cycle
- High discharge temperature

Note: Additional information on this option is included with the instructions provided with it.