

INTRODUCTION

To the owner or user: The service manual you are reading is intended to provide you, and the maintenance or service technician with the information needed to install, start up, clean, maintain, and service this ice maker-dispenser.

The machine is a combination nugget ice maker and countertop dispenser, with the option of wall mounting.

The ice making section is equipped with the following features: electronic controls for bin level and low water; thermostatic expansion valve; front service for most components; and R-404A refrigerant. The ice dispensing section is a seamless plastic storage bin, with a stainless steel rotating vane to sweep the ice into the dispensing chute.

Table of Contents

FOR THE INSTALLER: Specifications	Page 2
FOR THE INSTALLER: Environmental Limitations	Page 3
FOR THE INSTALLER	Page 4
FOR THE INSTALLER: Wall Mount Kit	Page 5
FOR THE PLUMBER	Page 6
FOR THE ELECTRICIAN	Page 7
FOR THE INSTALLER: Final Check List	Page 8
INITIAL START UP	Page 9
COMPONENT DESCRIPTION	Page 10
COMPONENT DESCRIPTION	Page 11
COMPONENT DESCRIPTION: Control Box	Page 12
ELECTRICAL SEQUENCE	Page 13
OPERATION: Water	Page 14
OPERATION: Refrigeration	Page 15
OPERATION: Ice Vending	Page 16
DISPENSE AREA SANITATION	Page 17
CLEANING and SANITIZING	Page 18
MAINTENANCE AND CLEANING	Page 19
SERVICE DIAGNOSIS	Page 21
SERVICE DIAGNOSIS: Circuit Board	Page 23
REMOVAL AND REPLACEMENT	Page 24
REMOVAL AND REPLACEMENT: Bearing And Breaker	Page 25
REMOVAL AND REPLACEMENT: Water Seal	Page 27
TO REMOVE AND REPAIR THE GEARMOTOR ASSEMBLY	Page 29
REFRIGERATION SERVICE: R-404A (HP62)	Page 30
REFRIGERATION SERVICE	Page 31
CIRCUIT BOARD SERVICE	Page 32
LIQUID CHARGING	Page 32

Parts Lists and Wiring Diagrams are printed on yellow paper in the center of this manual.

This manual was printed on recycled paper.
Keep it for future reference.

Note this symbol when it appears.



It marks a possible hazard.

MDT5N25 & MDT5N40

FOR THE INSTALLER: Specifications

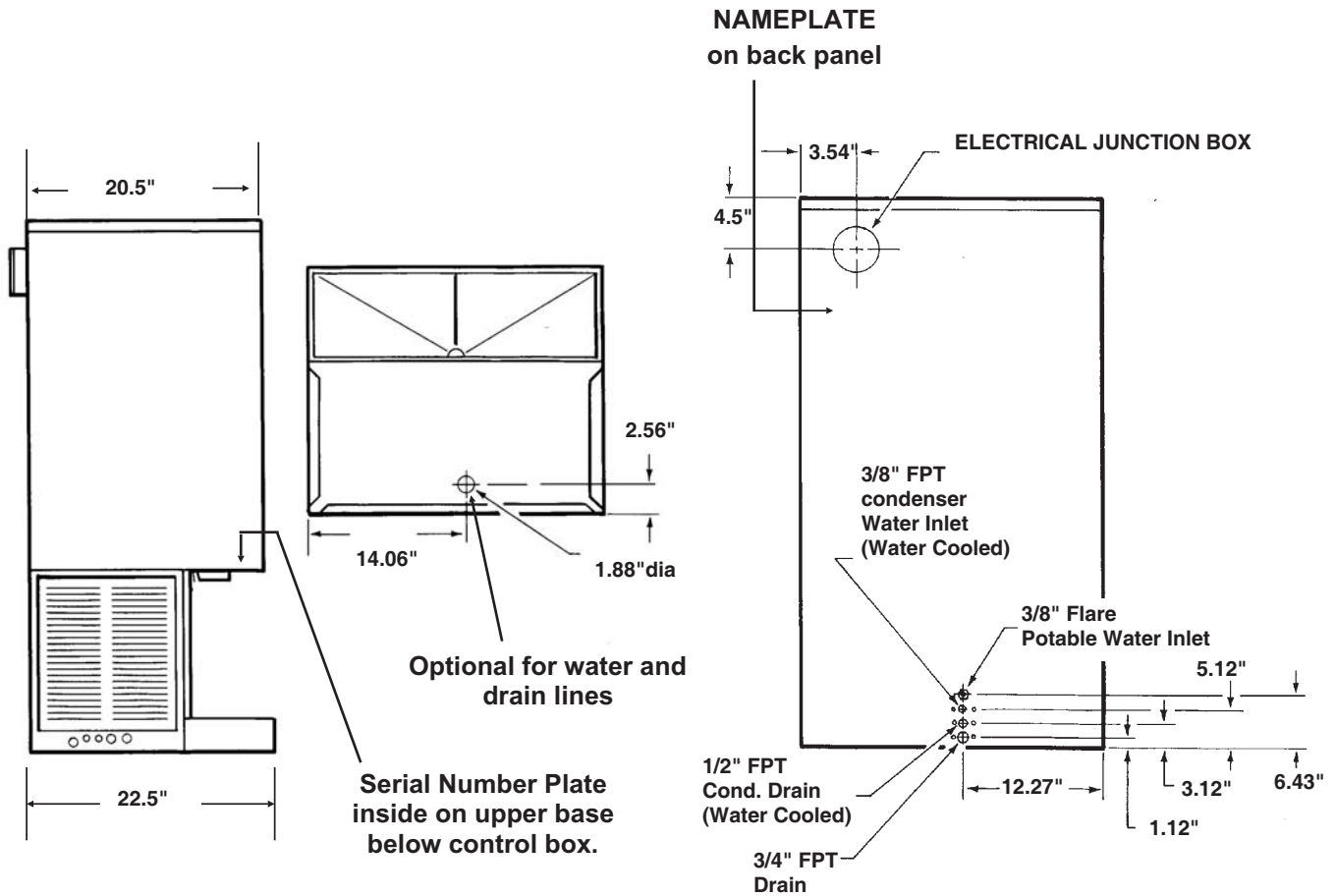

SPECIFICATIONS

Model Number	Dimensions (w/o stand) H" x W" x D"	Basic Electric	Cond. Type	Ref. Charge, R-404A in ounces*	Minimum Circuit Ampacity	Maximum Fuse Size
MDT5N40A-1J	48.5 x 26 x 22.5	115/60/1	Air	24	19.3	25
MDT5N40W-1J	48.5 x 26 x 22.5	115/60/1	Water	17	17.8	20
MDT5N25A-1J	41 x 26 x 22.5	115/60/1	Air	24	19.3	25
MDT5N25W-1J	41 x 26 x 22.5	115/60/1	Water	17	17.8	20
MDT5N40A-1B	48.5 x 26 x 22.5	115/60/1	Air	24	19.3	25
MDT5N40W-1A	same	115/60/1	Water	18	17.8	20
MDT5N40W-1B	same	115/60/1	Water	17	17.8	20
MDT5N40A-6B	same	230/50/1	Air	24	11	15
MDT5N40W-6A	same	230/50/1	Water	18	10.4	15
MDT5N40W-6B	same	230/50/1	Water	17	10.4	15
MDT5N25A-1B	41 x 26 x 22.5	115/60/1	Air	24	19.3	25
MDT5N25W-1A	same	115/60/1	Water	18	17.8	20
MDT5N25W-1B	same	115/60/1	Water	17	17.8	20
MDT5N25A-6B	same	230/50/1	Air	24	11	15
MDT5N25W-6A	same	230/50/1	Water	18	11	15
MDT5N25W-6B	same	230/50/1	Water	17	11	15

* Refrigerant charge change between A and B water cooled. Always check the nameplate for charge info.

MDT5N25 & MDT5N40

FOR THE INSTALLER: Environmental Limitations

Installation Limitations

This ice system is designed to be installed indoors, in a controlled environment.

	Minimum	Maximum
Air Temp	50°F.	100°F.
Water Temp	40°F.	100°F.
Water Pressure	20 PSI	80 PSI
Voltage (115v)	104	126

Operating the machine outside of the above limitations, or outdoors, is potentially damaging to the machine; also it is misuse of the machine, which may void the warranty.

Scotsman Ice Systems are designed and manufactured with the highest regard for safety and performance. They meet or exceed the standards of UL and NSF.

Scotsman assumes no liability or responsibility of any kind for products manufactured by Scotsman that have been altered in any way, including the use of any part and/or other components not specifically approved by Scotsman.

Scotsman reserves the right to make design changes and/or improvements at any time.

Specifications and design are subject to change without notice.

Water Limitations

An ice machine is a food manufacturing plant; it takes a raw material, water, and turns it into a food product, ice. The purity of the water is very important in obtaining pure ice and in maximizing product life. This section is not intended as a complete resource for water questions, but it does offer these general recommendations:

1. Filter the water used to produce ice. That is the water going to the "potable" water connection. Water filters vary greatly in ability and function. Install one that filters out suspended solids to a dimension of 5 microns or smaller. The finer the filter the better, but finer filters will clog sooner than course ones. It may be necessary to add a course filter ahead of the fine filter to prolong filter life.
2. Check with a water treatment specialist for a water test, and recommendations regarding filters and treatment.

Service Limitations

Do not install in a location where the top of the machine is within 6" of a fixed ceiling. Do not install air cooled models in a location where there is less than 6" clearance to the left and right of the cabinet.

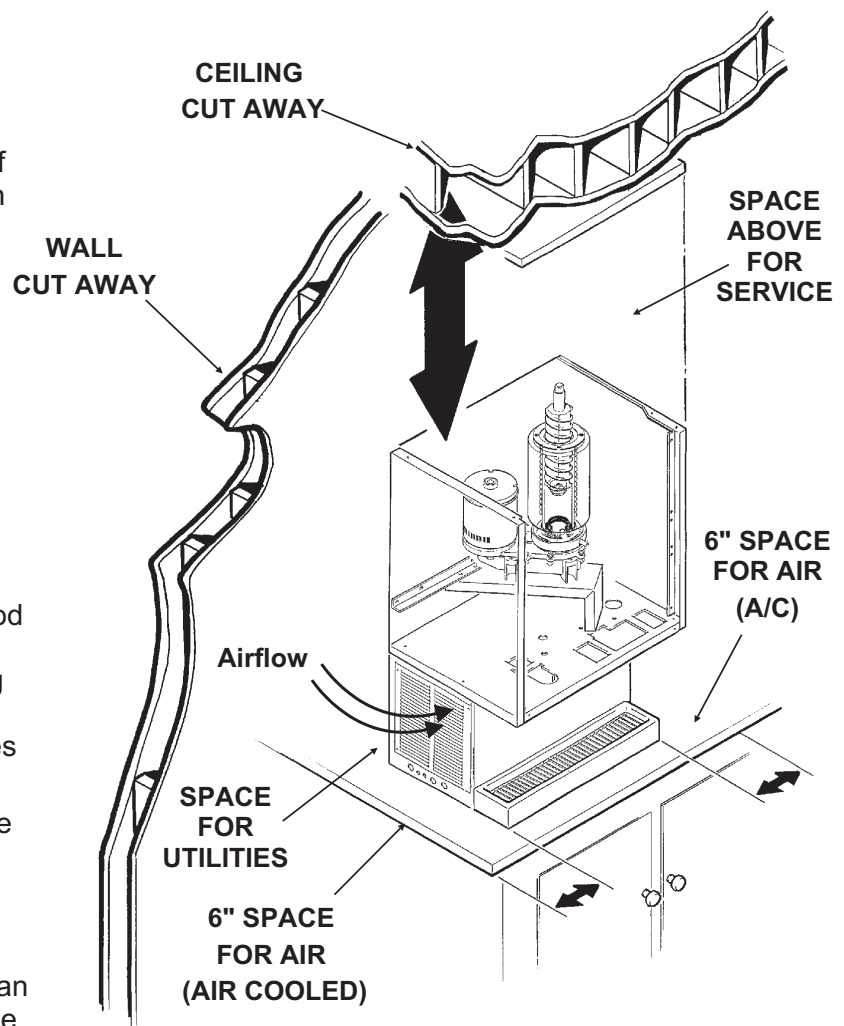

MDT5N25 & MDT5N40

FOR THE INSTALLER

Location

After uncrating and inspection, the unit is ready for installation. It is important that the machine be installed in a location where it has enough space above and behind it for service. Air cooled models require a minimum of 6 inches to the left and right of the machine for air circulation.

Machine Stand Installation

Tip the stand on its back and install the legs, return the stand to the upright position. Adjust leg levelers so that the stand does not "rock".

Counter Top or Machine Stand Installation

The base of the icemaker-dispenser must be sealed to the object it rests upon. Food grade silastic sealant such as Scotsman part number 19-0529-01 is recommended.

Place a bead of the sealant on the machine stand or counter top to match the outside edge of the cabinet base and sink.

The icemaker-dispenser is heavy: use of a mechanical hoist is recommended to lift it to the height required to install it.

The DMS machine stand has holes in the top that match up with threaded holes in the icemaker-dispenser. Place the cabinet onto the machine stand, so that the unit is lined up with the holes. Secure the ice maker-dispenser to the machine stand with bolts and washers.

In both counter top and machine stand installations, wipe off and neatly smooth any excess sealant. Level the machine stand and cabinet.

Unpack and install the sink brackets. Fit the sink assembly onto the two sink brackets, and press onto the bead of sealant. Wipe off and neatly smooth any excess sealant from under the sink edge.

Unpack and install the ice and water spouts.

Ice Spout: Slide up and over ice outlet. No fastener is required to hold it in place.

Water Spout: Slide over stainless steel water discharge tube, locate and match up with notches in the base. Rotate clockwise to move spout into installed position.

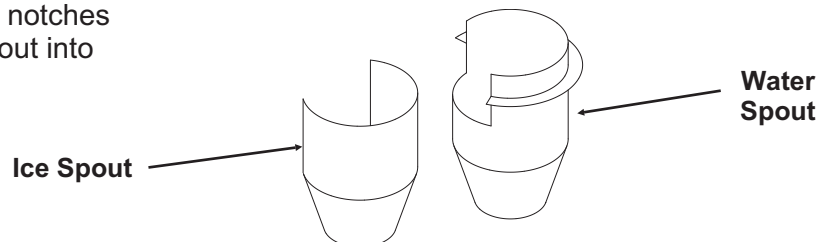
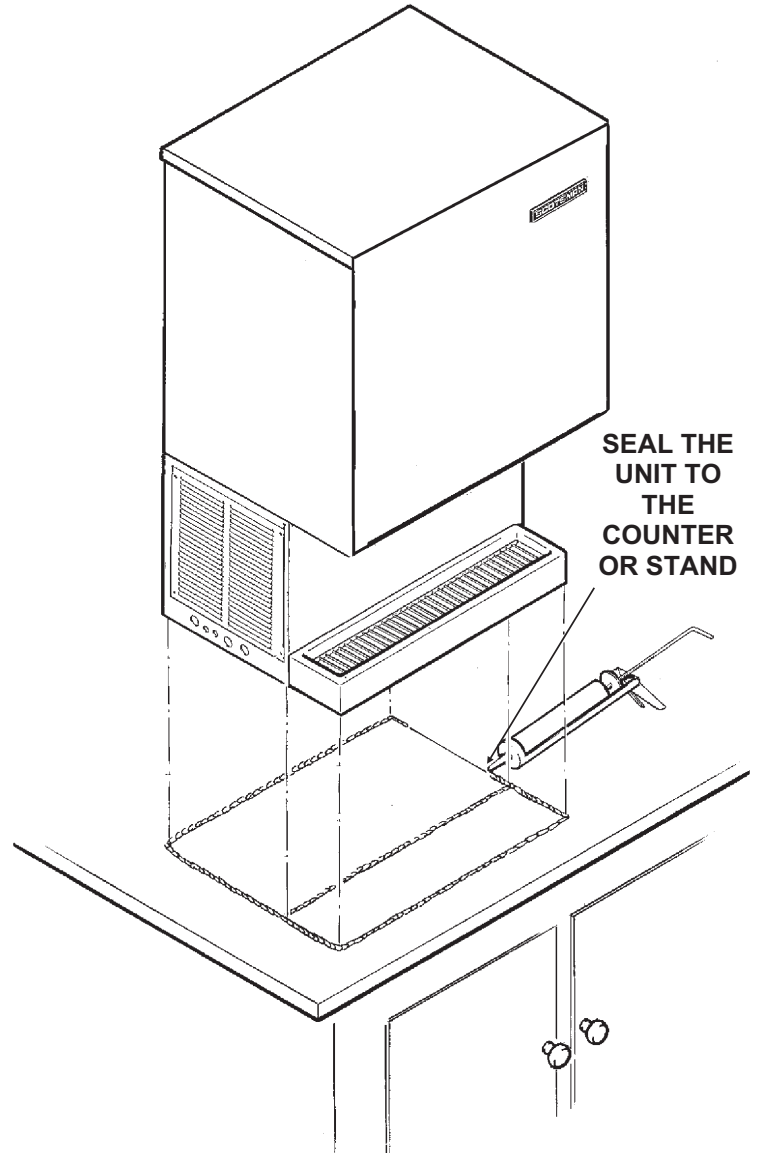

MDT5N25 & MDT5N40

FOR THE INSTALLER: Wall Mount Kit

CAUTION

It is recommended that the wall mounting installation be done by an experienced contractor. The weight of the machine when in use may exceed 350 pounds. The unit should be mounted on a solid, rigid wall with proper fasteners for that type of wall and of adequate strength to support the weight of the machine when in use.

Clearance between the wall and the icemaker is a maximum of 1 inch. Check utility connections first. The electrical junction box will have to be removed, and the electrical connections made inside the cabinet in compliance with local codes. The plumbing connections may be made through the base, or at either side through the pre-punched holes, using standard plumbing practices.

Interior plumbing lines must be disconnected from the original connections and plugged when routing through the side or base.

1. Remove machine top. Attach bracket "A" to machine using (3) nuts, (3) flat washers, (3) lock washers, and (3) 5/16-18 bolts received with the kit.

MDT6N40=38.6"

MDT6N25=30"

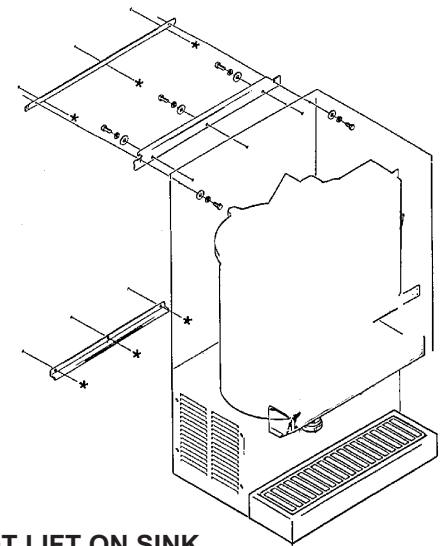
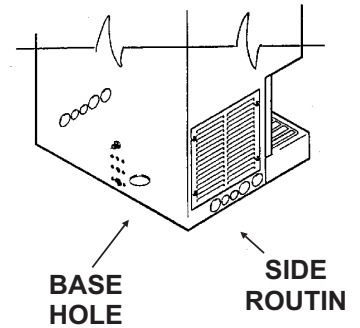
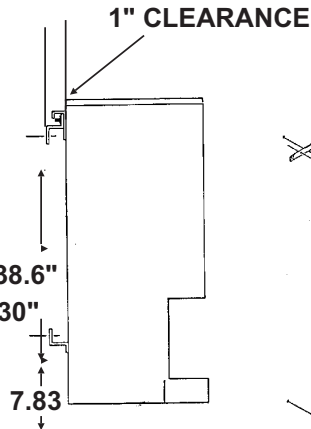

DO NOT LIFT ON SINK

2. Mount brackets "B" and "C" to the wall at the dimensions shown for the unit. (hardware for this is not included).

Use fasteners and wall of sufficient strength to carry the use and weight of the icemaker-dispenser.

3. Lift unit up and hook bracket "A" over bracket "B". Slide unit until the two remaining holes are aligned and secure with the remaining (2) 1/4-20 bolts, flat washers and lock washers.

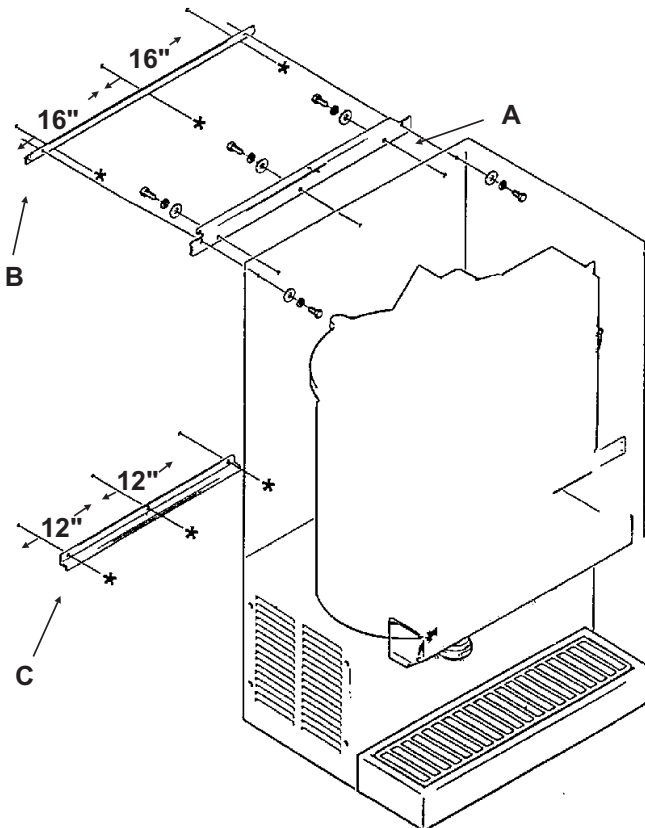

MDT5N25 & MDT5N40

FOR THE PLUMBER

CONFORM TO ALL APPLICABLE CODES

Water Inlet

Air Cooled Models: The recommended water supply is clean, cold water. Use 3/8" O.D. copper tubing, connect to the 3/8" male flare at the back of the cabinet. Install a hand valve near the machine to control the water supply.

Water Treatment: In most areas, a water filter of some type will be useful. In areas where the water is highly concentrated with minerals the water should be tested by a water treatment specialist, and the recommendations of the specialist regarding filtration and/or treatment should be followed.

Water Cooled Models: A separate 3/8" O.D. copper line is recommended, with a separate hand valve to control it. It is connected to a 3/8" FPT condenser inlet at the back of the cabinet. The water pressure to all lines must always be above 20 psig, and below 80 psig.

Drains

Air Cooled Models: There is one 3/4" FPT drain at the back of the cabinet, the drain line is of the gravity type, and 1/4 inch per foot fall is an acceptable pitch for the drain tubing. There should be a vent at the highest point of the drain line, and the ideal drain receptacle would be a trapped and vented floor drain. Use only 3/4" rigid tubing.

Water Cooled Models: In addition to the above mentioned drain, a separate condenser drain must be installed. Connect it to the 1/2" condenser drain connection at the back of the cabinet.

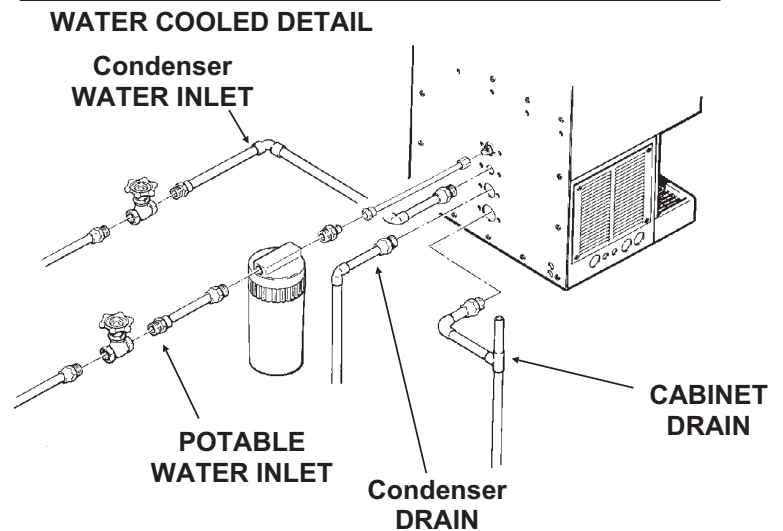
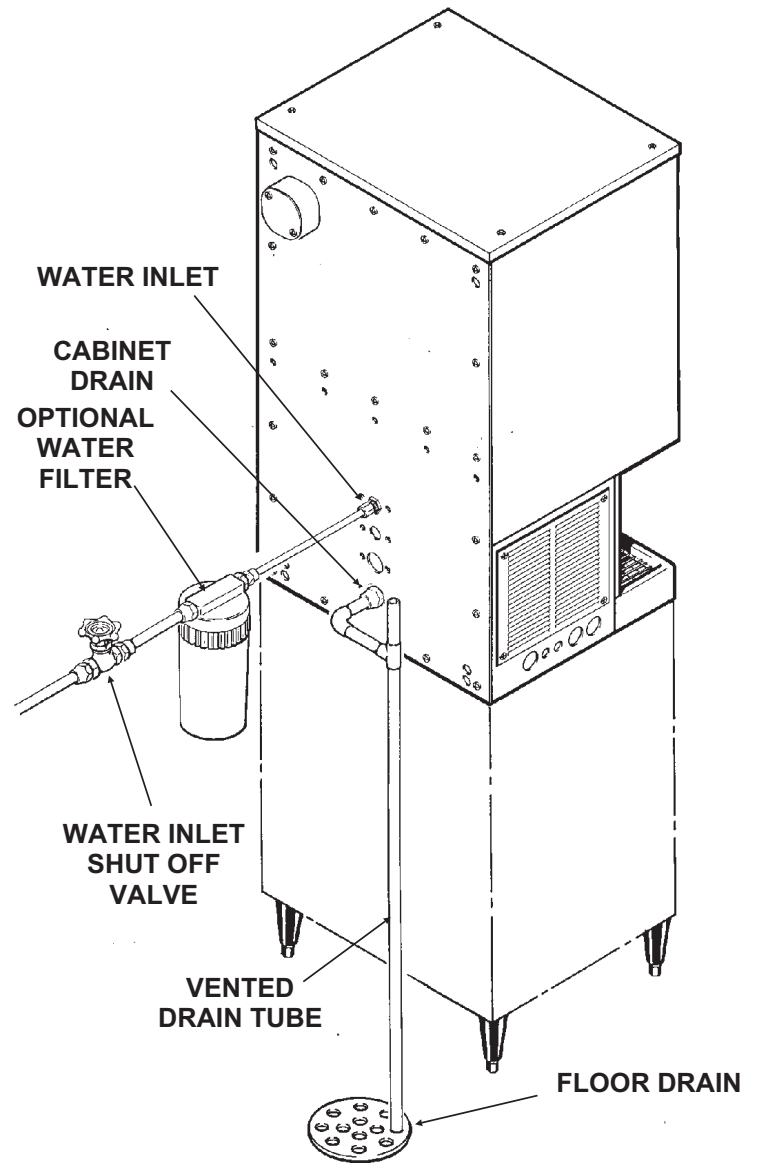

FOR THE ELECTRICIAN

CONFORM TO ALL APPLICABLE CODES

The electrical power to the unit is supplied through the junction box at the rear of the machine.

Check the nameplate (located on the back panel) for the voltage requirements, and for the minimum circuit ampacity. The machine requires a solid chassis to earth ground wire.

The ice maker should be connected to its own electrical circuit so it would be individually fused. Voltage variation must remain within design limitations, even under starting conditions.

All external wiring must conform to national, state, and local electrical codes. The use of a licensed electrician is required to perform the electrical installation.

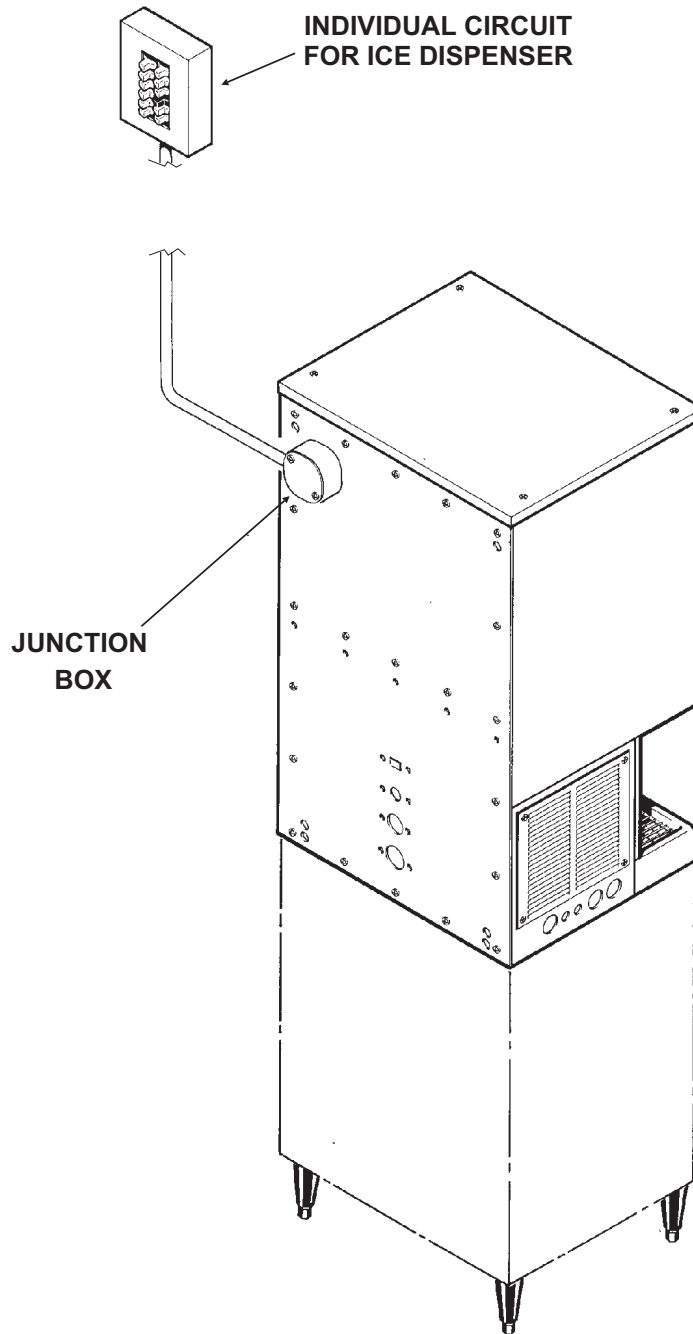

MDT5N25 & MDT5N40

FOR THE INSTALLER: Final Check List

1. Is the icemaker-dispenser installed indoors, in a location where the air and water temperatures are controlled, and where they do not go beyond design limitations?

2. Is there an electrical disconnect (switch or plug as required) within sight of the installed machine? Is the machine on a separate circuit? Has the voltage been checked and compared to nameplate requirements?

3. Have all of the plumbing connections been made and checked for leaks?

4. Has the machine been leveled?

5. Is there a minimum of 6 inches of clearance at the left and right sides of an air cooled machine?

6. Is there a minimum of 6 inches of clearance at the top and back of the machine for service and utility connections?

Wall mounted only: Is the machine properly installed and secured to the wall?

7. Is there a water shut off valve installed near the machine?

BACK VIEW OF COMPLETED INSTALLATION

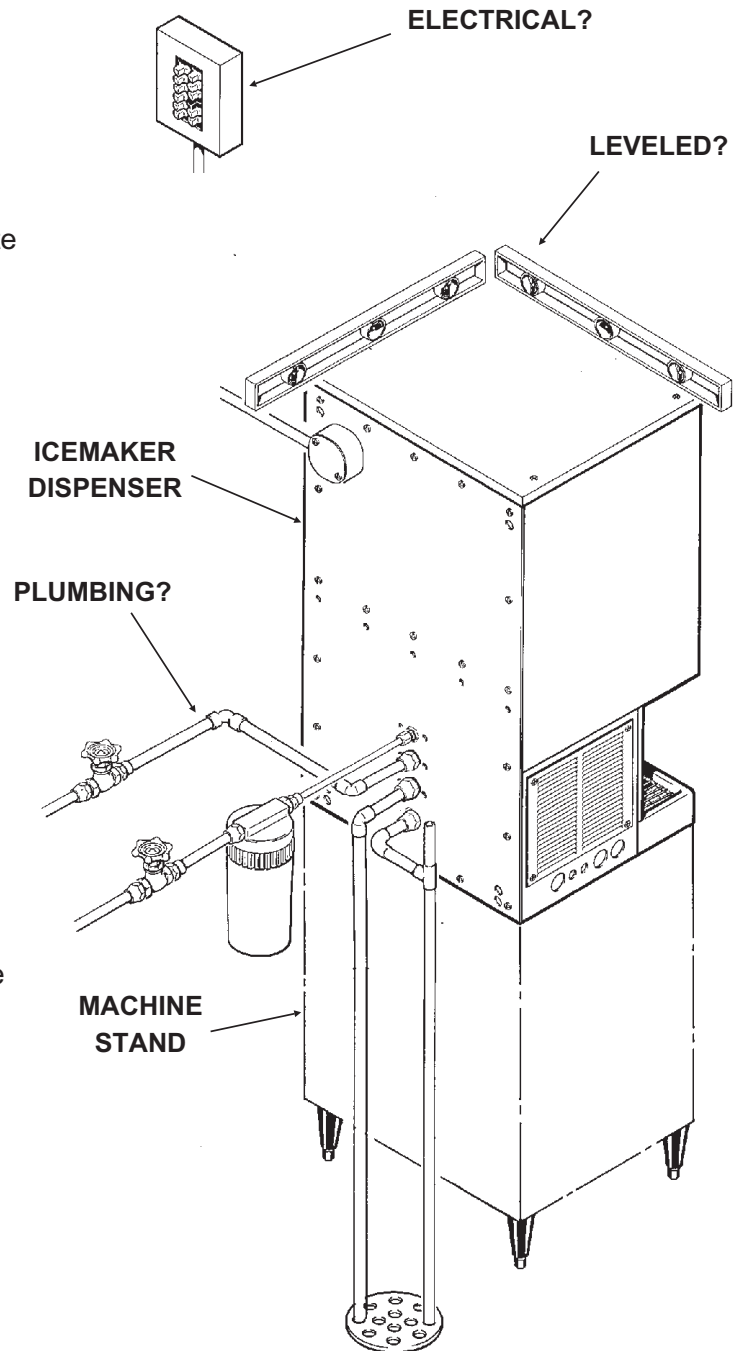

INITIAL START UP

Pre Start Inspection

1. Remove the two front panels.
2. Check that all shipping blocks have been removed.
3. Remove any and all packing tape (check inside the storage bin).
4. Inspect the interior of the machine for loose screws or wires. Check that no refrigerant lines are rubbing each other. Check that the fan blade on air cooled models turns freely.
5. Check that the machine is installed correctly according to the final check list.

Start Up

1. Go through the pre start inspection.
2. Open the water hand valve, observe that water enters the water reservoir, fills the tube from the reservoir to the evaporator and then shuts off. Check for leaks.
3. Switch the master switch on. The electrical start up sequence is automatic; there will be a short (15 second) delay before the machine starts.
4. On air cooled models, warm air will begin to flow from the condenser. Water cooled models will begin to discharge warm water down the drain.
5. The unit should soon be making ice. If desired, the low side pressure may be checked: it should be 38 PSIG + or - 2 PSIG.
The air cooled discharge pressure will depend upon air and water temperatures, but should be between 240 PSIG and 340 PSIG.
Water cooled discharge pressure should be about 245 PSIG. If needed, adjust the water regulating valve.
The above numbers are for new, clean machines. Field values may be somewhat higher or lower.
6. There are no adjustments to make, so replace the panels.
7. Check ice dispensing by holding a container in front of the Touch Free ice sensor (just below the ice delivery spout). Ice should flow from the spout when a container is present, and stop dispensing when the container is removed.
8. Switch off the icemaker-dispenser, remove the top panel and the top of the ice storage bin. Sanitize the interior of the ice storage bin by wiping it with a mixture of 1 ounce of household bleach to 2 gallons of water, allow to air dry. Replace all covers and panels. Switch the icemaker-dispenser back on.
9. Give the owner/user the service manual, instruct him/her in the operation and maintenance requirements of the unit. Make sure they know who to call for service.
10. Fill out the Customer Evaluation and Warranty Registration form, and mail it in to Scotsman.

MDT5N25 & MDT5N40

COMPONENT DESCRIPTION

High Pressure Cut Out Switch: A manual reset switch sensing the high side refrigeration pressure. It is set to shut the machine off if the discharge pressure should ever exceed 450 psig.

Evaporator: A vertical stainless steel tube, refrigerated, and water filled. In it there is a stainless steel auger.

Reservoir: Float operated, it maintains the water level in the evaporator at a constant level, it also contains the water level sensor.

Water Level Sensor: Senses if there is water in the reservoir to make ice out of. Will shut the machine off if there is none.

Ice Level Sensor: An electronic "eye", it senses the presence of ice in the bottom of the ice discharge chute. Operates to turn the ice machine on and off automatically as the level of ice in the bin changes.

Drain Tube: When uncapped and lowered, drains the evaporator.

Condenser: Air or water cooled, where the heat removed in ice making is discharged.

Ice Storage Bin Assembly: A plastic lined, insulated cylinder that receives, stores and dispenses the ice. Fresh ice enters at the top, and when the bin is full enough the ice will be between the ice level sensors, and the ice making will stop. Ice is dispensed through a chute at the bottom front when the bin vane sweeps the ice over the chute.

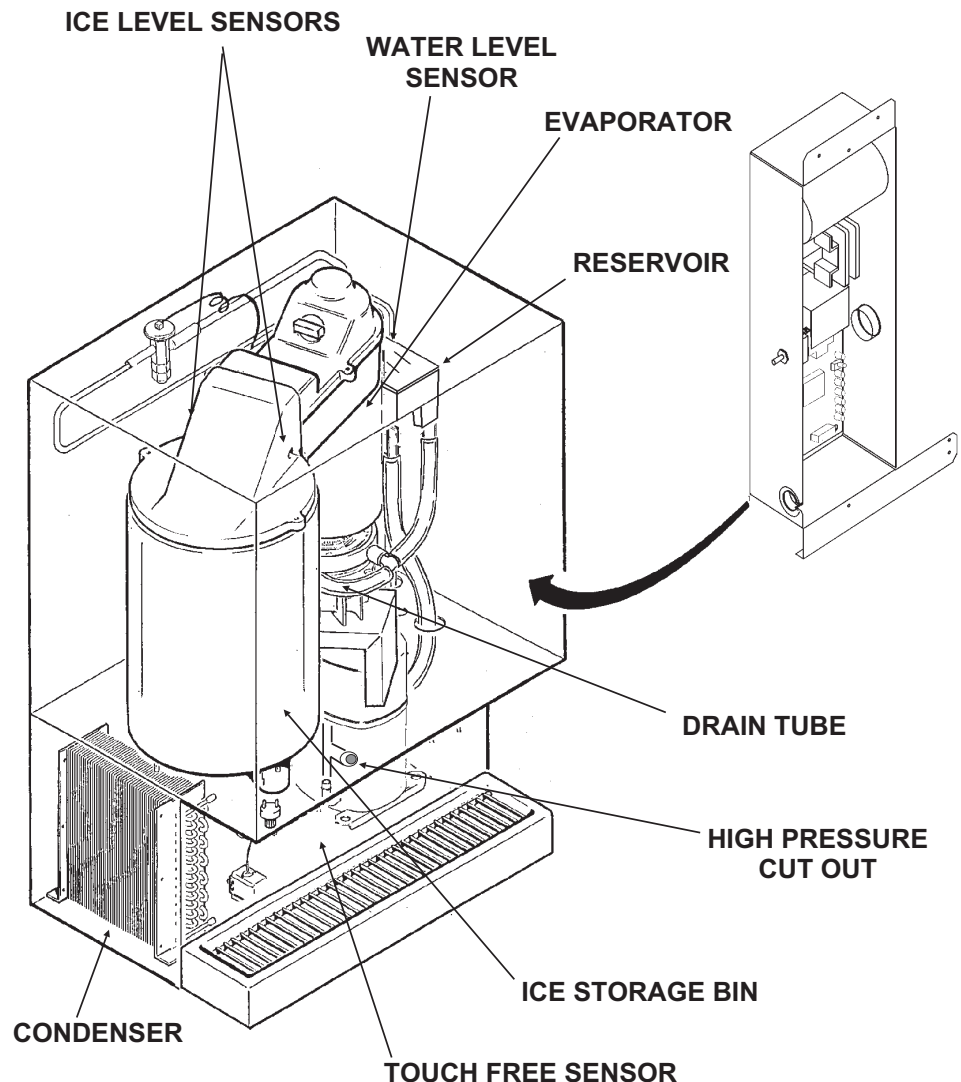

COMPONENT DESCRIPTION

Evaporator: A refrigerated vertical tube filled with water and containing a water seal and auger.

Auger: A solid stainless steel double spiral auger, it pushes the ice crystals up to the top of the evaporator.

Water Seal: A two part "face" seal, the top half rotating with the auger, the bottom half stationary, the sealing action being where the two seal "faces" meet.

Ice Sweep: A plastic cap with "fingers". It revolves with the auger to "sweep" the ice into the ice chute.

Breaker: Where the ice is compressed and much of the extra water is squeezed out of it before it is discharged into the bin.

Motor: A split phase motor that drives the gear reducer.

Thrust Bearing: As the ice is pushed up the evaporator, the auger is thrust down, and pressure from the auger thrust is taken up by this bearing.

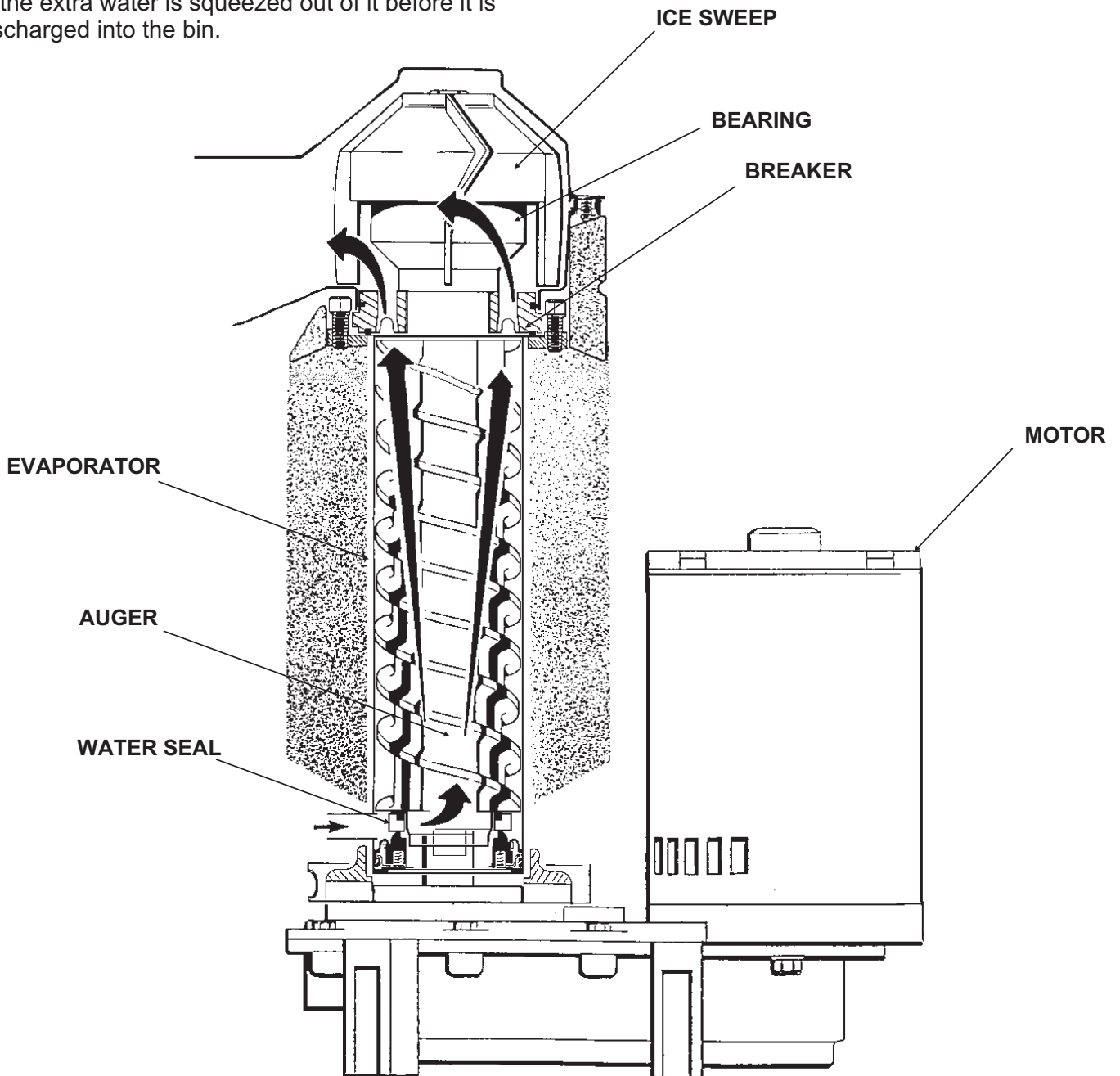

MDT5N25 & MDT5N40

COMPONENT DESCRIPTION: Control Box

Circuit Board:

The circuit board receives input signals from several sensors and translates them to control the electrical power supply to the various loads.

The sensors include:

- Touch Free ice or water.
- Ice level in the bin.
- Water level in the reservoir.

The loads include:

- Compressor contactor
- Fan motor
- Bin drive motor
- Auger drive motor
- Water solenoid.

In addition, a "Clean" switch is available to temporarily disable the Touch-Free sensors for cleaning of the splash panel.

On/Off Switch: Manual control for the machine.

Contactors: A definite purpose contactor connecting the compressor to the power supply.

Potential Relay: The compressor start relay.

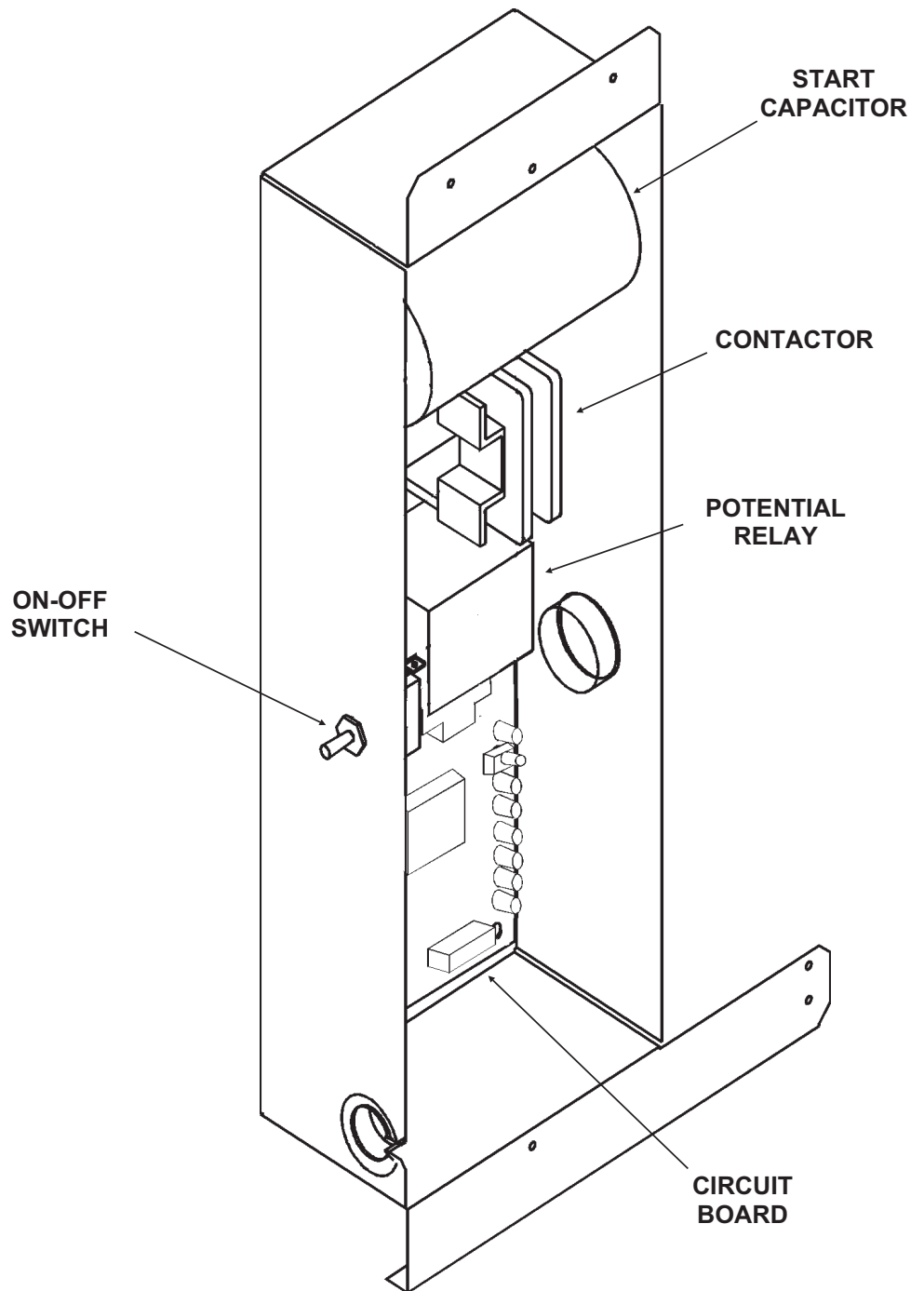

ELECTRICAL SEQUENCE

Refer the wiring diagram as needed.

The “Power” light on the board glows whenever there is power to the machine (and the master switch is ON).

If the machine is switched off at the master switch, but is otherwise ready to go, switching the master switch to ON does the following:

- The bin empty and power lights on the circuit board glow.
- There is a 15 second delay
- If there is enough water in the reservoir, the circuit board will allow the machine to start up.

Start up consists of:

- The compressor contactor coil receives power from the circuit board.
- The contactor is energized, connecting power to the compressor, and the compressor starts.
- The auger motor receives power from the circuit board and starts.
- As ice goes past the ice level sensors, the bin empty light will stay on and the machine will continue to run, unless the ice stays between the sensors for more than 15 seconds (bin full). At that point, the bin empty light goes out, and the machine shuts down.

Other reasons for shut down:

- Low water level (as sensed by the thermistor in the reservoir).

Shut Down consists of:

- The compressor contactor opens
- The compressor stops
- The auger motor is run by the circuit board for 2 more minutes, clearing out ice in the evaporator, and then
- The auger motor no longer receives power from the circuit board, and the auger motor stops.

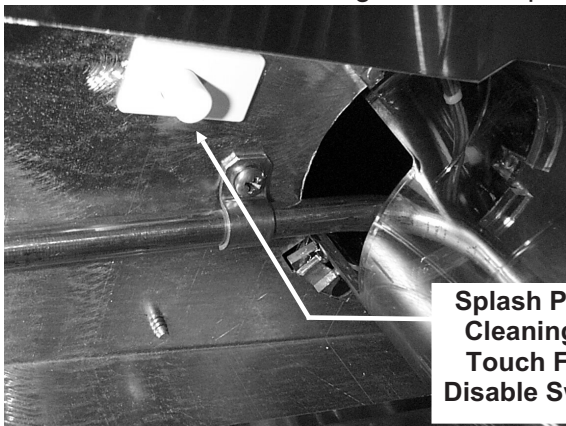

**Splash Panel
Cleaning or
Touch Free
Disable Switch**

After a 6 minute delay, If the ice level sensor is clear (bin empty) for more than 15 seconds, the machine will start up again.

Another purpose of the circuit board is to turn the machine off if there is not enough water in the machine.

- When the water level in the reservoir falls below the tip of the water level sensor, the machine will “shut down”
- After a 6 minute delay, if the water refills the reservoir, the machine will start up again.

Separate from the circuit board:

- If the high pressure control (cut out switch) opens, the compressor will stop immediately (through the contactor). It must be manually reset.
- The master switch is the manual control for the complete machine, but it is not a service disconnect.

Ice Vending

- When a user places a container in front of the Touch Free ice sensor and below the ice delivery chute, the circuit board connects power to the bin drive motor and ice is dispensed for as long as the container is present. If the user does not remove the container, ice will be dispensed for 60 seconds and then stop.
- When a user places a container in front of the Touch Free water sensor, and below the water spout, the circuit board connects power to the water solenoid valve and water is dispensed. If the user does not remove the container water will be dispensed for 90 seconds and then stop.

Splash panel cleaning:

- A switch, located next to the water spout, may be pushed to disable the Touch-Free sensors for splash panel cleaning. It automatically resets after 2 minutes, or, if pushed within the 2 minutes, resets the circuit board to enable the Touch Free sensors.

MDT5N25 & MDT5N40

OPERATION: Water

Water enters the machine through the 3/8" male flare at the rear of the cabinet, goes to a strainer and then to the water reservoir which it enters through the float valve. The water then goes out the bottom of the reservoir tank to the bottom of the evaporator.

Reservoir overflow, evaporator condensation and water in the sink are all routed to the drain. Water cooled models have a separate water circuit for the cooling water: it enters the fitting at the rear, goes to the water regulating valve, then to the water cooled condenser and down the drain.

There is also an additional water circuit to an electric valve. When the Touch Free system senses a container for water, it closes a circuit to the electric water valve, and water is dispensed.

Note: The correct water level is determined when the machine is operating. Check the water level and compare it to the line molded into the side of the reservoir. The water level should be between / " above and / " below the line.

If needed, adjust the water level by bending the float arm.

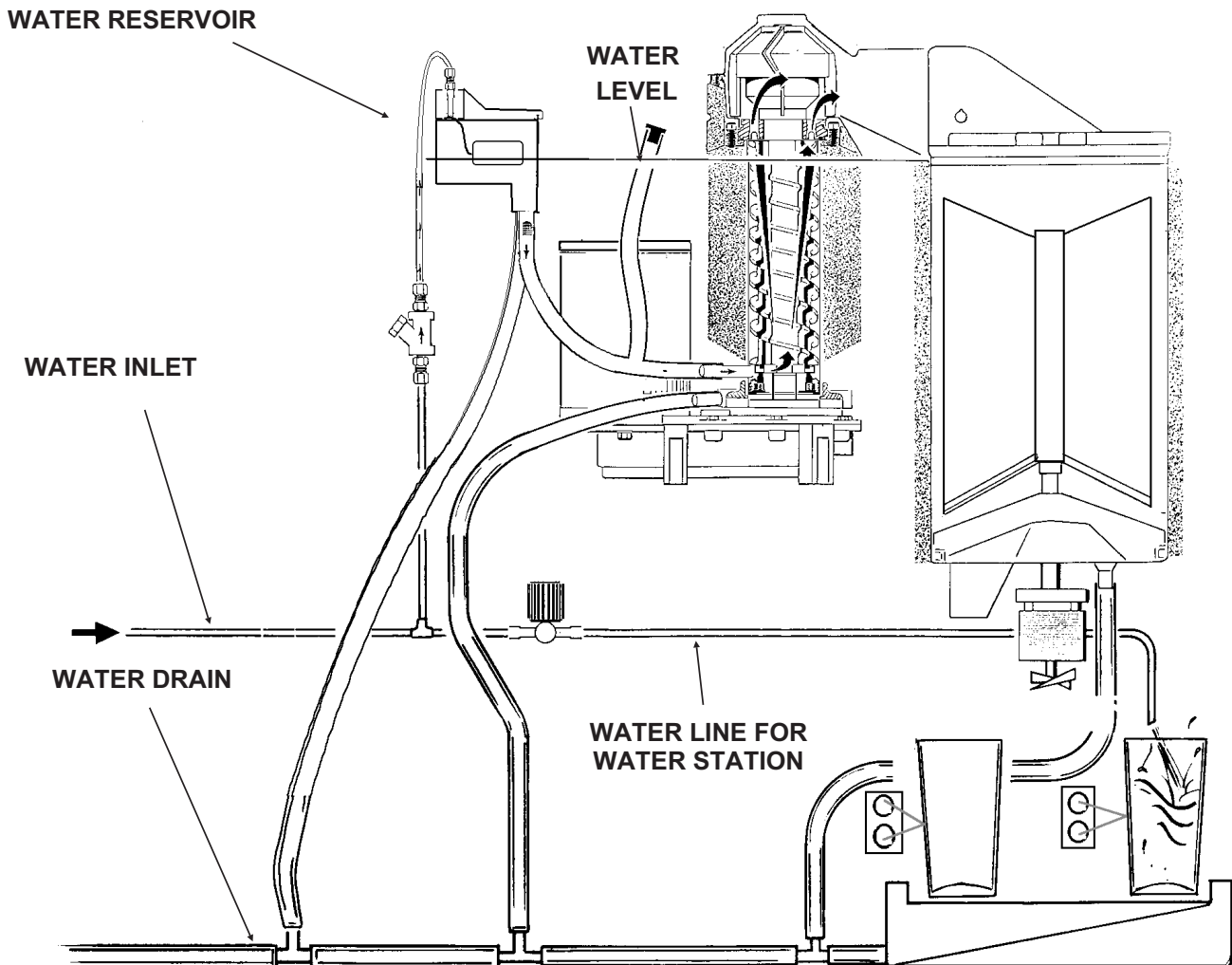

OPERATION: Refrigeration

Beginning at the compressor, the refrigerant is compressed into a high temperature gas. The discharge line directs this gas to the condenser. At the condenser (air or water cooled) the gas is cooled by either air or water and it then condenses into a liquid. This high pressure liquid then goes through the liquid line to the expansion valve.

The thermostatic expansion valve meters liquid refrigerant into the evaporator, the volume of liquid refrigerant depending upon the temperature of the evaporator; warmer evaporators get more refrigerant and colder evaporators get less.

At the evaporator, the refrigerant enters an area of relatively low pressure, where it can easily "boil off" or evaporate. As it evaporates, it absorbs heat from the evaporator and whatever is in contact with it (such as the water inside it). After the evaporator, the refrigerant, now a low pressure vapor, goes through the suction line back to compressor, where the cycle is repeated.

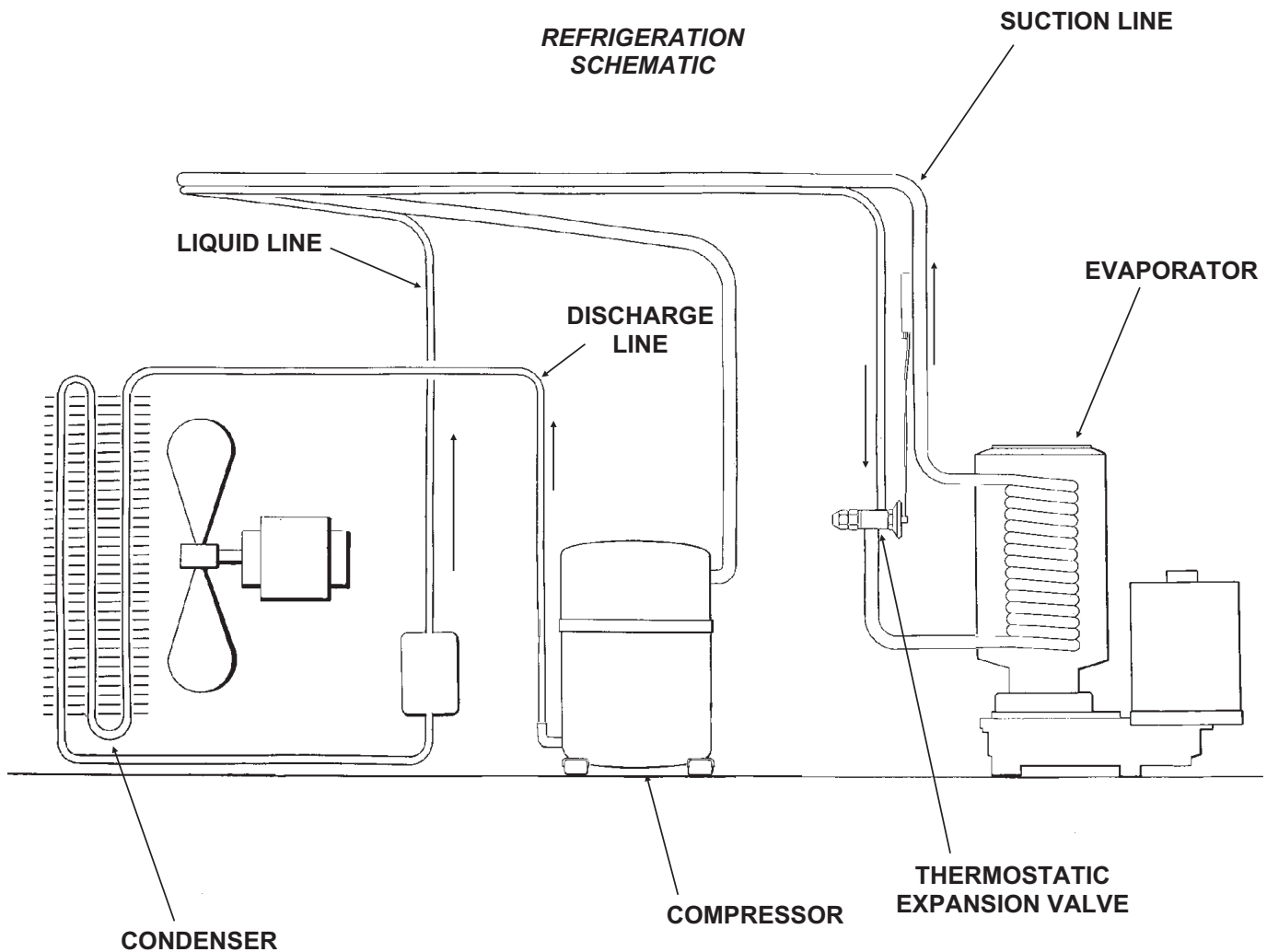

MDT5N25 & MDT5N40

OPERATION: Ice Vending

Dispensing takes place when the Touch Free sensor's infrared beam bounces back to the sensor from a container placed directly in front of it.

If the container is in front of the Touch Free sensor on the left side, the ice dispensing vane will rotate and sweep ice over the ice dispensing chute: ice will continue to discharge out this chute as long as the vane is turning. It stops when the dispensing vane stops.

If the container is in front of the Touch Free sensor on the right side, the inlet water valve will open and water will flow into the container.

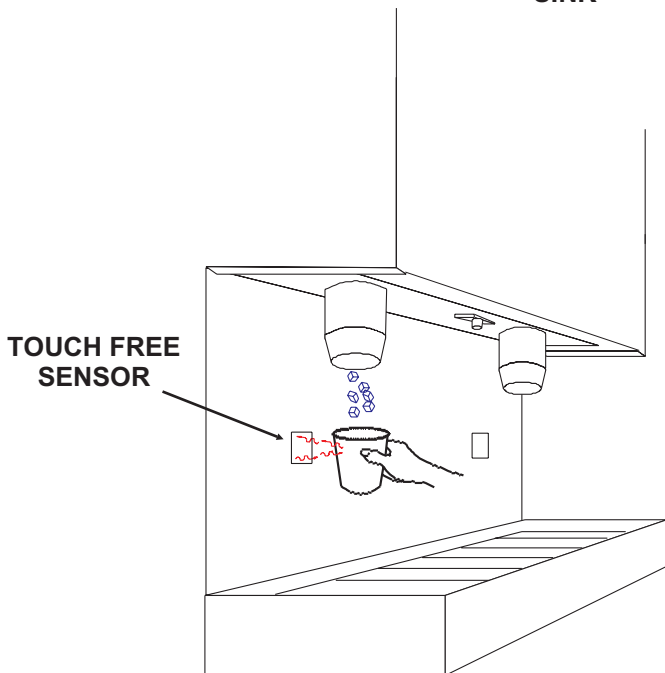
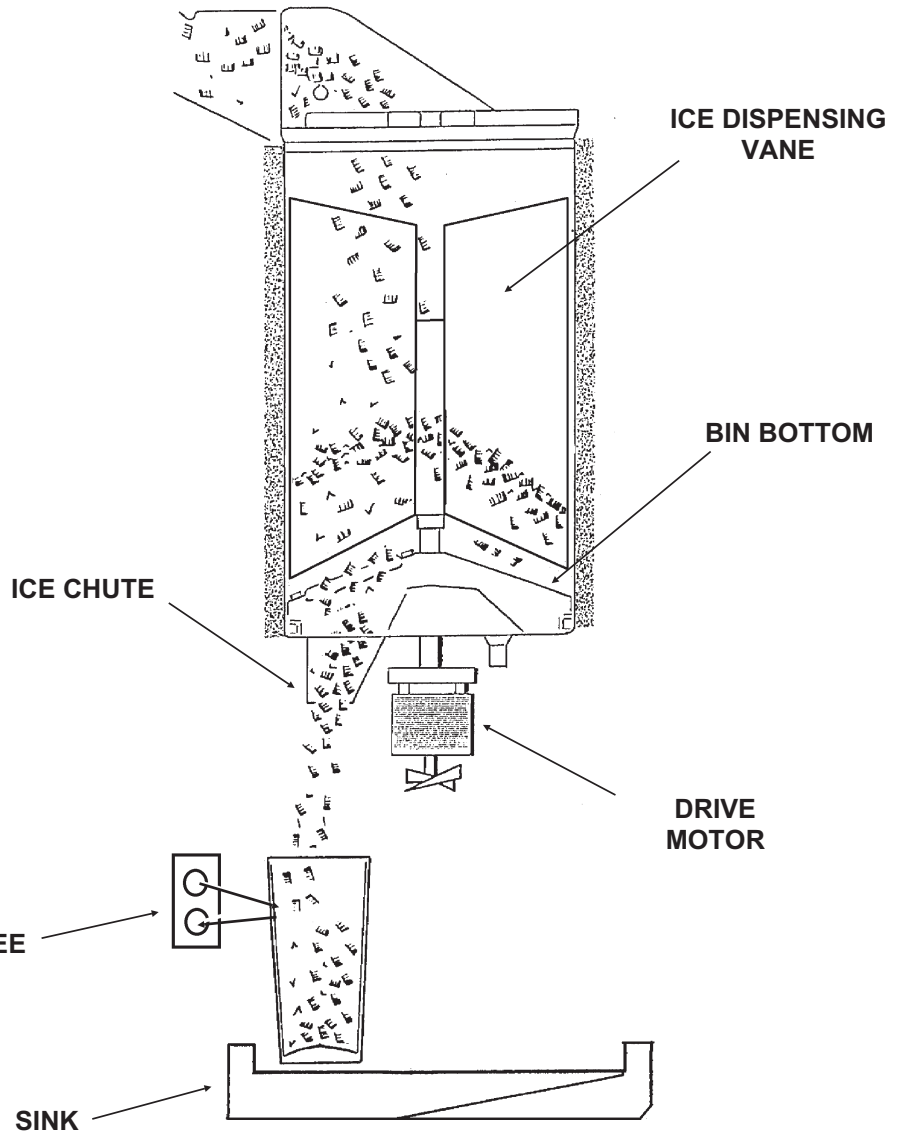

The Touch Free System:
Hold or Place a Container in Front
of The Touch Free Sensor & Under
The Ice or Water Spout;
Ice or Water Will Be Dispensed
Without Touching The Dispenser

DISPENSE AREA SANITATION

The dispense area; spouts, sink, grill and splash panel will need periodic cleaning and maintenance.

1. The ice chute may be pulled down to remove it from the ice dispenser. Wash and sanitize it.
2. The sink grill may be removed for washing and sanitizing.
3. The sink should be flushed with hot water and wiped clean with sanitizer.
4. The splash panel requires special attention to clean it.
 - Push and release the Splash Panel Cleaning switch located to the left of the water spout. This disables the Touch Free sensors so the splash panel may be cleaned without vending ice and/or water.
 - Wash the splash panel and wipe with with sanitizer.
 - Re-push the clean switch or allow 2 minutes to pass for the Touch Free system to reset.

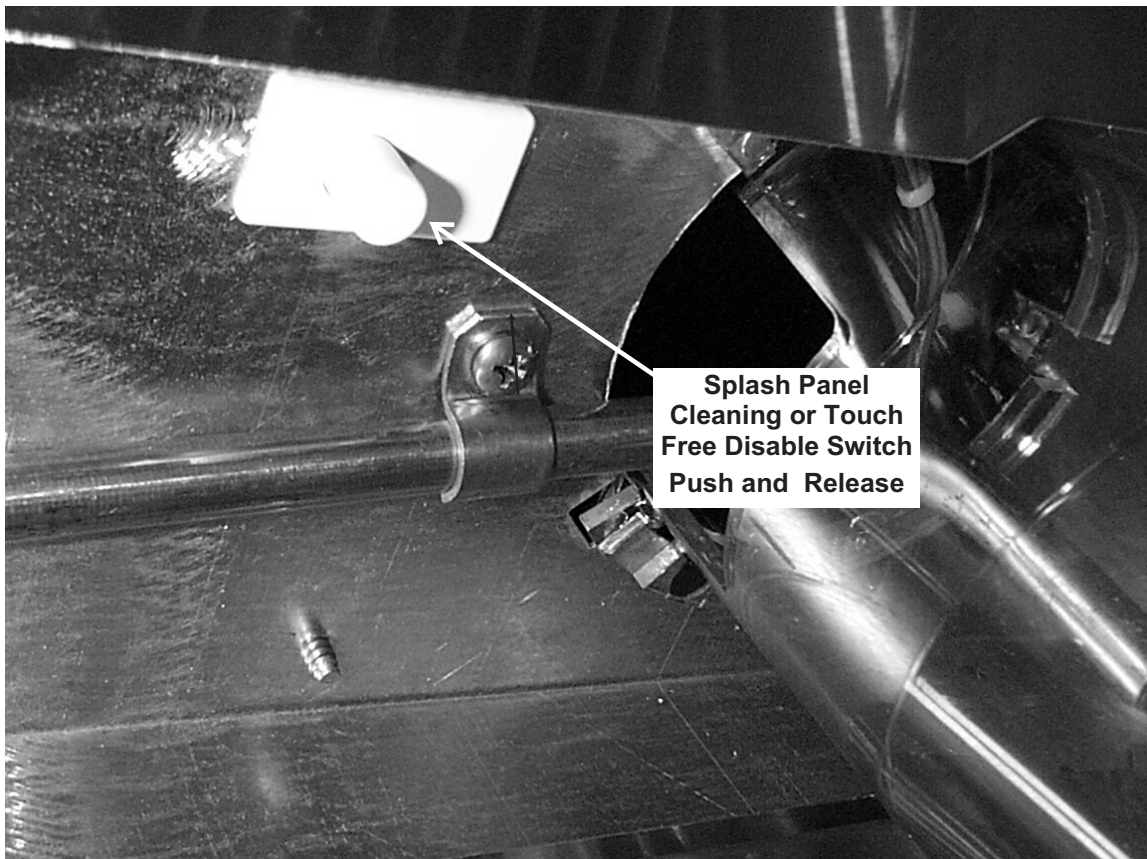

MDT5N25 & MDT5N40

CLEANING and SANITIZING

A Scotsman Ice System represents a sizable investment of time and money in any company's business. In order to receive the best return for that investment, it **MUST** receive periodic maintenance.

It is the **USER'S RESPONSIBILITY** to see that the unit is properly maintained. It is always preferable, and less costly in the long run, to avoid possible down time by keeping it clean; adjusting it as needed; and by replacing worn parts before they can cause failure. The following is a list of recommended maintenance that will help keep the machine running with a minimum of problems.

Maintenance and Cleaning should be scheduled at a **minimum of twice per year**.

Sanitizing of the ice storage bin should be scheduled for a minimum of 4 times a year.

Electrical power will be ON when doing in place cleaning.

ICEMAKING SYSTEM: In place cleaning

1. Check and clean any water treatment devices, if any are installed.
2. Remove screws and remove the upper front panel.
3. Move the ON-OFF switch to OFF.
4. Remove the cover to the ice storage bin, and remove the ice.
5. Remove the cover to the water reservoir and block the float up.
6. Drain the water reservoir and freezer assembly using the drain tube attached to the freezer water inlet. Return the drain tube to its normal upright position and replace the end cap.
7. Prepare the cleaning solution: Mix eight ounces of Scotsman Ice Machine Cleaner with three quarts of hot water. The water should be between 90-115 degrees F.

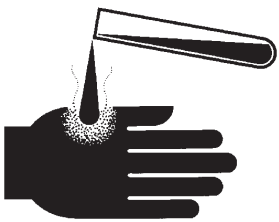
<p>Scotsman Ice Machine Cleaner contains acids.</p> <p>These compounds may cause burns. If swallowed, DO NOT induce vomiting. Give large amounts of water or milk. Call Physician immediately. In case of external contact, flush with water. Keep out of the reach of children.</p>	<p>⚠ WARNING</p> 
--	---

8. Slowly pour the cleaning solution into the water reservoir until it is full. Wait 15 minutes, then switch the master switch to ON.

9. As the ice maker begins to use water from the reservoir, continue to add more cleaning solution to maintain a full reservoir.

10. After all of the cleaning solution has been added to the reservoir, and the reservoir is nearly empty, switch the master switch to OFF.

11. After draining the reservoir, as in step 6, wash and rinse the water reservoir.

To Sanitize:

Repeat steps 8-11, only use an approved sanitizing solution in place of the cleaning solution. A possible sanitizing solution to use could be 1 ounce of household bleach mixed with 2 gallons of warm (95°F. - 115°F.) water.

12. Remove the block from the float in the water reservoir.

13. Switch the master switch to ON

14. Continue ice making for at least 15 minutes, to flush out any cleaning solution. Check ice for acid taste - continue icemaking until ice tastes sweet.

DO NOT USE any ice produced from the cleaning solution.

Be sure no ice remains in the bin.

15. Remove all ice from the storage bin.

16. Add warm water to the ice storage bin and thoroughly wash and rinse all surfaces within the bin.

17. Sanitize the bin cover, dispensing vane, bin bottom, and interior with an approved sanitizer using the directions for that sanitizer.

18. Replace the ice storage bin cover, and the front panel.

MAINTENANCE AND CLEANING

	<h3>⚠ WARNING</h3>
	<p>Moving Parts Hazard. Disconnect electrical power to the icemaker - dispenser before beginning.</p>

1. Air Cooled Models: Check the air cooled condenser for lint, dirt or grease build-up. Clean with vacuum or soft brush until light can be seen thru the fins.

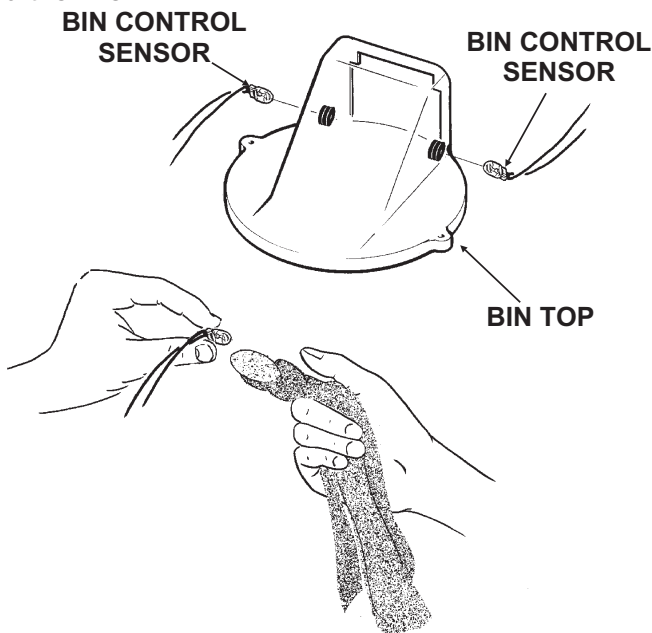

2. The ice machine senses water level by a probe located in the water reservoir. At least twice a year, the probe should be removed from the reservoir, and the tip wiped clean of mineral build-up.

3. The bin control uses devices that sense light, therefore they must be kept clean enough so that they can "see". At least twice a year, remove the bin control sensors from the grommets in the ice chute, and wipe them clean.

4. The bearing in the breaker should also be checked at least **two times per year**.

A. Check the bearing by:

- removing the ice chute cover
- unscrewing the ice sweep
- removing the water shed
- unscrewing the breaker cover.
- unscrewing the auger stud

Inspect the assembly, looking for wear.

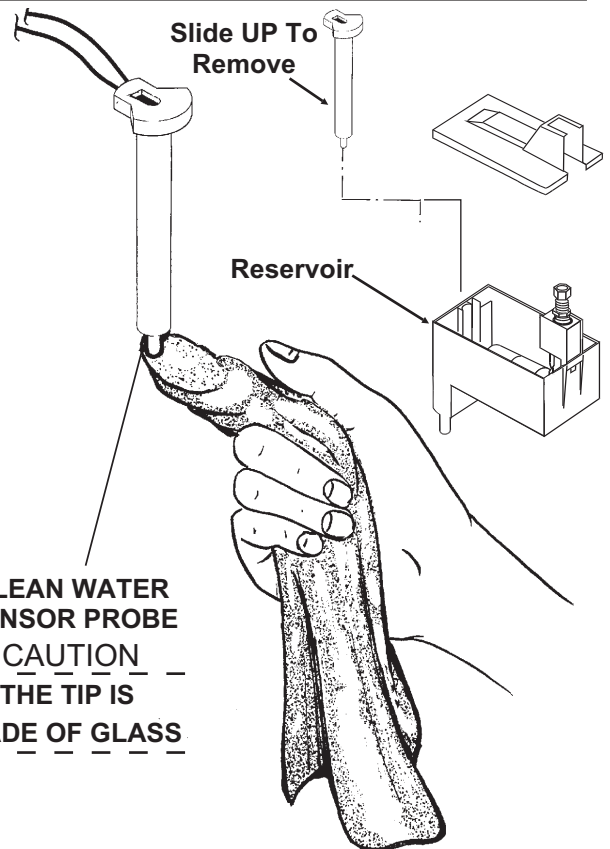

See Removal and Replacement to replace bearing or seals. Reverse to reassemble.

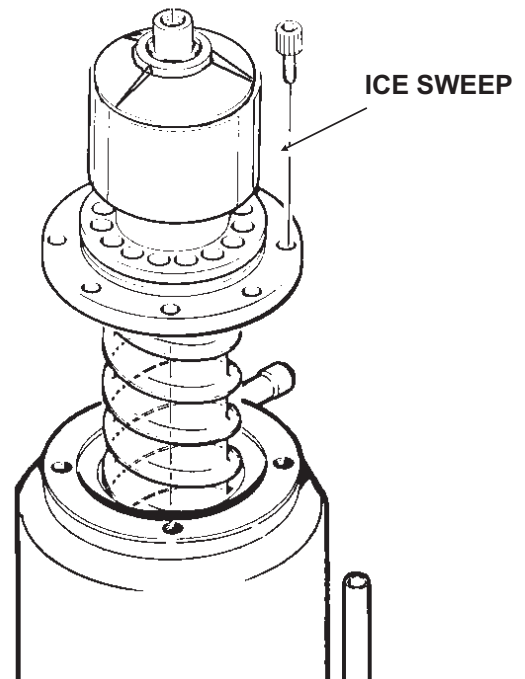

5. Check and tighten all bolts and screws.

MDT5N25 & MDT5N40

MAINTENANCE AND CLEANING

In some areas, the water supply to the ice maker will contain a high concentration of minerals, and that will result in an evaporator and auger becoming coated with these minerals, requiring a more frequent removal than twice per year. If in doubt about the condition of the evaporator and auger, the auger can be removed so the parts can be inspected.

	⚠ WARNING
	Moving Parts Hazard. Disconnect electrical power to the icemaker - dispenser before beginning.

Note: Water filters can filter out suspended solids, but not dissolved solids. "Soft" water may not be the complete answer. Check with a water treatment specialist regarding water treatment.

For more information on removal of these parts, see REMOVAL AND REPLACEMENT.

1. To remove the auger, remove the front and top panels.
2. Push bail clamp off of cover and remove cover.
3. Unscrew and remove ice sweep.
4. Remove ice chute from evaporator.
5. Remove 4 allen screws holding breaker to evaporator.
6. Pull up to remove auger.

After the auger has been removed, allow the auger to dry: if the auger is not bright and shiny, it must be cleaned.

Clean the auger and evaporator as required. **DO NOT HONE THE EVAPORATOR.**

7. Replace the water seal.
8. Reverse to reassemble.

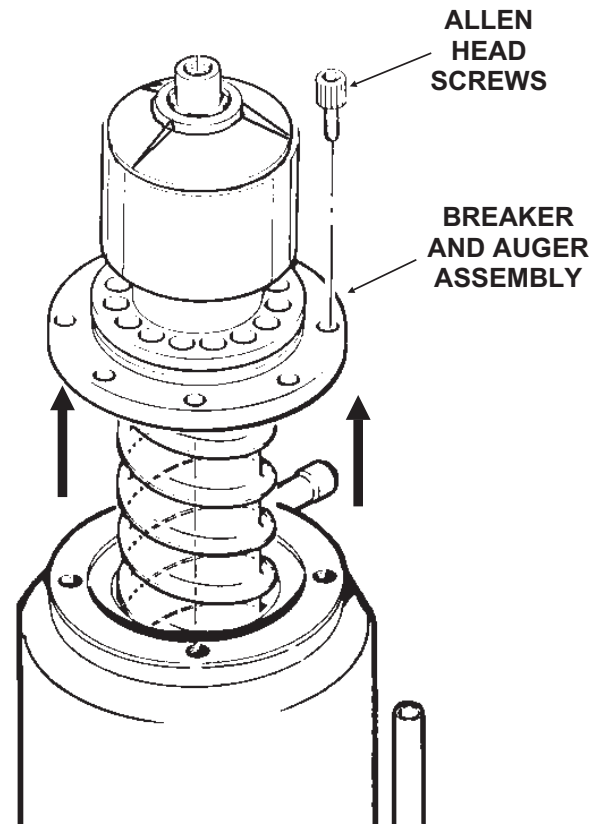

MDT5N25 & MDT5N40

SERVICE DIAGNOSIS

Symptom	Possible Cause	Probable Correction
No ice made, nothing operates	Unit off due to no power	Restore power
	Unit off due to master switch in OFF position	Switch master switch to ON
	Unit off due to low water level	Check water supply, filter, strainer, float valve. Correct water supply
	Unit off due to ice level sensors (photo-electric eyes) blocked	Check/clean ice level sensors
	Unit off due to scale on water level sensor	Clean water level sensor
	Unit off due to water temperature too high	Thermistor will shut down unit at temperatures over 110°F.
Unit operates, no ice is vended	Check for ice in the bin	If no ice, check that ice maker can make ice Check that machine cannot keep up with needs
	Check for jam up of ice in dispense chute	Pull chute down and allow ice to fall out. Return chute to its normal place.
	If there is ice, check that the bin vane rotates. if not	Check for power to the bin drive motor, if none, check condition of Touch-Free ice sensor.
	If there is power to the bin drive motor, but the vane does not turn	Disconnect electrical power, remove all ice, check mechanical condition of ice vane. Replace if broken. If ice vane is mechanically sound, check bin drive, replace if broken.
Compressor on, auger motor is off	Auger motor windings open	Replace auger motor
	Auger motor relay does not make	Replace circuit board
	Contactors stuck	Replace contactor
Compressor does not operate	Off due to high pressure control open	Check condenser, fan motor, fan blade, or water supply on water cooled.
	Contactors coil is open	Replace contactor
	Contactors contacts do not make	Replace contactor
	Start capacitor failed	Replace start capacitor
	Potential relay failed	Replace relay
	Compressor windings open	Replace compressor
	Compressor locked	Replace compressor

MDT5N25 & MDT5N40

SERVICE DIAGNOSIS

Symptom	Possible Cause	Probable Correction
No water is vended	Check ice vending system, if no ice will dispense, check the splash panel cleaning switch	Allow 2 minutes for system to reset
	Check water supply	Restore water supply
	Check inlet water valve	Replace valve if necessary
Makes ice, but with excessive noise	Mineral scale on auger or evaporator	Clean ice making system with Scotsman Ice machine cleaner
	Dry top bearing	Check top bearing for proper lubrication
	Dry auger drive gear motor	Check auger drive for proper lubrication
	Auger motor rotor bearings worn	Replace auger motor
	Vibration from loose panel or tubing	Locate vibrating component and secure it.
	Low water level	
Check for thermistor (water level sensor) not shutting unit off when there is lack of water.		
Will not dispense ice	Vane turns & ice is available but will not flow out of bin	Check position of bin bottom. It must have its slot over the ice dispense spout.
		Check condition of bin walls. They must be smooth and the bin must be round. Replace if rough or out of round.
Touch Free ice dispensing system does not operate water solenoid or dispense motor	Check splash panel cleaning switch	Push to reset or wait 2 minutes for the board to reset itself
	Check for power to motor or solenoid	If power, check motor or solenoid. If no power, replace touch free sensors
	If new touch free sensors do not fix problem	Replace circuit board.
No power to compressor contactor and auger motor	Power light on, but Bin empty light not on	Check for ice between electric eyes or dirty eyes.
	Power light not, bin empty light on, but Low water light on	Not enough water.
		Water too hot
	Electric eyes failed	Replace photo electric eyes
	Thermistor failed	Replace water level sensor
Circuit board failed	Replace circuit board	

SERVICE DIAGNOSIS: Circuit Board

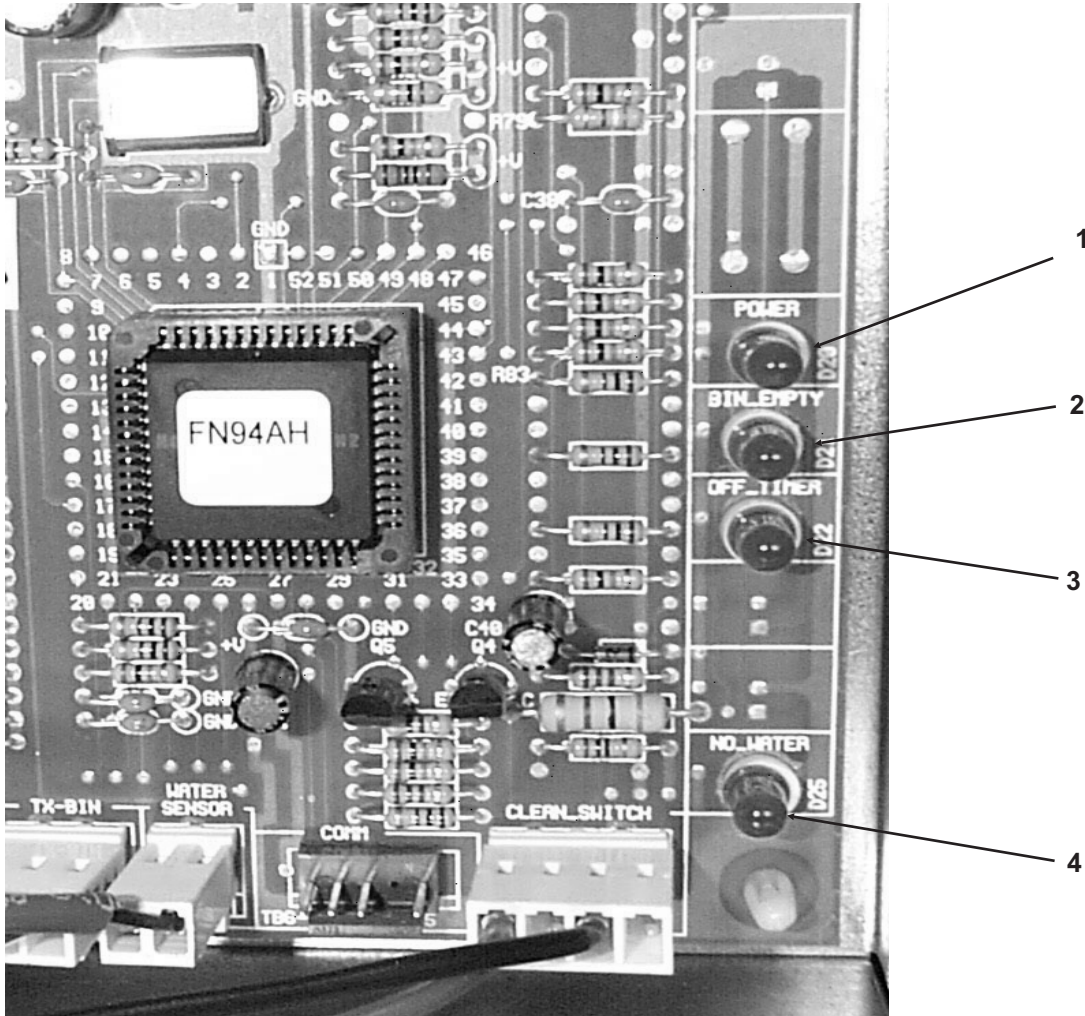

Explanation of Indicator Light	Position On Board	Name and Meaning of Light or Reset
On at all times when the master switch is ON and machine is connected to electrical power.	1	Power , ON = Normal
On when ice level is low (unit making ice).	2	Bin Empty , ON = Needs Ice
Normal 6 minute off/delay start. To prevent short cycling, the machine will not restart after any shut off (except power to the board) until 6 minutes have passed.	3	Off Timer , ON = Unit cycling off
On when water level is low in the reservoir.	4	No Water , ON = Trouble

MDT5N25 & MDT5N40

REMOVAL AND REPLACEMENT

WATER RESERVOIR

1. Shut off the water supply to the icemaker.
2. Remove front panel and reservoir cover.
3. Disconnect inlet water line from valve.
4. To remove just the float, push the locking tab at the back of the valve mounting block in and lift the valve and block up and out of the reservoir tank.

Note: inside the valve, there is a plunger which may be replaced separately, if desired.

5. To remove reservoir, remove drain hose from reservoir.
6. Remove evaporator inlet hose from reservoir.
7. Remove mounting screws from reservoir bracket, and remove reservoir from icemaker.
8. Reverse to reassemble.

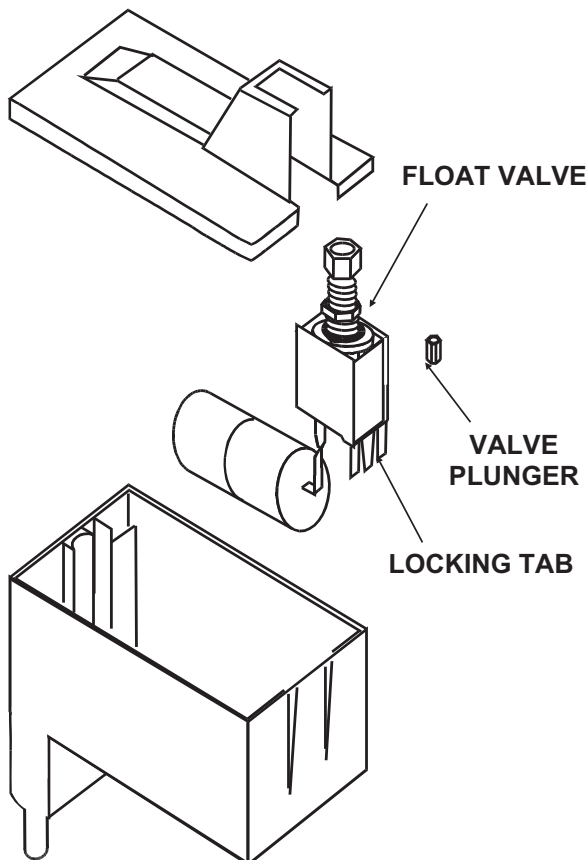

BIN CONTROLS (Ice Level Sensors)

1. Disconnect electrical power.
2. Remove front panel.
3. Remove control box cover.
4. Locate bin top, in front of and behind it are two rubber bin control grommets.
5. Pull each bin control out, and in the control box, disconnect the electrical leads connecting the bin control to the circuit board.
6. Reverse to reassemble, be certain that the bin controls are aligned so that the ice level sensors are visible (centered) through the holes in the ice chute.

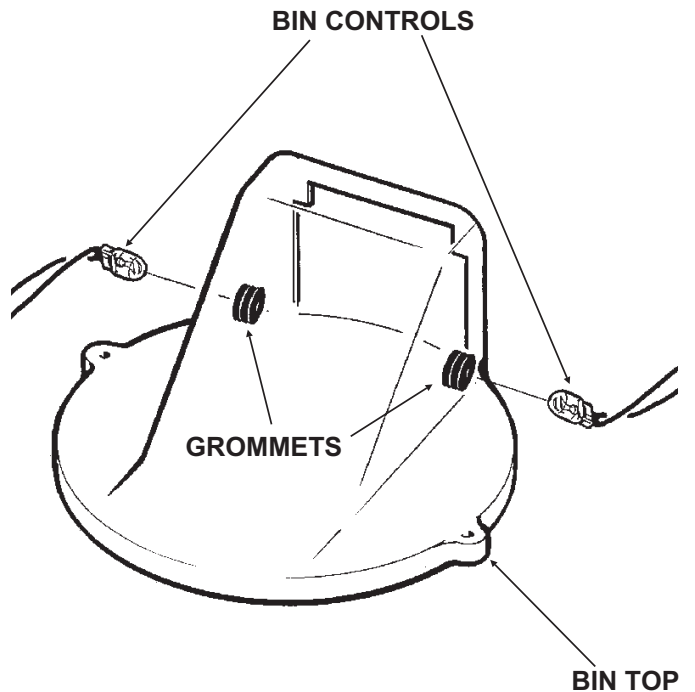

REMOVAL AND REPLACEMENT: Bearing And Breaker

Note: Removal of the auger, water seal, evaporator and gearmotor must begin at the top of the assembly.

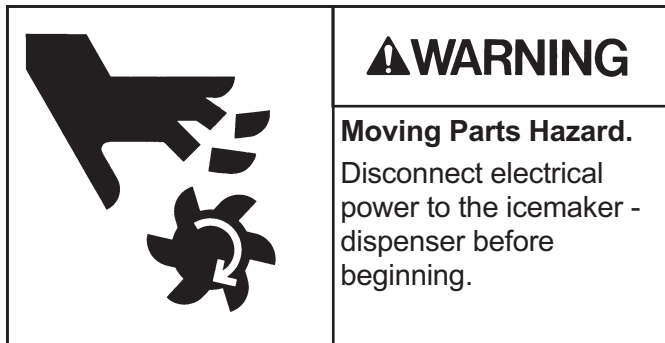

To Remove the Breaker Bearing Assembly:

1. Remove panels and disconnect electrical power.
2. Move bail clamp back and remove ice chute cover.
3. Unscrew and remove ice sweep.
4. Remove insulation halves from outside of ice chute, loosen band clamp under ice chute, lift up and remove ice chute.
5. The breaker may be removed from the auger and evaporator without disturbing the auger.
 - a. Unscrew breaker cover from breaker (left hand threads)
 - b. Unscrew auger stud from top of auger.

- c. Unscrew 4 allen head cap screws holding breaker to evaporator.
- d. Lift up, and remove breaker/bearing assembly from auger & evaporator.
6. Service the bearing. Check for rust, rough spots and damage.
 - a. The bearing is pressed into the breaker, to remove the bearing and replace it an arbor press is needed.
 - b. Replace lower seals before installing new bearing in breaker.

Note: seals must be pressed in with a tool pushing against the outer edge only, they will not install by hand.

Replace parts as required. Re-grease bearing with Scotsman part no. 19-0609-01 bearing grease. Replace top seal, and check the o-rings, replace if cut or torn.

7. Reverse to reassemble: specific tools and materials are required to install properly.

- a. Add food grade grease such as Scotsman part number 19-0569-01 to the seal area before installing on the auger.
- b. Check the seal to shaft areas for cuts, or rough spots: none are permitted.

Steps 3 - 5a

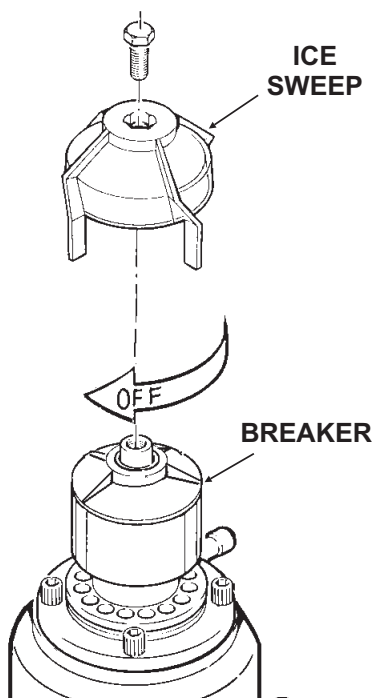

Step 5 b

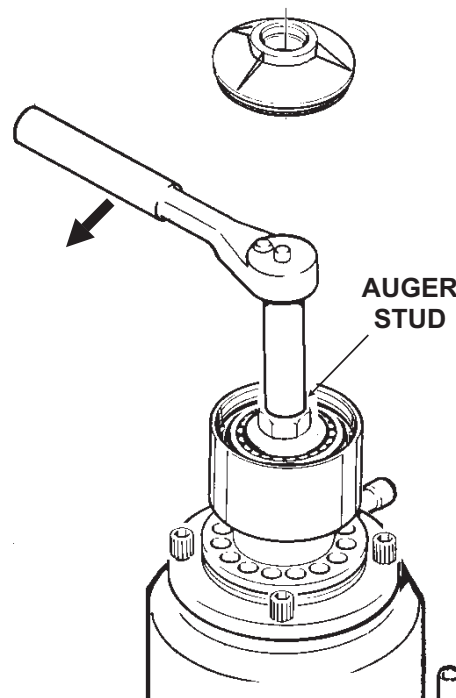

Steps 5c - 6

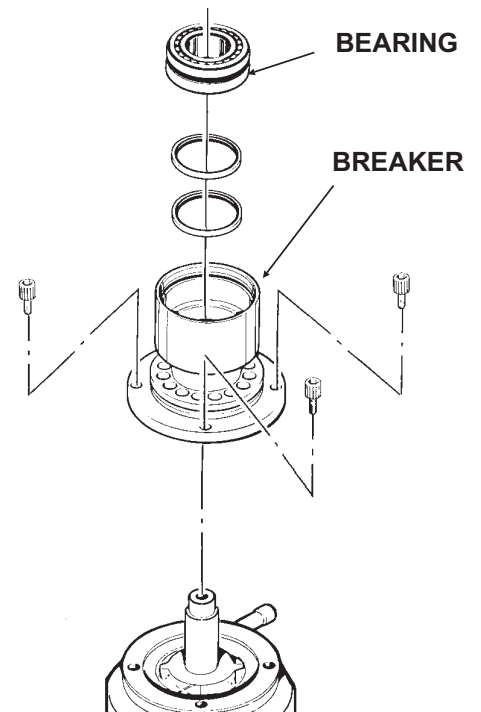

MDT5N25 & MDT5N40

REMOVAL AND REPLACEMENT

To Remove the Auger:

Turn off the water to the machine, and unclip the evaporator drain hose, pull it down and drain the evaporator into the bin or a container.

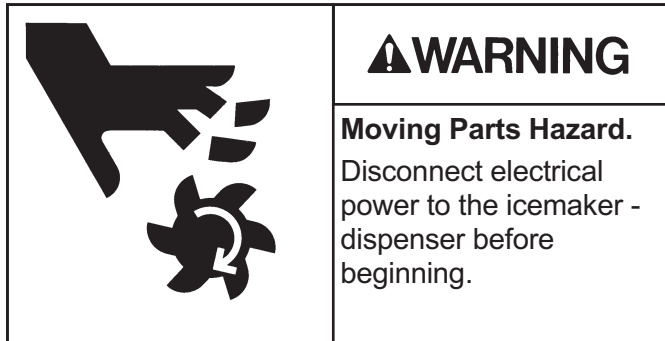

1. The top panel must be removed.
2. Remove ice chute cover.
3. Unscrew ice sweep.
4. Remove ice chute body.
5. The auger and breaker/bearing may now be removed as an assembly.
 - a. Unscrew 4 allen head cap screws holding breaker to evaporator.

- b. Lift up on breaker and remove auger from evaporator.

Note: If the auger is stuck, the breaker must be removed from the auger.

The breaker may be removed from the auger and evaporator without disturbing the auger.

- a. Unscrew breaker cover from breaker (left hand threads)
 - b. Unscrew auger stud from top of auger.

BREAKER AND AUGER ASSEMBLY

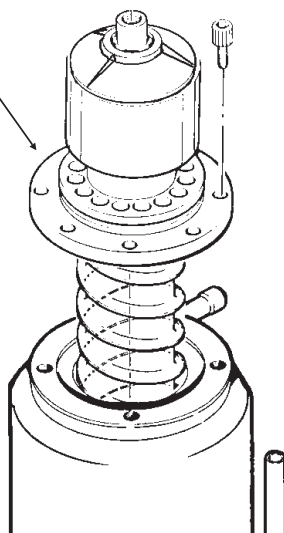

- c. Unscrew 4 allen head cap screws holding breaker to evaporator.
 - d. Lift up & remove breaker from evaporator.
 - e. If the auger is stuck use a slide hammer type puller to pull on the auger at the threaded hole. The size of that hole is 5/8"-18.

Inspect the auger, the critical areas of the auger are:

1. The auger body. It should be clean and shining. Sometimes an auger will appear clean when wet, but after it is dry it will be seen to be stained. Scrub the auger with ice machine cleaner and hot water.

WARNING

Ice machine cleaner is an acid. Handle it with extreme care, keep out of the reach of children.

2. The water seal area. Because the auger has been removed, the water seal will have to be replaced. Remove the water seal top half from the auger, and inspect the auger for minerals clean as required.

SLIDE HAMMER PULLER

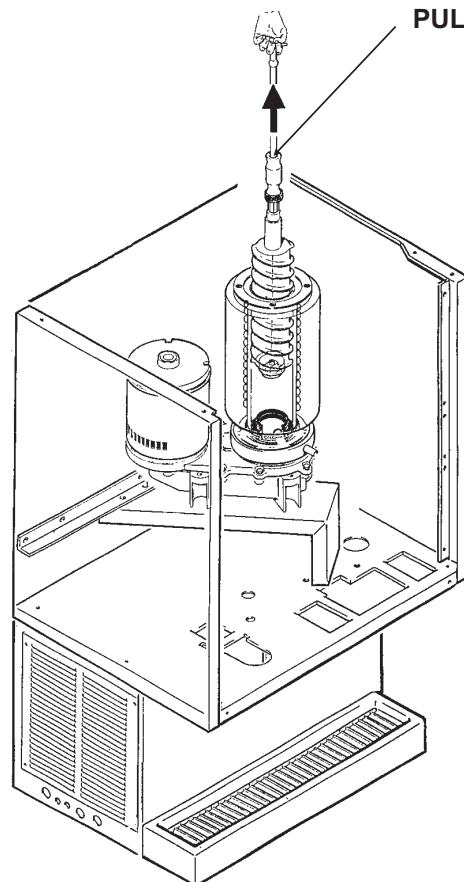

REMOVAL AND REPLACEMENT: Water Seal

To Remove the Water Seal:

(Assuming all steps to remove the auger have been performed.)

1. The gearmotor/evaporator assembly will have to be exposed. (See illustration - next page)
2. Remove the 4 hex head cap screws holding the evaporator to the gearmotor assembly. Lift the evaporator up and off of the gearmotor.
3. Remove the snap ring or wire retainer from the groove under the water seal.
4. Pull or drive out the lower half of the water seal.

To Replace the Water Seal:

1. Lubricate the water seal with water, and push the water seal into the bottom of the evaporator slightly past the groove for the snap ring.

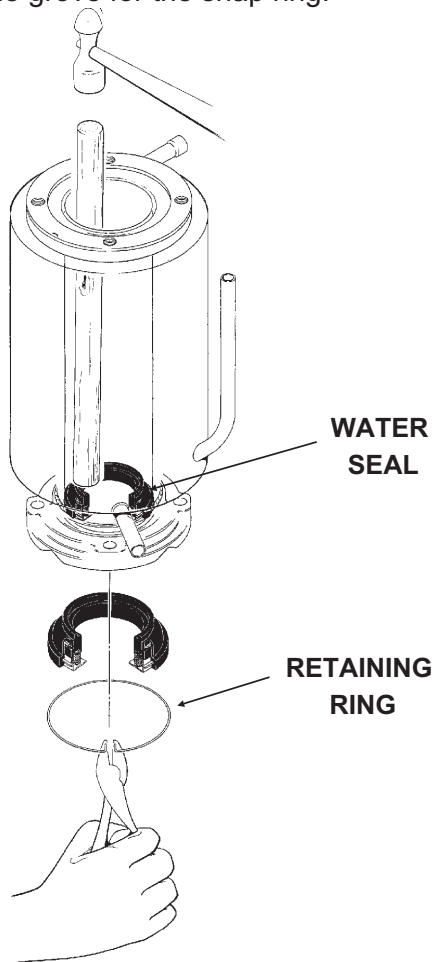

2. Replace the snap ring and pull the water seal down against it.
3. The part of the water seal that rotates with the auger must also be replaced. Remove the old part from the auger and clean the mounting area.
4. Place a small bead of food grade silastic sealant (such as 732 RTV or Scotsman part number

19-0529-01) on the area of the auger where the water seal is to be mounted.

5. Carefully push the water seal (rubber side against the auger shoulder and the silastic.)

CAUTION

Do not get any silastic onto the face of the seal.

6. Allow the auger and seal to air dry until the silastic is dry on the surface.

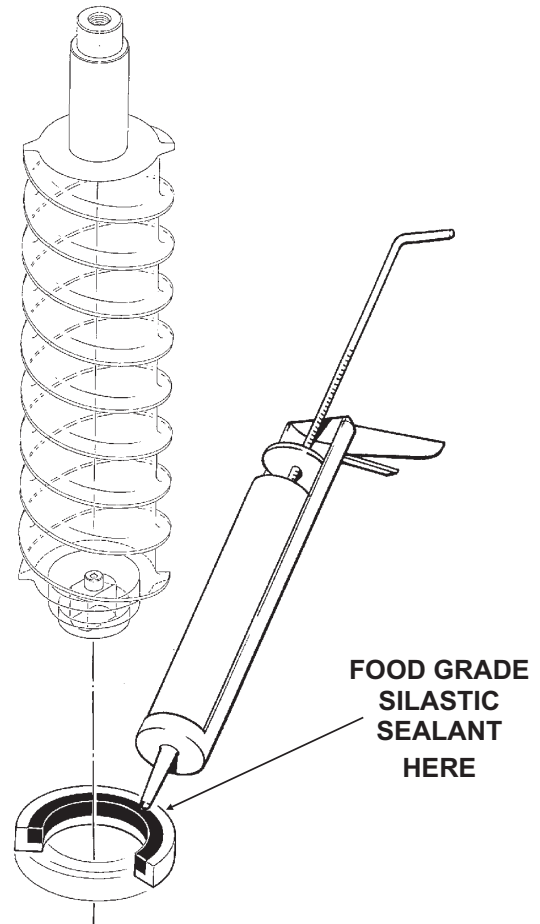

7. If the original water seal was leaking, it would be a good idea to inspect the interior of the gearmotor.

MDT5N25 & MDT5N40

REMOVAL AND REPLACEMENT

To Replace the Evaporator:

(Assuming all the steps for removal of the thrust bearing, breaker, auger, and water seal have been performed.)

1. Discharge the refrigerant from the ice maker.
2. Unswheat the refrigerant connections:
 - a) At the thermostatic expansion valve outlet.

CAUTION

Heat sink the TXV body when unswearing or resweating the adjacent tubing.

- b) At the suction line at the joint about 3" from the evaporator.
3. Remove the evaporator.
 4. Unswheat the drier from the liquid line.
 5. After installing a new water seal in the new evaporator (see "To Replace the Water Seal") sweat in the new evaporator at the old tubing connections.
 6. Install a new drier in the liquid line.

7. Evacuate the system until dehydrated, then weigh in the nameplate charge. Check for leaks.

8. Install auger, breaker, breaker bearing assembly, and ice discharge chute in reverse order of disassembly.

To Reassemble the Evaporator and Auger

1. After the gearmotor has been inspected, fasten the evaporator to the gear motor, be sure that the number of shims indicated on the gear case cover is in place between the gearcase cover and the drip pan gasket. Torque the bolts to 110 inch pounds.

2. Lower the auger into the evaporator barrel, slightly turning it to match up with the drive end. Do Not Drop Into the Evaporator.

3. Complete the reassembly by reversing the disassembly for the breaker & thrust bearing assembly.

For Access to the Evaporator to Gearmotor bolts:

1. Remove upper front and top panels.
2. Remove screws holding control box assembly to the cabinet, move the control box out of the way, temporarily secure to cabinet.
3. Remove the upper half of the ice chute.
4. Remove the ice sweep.
5. Loosen clamp under ice chute, and remove the lower half of the ice chute.
6. Remove the 2 screws securing the front portion of the gearmotor support to the cabinet
7. Move the the gearmotor - evaporator to the right: space is now available for removal of the evaporator and gearmotor bolts. When reassembling, reverse the above steps.

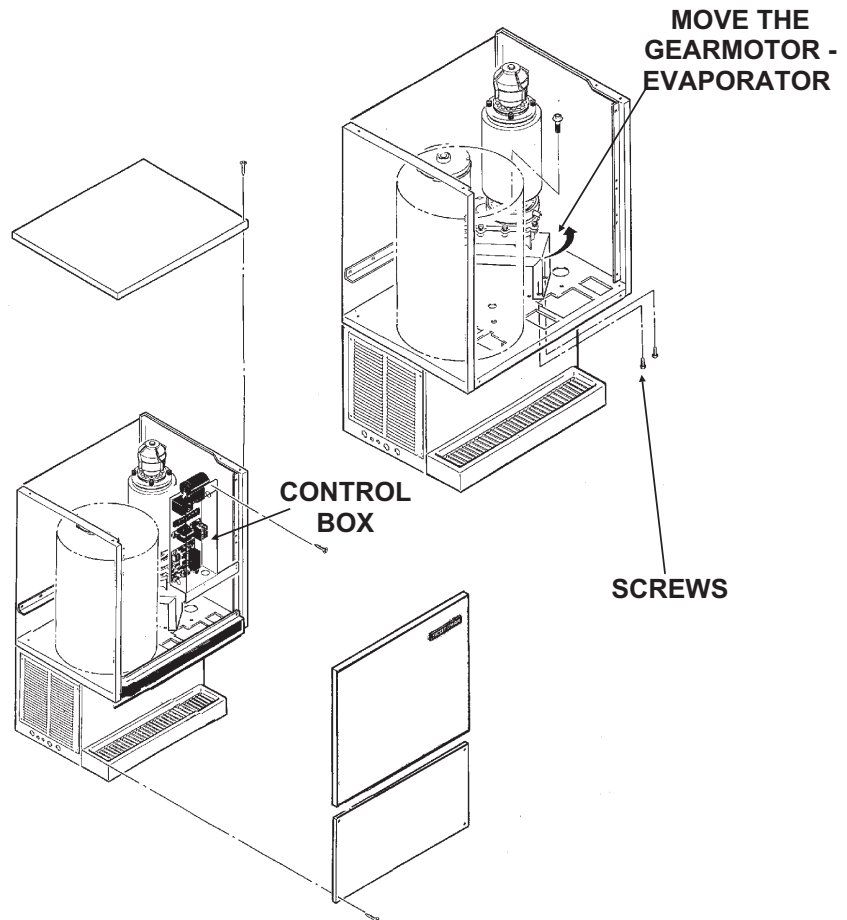

TO REMOVE AND REPAIR THE GEARMOTOR ASSEMBLY

(Assuming that the procedures through removal of the water seal have been performed.)

	<h3>⚠ WARNING</h3>
	<p>Electrical Shock Hazard.</p> <p>Disconnect electrical power to the icemaker - dispenser before beginning.</p>

onto the lower case, cover will have to be moved closer to the second gear after the output gear has cleared the second gear top bearing.

E) After the case is together, and the locating pins are secure in both ends, replace all cap screws.

4. Bench test the gearmotor, check for oil leaks, noise, and amp draw.

1. Remove the electrical wires from the gear drive motor.
2. Unscrew the 4 cap screws holding the gearmotor to the gearmotor plate.
3. Remove the gearmotor from the icemaker.

To Inspect the gearmotor.

A) Remove the cap screws holding the gearmotor case halves together and pry the two cases apart.

B) To lift off the cover, lift up until you can feel internal contact, then pull the cover towards the output gear end, and then lift the cover (with drive motor attached) up and away from the gear motor case.

Note: The case cover output gear, bearings, and shaft are one pressed together assembly. Replace as a unit.

C) Inspect the oil, gears, and bearings. If the oil level and condition is acceptable, quickly check the gears and bearings. They are likely to be fine if the oil is.

If there is evidence of water in the oil (rusty bearings and gears; the oil having a creamy white appearance; oil level too high) carefully inspect the bearings and gears. If in doubt about the condition of a part, replace it. The oil quantity is 16 fluid ounces, do not overfill.

Note: The gears and bearings are available only as pressed together sets.

D) After replacing parts as required, (if any) reassemble the gearcase. The two smaller gears and the oil should be in the lower case, the output gear will be with the cover. As you lower the cover

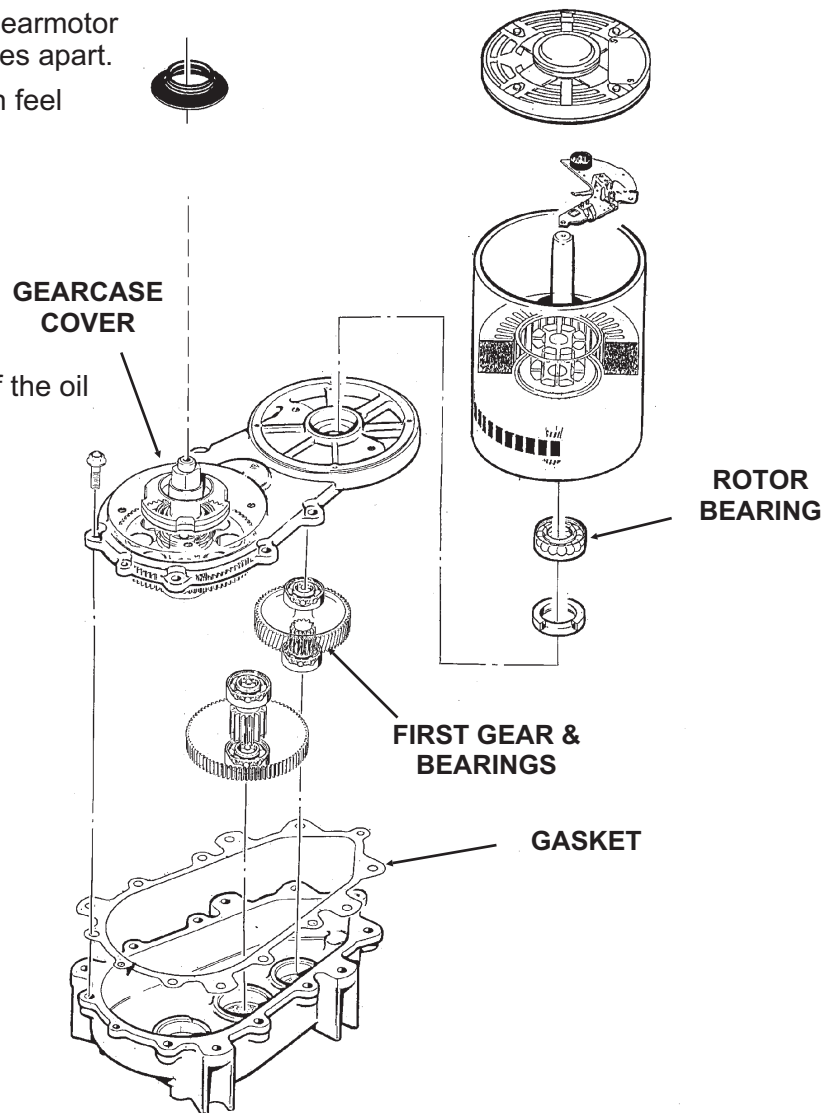

MDT5N25 & MDT5N40

REFRIGERATION SERVICE: R-404A (HP62)

THIS ICE MACHINE USES HP62 REFRIGERANT AND POLYOLESTER COMPRESSOR OIL.

DO NOT USE MINERAL OIL IN THIS REFRIGERATION SYSTEM.

- R-404A is a “Near Azeotrope”, and therefore liquid charging is required.
Weigh into the discharge side as much as possible of the charge as liquid refrigerant.
Install a sight glass between the manifold and the suction side hose. Carefully meter liquid refrigerant into the suction side, using the manifold valve to “flash off” the liquid before it enters the ice machine. Do this until the proper charge has been weighed into the system.
- When the system is serviced, a special liquid line dryer is required.
- Polyolester oil absorbs water very easily, and therefore when the system is opened for service, it must be re-sealed as soon as possible (15 minutes maximum).
- Special leak detection equipment is required to locate small refrigerant leaks. Usually a leak detector capable of detecting a Halogenated refrigerant or HFC-134A will work. Check with the leak detector manufacturer if in doubt.
- As with any other refrigerant, do NOT mix HP62 with pressurized air when leak testing.

Pressure-Temperature Chart for HP62

VAPOR		VAPOR	
TEMP.	PRESSURE	TEMP.	PRESSURE
(DEG F)	(PSIG)	(DEG F)	(PSIG)
-20	17	70	146
-18	18	72	150
-16	20	74	155
-14	21	76	161
-12	23	78	166
-10	24	80	171
-8	26	82	177
-6	28	84	182
-4	29	86	188
-2	31	88	194
0	33	90	200
2	35	92	206
4	37	94	212
6	39	96	219
8	41	98	225
10	43	100	232
12	46	102	239
14	48	104	246
16	50	106	253
18	53	108	260
20	55	110	268
22	58	112	275
24	60	114	283
26	63	116	291
28	66	118	299
30	69	120	307
32	72	122	316
34	75	124	324
36	78	126	333
38	81	128	342
40	85	130	351
42	88	132	360
44	91	134	370
46	95	136	379
48	99	138	389
50	102	140	399
52	106	142	409
54	110	144	420
56	114	146	430
58	118	148	441
60	123	150	452
62	127	152	464
64	132	154	475
66	136	156	487
68	141	158	499

REFRIGERATION SERVICE

General Information:

Work on the refrigeration system should only be done when it is certain that the system needs repair.

- **Refrain from checking refrigeration pressures without reason.** Visual inspection of the water system, observation of the ice formation, amp draw, voltage, and other techniques will lead to proper diagnosis. Scotsman also recommends that, at the time of initial start up, gauges not be used.
- If gauges must be used, don't always check the high side pressure. If the condenser is clean and seems to be operating correctly, it most likely is. The low side pressure is more important on an ice machine than the high side.
- If gauges must be used, use very short hoses to minimize refrigerant discharged into the air.
- Refrigerant should not be added except as a way to determine the proper operation of the product. If the system was low on refrigerant, there is a leak, and it must be found and repaired.
- This system has a critical charge, it must be recharged with the correct amount of refrigerant as listed on the nameplate of the ice machine, or performance will suffer.
- Anytime the refrigeration system has been opened, the dryer should be replaced. **Note: Only a HFC type dryer should be used.**
- When brazing the tubing connections to components such as the TXV, the component must be protected by heat sink material.

Recover, reclaim or recycle refrigerant. The method chosen is up to the service company. Any refrigerant placed into a Scotsman ice machine must meet ARI spec 700-88. Reclaim programs are available through most refrigerant wholesalers.

Access Valves: To use the access valves:

Remove the cap from the stem, use a 3/16" allen wrench to check that the valve is CLOSED. The remove the core cap.

Close the valve and replace the caps when the job is finished. The valve must be closed and the caps must be on or the valve will leak.

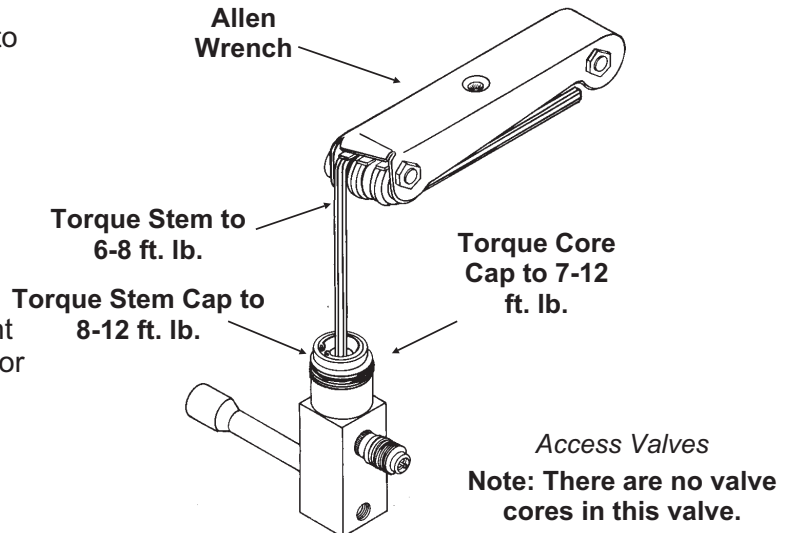

MDT5N25 & MDT5N40

CIRCUIT BOARD SERVICE

Printed Circuit Board Handling Precautions

Follow these simple precautions when replacing a Printed Circuit Board

1. Keep the replacement PC Board in the anti-static packaging until it is ready to be installed.
2. Be sure that your hands are clean.
3. Just before touching the board, touch the cabinet of the machine to discharge any possible build up of static electricity.
4. Handle the original and replacement boards only by their outer edges.
5. Place the original board in the anti-static package for return (if in warranty).

LIQUID CHARGING

Instructions for R-404A

In preparation for charging, the low side hose should have a sight glass, and/or a restrictor device (such as a "Charge Faster") installed in it for metering liquid into the low side of the system.

1. After a thorough evacuation to at least 300 microns, shut off the manifold valves and switch off the vacuum pump.
2. Place a drum of R-404A onto an electronic scale.
3. Attach the charging hose to the drum.
4. Open the valve on the drum and purge the charging hose.
5. Zero out the scale.
6. Shut the low side access valve at the ice machine.
7. Open the discharge manifold valve full open.
8. Watch the scale, when the correct charge is shown, shut the manifold valve.

Note: If all of the charge will not "go in" the discharge side:

- A. Shut the discharge access valve at the ice machine.
- B. Switch the machine on.
- C. Open the low side access valve at the ice machine.
- D. Open the low side manifold valve and observe the sight glass to be certain that only gas is flowing into the system.
- E. When the proper charge is indicated on the scale, shut off the manifold valve(s).

9. Shut off the valve on the refrigerant drum.
10. Re-open the manifold valves until all liquid has flowed out of the hoses.
11. Shut the low side access valve on the ice machine.
12. Remove hoses from ice machine and replace all caps.