

NME1854R & FME2404R SERVICE PARTS

This parts list contains the service parts and wiring diagrams for this model. Check the model number in question to be sure that it is applicable to this parts list.

TABLE OF CONTENTS

Cabinet	2
Refrigeration	3
Water	4
Gearmotor	5
NME Evaporator	6
FME Evaporator	7
Control Box	8
Remote Condenser	9
Wiring Diagrams	10

NME1854R & FME2404R SERVICE PARTS

Cabinet Assembly

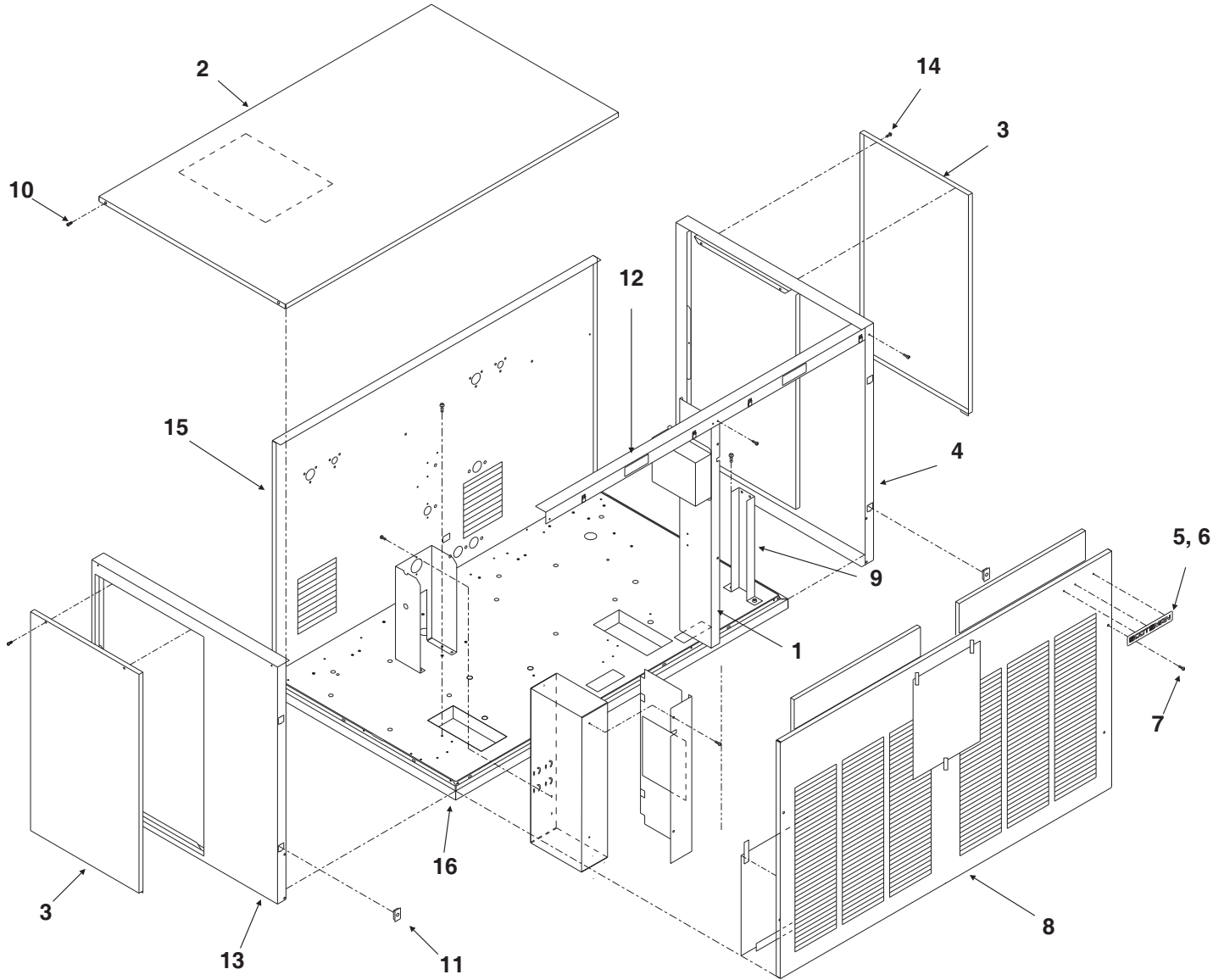

ITEM NUMBER	PART NUMBER	DESCRIPTION
1	A34286-001	Center Support
2	A32461-002	Top Panel, S.S.
3	A34038-002	Service Panel, S.S.
4	A33292-002	Right Side Panel, S.S.
5	03-0271-00	Speed Clip
6	15-0808-01	Emblem, gray
7	03-1419-22	Screw

ITEM NUMBER	PART NUMBER	DESCRIPTION
8	A34294-002	Front Panel, S.S
9	A37482-001	Reservoir bracket
10	03-1531-01	Screw
11	02-0836-00	Catch
12	A34287-001	Support
13	A32435-002	Left Side Panel, S.S.
14	03-1404-12	Screw
15	A36517-002	Rear Panel
16.	A36554-001	Base

NME1854R & FME2404R SERVICE PARTS Refrigeration System

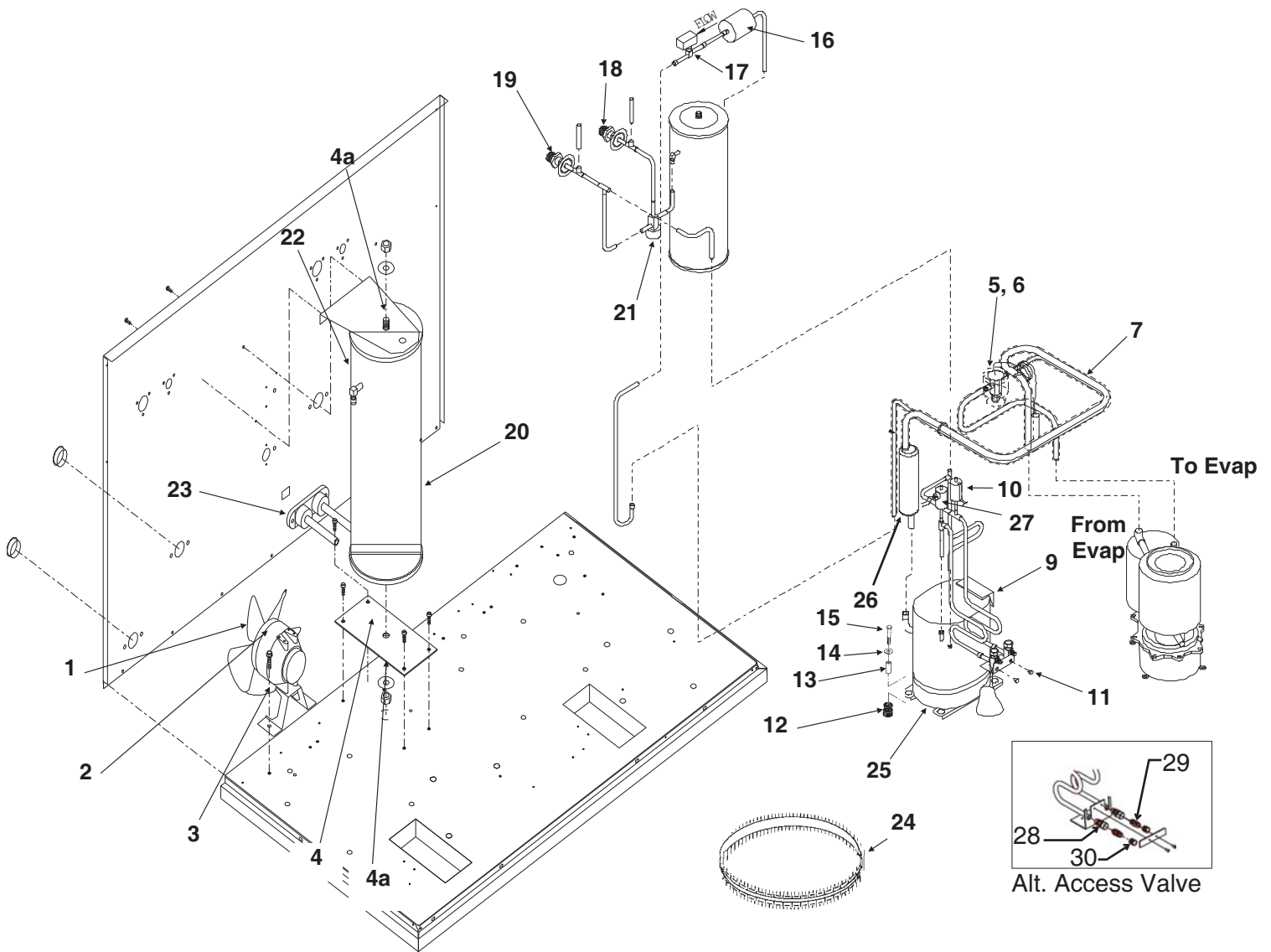

ITEM NUMBER	PART NUMBER	DESCRIPTION	ITEM NUMBER	PART NUMBER	DESCRIPTION
1	18-8708-01	Fan Blade	17	12-2135-02	Liquid line valve
2	12-1576-02	Fan Motor	18	16-0850-01	Liquid line fitting
3	A35246-001	Fan Bracket	19	16-0850-03	Discharge line fitting
4	A31801-002	Bracket	20	16-0761-01	Receiver
4a	03-1406-13	Nut	21	11-0422-25	Discharge pressure control
5	A32961-020	Insulation Kit (3 piece)	22	A32968-001	Receiver bracket
6	11-0488-21	Thermo Expansion Valve	23	02-3692-22	Drain fitting
7	A36496-001	Suction Line	24	12-1868-03	Crankcase heater
8	A34285-001	Filler panel	25	18-8768-22	Compressor 208-230/60/1 Overload is internal
9	16-0832-20	Access valve		18-8768-24	Compressor 200-230/60/3 Overload is internal
9a	16-0832-02	Stem cap	Note: Replacement compressors include a new HFC dryer & single phase include starting components		
9b	16-0832-03	Core cap	26	16-0778-21	Accumulator
10	11-0501-22	Hi Pressure Cut Out	27	11-0502-21	Low pressure cut out
11	03-1645-01	Screw	28	16-1137-01	Access valve body
12	18-2200-28	Grommet	29	16-1139-01	Core
13	18-2200-27	Sleeve	30	16-1140-01	Cap
14	03-1407-07	Washer			
15	03-1405-20	Cap Screw			
16	02-3319-02	Dryer			

NME1854R & FME2404R SERVICE PARTS

Water System, Water Seal

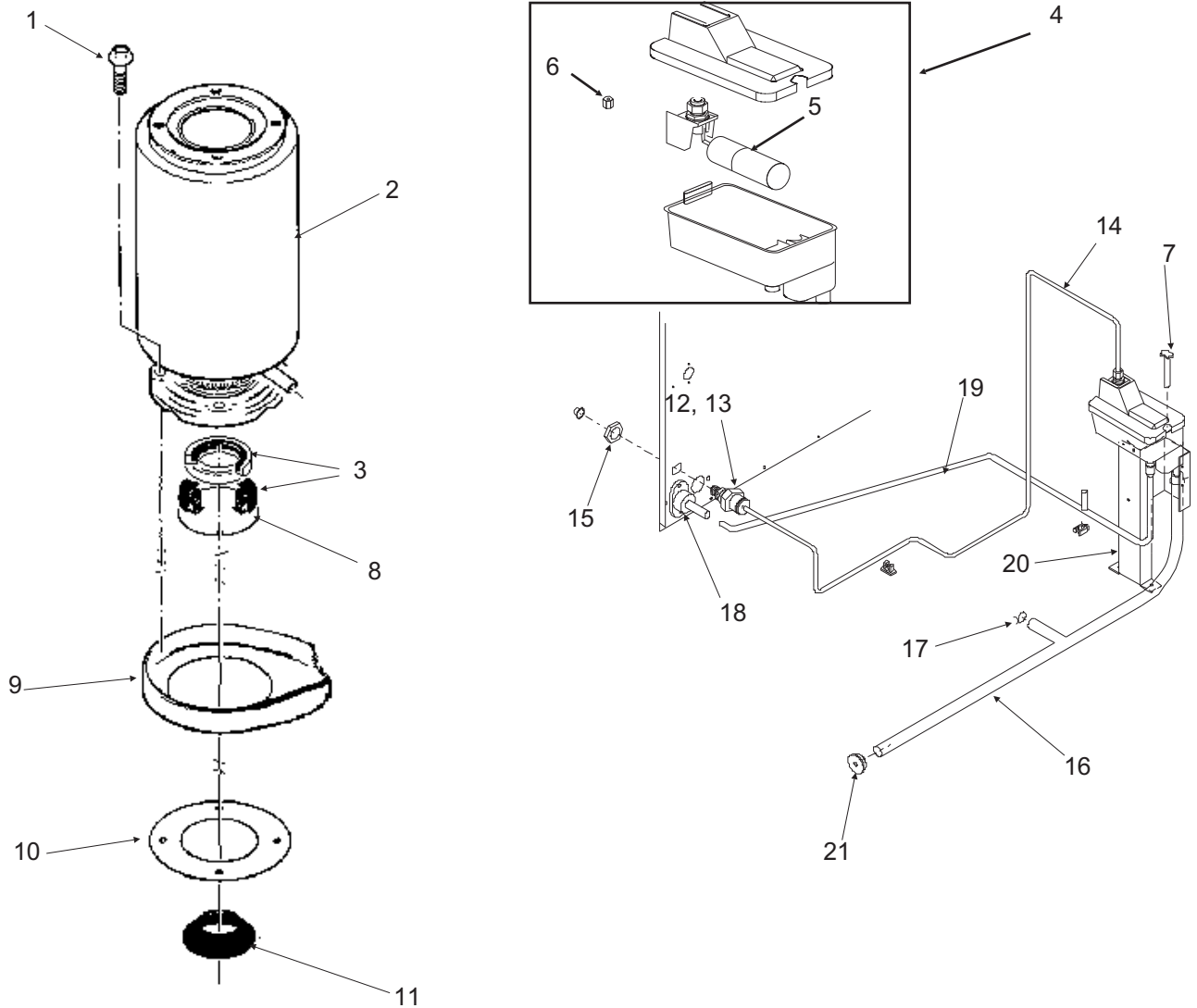

ITEM NUMBER	PART NUMBER	DESCRIPTION	ITEM NUMBER	PART NUMBER	DESCRIPTION
1	03-1405-41	Cap Screw	15	03-1394-01	Pal Nut
2	A32890-020	Evaporator	16	A36154-001	Evap. water inlet tube
3	02-0929-23	Water Seal	17	02-1338-00	Hose clamp
4	02-3266-01	Reservoir & valve	18	02-3692-22	Drain fitting
5	02-3266-02	Float valve	19	02-3826-01	Res. overflow hose (right)
6	02-3266-03	Plunger/seat		02-3826-02	Res. overflow hose (left)
7	12-2760-21	Water Level Sensor	20	A37482-001	Reservoir bracket
8	A32777-001	Retaining Ring for Seal	21	13-0840-01	Rubber cap
9	02-3837-01	Drip Pan			
10	13-0704-00	Gasket			
11	02-4663-01	Water Shed			
12	16-0835-01	Inlet fitting for plastic tubing			
13	16-1039-01	Male connector for plastic			
14	13-0895-01	Inlet tubing, 4 ft. req.			

NME1854R & FME2404R SERVICE PARTS

Gearmotor

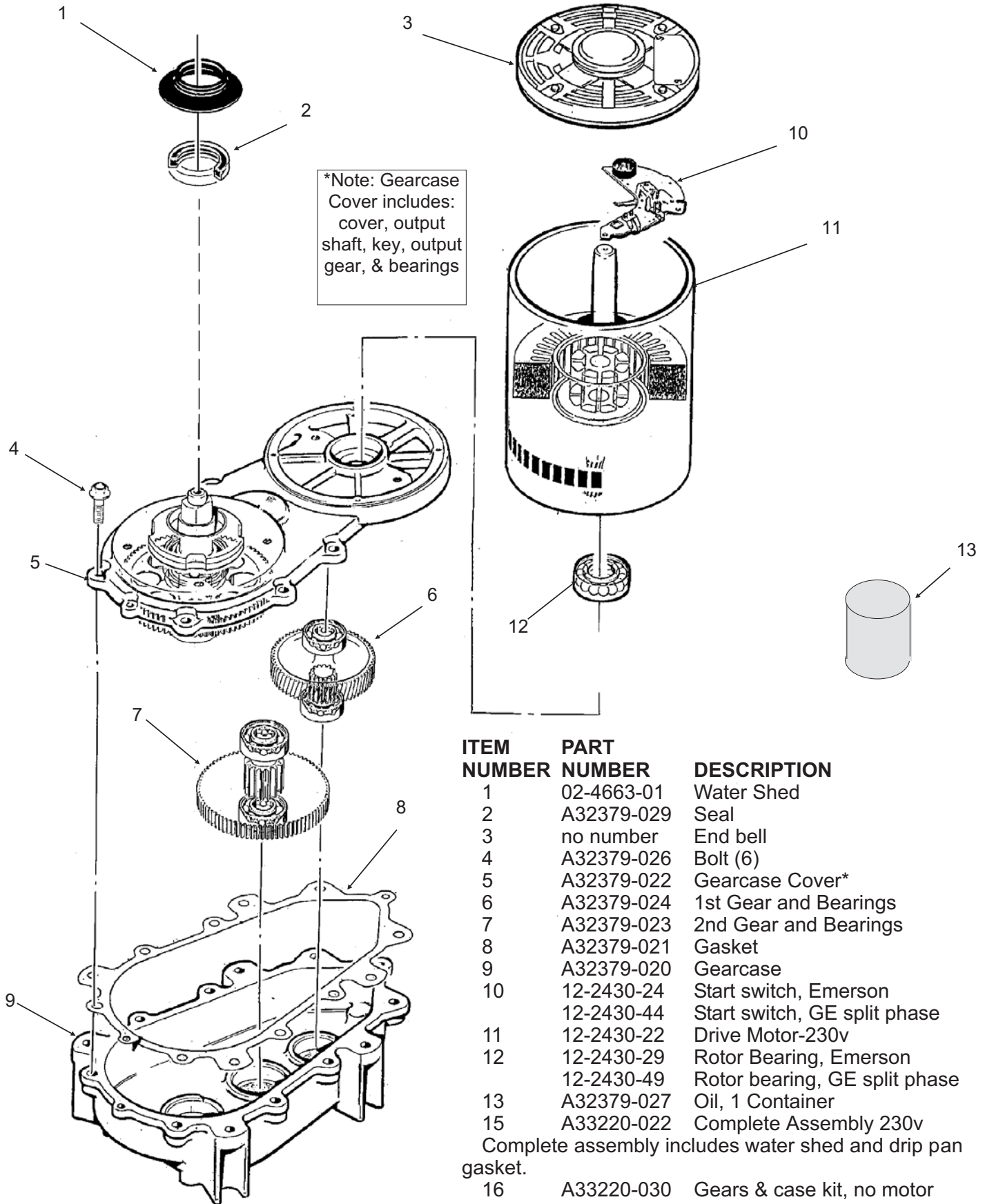

NME1854R & FME2404R SERVICE PARTS

NME Evaporator, Bin Controls

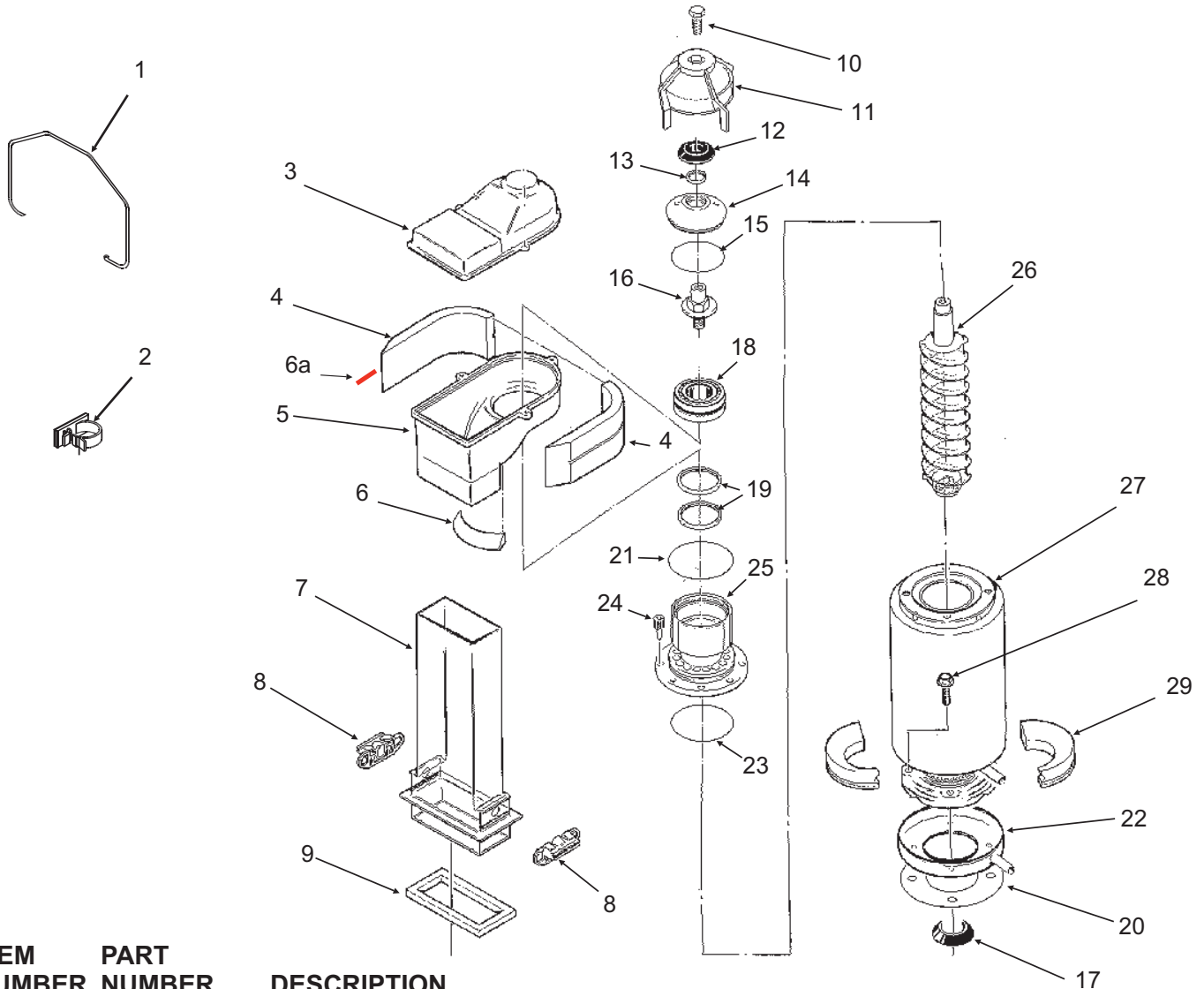

ITEM NUMBER	PART NUMBER	DESCRIPTION
1.	A34969-001	Bail clip
2.	02-3268-01	Drain tube holder
3.	02-2930-04	Ice Chute Cover
4.	A32963-001	Insulation Top (half)
5.	02-2926-01	Ice Chute Body
6.	A33102-001	Insulation Collar Inside
6a	A35419-020	Strap kit
7.	02-2929-04	Ice Chute Lower
8.	A37708-021	Bin Controls Assy. (set of 2)
9.	A32930-001	Chute Gasket
10.	03-1405-52	Hex Cap Screw
11.	02-3001-01	Ice Sweep
12.	13-0871-01	Water Shed
13.	02-2978-01	Lip Seal
14.	02-3128-20	Breaker Cover
15.	13-0617-52	O-Ring
16.	08-0660-01	Auger Stud & washer
17.	02-4663-01	Water Shed
18.	A34559-020	Bearing
19.	02-2977-01	Lip Seal
20.	13-0704-00	Drip Pan Gasket
21.	13-0617-54	O-Ring
22.	02-3837-01	Drip Pan
23.	13-0617-45	O-Ring
24.	03-1544-08	Soc. Head Screw
25.	A32900-020	Breaker (includes 12-15, 18, 19, 21, 23)
26.	A38071-022	Auger
27.	A32890-020	Evaporator
28.	03-1420-03	Cap Screw
29.	02-4358-01	Insulation

NME1854R & FMF2404R SERVICE PARTS

FME Evaporator, Bin Controls

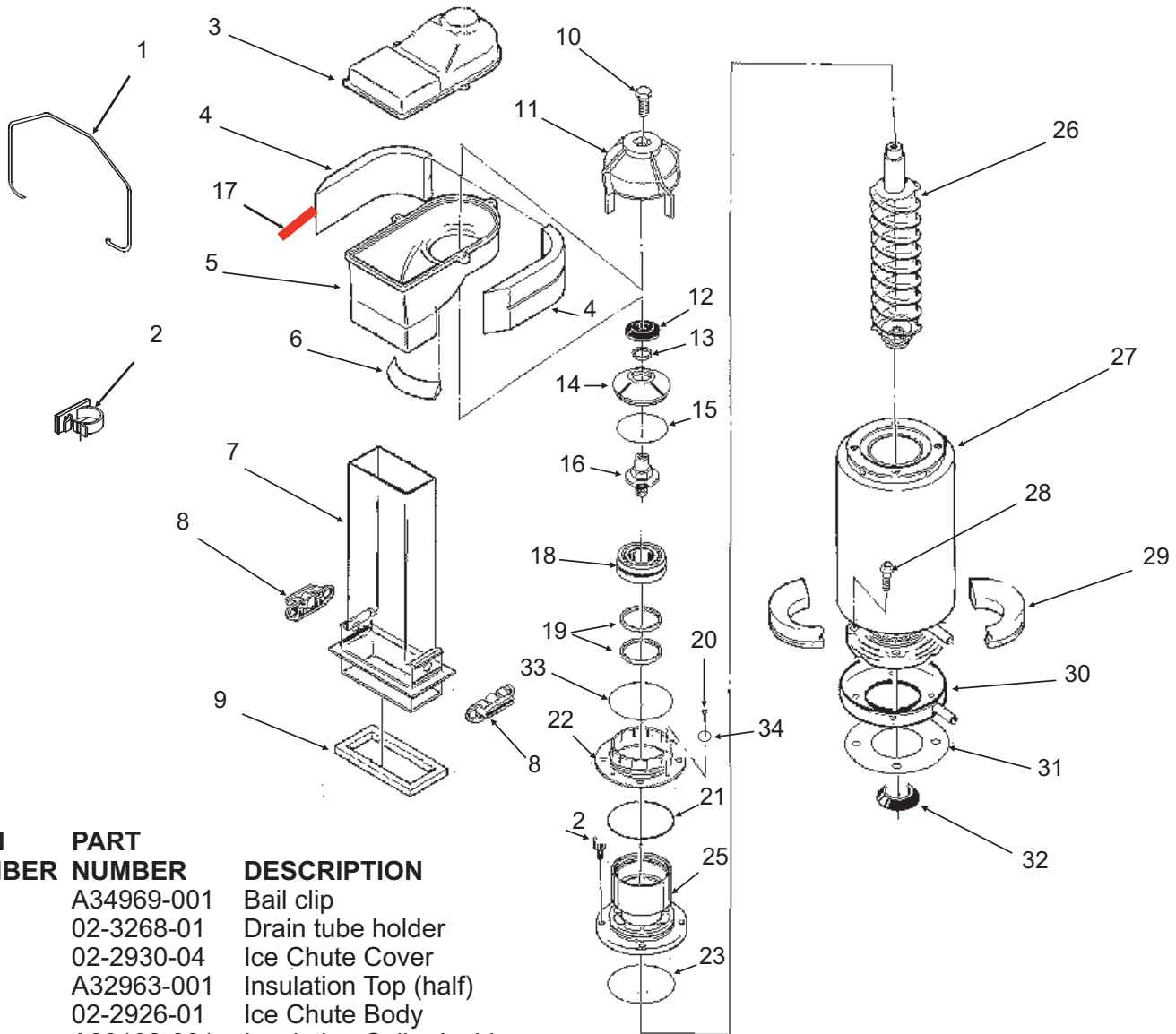

ITEM NUMBER	PART NUMBER	DESCRIPTION
1.	A34969-001	Bail clip
2.	02-3268-01	Drain tube holder
3.	02-2930-04	Ice Chute Cover
4.	A32963-001	Insulation Top (half)
5.	02-2926-01	Ice Chute Body
6.	A33102-001	Insulation Collar Inside
7.	02-2929-04	Ice Chute Lower
8.	A37708-021	Bin Controls Assy. (set of 2)
9.	A32930-001	Chute Gasket
10.	03-1405-52	Hex Cap Screw
11.	02-3001-01	Ice Sweep
12.	13-0871-01	Water Shed
13.	02-2978-01	Lip Seal
14.	02-3128-20	Breaker Cover
15.	13-0617-54	O-Ring
16.	08-0660-01	Auger Stud, thrust Washer
17.	A35419-020	Strap kit
18.	A34559-020	Bearing
19.	02-2977-01	Lip Seal
20.	03-1405-27	Screw
21.	13-0617-52	O-Ring
22.	02-2916-01	Slotted Collar
23.	13-0617-45	O-Ring
24.	03-1544-08	Soc. Head Screw
25.	A34505-020	Breaker (Divider) (includes 12-15, 18, 19, 22, 21, 23)
26.	A38071-022	Auger
27.	A32890-020	Evaporator
28.	03-1420-03	Cap Screw
29.	02-4358-01	Insulation
30.	02-3837-01	Drip Pan
31.	13-0704-00	Drip Pan Gasket
32.	02-4663-01	Water Shed
33.	13-0617-49	O-Ring
34.	03-1408-36	Washer

NME1854R & FME2404R SERVICE PARTS

Control Box

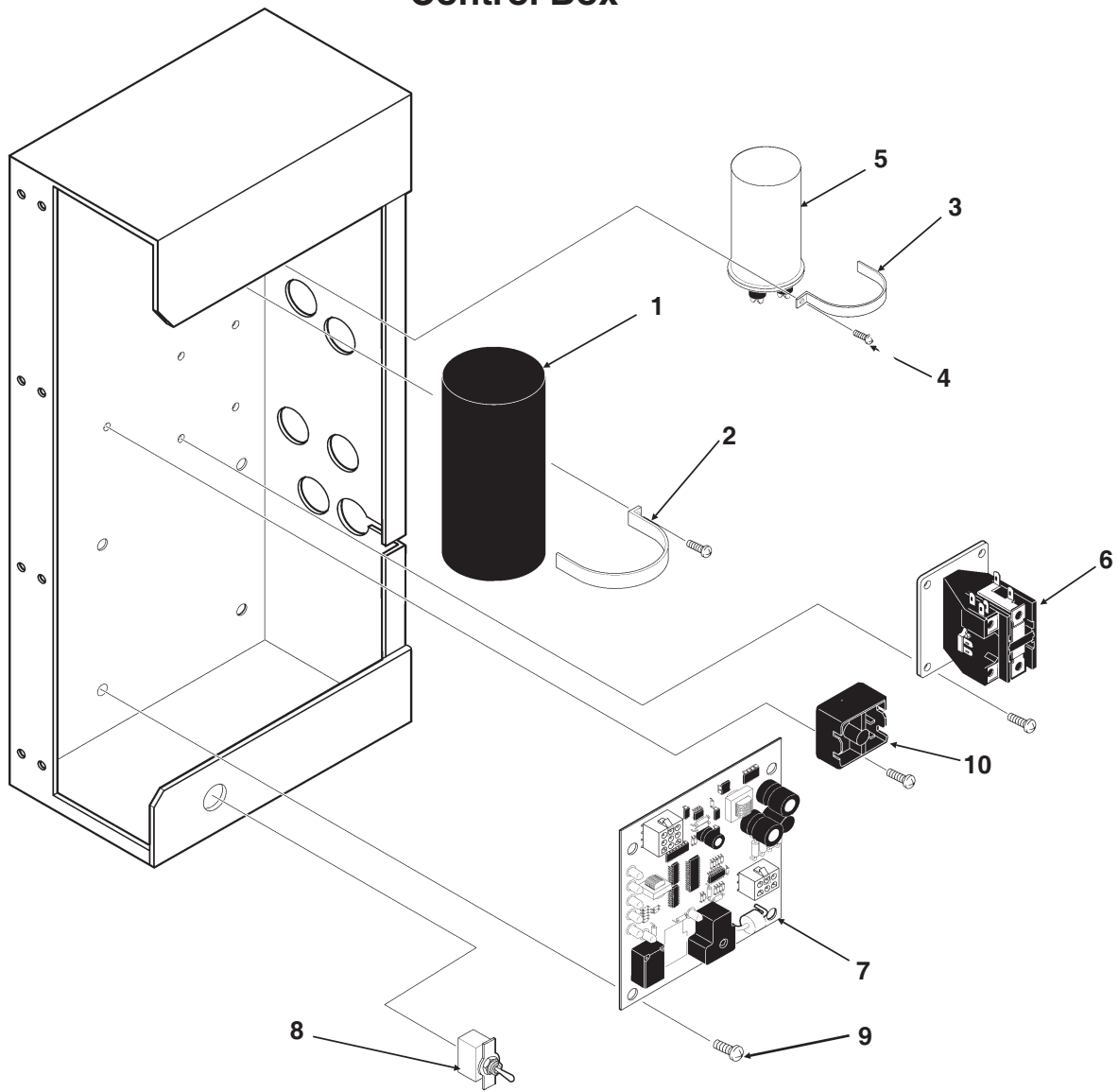

ITEM NUMBER	PART NUMBER	DESCRIPTION
1	18-1901-54	Start Capacitor.
2.	A35971-001	Start Capacitor Bracket
3.	A35971-002	Run Cap Bracket
4.	03-1638-03	Screw
5.	18-1902-45	Run Capacitor
6.	12-2469-02	Single Phase Contactor
	12-2533-02	Three Phase Contactor

ITEM NUMBER	PART NUMBER	DESCRIPTION
7	12-2835-22	Circuit Board
8.	12-0426-02	Mode Switch
9.	12-2350-01	Spacer/screw
10	18-1903-33	Potential Relay

Separate From The Control Box

11.	12-2070-04	Fan Motor Relay (in a separate control box)
12.	A37861-001	Control box cover

NME1854R & FME2404R SERVICE PARTS

Remote Condenser

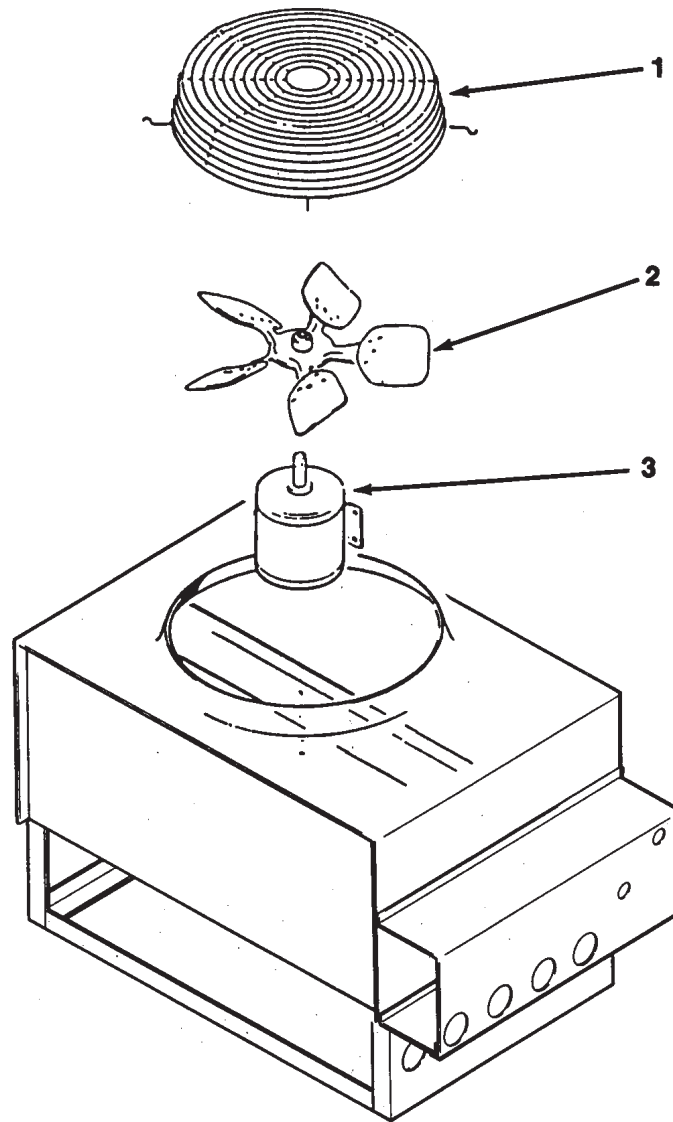

RCE502

ITEM NUMBER	PART NUMBER	DESCRIPTION
1.	02-2618-01	Fan Guard
2.	18-6304-01	Fan Blade
3.	18-5301-01	Fan Motor
4.	16-1057-01	Line connection, female half 3/8"
5.	16-1057-02	Line connection, female half 1/2"

ERC302

1	02-3575-01	Fan guard
2	18-8800-01	Fan blade
3	18-8796-32	Fan motor

NME1854R & FME2404R SERVICE PARTS

Component Layout Diagram 208-230/60/1

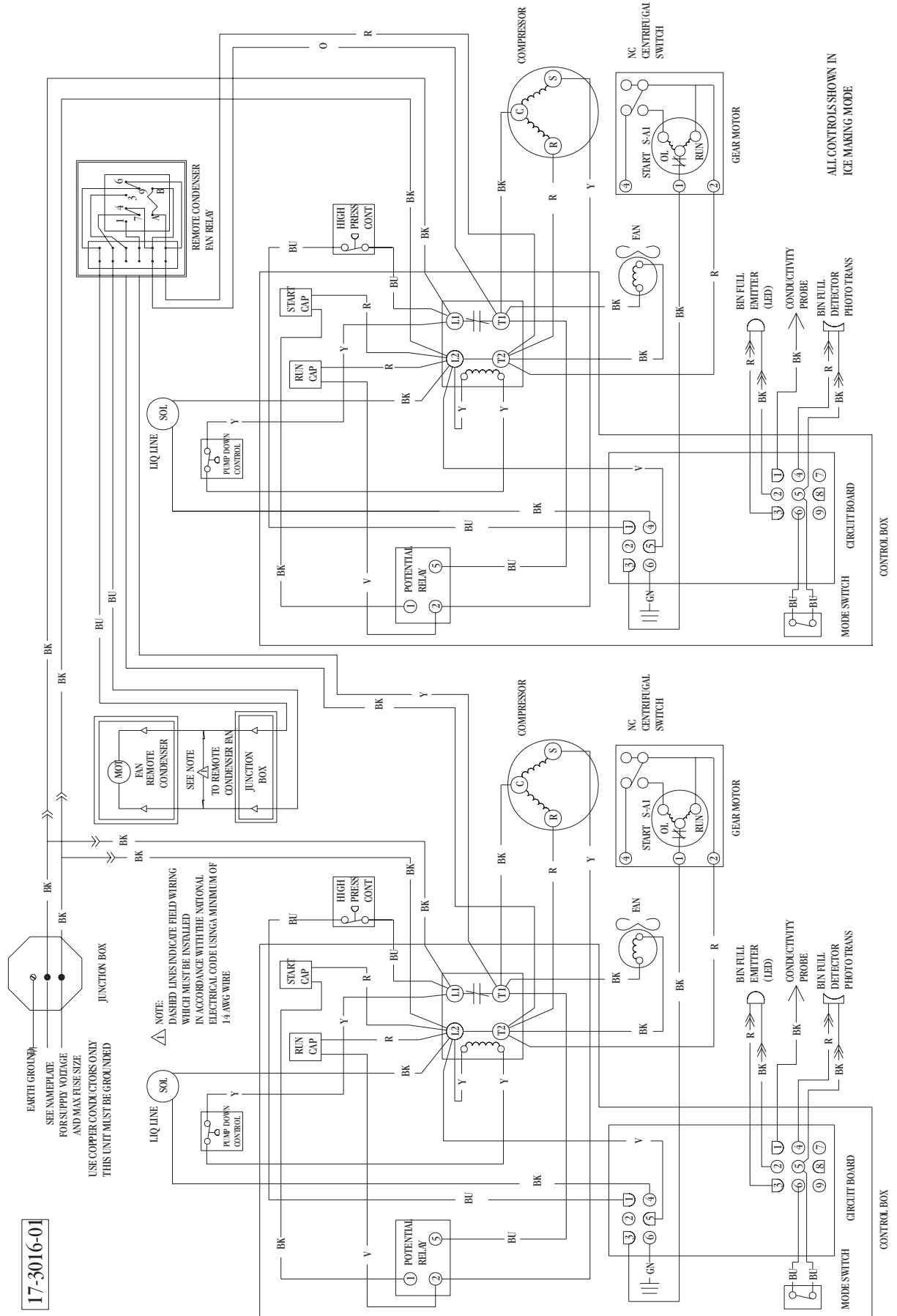

NME1854R & FME2404R SERVICE PARTS

Schematic Diagram 208-230/60/1

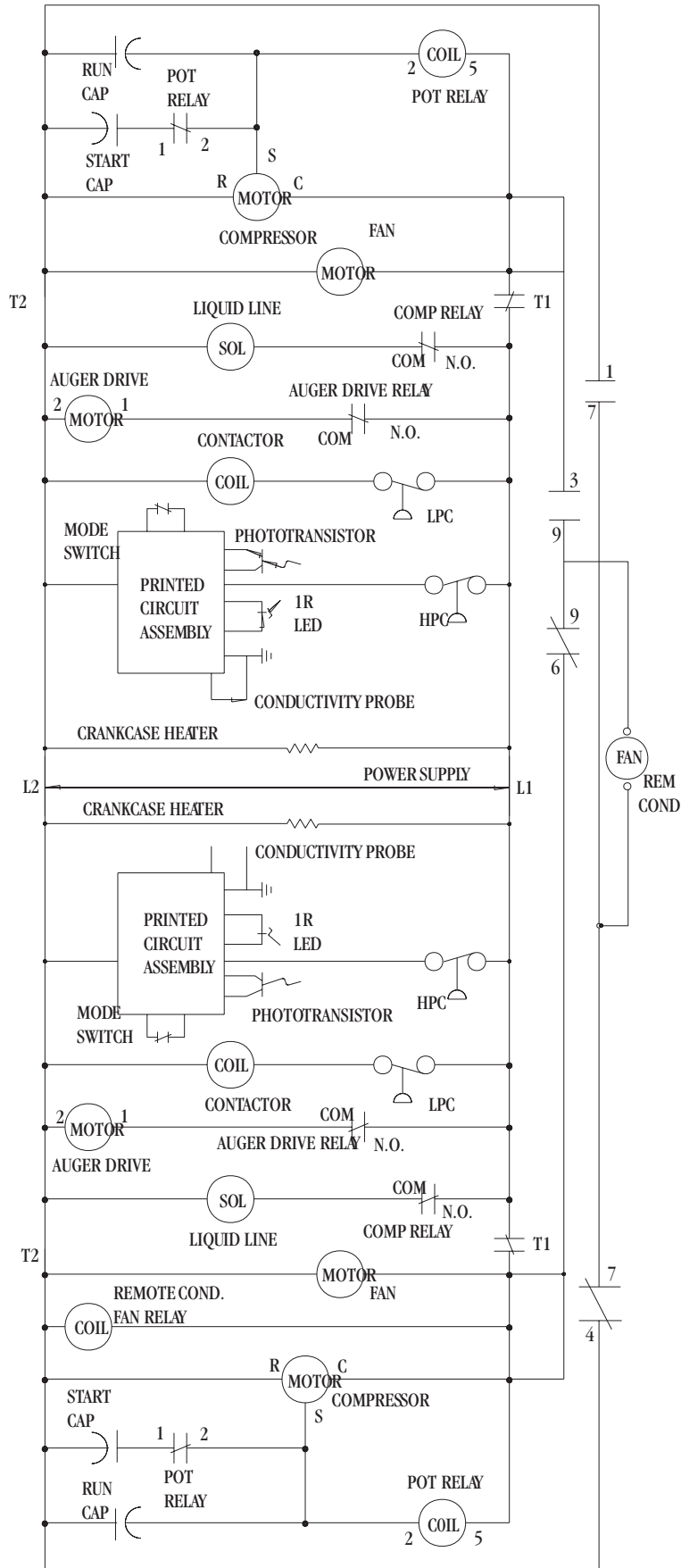

NME1854R & FME2404R SERVICE PARTS

Component Layout Diagram 208-230/60/3

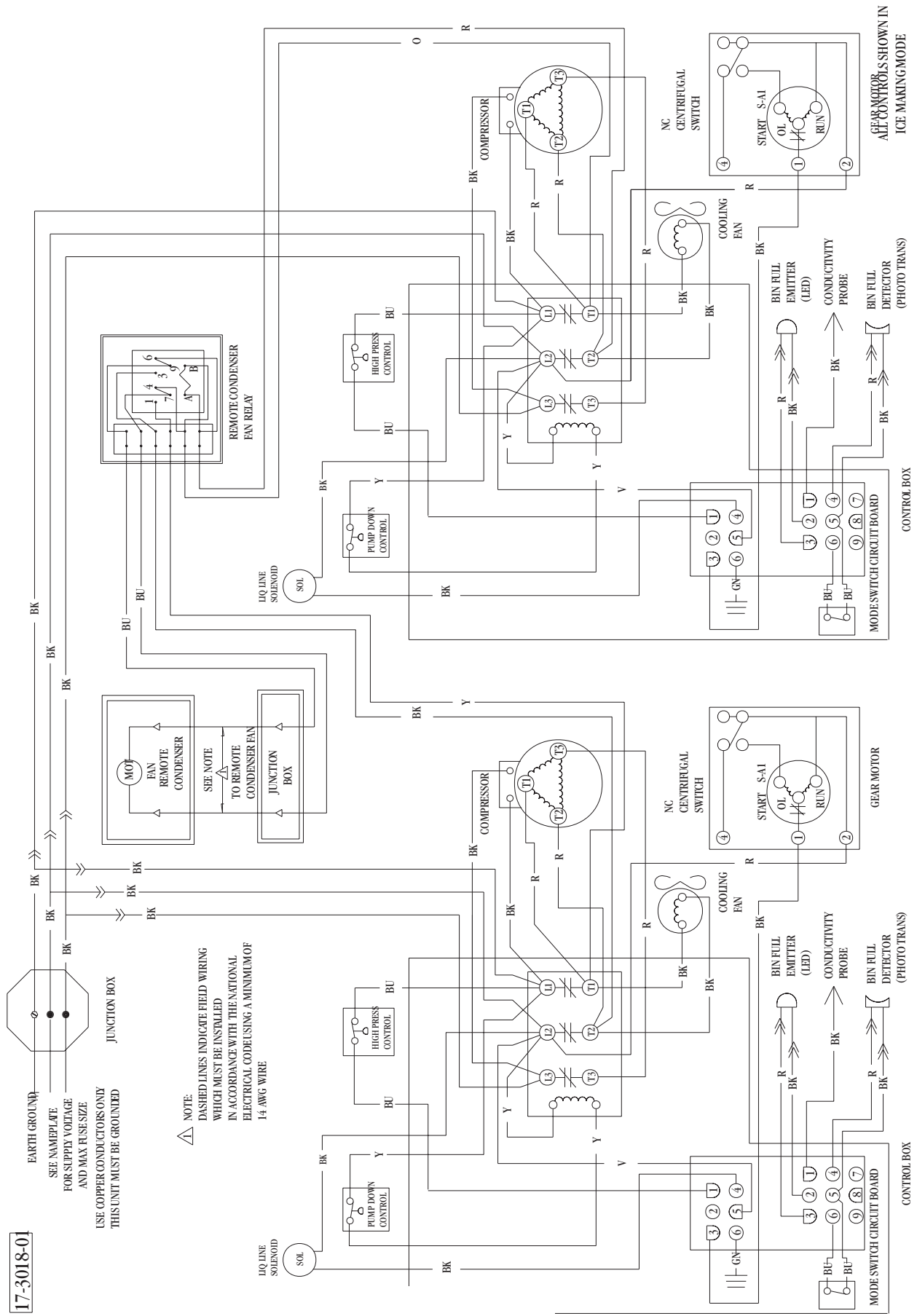

NME1854R & FME2404R SERVICE PARTS

Schematic Diagram 208-230/60/3

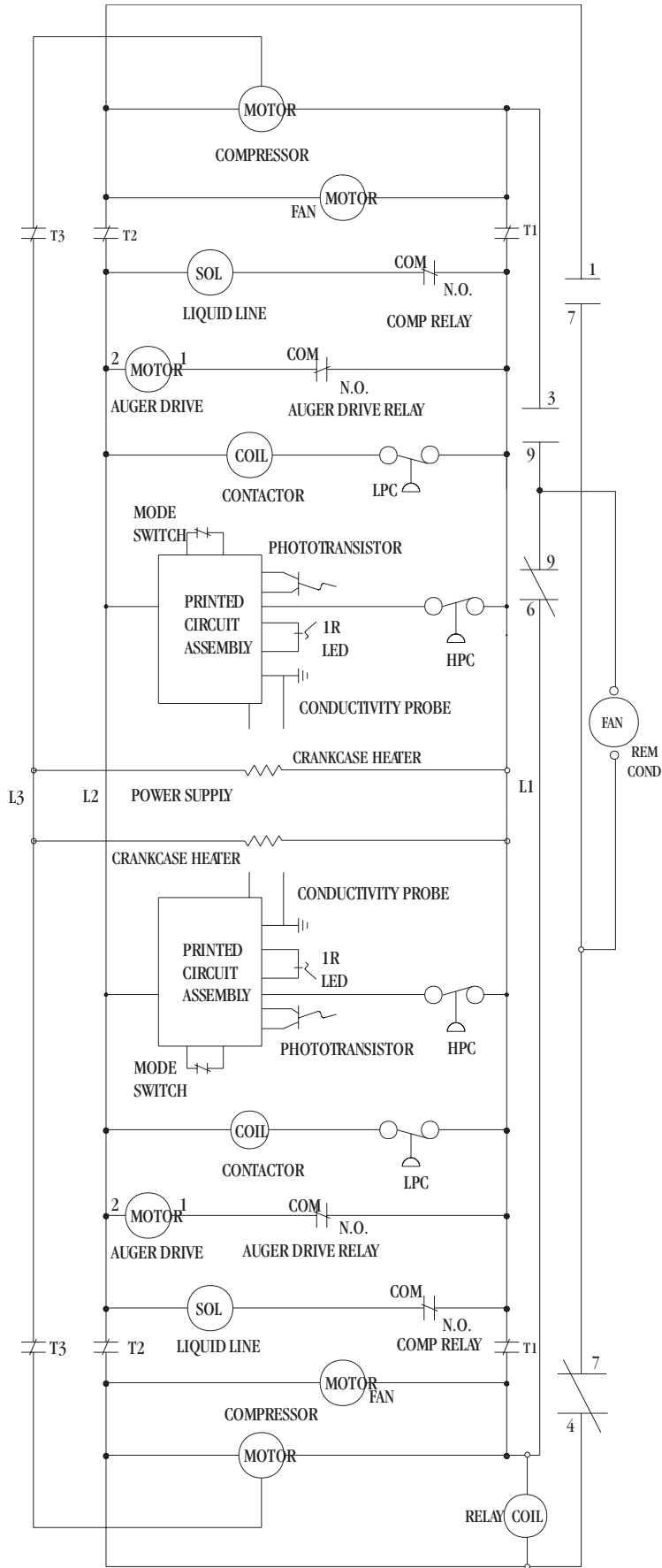

SERVICE BULLETIN

Subject: NME, FME, NSE, NDE and TDE550/650 Top Bearing Lubrication

Two parts have been made available as helpful aids to use when lubricating the top bearing.

1. **02-3559-01** is a needle that snaps onto a standard grease gun fitting. Use it to insert and deeply pack the proper lubricant into the top bearing.
2. **A36808-001** is a tube of the proper lubricant, also designed to fit a standard grease gun.

Both numbers are in the parts price list.

Needle, shown inserted into bearing

