

N0422, F0522, N0622, F0822, N0922, F1222, N1322, F1522 Service Parts

This is the illustrated service parts list for the N0422, F0522, N0622, F0822, N0922, F1222, N1322 and F1522 air cooled, water cooled or remote air cooled ice machine heads.

Several models are listed together, be sure to select the correct part based on the complete model number, including voltage.

Voltage codes:

- -1 = 115/60/1
- -32 = 208-230/60/1
- -3 = 208-230/60/3
- -6 = 230/50/1

A compressor changed resulted in the B series, production started July 2011.

Table of Contents

Exterior, N0422, F0522, N0622, F0822	Page 2
Exterior, N0922, F1222, N1322, F1522	Page 3
Interior Cabinet, Water, and Chute Systems	Page 4
Refrigeration Condensing, Air Cooled	Page 5
Condenser Fan Motor System - N0422, F0522, N0622, F0822	Page 6
Condenser Fan Motor System, N0922, F1222, N1322, F1522	Page 7
Refrigeration Condensing, Water Cooled	Page 8
Refrigeration Condensing, Remote Cooled	Page 9
Remote Condenser - ERC111 or ERC311	Page 10
Nugget Evaporator System, N0422, N0622, N0922, N1322	Page 11
Evaporator System, Flakers F0522, F0822, F1222, F1522	Page 12
Gear Reducer and Motor	Page 13
Electrical & Control Box	Page 14
Compressors	Page 15
Compressor Mounting Hardware	Page 15
Crankcase Heaters	Page 15
Wiring Diagram N0422 and F0522	Page 16
Schematic Diagram N0422 or F0522	Page 17
Wiring Diagram N0622, F0822, N0922, F1222, N1322 or F1522 Single Phase	Page 18
Schematic Diagram N0622, F0822, N0922, F1222, N1322 or F1522 Single Phase	Page 19
Wiring Diagram N0922, F1222, N1322 or F1522 Three Phase	Page 20
Schematic Diagram N0922, F1222, N1322 or F1522 Three Phase	Page 21
Wiring Diagram N0622, F0822, N0922, F1222, N1322 or F1522 Remote Single Phase	Page 22
Schematic Diagram N0622, F0822, N0922, F1222, N1322 or F1522 Remote Single Phase	Page 23
Wiring Diagram N0922, F1222, N1322 or F1522 Remote Three Phase	Page 24
Schematic Diagram N0922, F1222, N1322 or F1522 Remote Three Phase	Page 25
N0622, F0822, N0922 or F1222 50 Hz Wiring Diagram	Page 26

N0422, F0522, N0622, F0822, N0922, F1222, N1322, F1522

Service Parts

Exterior, N0422, F0522, N0622, F0822

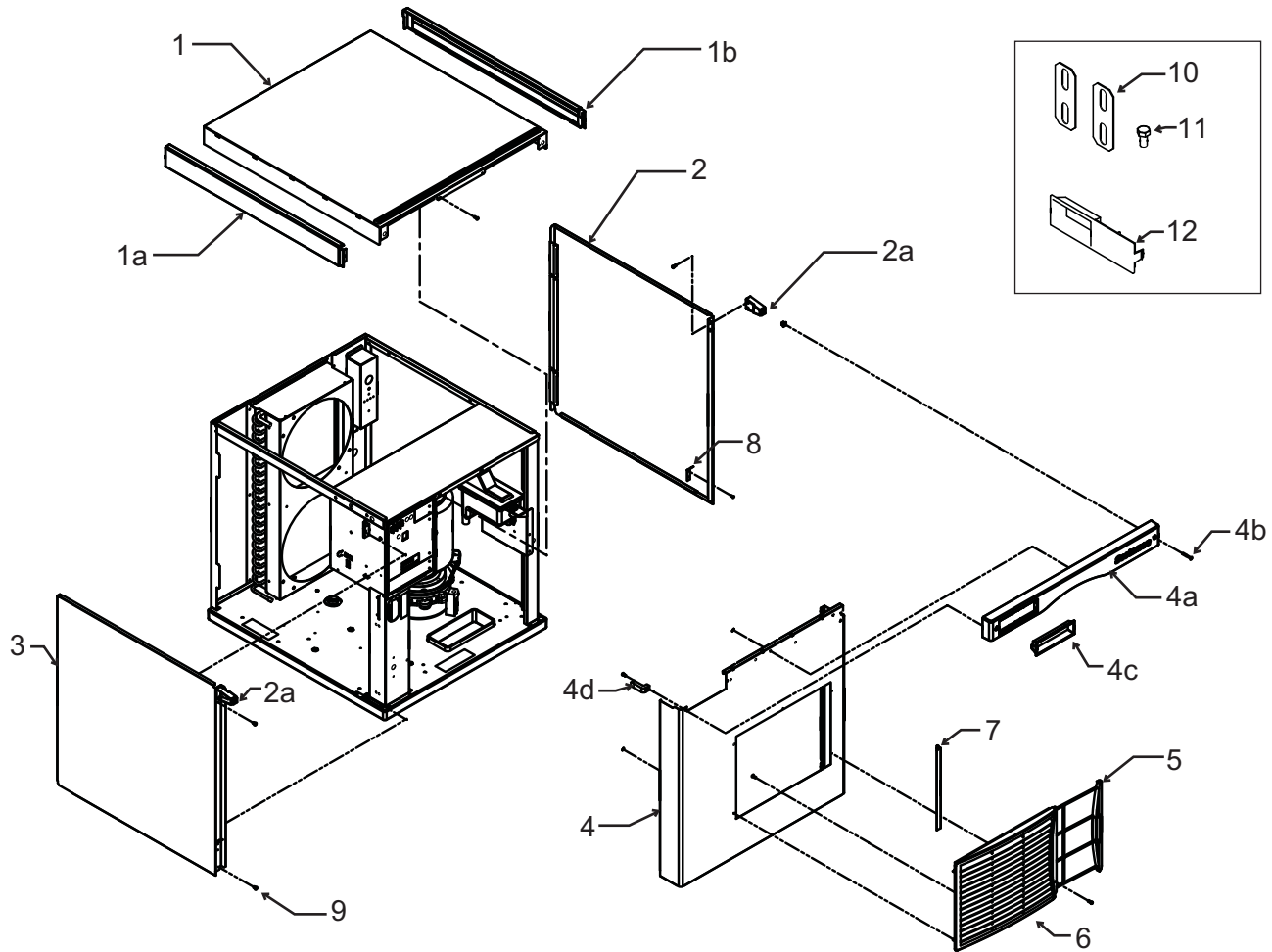

Item Number	Part Number	Description
1	A39579-021	Top panel
1a	02-4221-01	Left trim strip*
1b	02-4221-02	Right trim strip*
2	A39445-021	Right side panel
2a	02-4215-01	Screw receptacle
side panel includes items 2a and 8		
3	A39444-021	Left side panel, AC
	A39444-022	Left side panel, WC, RC
side panel includes items 2a and 8		
4	A39443-021	Front panel, AC
front panel includes items 4a, 4b, 4c, 4d, 5, 6, 7		
	A39443-022	Front panel, WC, RC
front panel includes 4a, 4b, 4c and 4d		
4a	02-4214-01	Trim strip
4b	03-1735-03	Screw
4c	02-4284-01	Bezel
4d	02-4216-01	Gusset
5	02-4212-01	Air filter

6	02-4224-01	Louver bracket
7	A39238-001	Filter bracket
8	A39571-001	Clip
9	03-1404-12	Screw
10	A30911-015	Machine straps
11	03-1405-15	Screw
12	02-4284-02	Bezel, partial window

* Side trim strips discontinued mid 2011

N0422, F0522, N0622, F0822, N0922, F1222, N1322, F1522

Service Parts

Exterior, N0922, F1222, N1322, F1522

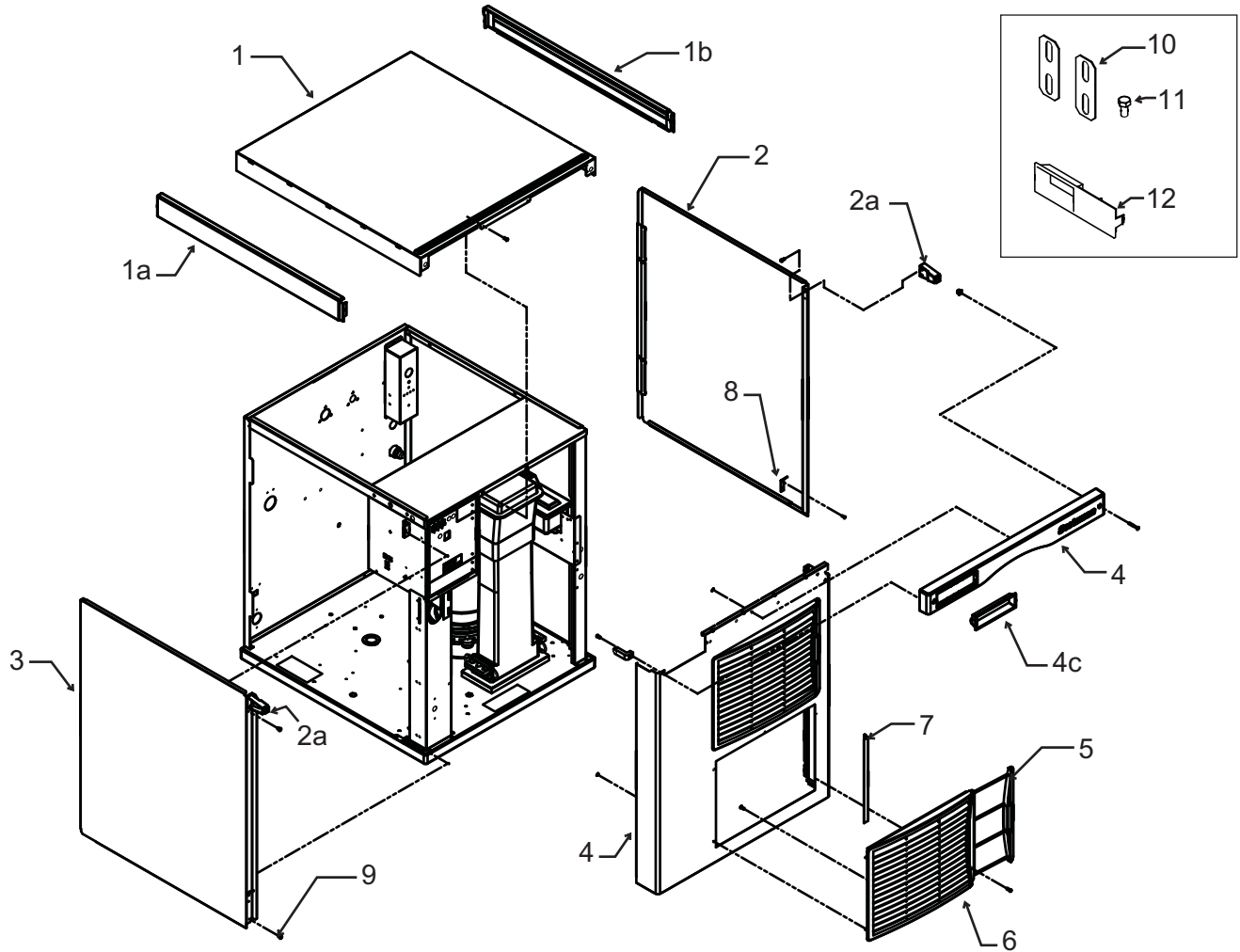

Item Number	Part Number	Description	Item Number	Part Number	Description
1	A39579-021	Top panel	4d	02-4216-01	Gusset
1a	02-4221-01	Left trim strip*	5	02-4212-01	Air filter
1b	02-4221-02	Right trim strip*	6	02-4224-01	Louver bracket
2	A39445-022	Right side panel	7	A39238-001	Filter bracket
2a	02-4215-01	Screw receptacle	8	A39571-001	Clip
side panel includes items 2a and 8			9	03-1404-12	Screw
3	A39444-023	Left side panel, AC	10	A30911-015	Machine straps
	A39444-024	Left side panel, WC, RC	11	03-1405-15	Screw
side panel includes items 2a and 8			12	02-4284-02	Bezel, partial window
4	A39443-023	Front panel, AC	* Side trim strips discontinued mid 2011		
front panel includes items 4a, 4b, 4c, 4d, 5, 6, 7					
	A39443-024	Front panel, WC, RC			
front panel includes 4a, 4b, 4c and 4d					
4a	02-4214-01	Trim strip			
4b	03-1735-03	Screw			
4c	02-4284-01	Bezel			

Service Parts

Interior Cabinet, Water, and Chute Systems

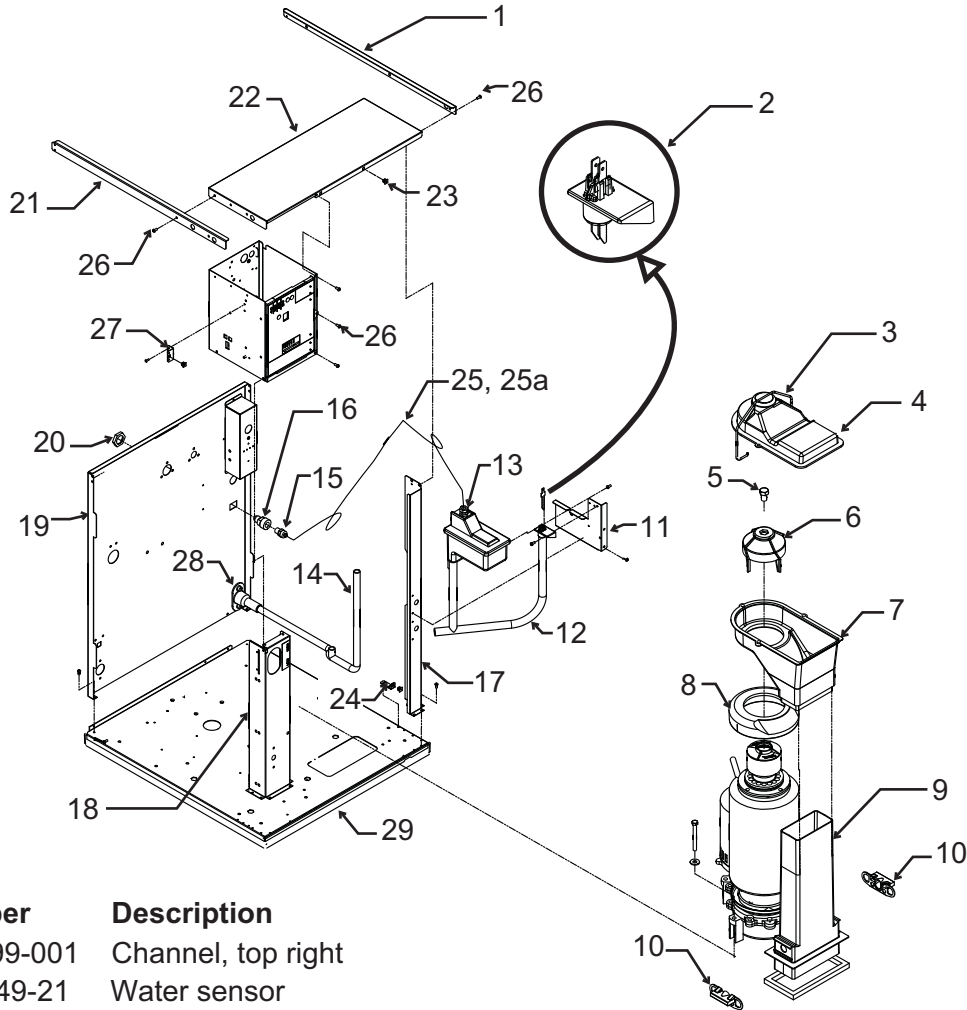

Item Number	Part Number	Description
1	A39199-001	Channel, top right
2	02-4449-21	Water sensor
3	A34969-001	Bail clamp
4	02-2930-04	Chute cover
5	03-1405-52	Cap screw
6	02-3001-01	Ice sweep
7	02-3841-01	Ice chute
8	13-0929-01	Insulation collar, flakers
	13-0929-02	Insulation collar, nuggets
9	02-2929-03	Ice chute lower*
	02-2929-04	Ice chute lower**
10	A37708-021	Bin control set (2)
11	A39200-001	Reservoir bracket
12	A39336-001	Evaporator inlet hose*
	02-4338-01	Evaporator inlet hose**
13	02-3371-01	Water reservoir & valve
13a	02-3371-02	Float and arm only
13b	02-3266-03	Plunger/seat only
14	A39310-001	Drain hose*
	02-4339-01	Drain hose**
15	16-1039-01	Connector, male
16	16-0835-01	Flare fitting, male
17	A39201-001	Post, right front *
	A39182-001	Post, right front **
18	A39196-001	Post, control box*
	A39184-001	Post, control box**
19	A39191-001	Back panel, WC, RC*
	A39194-001	Back panel, WC, RC**
20	03-1394-01	Pal nut
21	A39185-001	Channel, top left
22	A39181-001	Control box cover
23	03-3804-01	Receptacle
24	A38732-001	Panel mount
25	13-0895-01	Tubing, order 3
25a	16-0871-01	Brass insert, at float valve
26	03-1531-01	Screw
27	A39025-001	Bracket
28	02-3692-21	Drain fitting
29	02-4524-21	Base, fits Tecumseh
	02-4524-22	Base, fits Copeland

* for N0422, F0522, N0622, F0822

** for N0922, F1222, N1322, F1522

N0422, F0522, N0622, F0822, N0922, F1222, N1322, F1522
Service Parts

Refrigeration Condensing, Air Cooled

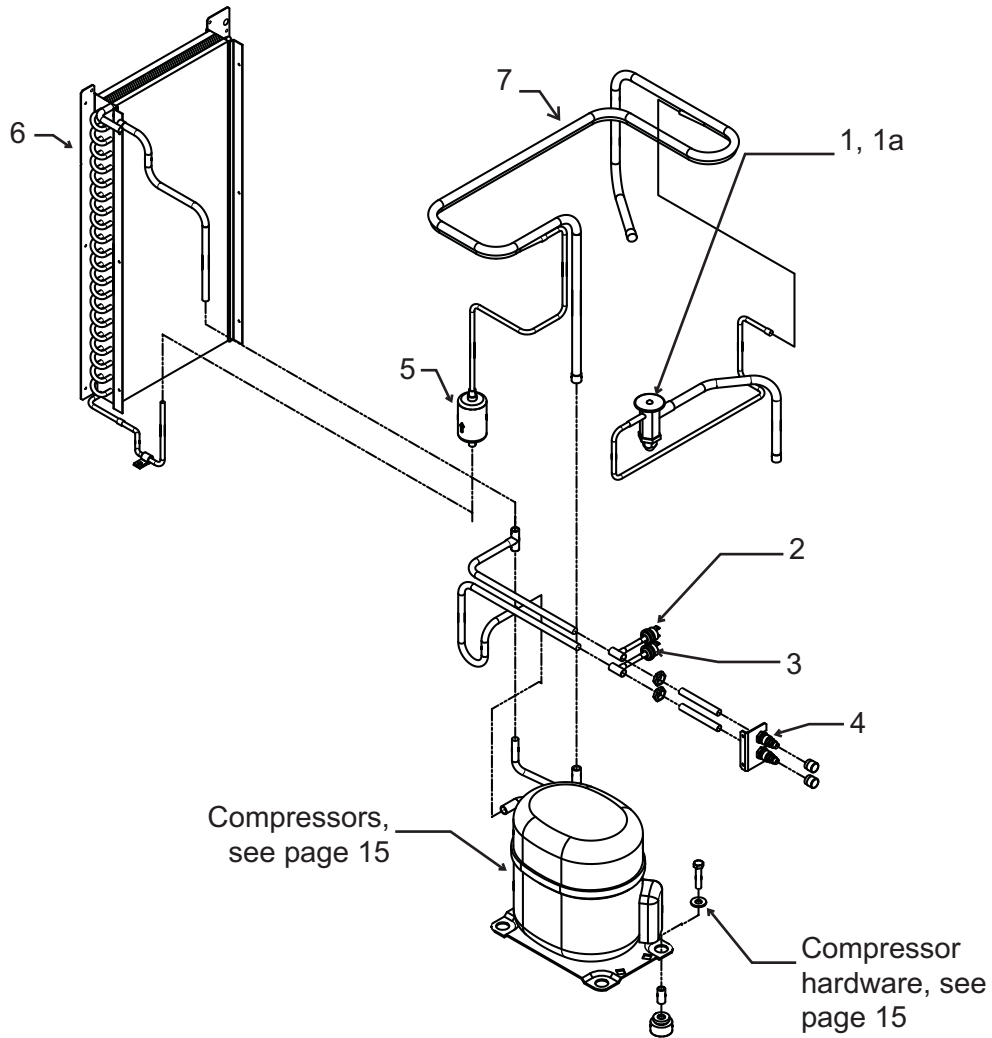

Item Number	Part Number	Description
1	16-1144-21	TXV, N0422, F0522
	16-1144-22	TXV, N0622, F0822
	16-1144-24	TXV, N0922, F1222
	16-1144-23	TXV, N1322, F1522
1a	02-4406-01	Insulation, TXV
2	11-0501-22	High pressure cut out sw
3	11-0502-21	Low pressure cut out sw
4	16-1137-01	Access valve seat
4a	16-1139-01	Access valve core
4b	16-1140-01	Access valve cap
5	02-3319-01	Filter dryer
6	18-8890-01	Air cooled condenser, fits N0422, F0522, N0622, F0822
	18-8935-01	Air cooled condenser, fits N0922, F1222,
	18-8936-01	Air cooled condenser, fits N1322, F1522
7	A39249-001	Suction line for Tecumseh
	A39249-002	Suction line for Copeland

Condenser Fan Motor System - N0422, F0522, N0622, F0822

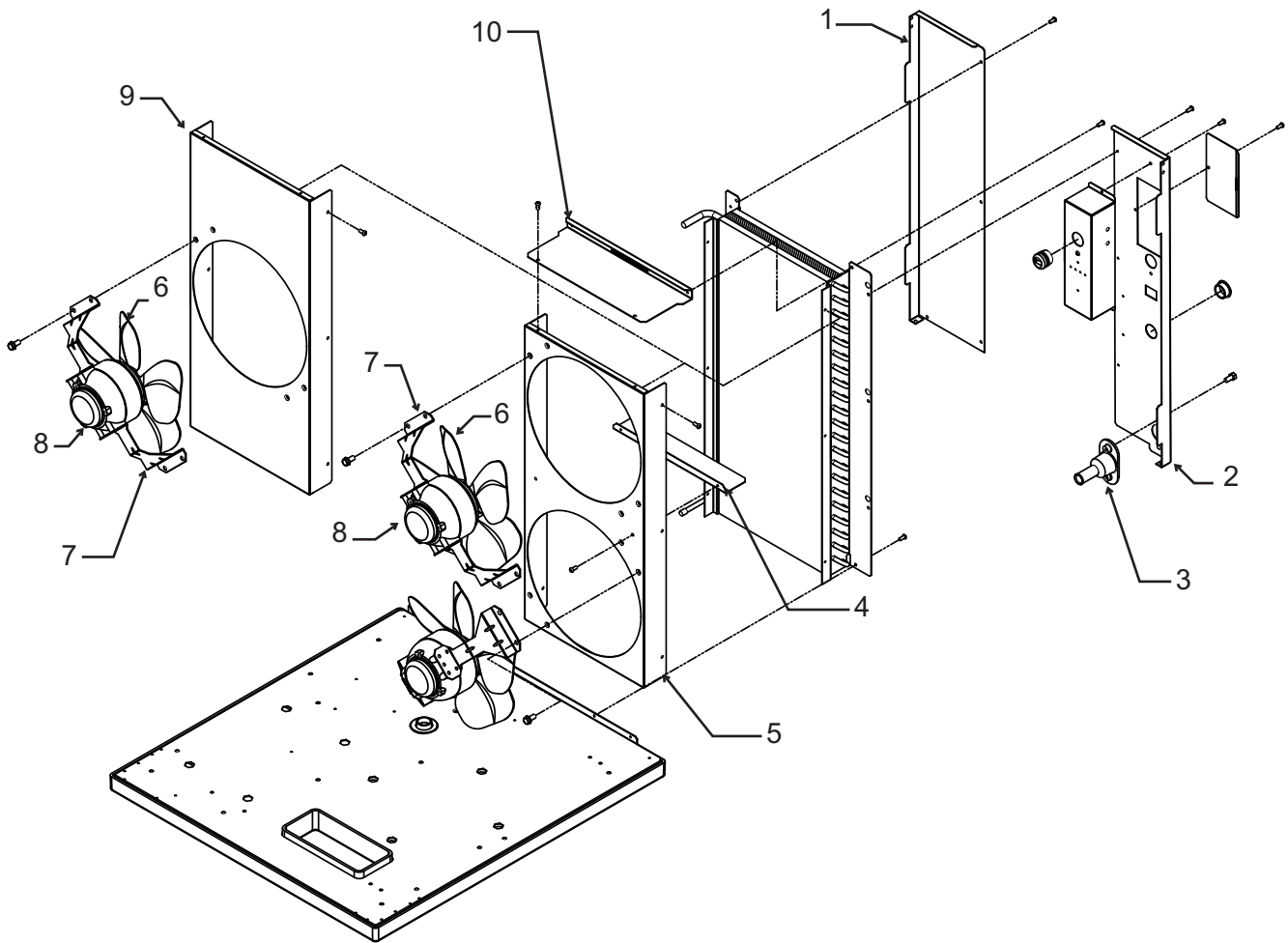

Item Number	Part Number	Description
1	A39186-001	Condenser flange
2	A39187-001	Condenser flange
3	02-3692-21	Drain fitting
4	A38675-001	Shroud divider
5	A39351-001	Shroud, N0622, F0822
6	18-8836-01	Fan blade
7	A38480-001	Bracket, fan motor
8	12-1681-03	Fan motor, 115 volt
	12-1681-04	Fan motor, 208-230 volt/50 or 60 Hz
9	A39350-001	Shroud, N0422, F0522
10	A39352-001	Shroud top

N0422, F0522, N0622, F0822, N0922, F1222, N1322, F1522
Service Parts

Condenser Fan Motor System, N0922, F1222, N1322, F1522

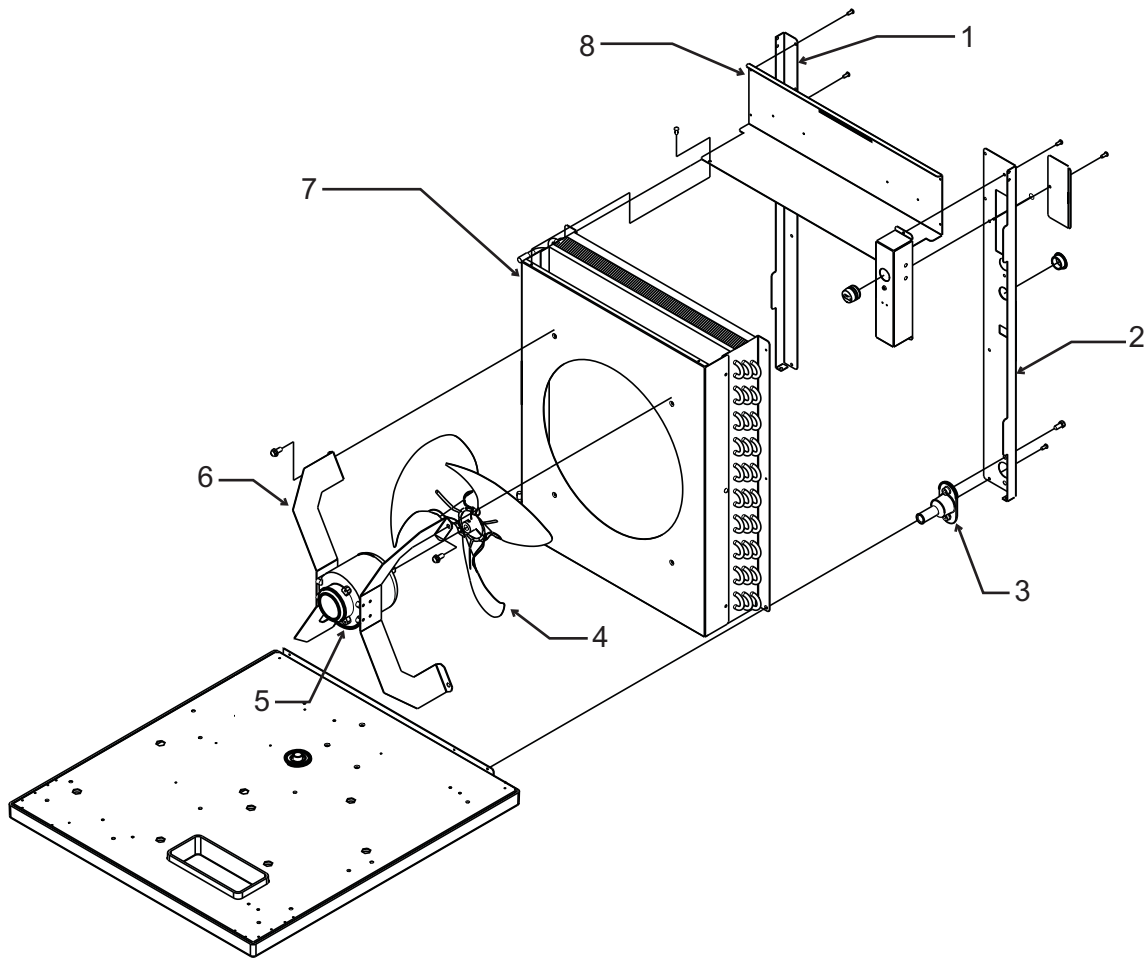

Item Number	Part Number	Description
1	A39188-001	Condenser flange
2	A39189-001	Condenser flange
3	02-3692-21	Drain fitting
4	18-8882-01	Fan blade
5	18-8927-01	Fan motor
6	A39203-001	Bracket, fan motor
7	A39193-001	Shroud
8	A39353-001	Shroud top

Service Parts

Refrigeration Condensing, Water Cooled

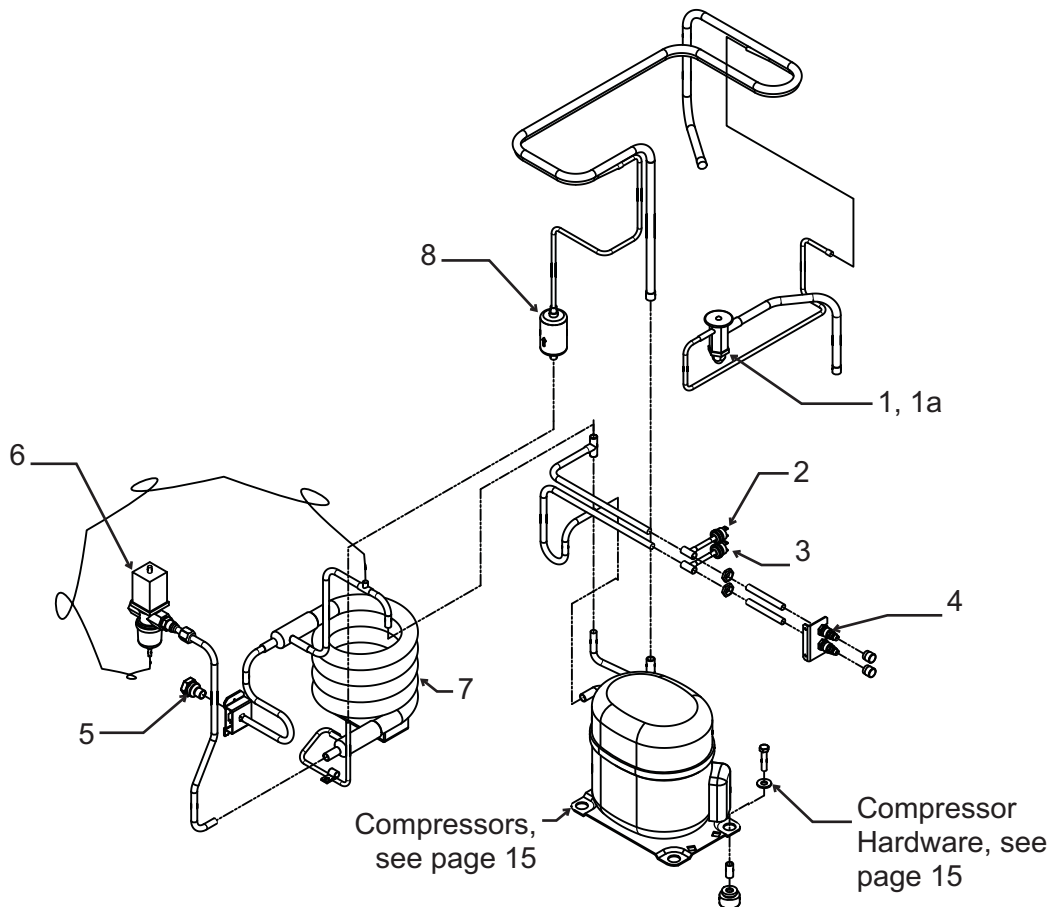

Item Number	Part Number	Description
1	16-1144-21	TXV, N0422, F0522
	16-1144-22	TXV, N0622, F0822
	16-1144-24	TXV, N0922, F1222
	16-1144-23	TXV, N1322, F1522
1a	02-4406-01	Insulation, TXV
2	11-0501-22	High pressure cut out sw
3	11-0502-21	Low pressure cut out sw
4	16-1137-01	Access valve seat
4a	16-1139-01	Access valve core
4b	16-1140-01	Access valve cap
5	16-1154-22	Condenser drain fitting
6	11-0478-01	Water regulating valve
	18-8871-21	Condenser, water cooled fits N0422, F0522, N0622, F0822, N0922, F1222
	18-8893-21	Condenser, water cooled fits N1322 and F1522
	16-0874-01	Receiver, not shown, fits F1222W or N0922W
8	02-3319-02	Filter dryer

Service Parts

Refrigeration Condensing, Remote Cooled

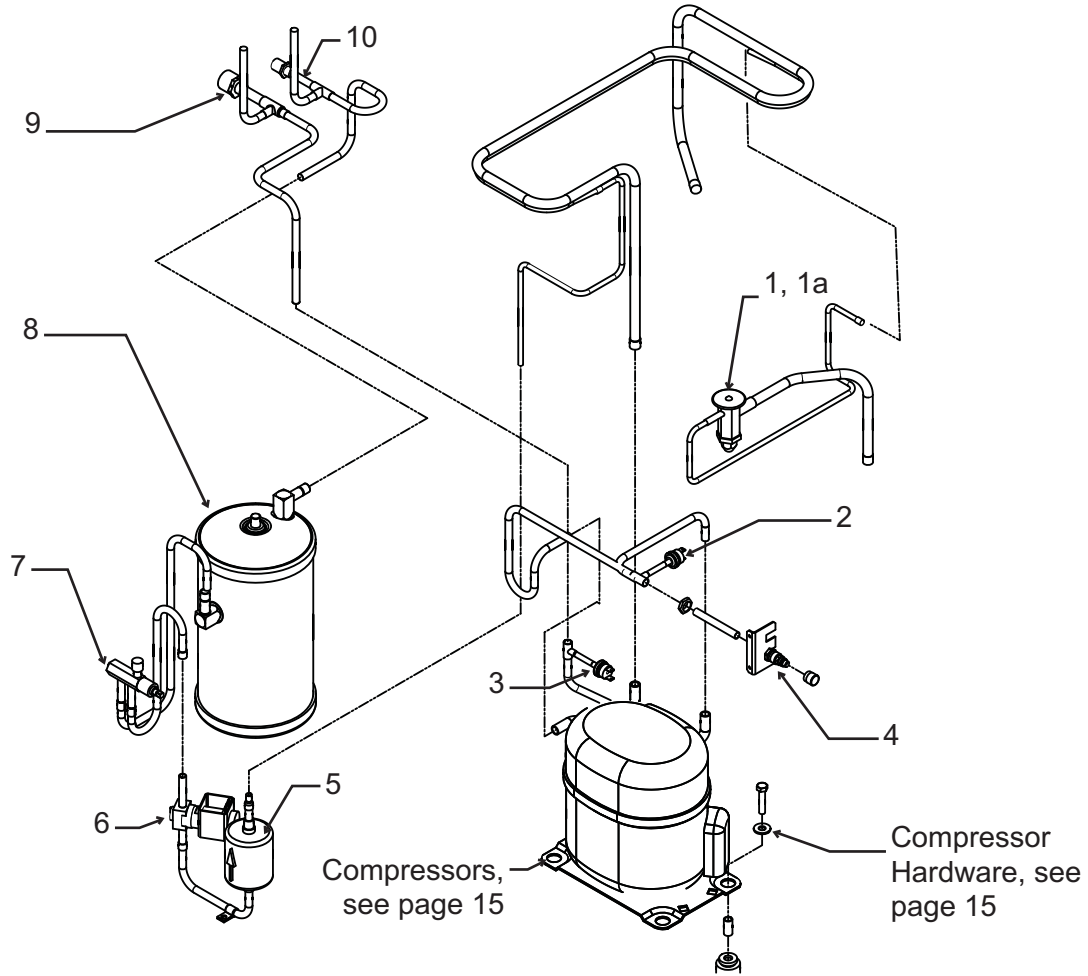

Item Number	Part Number	Description			
1	16-1144-22	TXV, N0622, F0822			
	16-1144-24	TXV, N0922, F1222			
	16-1144-23	TXV, N1322, F1522			
1a	02-4406-01	Insulation, TXV			
2	11-0502-21	Low pressure cut out sw			
3	11-0501-22	High pressure cut out sw			
4	16-1137-01	Access valve seat			
4a	16-1139-01	Access valve core			
4b	16-1140-01	Access valve cap			
5	02-3319-02	Filter dryer			
6	11-0493-01	Liquid line solenoid valve, 208-230 volt, 50/60 Hz			
	12-2719-22	230 volt coil			
	11-0493-02	Liquid line solenoid valve, 115 volt			
	12-2719-21	115 volt coil			
	12-2733-30	LLV/HGV rebuild kit			
7	16-1030-01	Receiver outlet valve			
8	16-1176-01	Receiver			
8a	A37211-001	Bracket, receiver top	9	16-0850-01	Discharge quick connect
8b	A37212-001	Bracket, receiver bottom	10	16-0850-03	Liquid quick connect

Service Parts

Remote Condenser - ERC111 or ERC311

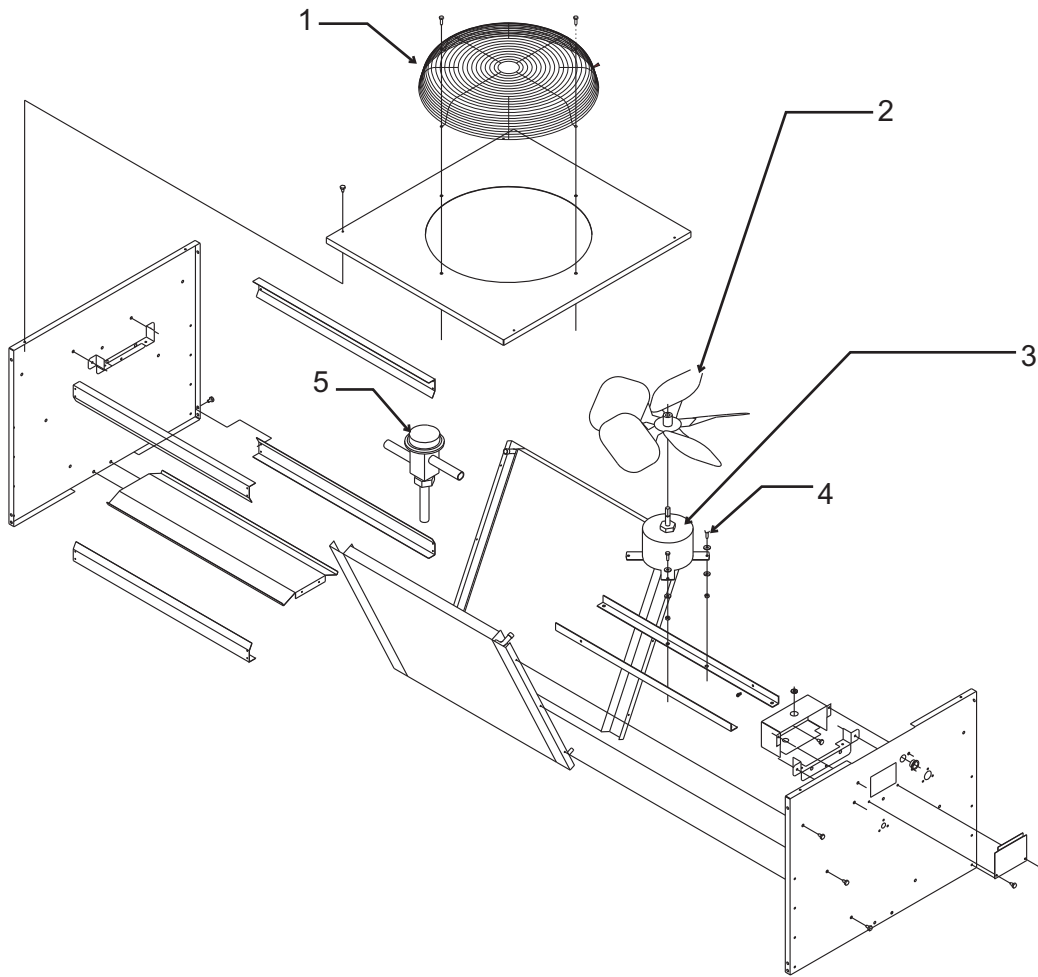

Item Number	Part Number	Description
1	02-3575-01	Fan guard
2	18-8816-01	Fan blade
3	12-2651-01	Fan motor - ERC311 (208-230 volt)
	12-2651-02	Fan motor - ERC111 (115 volt)
4	03-1405-08	Screw
5	11-0422-22	Headmaster

Not shown:

NS1	A37169-001	Leg
NS2	A37170-001	Leg brace
NS3	03-1645-01	Screw for legs
NS4	16-0850-01	Quick disconnect, discharge
NS5	16-0850-03	Quick disconnect, liquid
NS6	16-1057-01	Line set tube end, discharge
NS7	16-1057-02	Line set tube end, liquid

N0422, F0522, N0622, F0822, N0922, F1222, N1322, F1522
Service Parts

Nugget Evaporator System, N0422, N0622, N0922, N1322

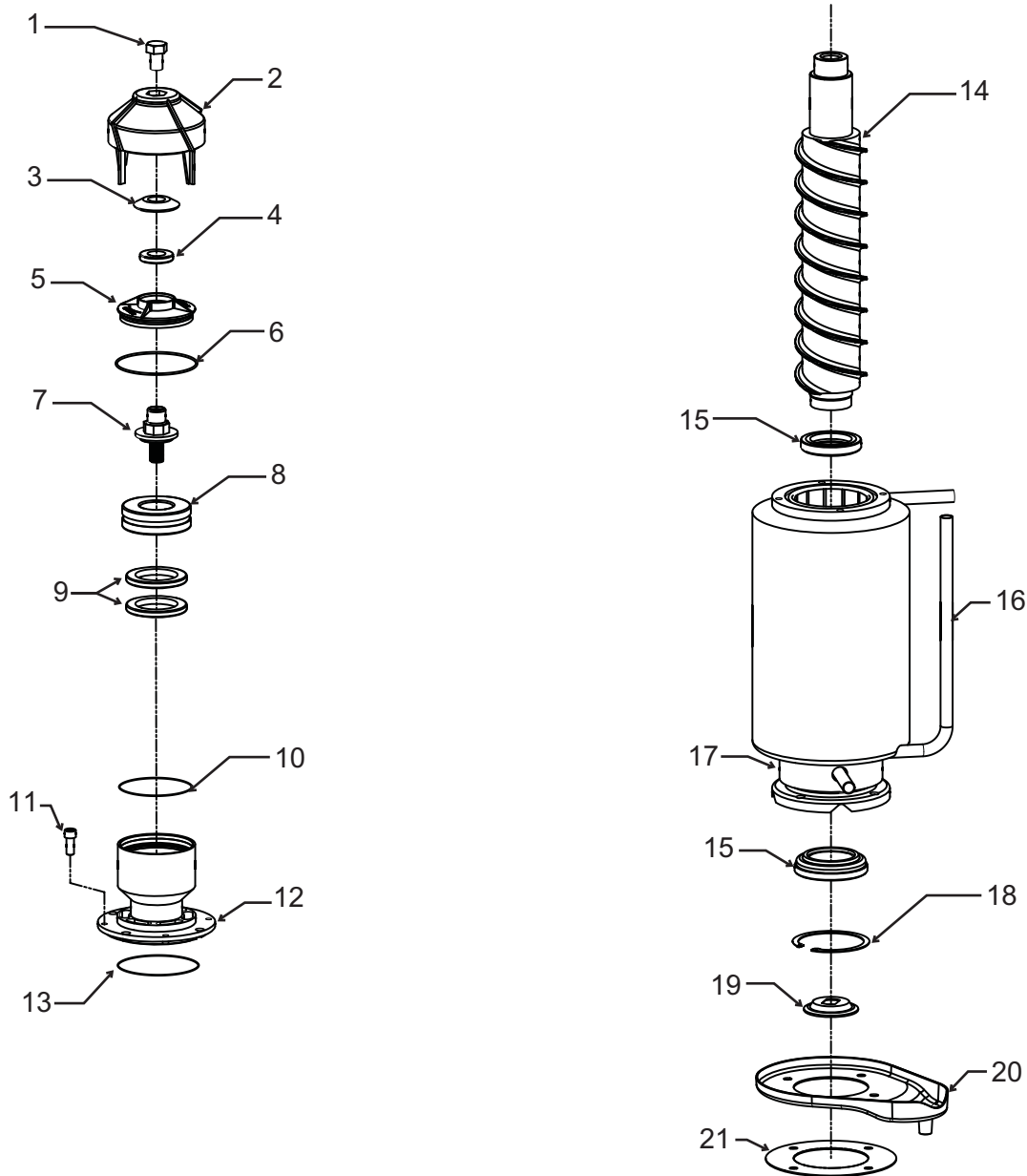

Item Number	Part Number	Description
1	03-1405-52	Cap screw
2	02-3001-01	Ice sweep
3	13-0871-01	Water shed
4	02-2978-01	Lip seal
5	02-3128-20	Cover, includes item 4
6	13-0617-54	O-ring
7	08-0660-01	Auger stud
8	A34559-020	Bearing
9	02-2977-01	Lip seal
10	13-0617-52	O-ring - to chute
11	03-1544-08	Screw, socket head
12	A32900-020	Nugget breaker assembly, includes items 3,4,5,6,8,9 and 13
13	13-0617-45	O-ring
14	A38071-021	Auger, N0422, N0622
	A38071-022	Auger, N0922, N1322
15	02-0929-23	Water seal
16	02-4350-21	Evaporator, N0422, N0622
	02-4352-21	Evaporator, N0922, N1322
16a	03-1405-41	Cap screw to gear box
17	02-4358-01	Collar
18	A32777-001	Retaining ring
19	02-4663-01	Water shed
20	02-3837-01	Drip pan
21	13-0704-00	Gasket

N0422, F0522, N0622, F0822, N0922, F1222, N1322, F1522

Service Parts

Evaporator System, Flakers F0522, F0822, F1222, F1522

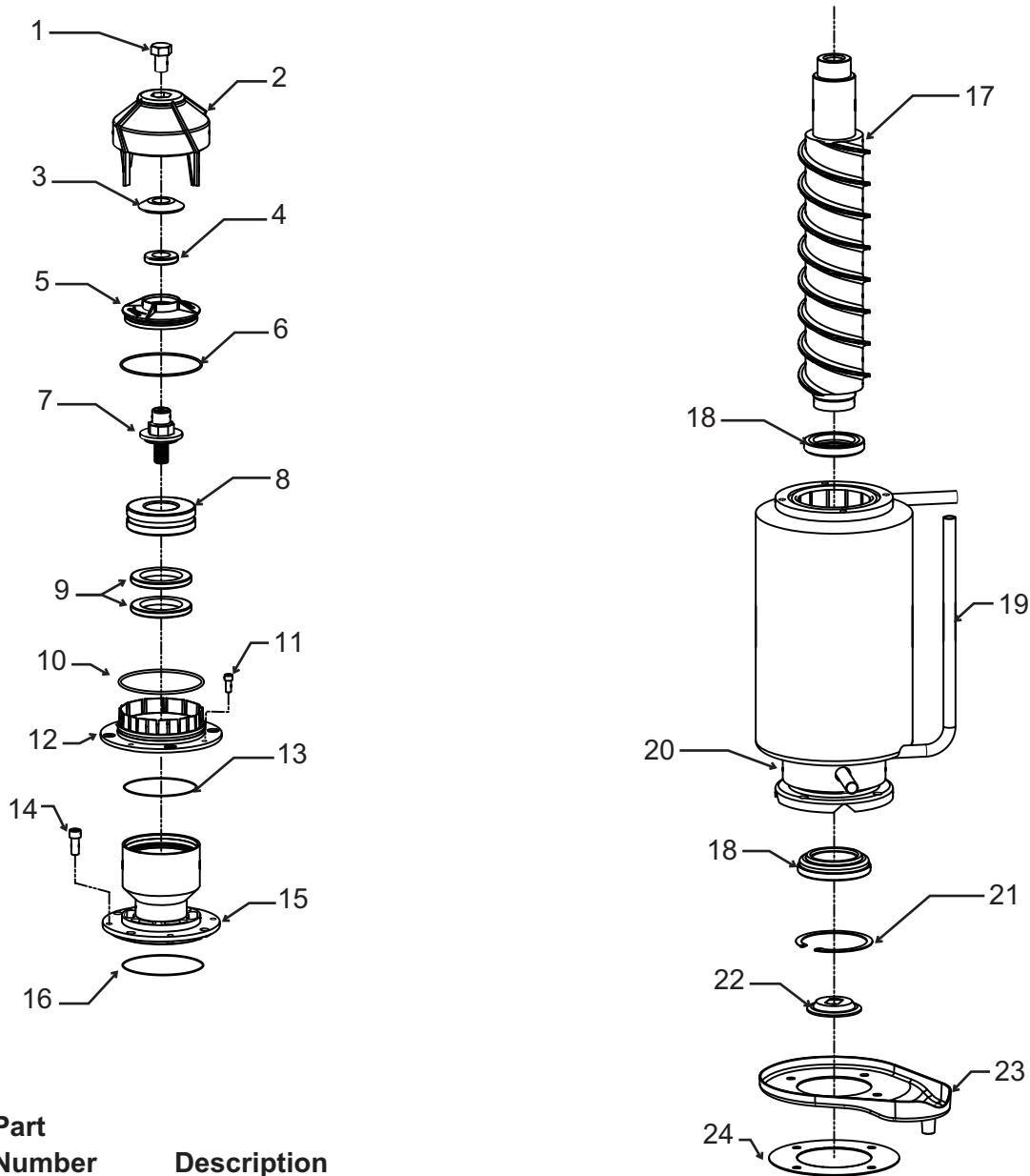

Item Number	Part Number	Description
1	03-1405-52	Cap screw
2	02-3001-01	Ice sweep
3	13-0871-01	Water shed
4	02-2978-01	Lip seal
5	02-3128-20	Cover, includes item 4
6	13-0617-54	O-ring
7	08-0660-01	Auger stud
8	A34559-020	Bearing
9	02-2977-01	Lip seal
10	16-0617-52	O-ring, to chute
11	03-1403-27	Screw
12	02-2916-01	Slotted collar
13	13-0617-49	O-ring, under slotted collar
14	03-1544-08	Screw, socket head
15	A34505-020	Flaker breaker assembly, includes items 3,4,5,6,8,9, and 16
16	03-0617-45	O-ring
17	A38071-021	Auger, F0522, F0822
	A38071-022	Auger, F1222, F1522
18	02-0929-23	Water seal
19	02-4350-21	Evaporator, F0522, F0822
	02-4352-21	Evaporator, F1222, F1522
19a	03-1405-41	Cap screw to gear box
20	02-4358-01	Collar
21	A32777-001	Retaining ring
22	02-4663-01	Water shed
23	02-3837-01	Drip pan
24	13-0704-00	Gasket

Service Parts

Gear Reducer and Motor

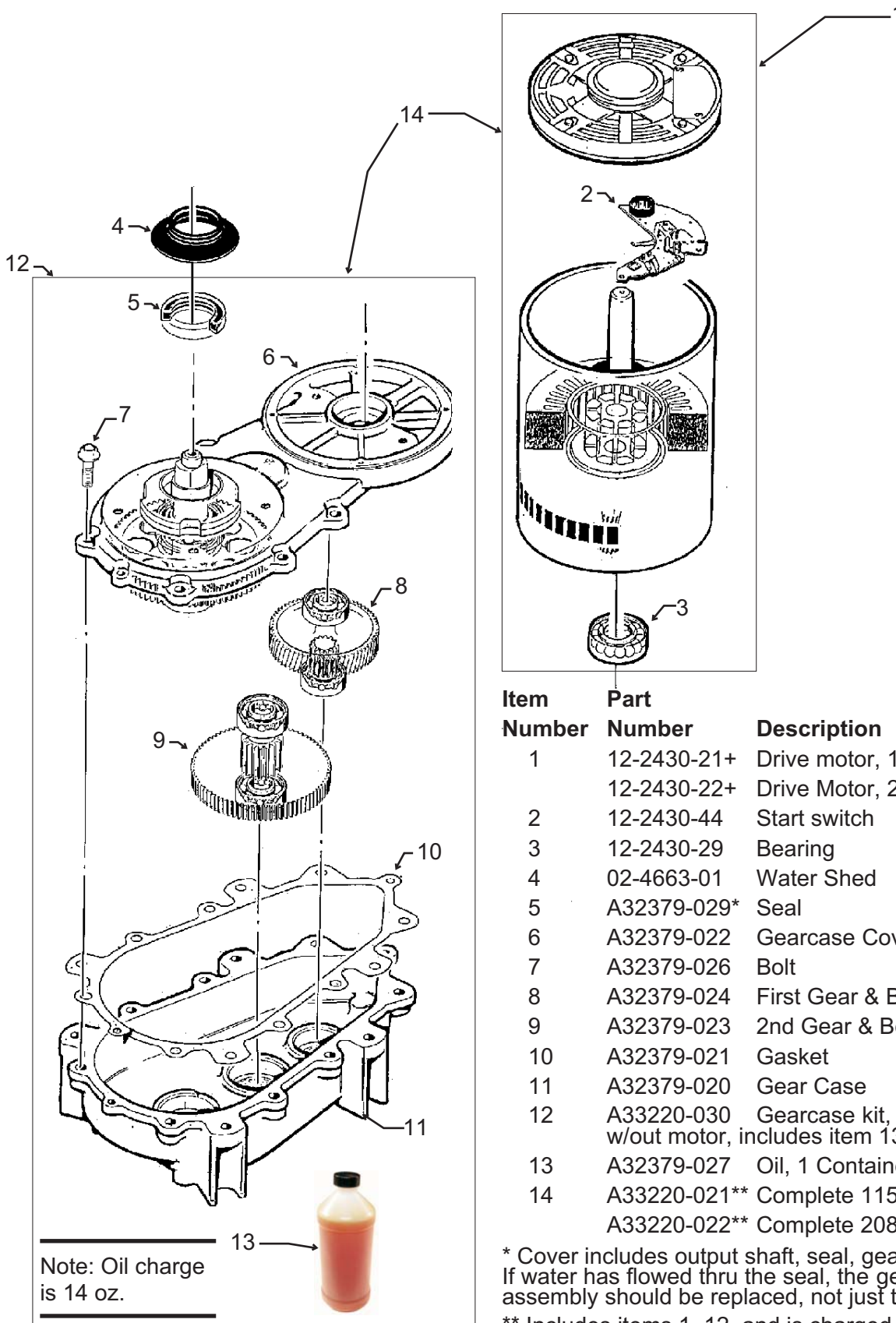

Note: Oil charge is 14 oz.

Item Number	Part Number	Description
1	12-2430-21+	Drive motor, 115 volt
	12-2430-22+	Drive Motor, 208-230 volt
2	12-2430-44	Start switch
3	12-2430-29	Bearing
4	02-4663-01	Water Shed
5	A32379-029*	Seal
6	A32379-022	Gearcase Cover*
7	A32379-026	Bolt
8	A32379-024	First Gear & Bearings
9	A32379-023	2nd Gear & Bearings
10	A32379-021	Gasket
11	A32379-020	Gear Case
12	A33220-030	Gearcase kit, assembled w/out motor, includes item 13
13	A32379-027	Oil, 1 Container
14	A33220-021**	Complete 115 volt
	A33220-022**	Complete 208-230 volt

* Cover includes output shaft, seal, gear and bearings. If water has flowed thru the seal, the gearcase cover assembly should be replaced, not just the seal.

** Includes items 1, 12, and is charged with gear oil.

Service Parts

Electrical & Control Box

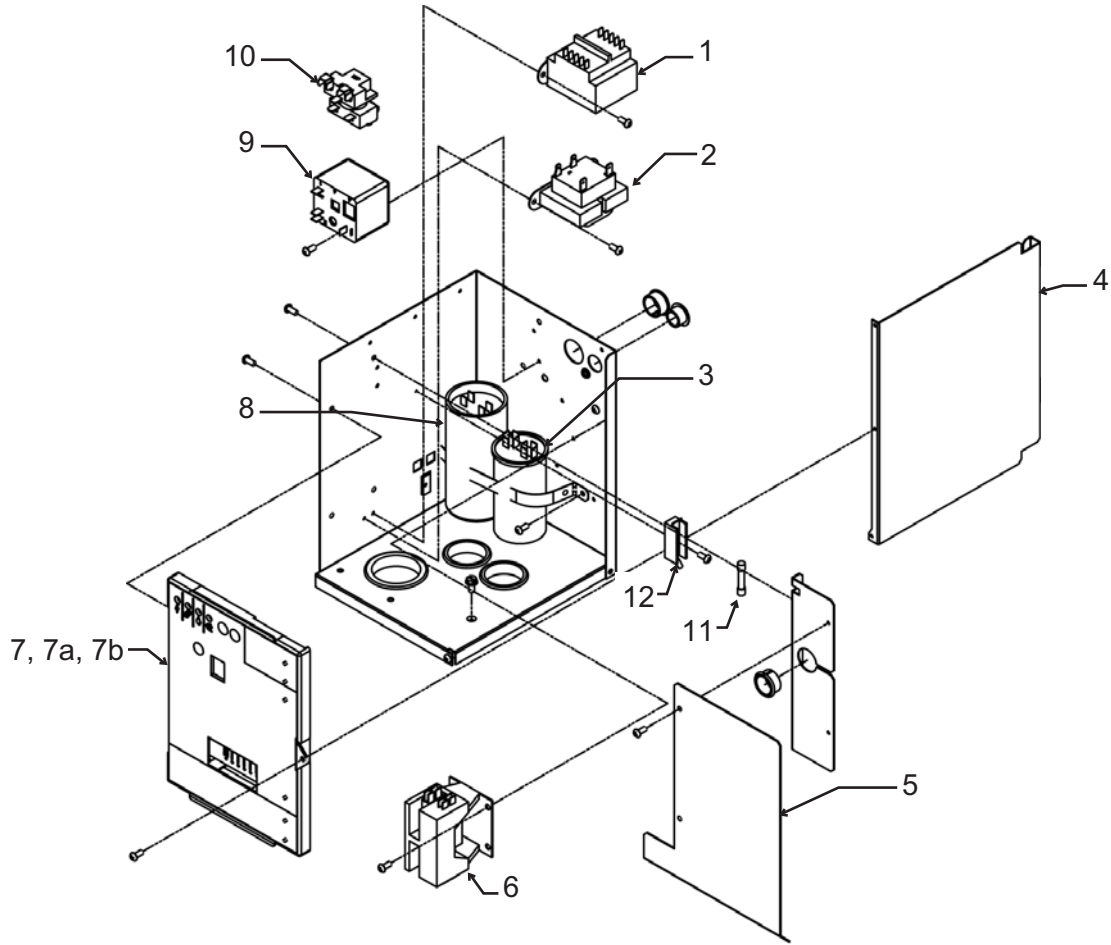

Item Number	Part Number	Description	Harnesses (not shown)		
1	12-2639-01	Transformer, 50 Hz	NS1	12-2976-01	Low voltage harness
2	12-2924-01	Transformer, 115 v	NS2	12-2994-01	High voltage harness, AW
	12-2924-02	Transformer, 208-230 60 Hz	NS3	12-2966-01	High voltage harness, Rem
3	see page 15	Run capacitor			
4	A39198-001	Side cover			
5	A39216-001	Shield			
6	12-2469-03	Contactors, 115 volt			
	12-2469-02	Contactors, 208-230 volt 60 Hz, single phase			
	12-2533-02	Contactors, 3 phase			
7	11-0575-22	Controller			
7a	02-4407-01	Graphic overlay			
7b	02-4076-01	Control box door			
8	see page 15	Start capacitor			
9	see page 15	Potential relay			
10	see page 15	Start relay			
11	12-2686-01	Fuse, 50 Hz only			
12	12-2687-01	Fuse block, 50 Hz only			

N0422, F0522, N0622, F0822, N0922, F1222, N1322, F1522
Service Parts
Compressors

Model	Electrical	Compressor	Overload	Relay	Start Cap	Run Cap
N0422, F0522 -1	115/60/1	18-8929-21	18-8929-23	18-1903-64	18-1901-63	not used
N0622, F0822 -1 A	115/60/1	18-8921-21	18-8921-23	18-1903-68	18-1901-55	18-1902-45
N0622, F0822 -32 A	208-230/60/1	18-8921-22	18-8774-28	18-1903-67	18-1901-56	18-1902-57
N0622, F0822 -6 A	230/50/1	18-8921-26	18-8774-27	18-1903-66	18-1901-56	18-1902-57
N0622, F0822 -1 B*	115/60/1	18-8949-21	18-8949-50	18-1903-44	18-1901-65	18-1902-64
N0622, F0822 -32 B*	208-230/60/1	18-8949-22	18-8949-51	18-1903-54	18-1901-45	18-1902-30
N0622, F0822 -6 B*	230/50/1	18-8949-23	18-8949-52	18-1903-70	18-1901-52	18-1902-65
N0922, F1222 -32	208-230/60/1	18-8922-22	18-8922-27	18-1903-44	18-1901-45	18-1902-57
N0922, F1222 -3	208-230/60/3	18-8813-25	Internal	-	-	-
N0922, F1222 -6	230/50/1	18-8922-26	Internal	18-1903-69	18-1901-64	18-1902-56
N1322, F1522 -32	208-230/60/1	18-8749-22	Internal	18-1903-46	18-1901-48	18-1902-55

* B series production began July 2011

Compressor Mounting Hardware

Model	Bolt	Grommet	Washer	Sleeve
N0422, F0522, N0622, F0822	03-1405-20	18-4700-28	03-1407-07	18-0108-41
N0622, F0822 B	03-1405-20	18-2200-28	03-1407-07	18-2200-27
N0922, F1222 -32	03-1405-20	18-4700-28	03-1407-07	18-0108-41
N0922, F1222 -3	03-1405-20	18-2300-27	03-1407-07	18-2300-26
N1322, F1522 -32	03-1405-20	18-2300-27	03-1407-07	18-2300-26

Crankcase Heaters

Model	Series	Voltage	Heater
N0622R-1, F0822R-1	A	115	12-2942-01
N0622R-32, F0822R-32	A	230	12-2942-02
N0622R-1, F0822R-1	B	115	12-3043-01
N0622R-32, F0822R-32	B	230	12-3043-02
N0922R-32, F1222R-32	A	230	12-2942-02
N0922R-3, F1222R-3	A	230, 3 phase	18-2308-01
N1322R -32, -3, F1522R-32, -3	A	230	18-2308-01

N0422, F0522, N0622, F0822, N0922, F1222, N1322, F1522

Service Parts

Wiring Diagram N0422 and F0522

17-3211-01

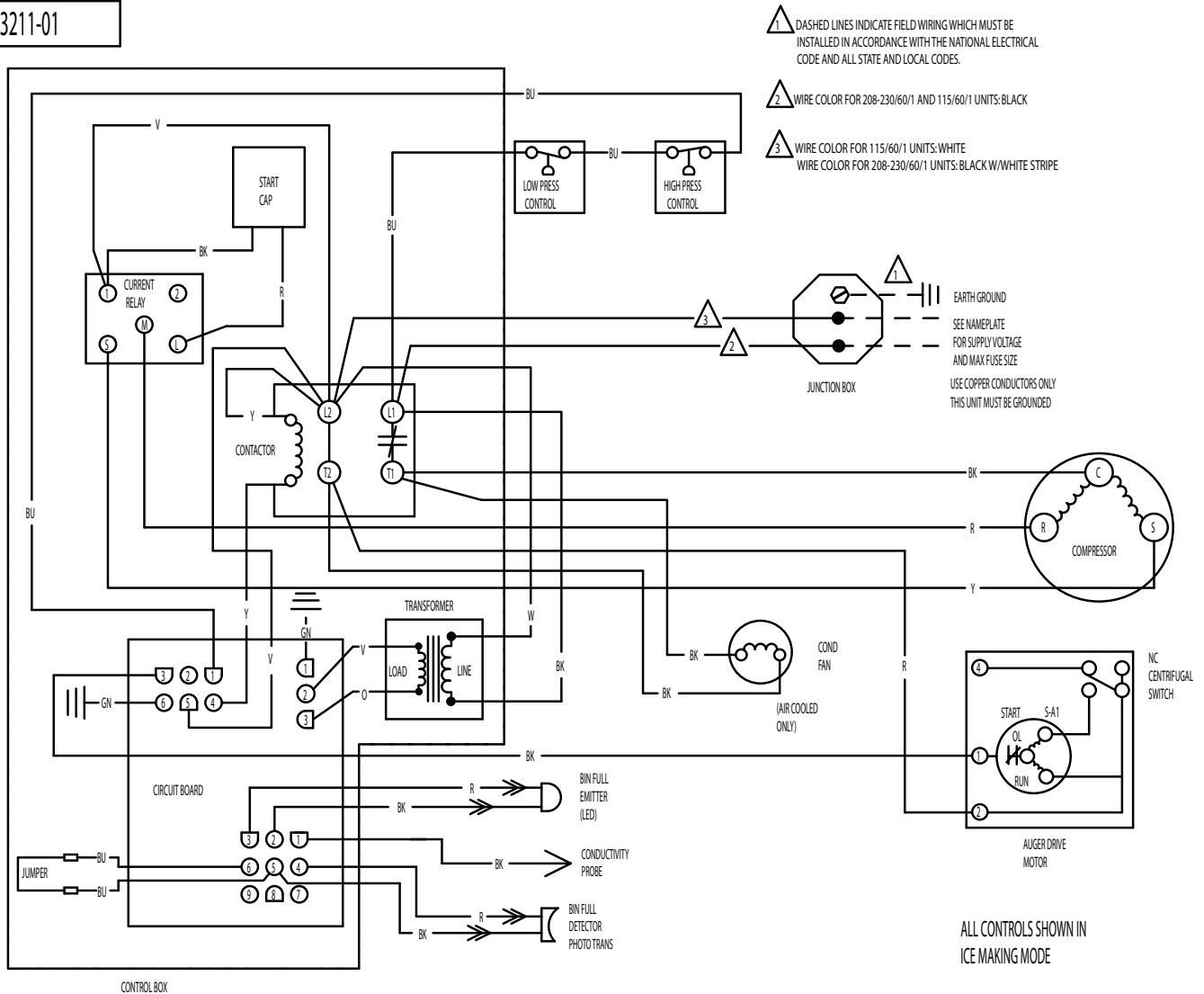

N0422, F0522, N0622, F0822, N0922, F1222, N1322, F1522
 Service Parts

Schematic Diagram N0422 or F0522

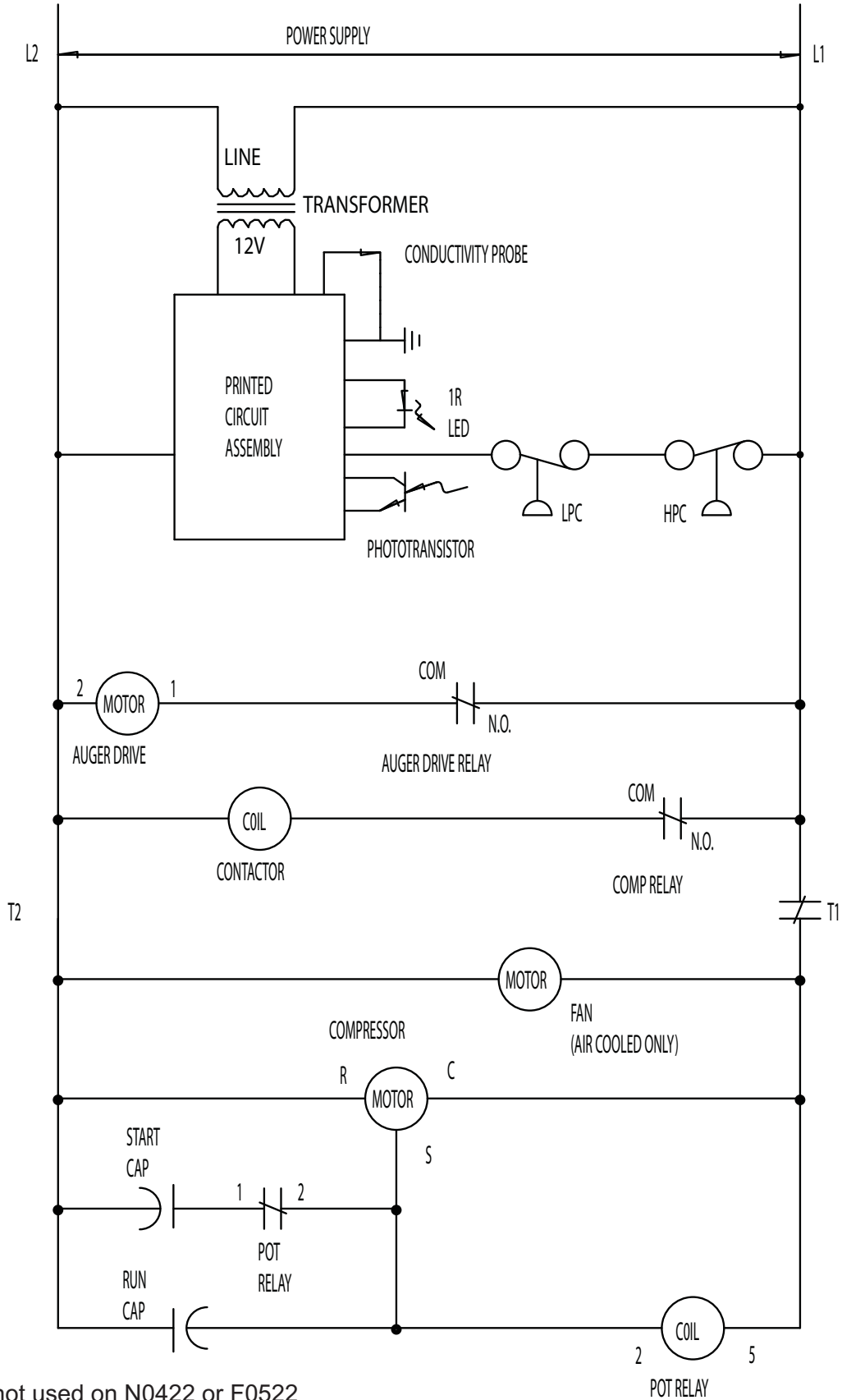

Run Cap not used on N0422 or F0522

Wiring Diagram N0622, F0822, N0922, F1222, N1322 or F1522 Single Phase

17-3199-01

CAUTION:
MORE THAN ONE DISCONNECT MEANS MAY BE
REQUIRED TO DISCONNECT ALL POWER TO THIS UNIT.

⚠ DASHED LINES INDICATE FIELD WIRING WHICH MUST BE
INSTALLED IN ACCORDANCE WITH THE NATIONAL ELECTRICAL
CODE AND ALL STATE AND LOCAL CODES.

⚠ WIRE COLOR FOR 208-230/60/1 AND 115/60/1 UNITS: BLACK

⚠ WIRE COLOR FOR 115/60/1 UNITS: WHITE
WIRE COLOR FOR 208-230/60/1 UNITS: BLACK W/WHITE STRIPE

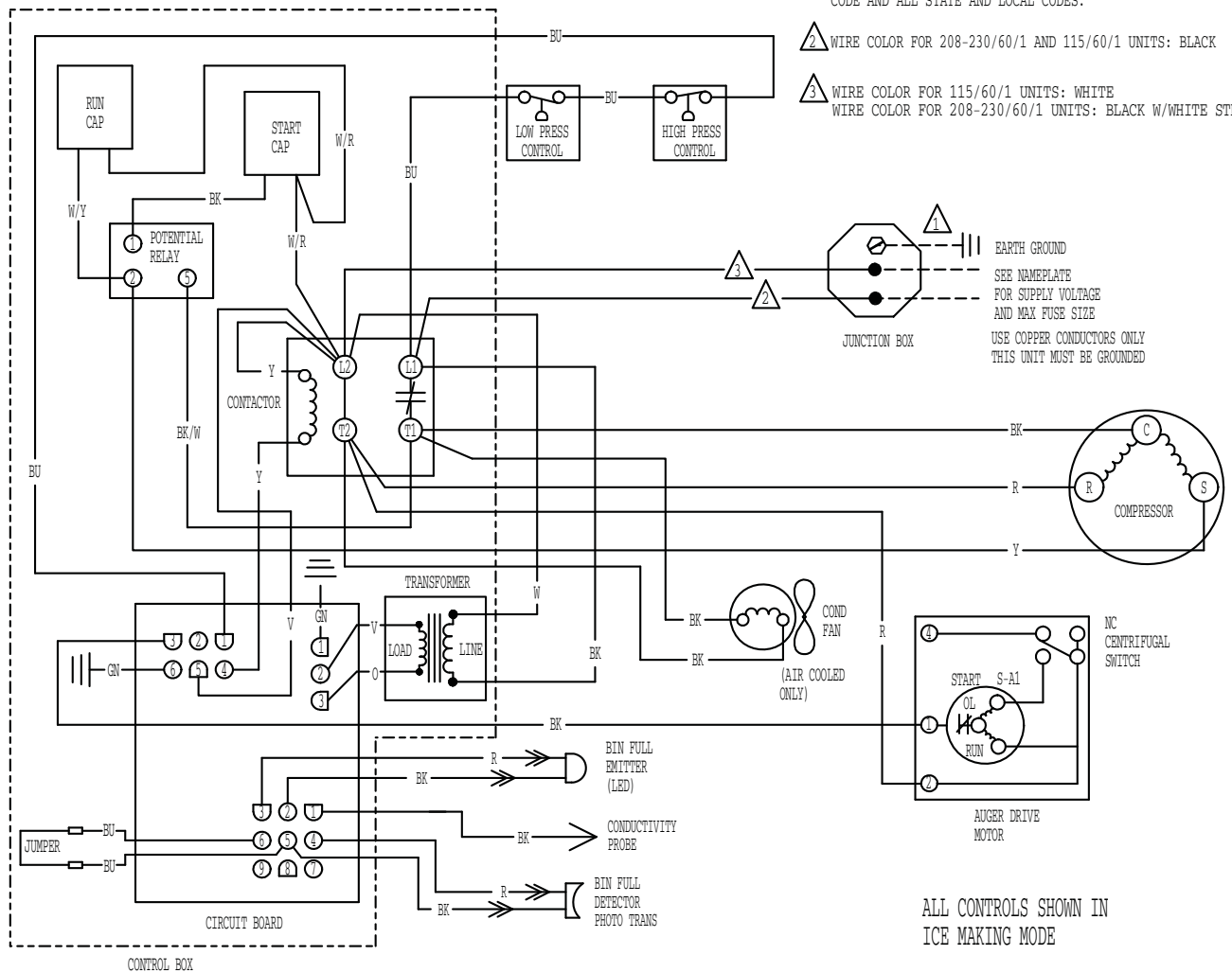

N0422, F0522, N0622, F0822, N0922, F1222, N1322, F1522
 Service Parts

Schematic Diagram N0622, F0822, N0922, F1222, N1322 or F1522 Single Phase

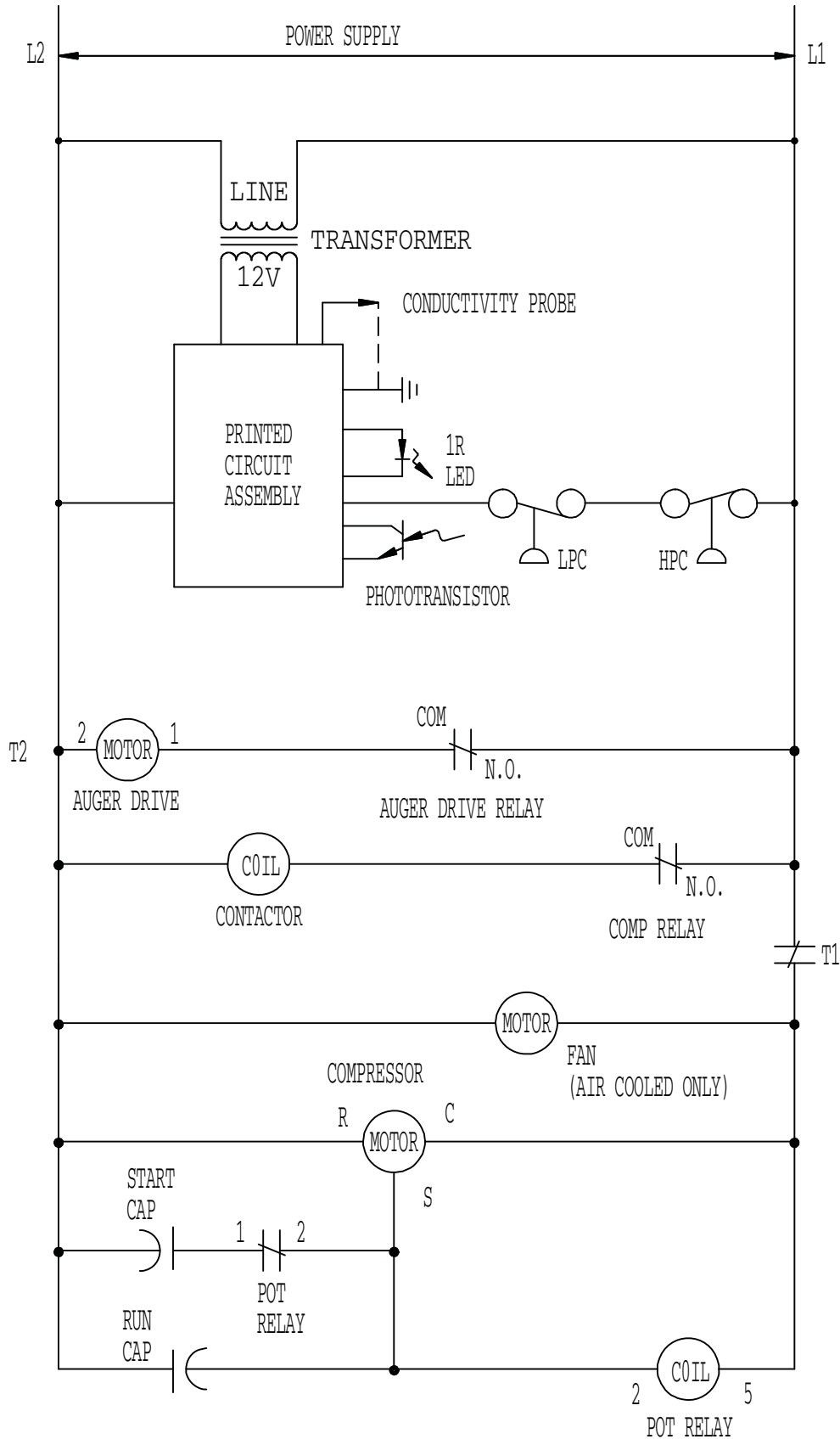

N0422, F0522, N0622, F0822, N0922, F1222, N1322, F1522

Service Parts

Wiring Diagram N0922, F1222, N1322 or F1522 Three Phase

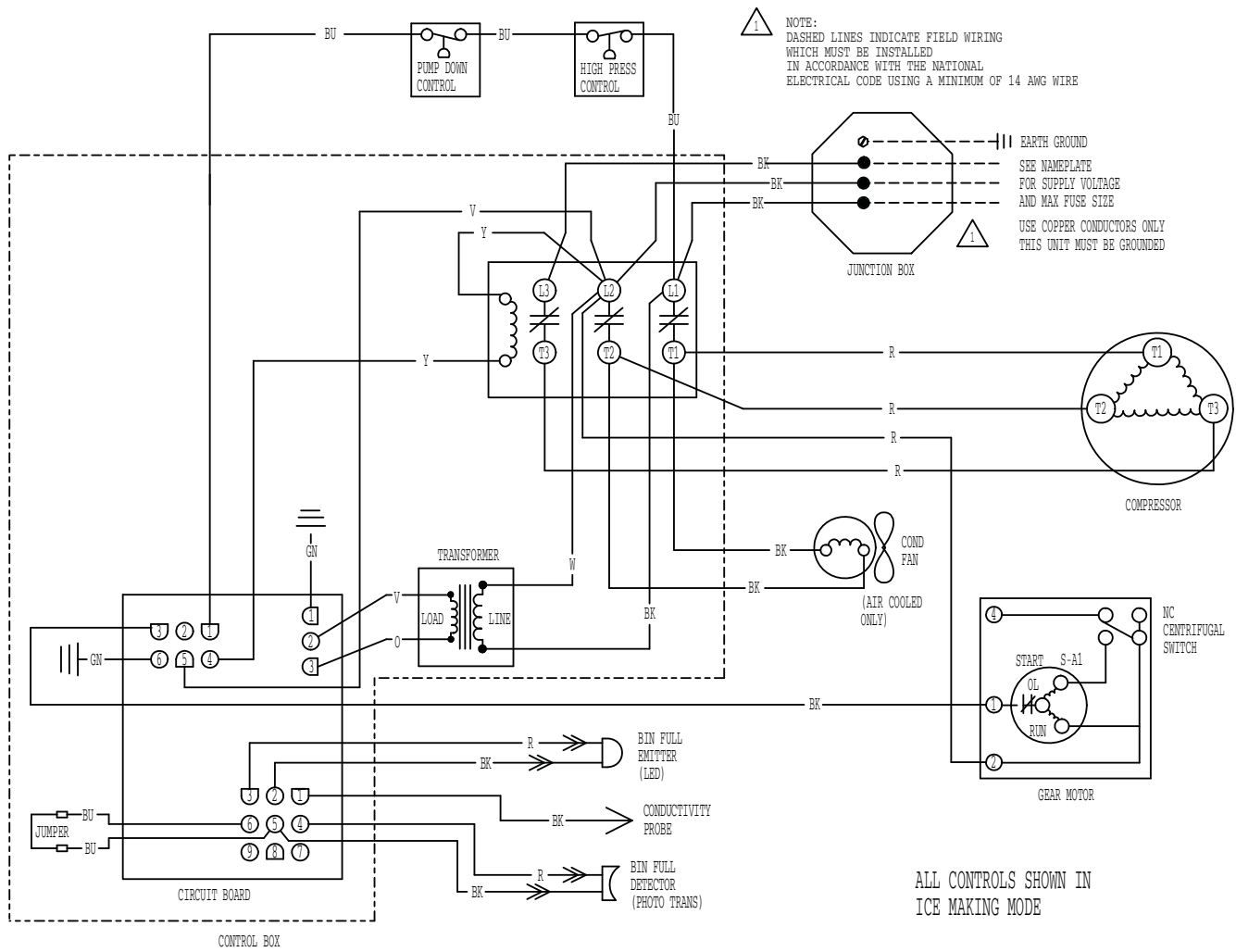

N0422, F0522, N0622, F0822, N0922, F1222, N1322, F1522
 Service Parts

Wiring Diagram N0622, F0822, N0922, F1222, N1322 or F1522 Remote Single Phase

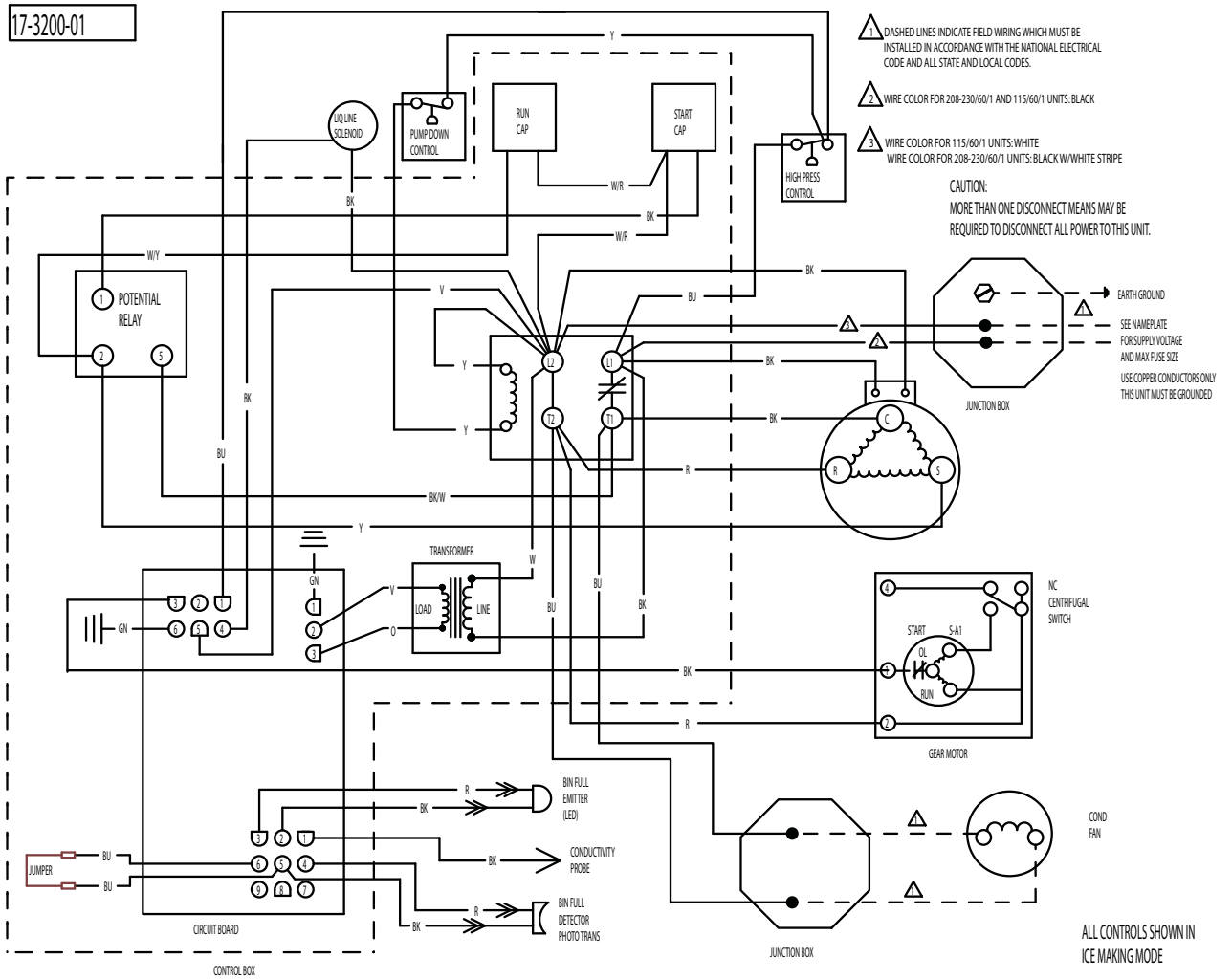

N0422, F0522, N0622, F0822, N0922, F1222, N1322, F1522

Service Parts

Wiring Diagram N0922, F1222, N1322 or F1522 Remote Three Phase

