

# RL Single System SERVICE PARTS

This parts list contains the service parts and wiring diagrams for the following models:

- FME1202RL
- NME952RL
- FM1202RL
- NM952RL
- FME1500RL
- NME1250RL

Check the model number of the machine requiring the parts to be sure that this is the correct parts list.

## TABLE OF CONTENTS

Cabinet Assembly . . . . .	Page 2
Water System . . . . .	Page 3
Refrigeration System . . . . .	Page 4
Evaporator for FM & FME type models . . . . .	Page 5
Evaporator for NM & NME type models . . . . .	Page 6
Gearmotor . . . . .	Page 7
Control Box . . . . .	Page 8
Wiring Diagrams . . . . .	Page 9

# RL Single System SERVICE PARTS

## Cabinet

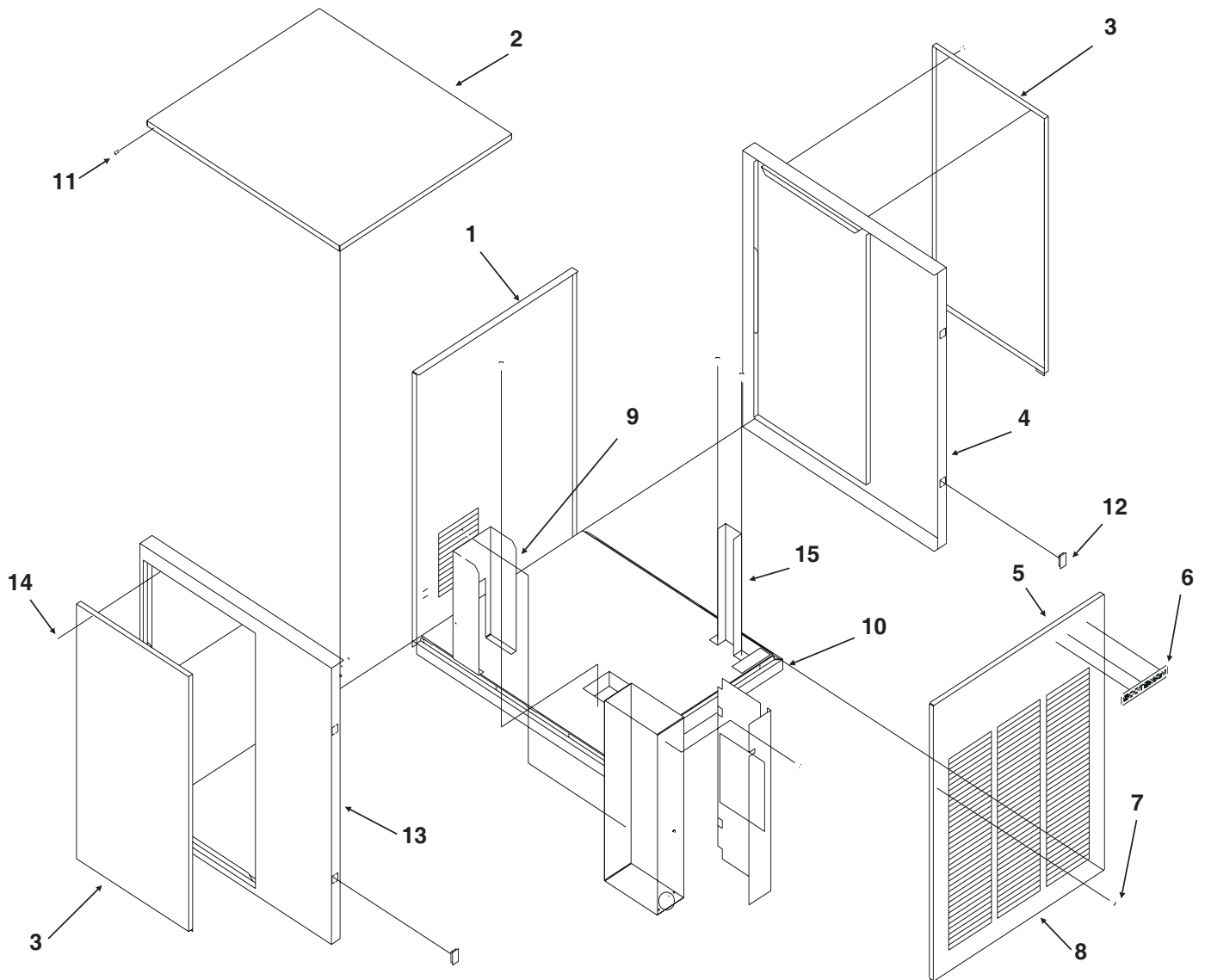

ITEM NUMBER	PART NUMBER	DESCRIPTION	ITEM NUMBER	PART NUMBER	DESCRIPTION
1	A35924-015	Back panel, gray	8	A33255-015	Front panel, gray
2	A33256-015	Top panel, gray		A33255-002	Front Panel, S.S.
	A33256-002	Top Panel, S.S.	9	A34039-001	Control Box Support
3	A34038-015	Service panel, gray	10	A35890-001	Base
	A34038-002	Service Panel, S.S.	11	03-1531-01	Screw
4	A33292-015	Right side panel, gray	12	02-0836-00	Catch
	A33292-002	Right Side Panel, S.S.	13	A32435-015	Left side panel, gray
5	03-0271-00	Speed Clip (order 3)		A32435-002	Left Side Panel, S.S.
6	15-0808-03	Emblem, grey	14	03-1404-12	Screw
7	03-1419-22	Screw	15.	A36078-001	Reservoir Bracket

# RL Single System SERVICE PARTS

## Water System

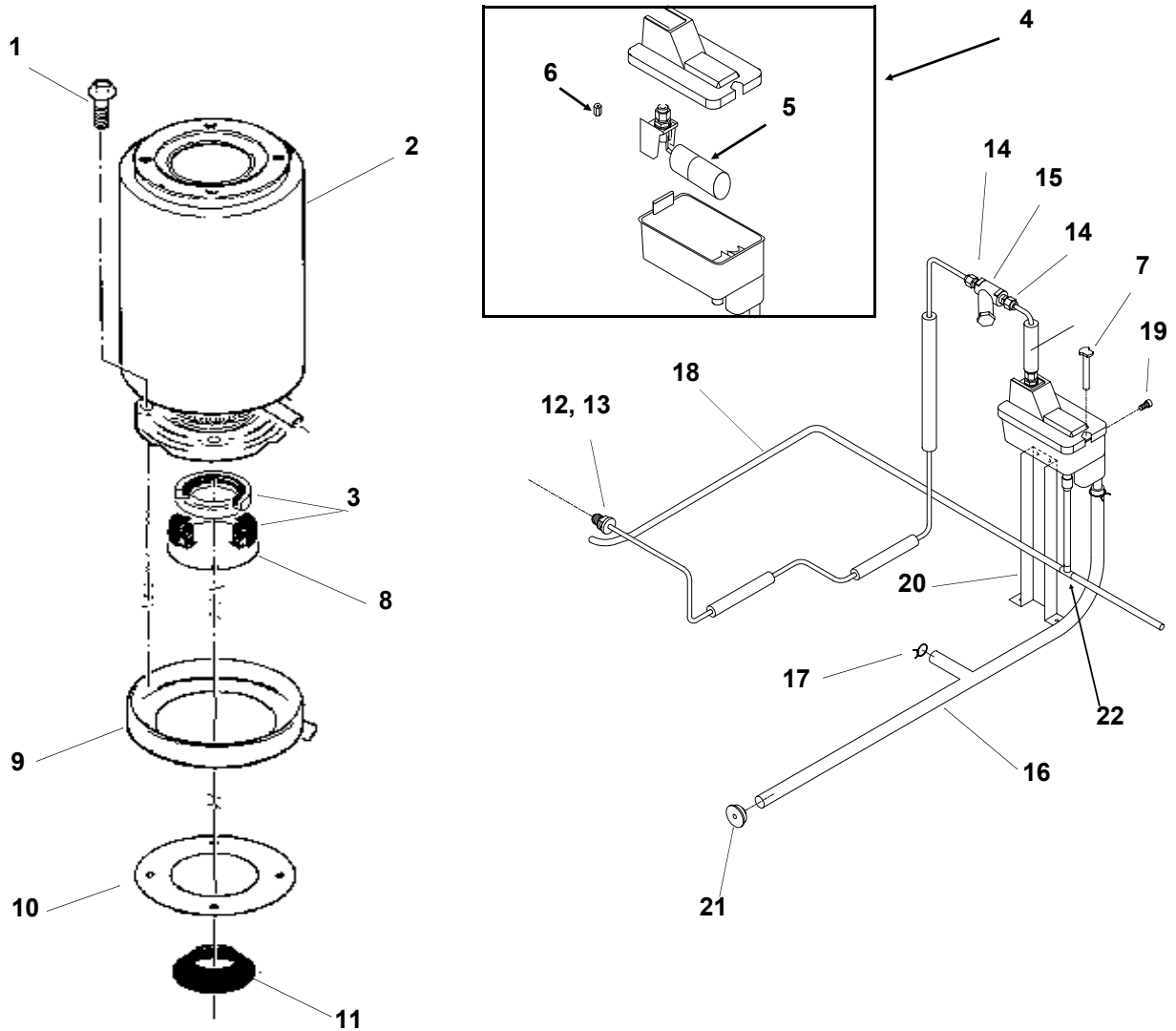

ITEM NUMBER	PART NUMBER	DESCRIPTION	ITEM NUMBER	PART NUMBER	DESCRIPTION
1	03-1405-46	Cap Screw	15	16-0162-00	Strainer - not used after 11/97
2	A32890-020	Evaporator	16	A36154-001	Evap. water inlet tube
3	02-0929-23	Water Seal	17	02-1338-00	Hose clamp
4	02-3266-20	Reservoir & valve	18	13-0079-03	Res. overflow hose 33"
5	02-3266-21	Float valve	19	03-1639-03	Screw
6	02-3266-03	Plunger/seat	20	A36078-002	Reservoir bracket
7	A33101-022	Water Level Sensor	21	13-0840-01	Rubber cap
8	A32777-001	Retaining Ring for Seal	22	16-0670-02	Tee
9	A32050-001	Drip Pan			
10	13-0704-00	Gasket			
11	13-0868-01	Water Shed			
12	A27318-001	Water Inlet Fitting for copper			
	16-0835-01	Inlet fitting			
	16-1039-01	Male connector for plastic			

# RL Single System SERVICE PARTS

## Refrigeration System

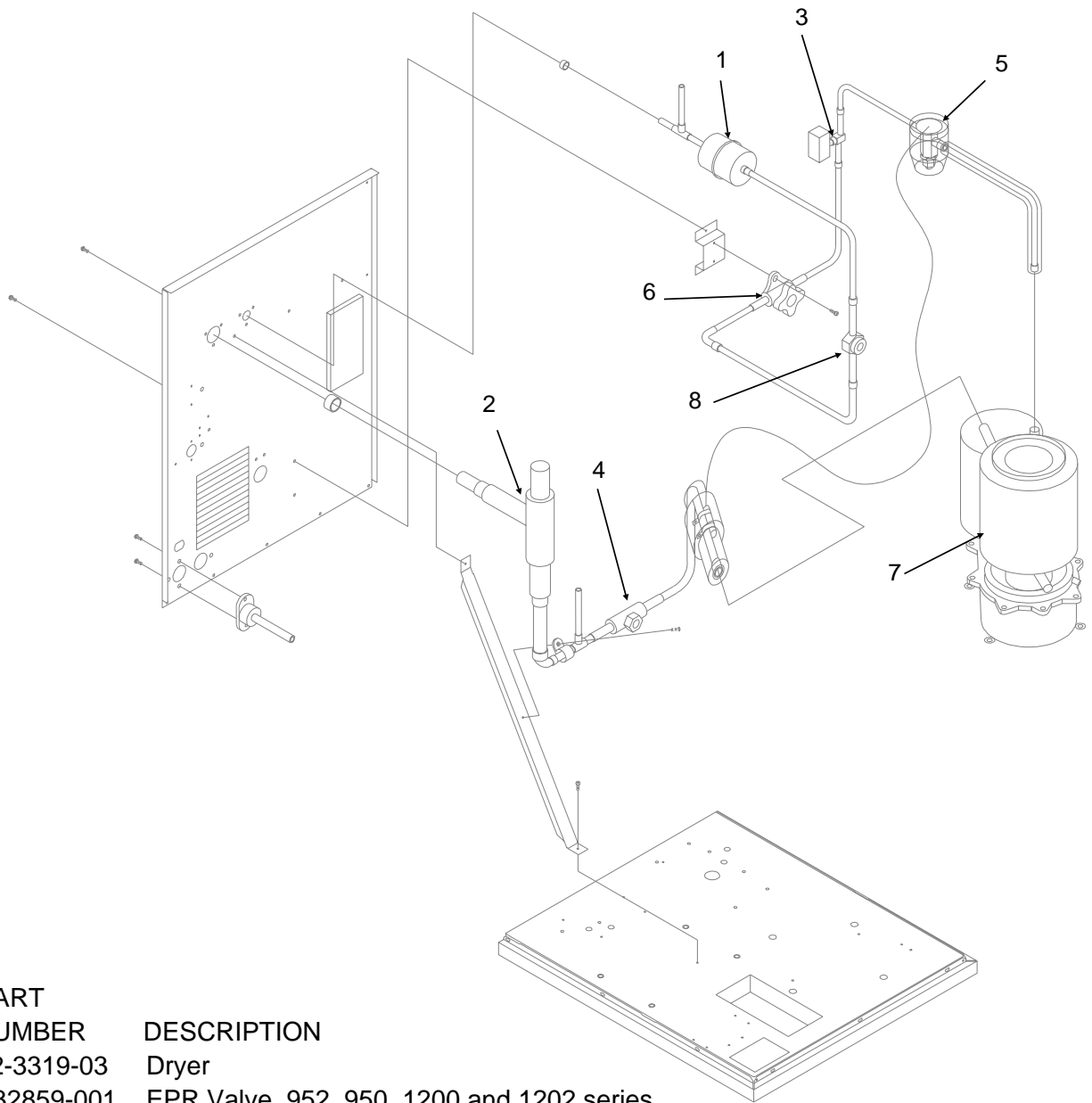

ITEM NUMBER	PART NUMBER	DESCRIPTION
1	02-3319-03	Dryer
2	A32859-001	EPR Valve, 952, 950, 1200 and 1202 series
	A32859-002	EPR Valve, 1250 and 1500 series
3	12-2135-22	Solenoid Valve
4	A32855-001	Ball Valve
5	11-0488-21	TXV for FME1200RL or NME950RL (R-404A)
	11-0482-21	TXV for FME1500RL or NME1250RL (R-404A)
	11-0477-20	TXV for FM1202RL or NM952RL (R-22)
6	11-0548-01	Shut Off Valve
7	A32890-020	Evaporator
8	16-0762-02	Sight Glass

# RL Single System SERVICE PARTS

## FM or FME Evaporator, Chute, Bin Controls

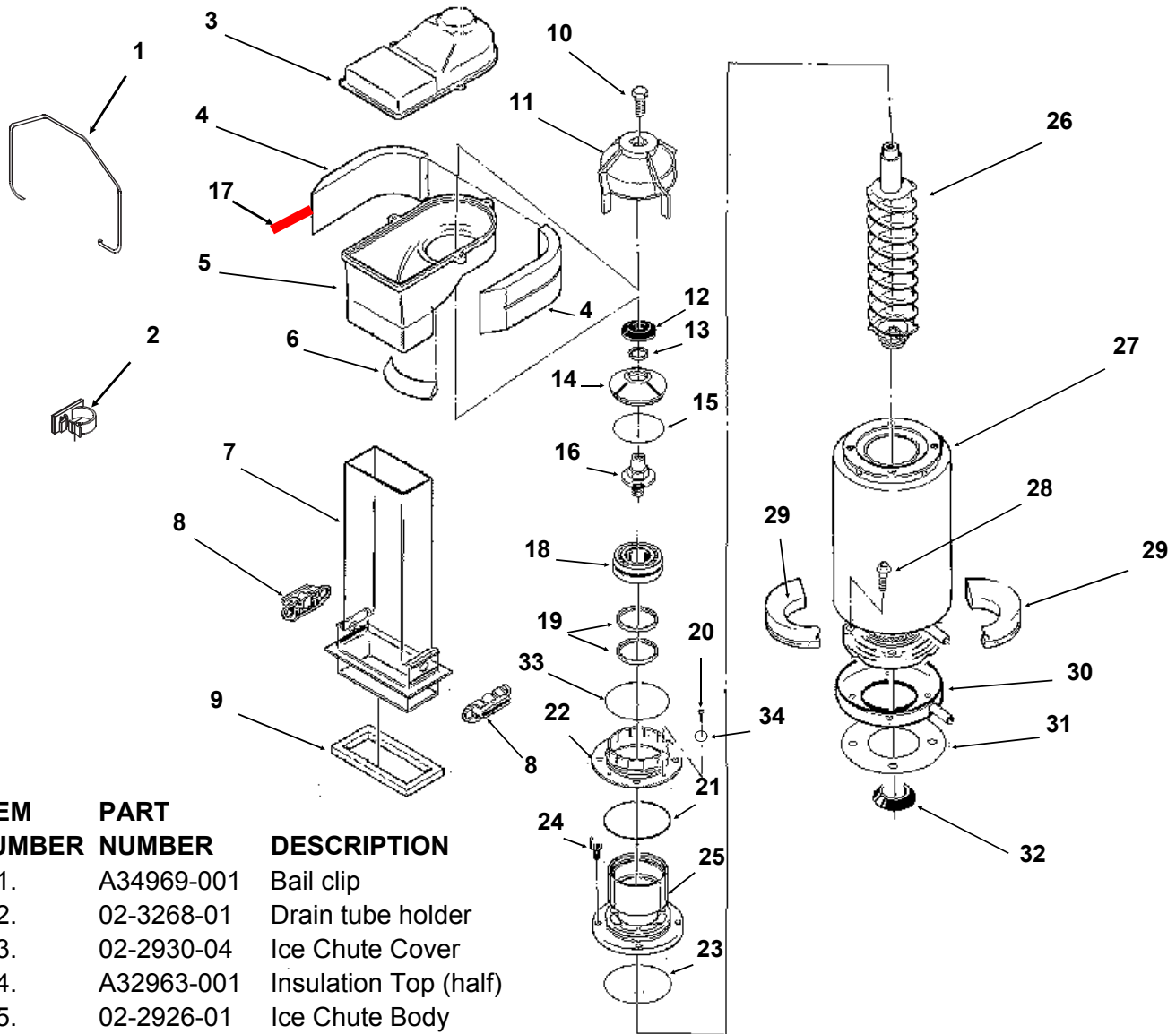

ITEM NUMBER	PART NUMBER	DESCRIPTION
1.	A34969-001	Bail clip
2.	02-3268-01	Drain tube holder
3.	02-2930-04	Ice Chute Cover
4.	A32963-001	Insulation Top (half)
5.	02-2926-01	Ice Chute Body
6.	A33102-001	Insulation Collar Inside
7.	02-2929-04	Ice Chute Lower
8.	A37708-021	Bin Controls Assy.
	(set of 2)	
9.	A32930-001	Chute Gasket
10.	03-1405-52	Hex Cap Screw
11.	02-3001-01	Ice Sweep
12.	13-0871-01	Water Shed
13.	02-2978-01	Lip Seal
14.	02-3128-20	Breaker Cover
15.	13-0617-54	O-Ring
16.	08-0660-01	Auger Stud, thrust Washer
17.	A35419-020	Strap kit
18.	A34559-020	Bearing
19.	02-2977-01	Lip Seal
20.	03-1405-27	Screw

21.	13-0617-52	O-Ring
22.	02-2916-01	Slotted Collar
23.	13-0617-45	O-Ring
24.	03-1544-08	Soc. Head Screw
25.	A34505-020	Breaker (Divider)
	(includes 18 & 19)	
26.	A38071-022	Auger
27.	A32890-020	Evaporator
28.	03-1420-03	Cap Screw
29.	A32962-001	Insulation Bot. (half)
30.	A32050-001	Drip Pan
31.	13-0704-00	Drip Pan Gasket
32.	13-0868-01	Water Shed
33.	13-0617-49	O-Ring
34.	03-1408-36	Washer

# RL Single System SERVICE PARTS

## NM or NME Evaporator

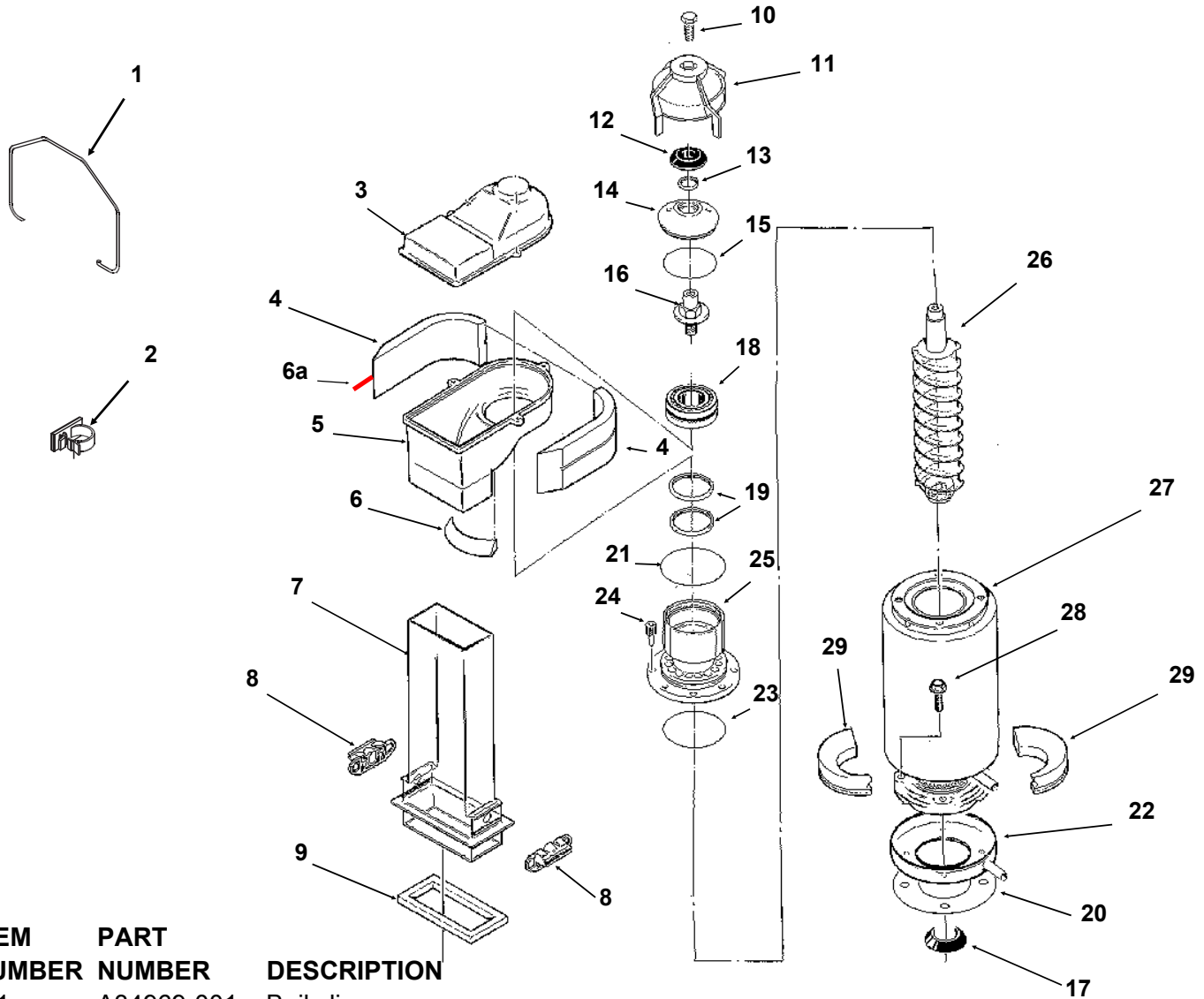

ITEM NUMBER	PART NUMBER	DESCRIPTION
1.	A34969-001	Bail clip
2.	02-3268-01	Drain tube holder
3.	02-2930-04	Ice Chute Cover
4.	A32963-001	Insulation Top (half)
5.	02-2926-01	Ice Chute Body
6.	A33102-001	Insulation Collar Inside
6a	A35419-020	Strap kit
7.	02-2929-04	Ice Chute Lower
8.	A37708-021	Bin Controls Assy. (set of 2)
9.	A32930-001	Chute Gasket
10.	03-1405-52	Hex Cap Screw
11.	02-3001-01	Ice Sweep
12.	13-0871-01	Water Shed
13.	02-2978-01	Lip Seal
14.	02-3128-01	Breaker Cover
15.	13-0617-52	O-Ring
16.	08-0660-01	Auger Stud & washer
17.	13-0868-01	Water Shed
18.	A34559-020	Bearing
19.	02-2977-01	Lip Seal
20.	13-0704-00	Drip Pan Gasket
21.	13-0617-54	O-Ring
22.	A32050-001	Drip Pan
23.	13-0617-45	O-Ring
24.	03-1544-08	Soc. Head Screw
25.	A32900-020	Breaker (includes 18 & 19)
26.	A38071-022	Auger
27.	A32890-020	Evaporator
28.	03-1420-03	Cap Screw
29.	A32962-001	Insulation Bot. (half)

# RL Single System SERVICE PARTS

## Gearmotor

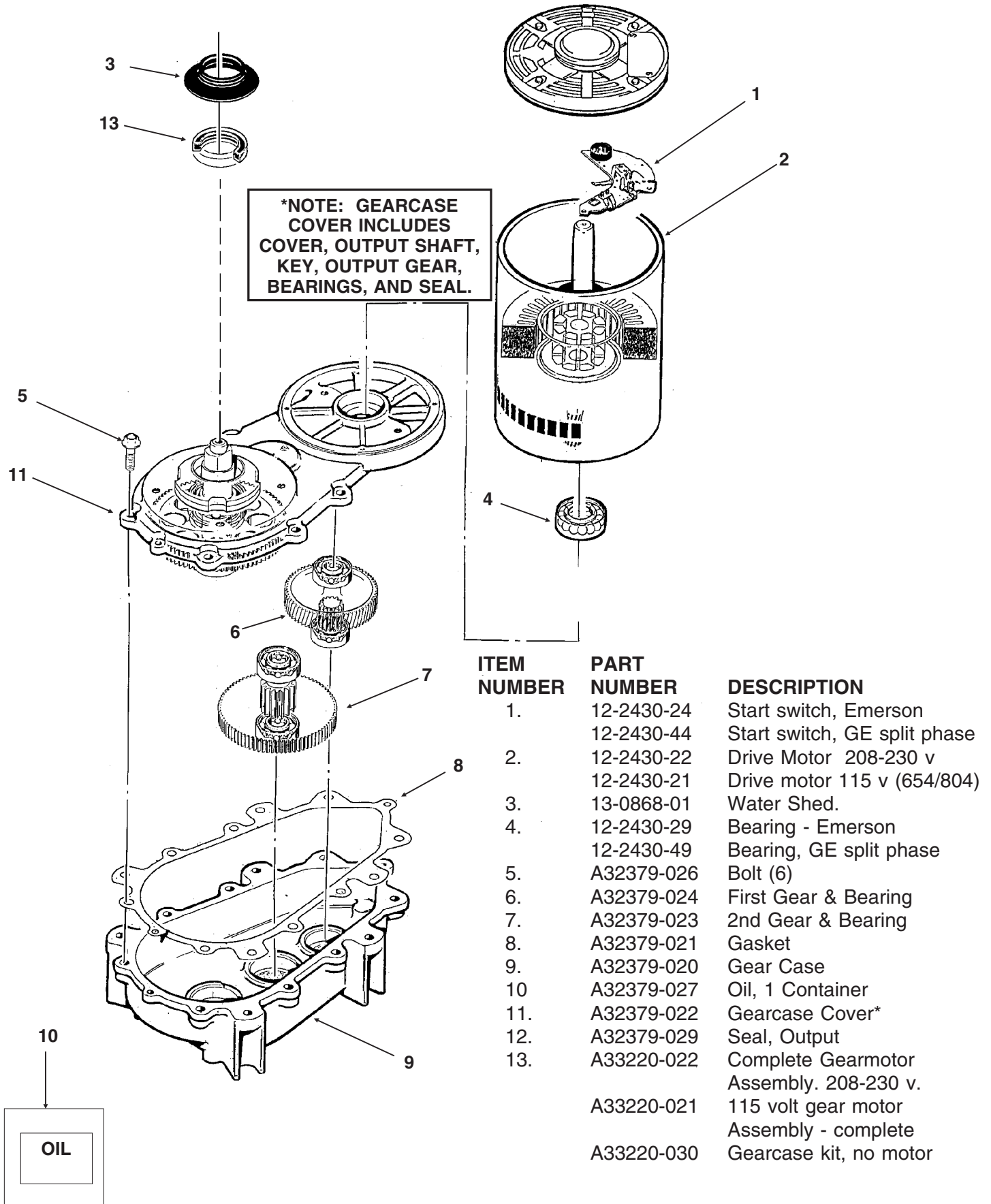

# RL Single System SERVICE PARTS

## Control Box

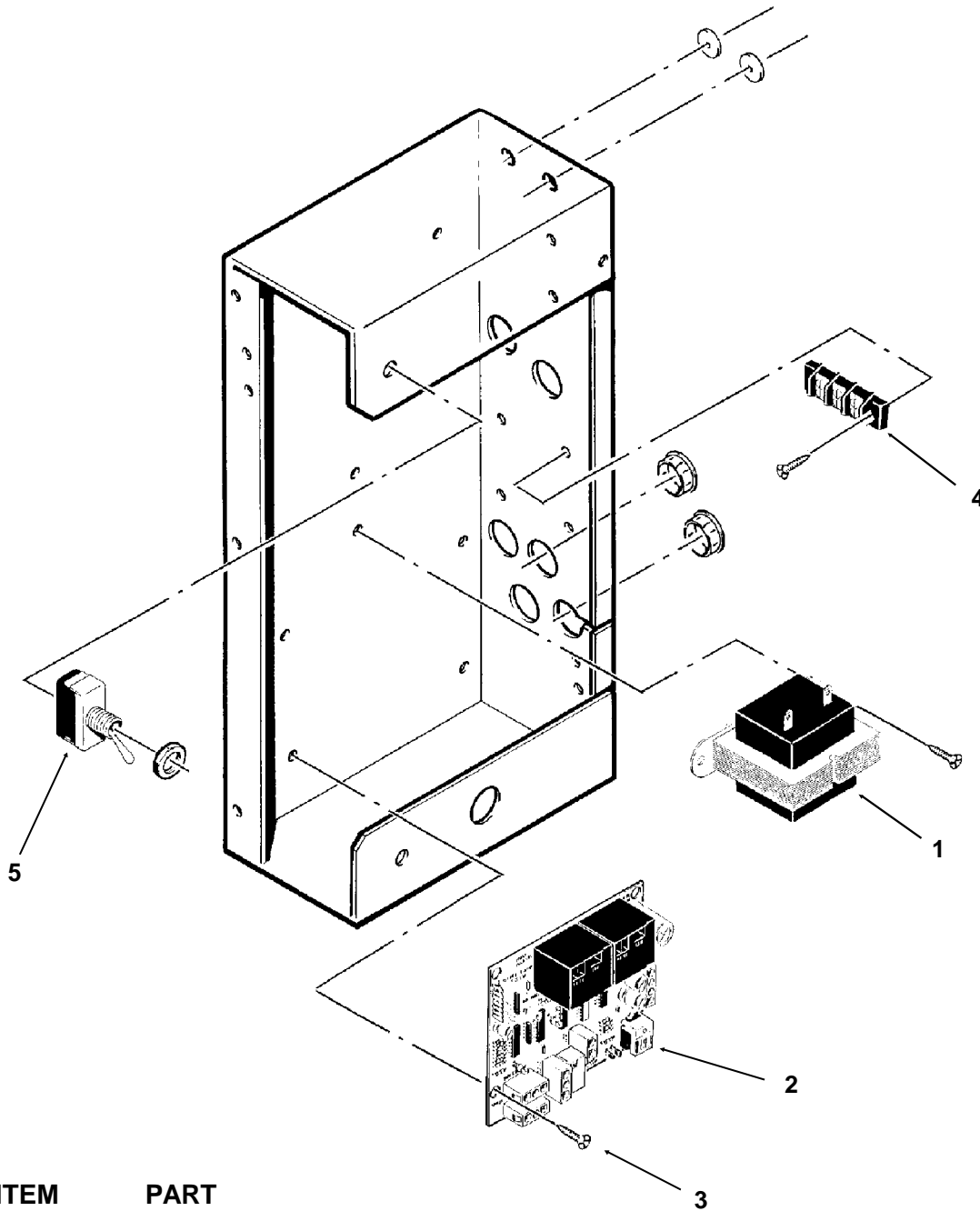

ITEM NUMBER	PART NUMBER	DESCRIPTION
1	12-2285-22	Transformer
2	A37750-021	Circuit Board
3	12-2350-01	Stand off
4	12-0813-04	Terminal Strip
5	12-0426-01	Master Switch

Not Illustrated:

6	12-2340-01	Wire harness to transformer
7	A34055-001	Control Box Cover

# RL Single System SERVICE PARTS Wiring Diagram

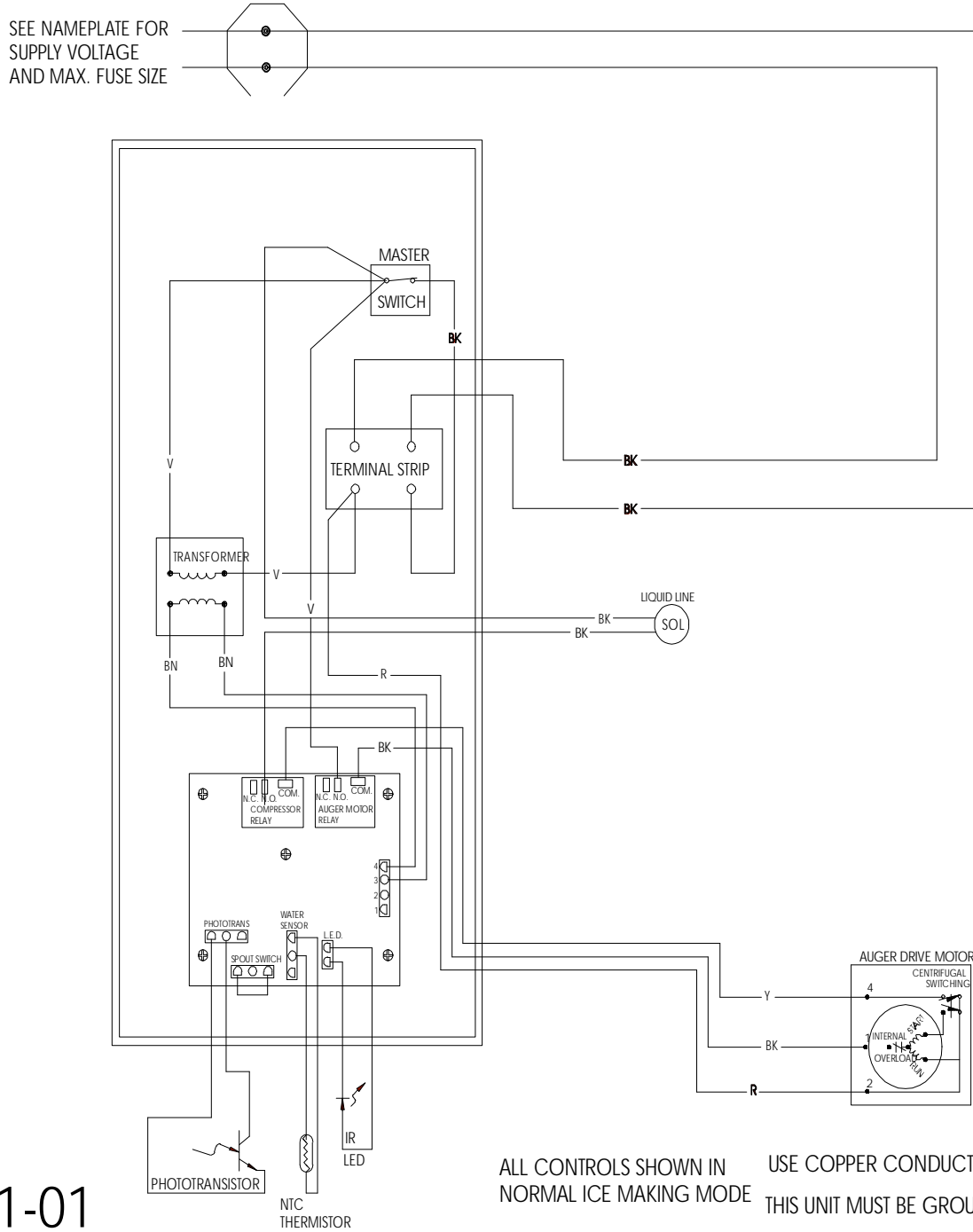

17-2491-01

# RL Single System SERVICE PARTS Schematic Diagram

