

SCN60

Service Parts

This is the illustrated parts list for the SCN60.
There are two models, one is a gravity drain and
the other includes a drain pump. Some units could
have had drain pumps field installed.

Table of Contents

Door Components	Page 2
Cabinet	Page 3
Storage Bin and Ice Chute	Page 4
Reservoir, Water Sensor and Misc	Page 5
Refrigeration	Page 6
Under Bin Parts	Page 7
Ice Making Section	Page 8
Control System	Page 9
Wiring Diagram	Page 10
Schematic Diagram	Page 11

Service Parts

Door Components

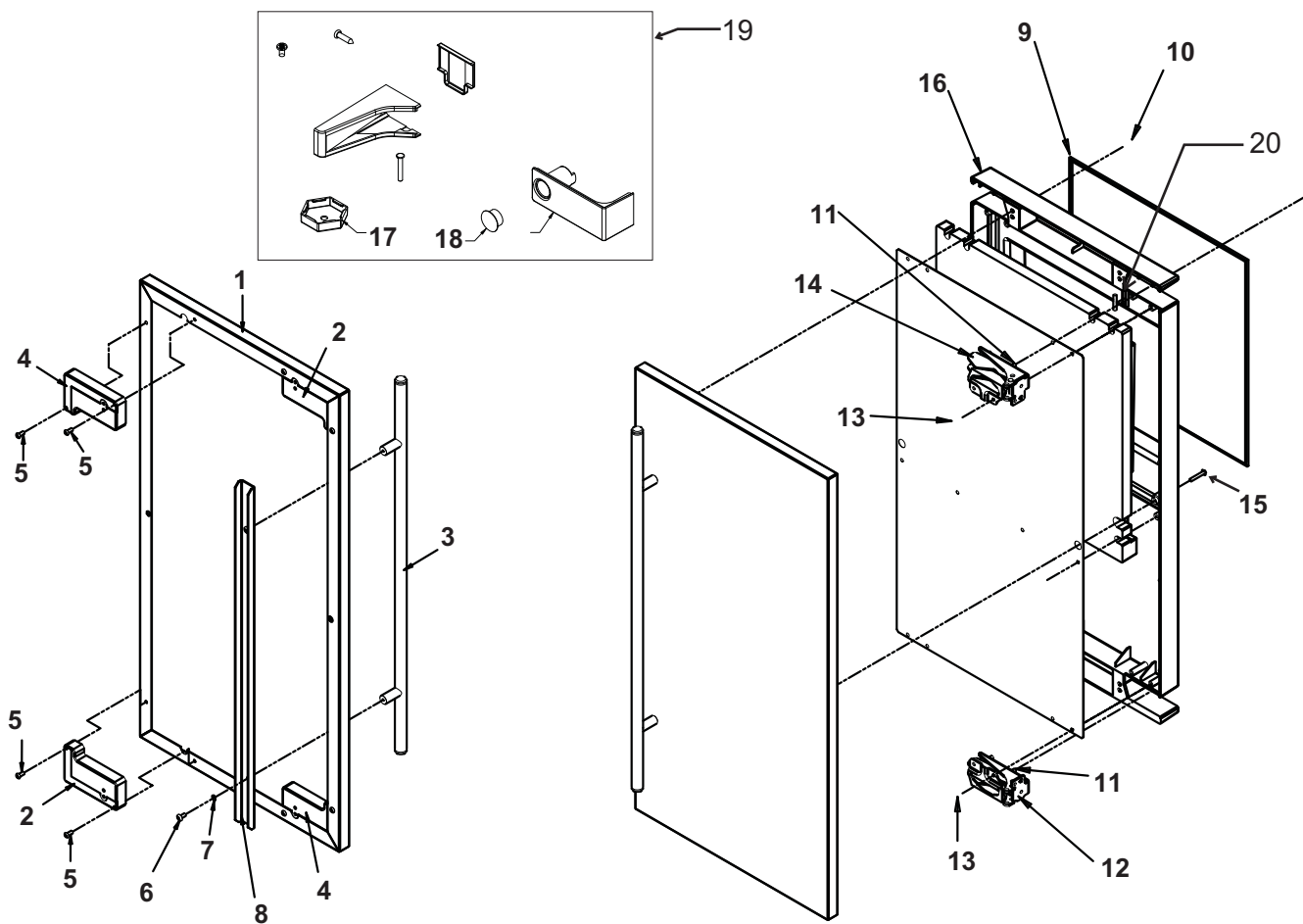

Item Number	Part Number	Description	Part Number	Description
1		Door panel kit. Kit includes items 1 thru 8.	16	A39513-001 Door assembly, does not include door panel or hinges
	KDFS	SS panel, SS handle	17	02-4415-20 Leg cap, pack of 4
2	02-4433-01	Corner block, RH	18	02-1875-07 Hole plug
3	02-4430-01	Handle, SS	19	02-4474-01 Hinge package
4	02-4433-02	Corner block, LH	20	11-0580-01 Magnet, door switch
5	03-1531-01	Screw		
6	03-3811-01	Screw		
7	03-1410-07	Lockwasher		
8	A39390-001	Support bracket		
9	13-0949-03	Door gasket		
10	03-1404-40	Screw		
11	03-3818-01	Screw - hinge to cabinet		
12	02-3866-04	Hinge - top right/bottom left		
13	03-1404-24	Screw - hinge to door		
14	02-3866-03	Hinge		
15	03-1403-67	Screw		

Service Parts

Cabinet

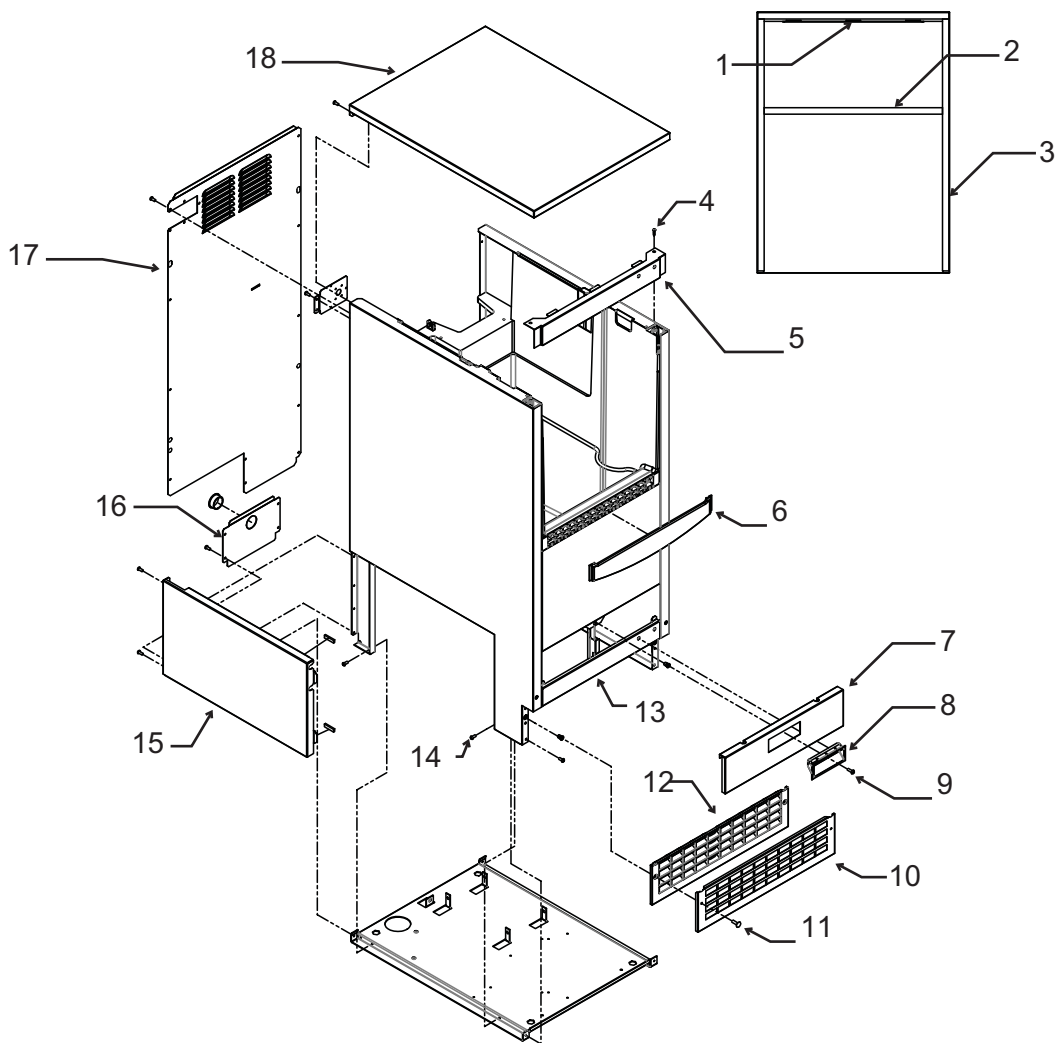

Item Number	Part Number	Description
1	13-0943-03	Gasket, top panel
2	13-0943-04	Gasket, top panel
3	13-0943-05	Gasket, top panel
4	03-3836-03	Screw
5	A39364-003	Top hinge bracket, hinge right
	A39364-006	Top hinge bracket, hinge left
6	02-4392-01	Inlay
7	A39381-003	Front service panel
8	02-4441-01	Handle
9	03-1403-86	Screw
10	A39469-001	Kick plate cover
11	03-3813-02	Screw
12	02-4390-01	Kick plate
13	A39385-003	Bottom hinge bracket, hinge right
	A39385-006	Bottom hinge bracket, hinge left
14	03-1531-01	Screw
15	A39615-001	Side service panel
16	A39683-001	Drain panel
17	A39682-001	Back panel
18	A39362-003	Top panel only
18a	02-4426-01	Insulation, top panel

Service Parts

Storage Bin and Ice Chute

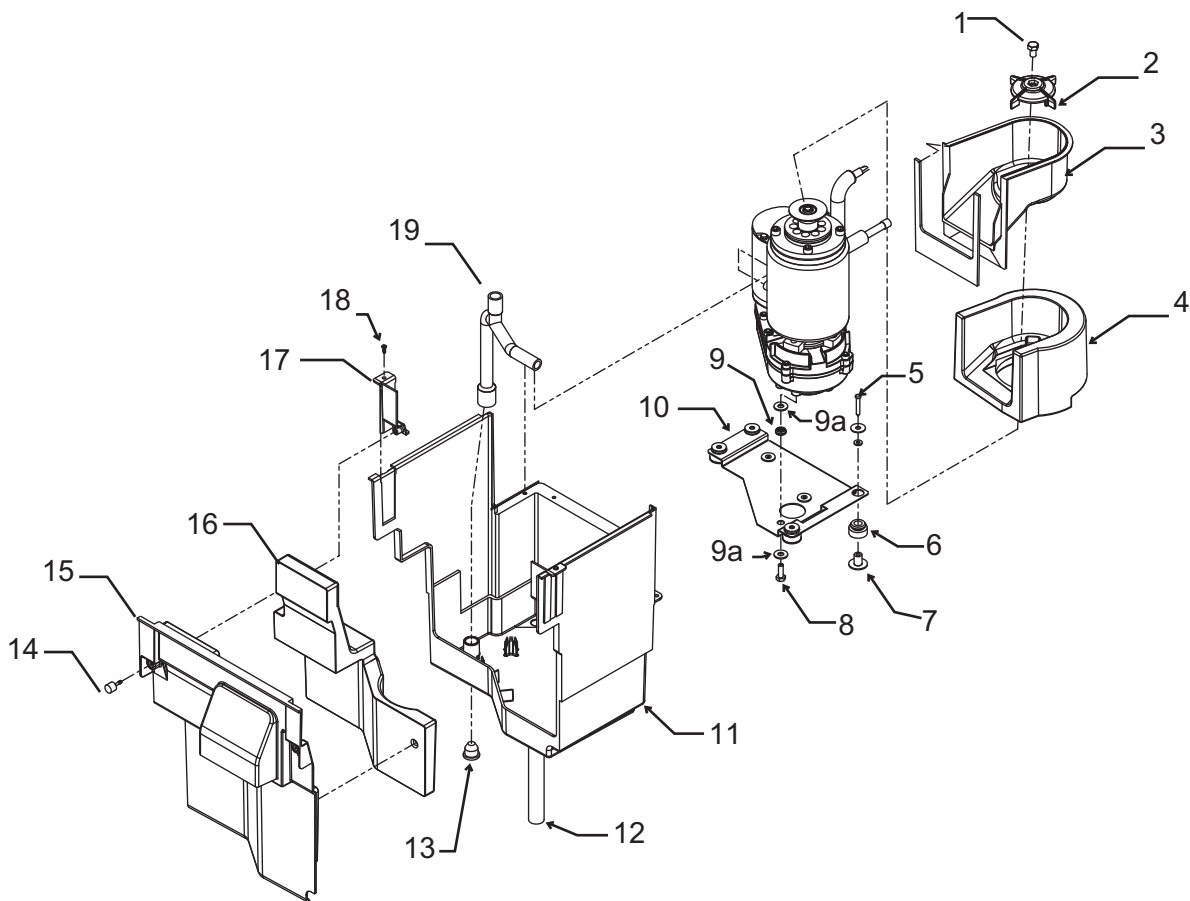

Item Number	Part Number	Description
1	03-1405-16	Screw, 5/16-18
2	02-4628-01	Ice sweep
3	02-4537-21	Chute
4		Chute insulation, part of item 3
5	03-1404-41	Screw
6	03-3935-01	Grommet
7	03-3936-01	Flanged bushing
8	03-1405-07	Cap screw
9	03-3937-01	Vibration grommet
9a	03-1407-06	Washer
10	A39681-001	Mounting plate only
11	02-4582-01	Shelf, gear and evap asy
12	A39782-001	Drain
13	13-0840-01	Drain plug
14	03-3892-01	Thumb screw
15	02-4585-21	Cover
16		Cover insulation, part of item 15
17	02-4375-01	Support bracket, left
	02-4375-02	Support bracket, right
18	03-3836-03	Screw
19	02-4572-01	Tube, reservoir to evap

Service Parts

Reservoir, Water Sensor and Misc

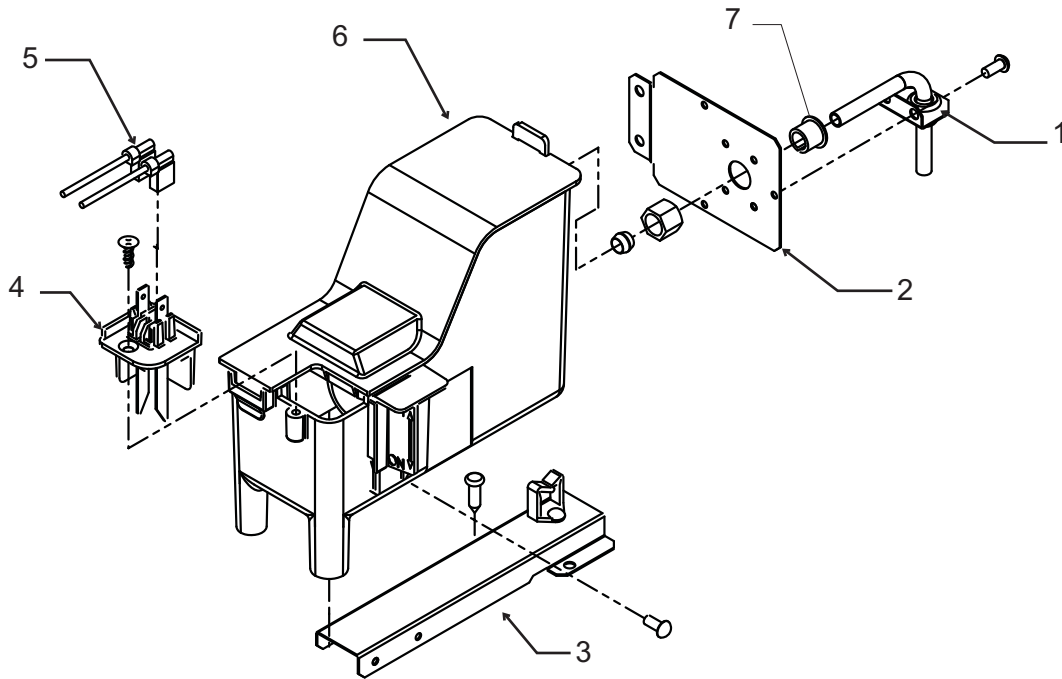

Item Number	Part Number	Description
1	A39826-001	Brace
2	A39693-001	Bracket
3	A39775-001	Reservoir mounting bracket
4	A39790-001	Water level sensor
5	12-3039-01	Water sensor harness
6	A39789-001	Reservoir w/valve and cover
6a	02-2217-02	Float and valve only

Misc:

1m	19-0664-01	Pre-Mixed Squirt Bottle of Clear 1 scale remover
2m	19-0664-12	12 pack of item 1m
3m	19-0653-12	Case of undiluted Clear 1 scale remover

Service Parts

Refrigeration

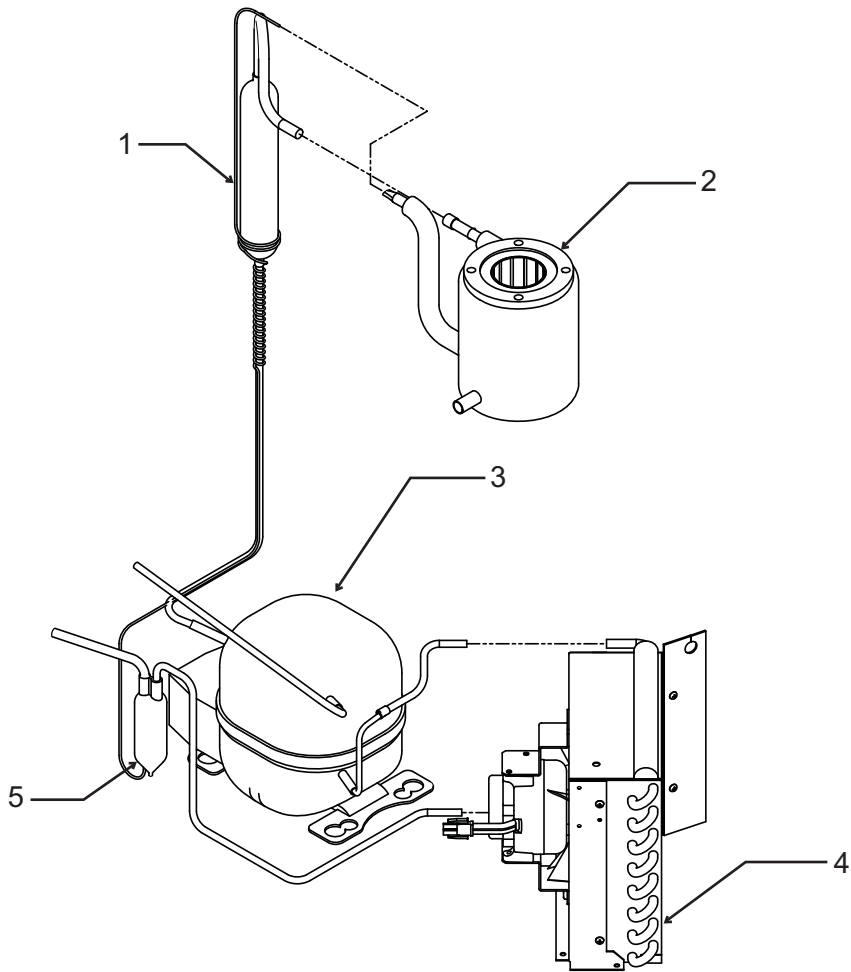

Item Number	Part Number	Description
1	A39396-001	Suction line w/cap tube
2	02-4558-01	Evaporator
3	18-8776-21	Compressor
Compressor includes overload, relay and drier		
3a	18-8776-52	Overload
3b	18-8776-51	Relay
4	18-8940-01	Condenser
5	02-3490-01	Dryer

Service Parts

Under Bin Parts

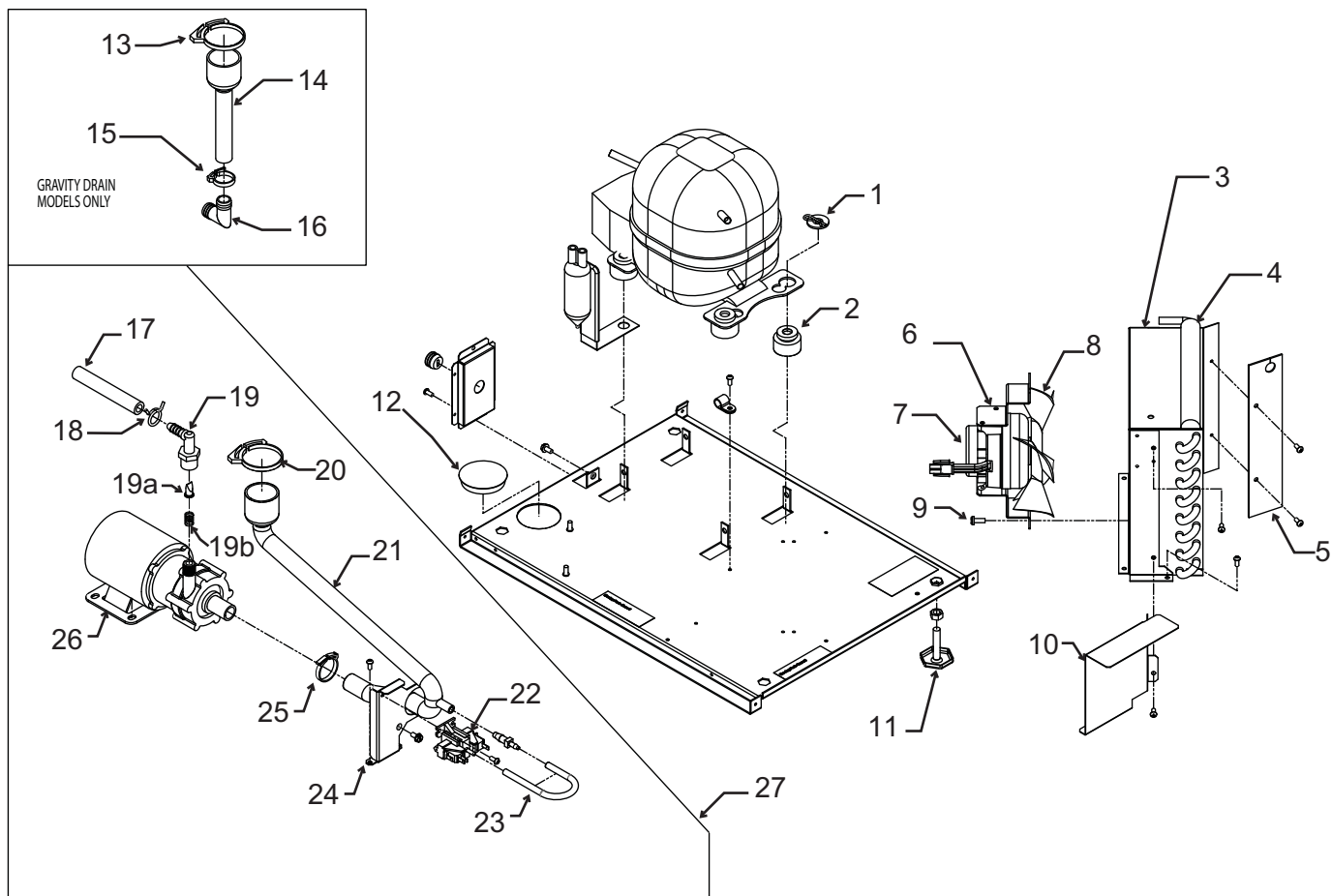

Item Number	Part Number	Description	Item Number	Part Number	Description
1	03-3821-01	Clip	18	02-0534-02	Hose clamp
1a	03-1407-08	Washer	19	02-3522-01	Elbow
2	18-4700-28	Grommet	20	02-2814-13	Hose clamp
3	A39460-001	Shroud	21	02-4413-01	Drain tube
4	13-0909-01	Gasket - order 1 & cut to fit	22	11-0504-01	Pressure switch
5	02-4450-01	Air baffle	23	05-0591-01	Switch hose
6	A39556-001	Fan motor bracket	24	A39370-001	Switch bracket
7	12-3024-01	Fan motor	25	02-2814-13	Hose clamp
8	02-4197-01	Fan blade	26	12-2503-21	Pump & motor only
9	03-3818-01	Screw	27	A39462-021	Pump kit
10	A39825-001	Pump model rain shield			
11	03-1608-01	Leg leveler			
12	02-1875-18	Hole plug			
13	02-2814-13	Hose clamp			
14	02-4412-01	Drain hose			
15	02-2814-08	Hose clamp			
16	16-0671-01	Elbow			
17	A37334-001	Discharge hose			

Service Parts
Ice Making Section

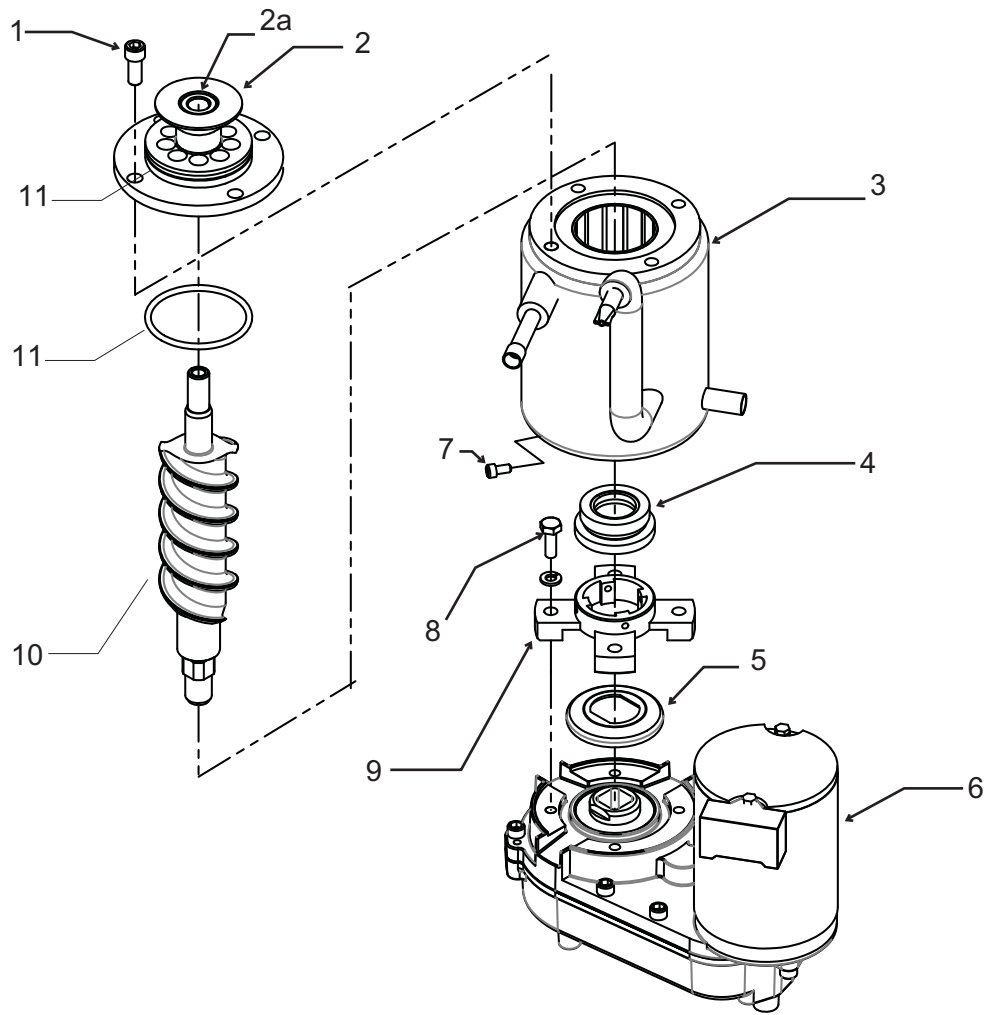

Item Number	Part Number	Description
1	03-1544-08	Cap screw
2	A39531-001	Breaker w/bearing
2a	02-4619-01	Bearing only
3	02-4558-01	Evaporator
4	02-4599-21	Water seal
5	02-4662-01	Water shed
6	02-4580-21	Gear reducer complete
7	03-1544-04	Cap screw
8	03-1405-54	Cap screw
9	02-4625-01	Adapter
10	02-4591-21	Auger
11	13-0617-58	O-ring

* Must connect wires correctly. See label on motor.

Service Parts

Control System

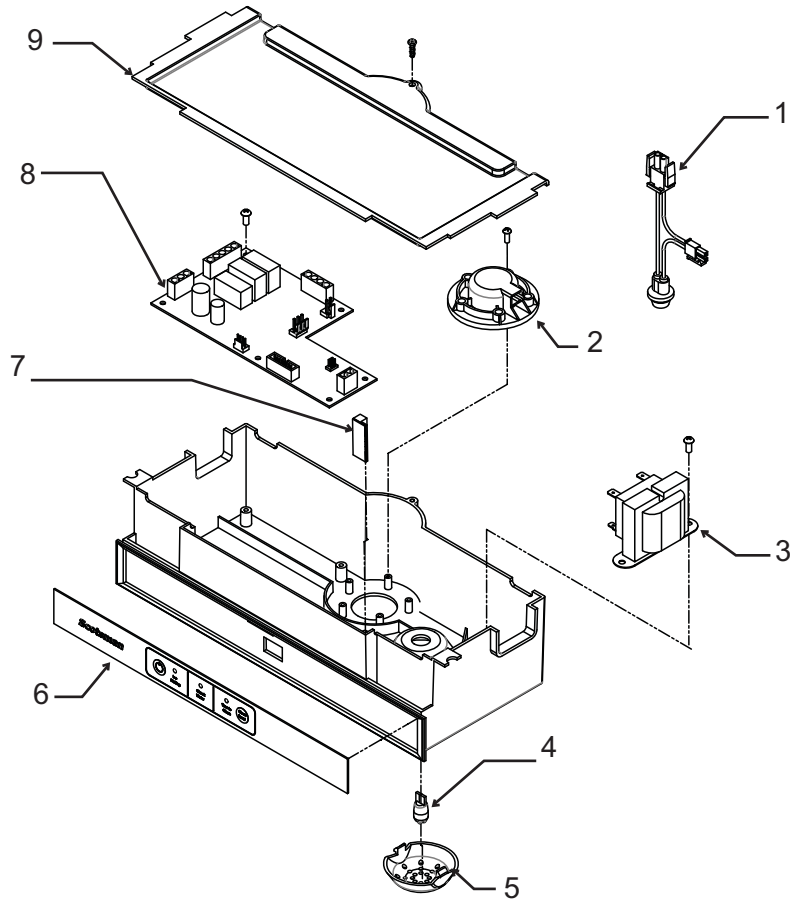

Item Number	Part Number	Description
1	12-2980-02	Harness, bin light
2	11-0579-01	Ice level sensor
3	12-2924-01	Transformer
4	12-2980-01	Bulb
5	02-4380-01	Light cover
6	11-0574-01	Control panel
7	12-2980-03	Bin light switch
8	11-0589-21	Controller
9	02-4386-01	Cover

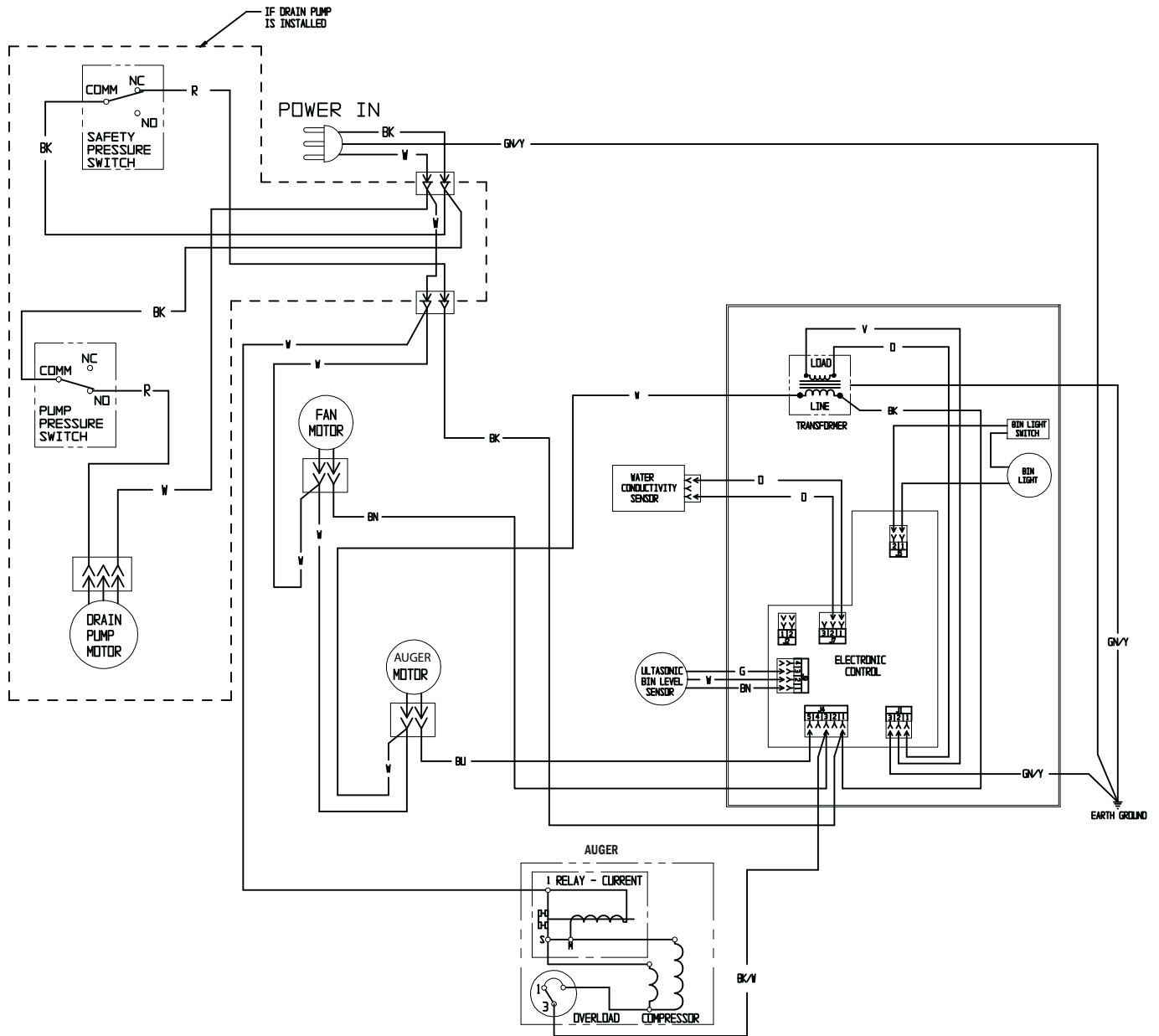

Service Parts

Schematic Diagram

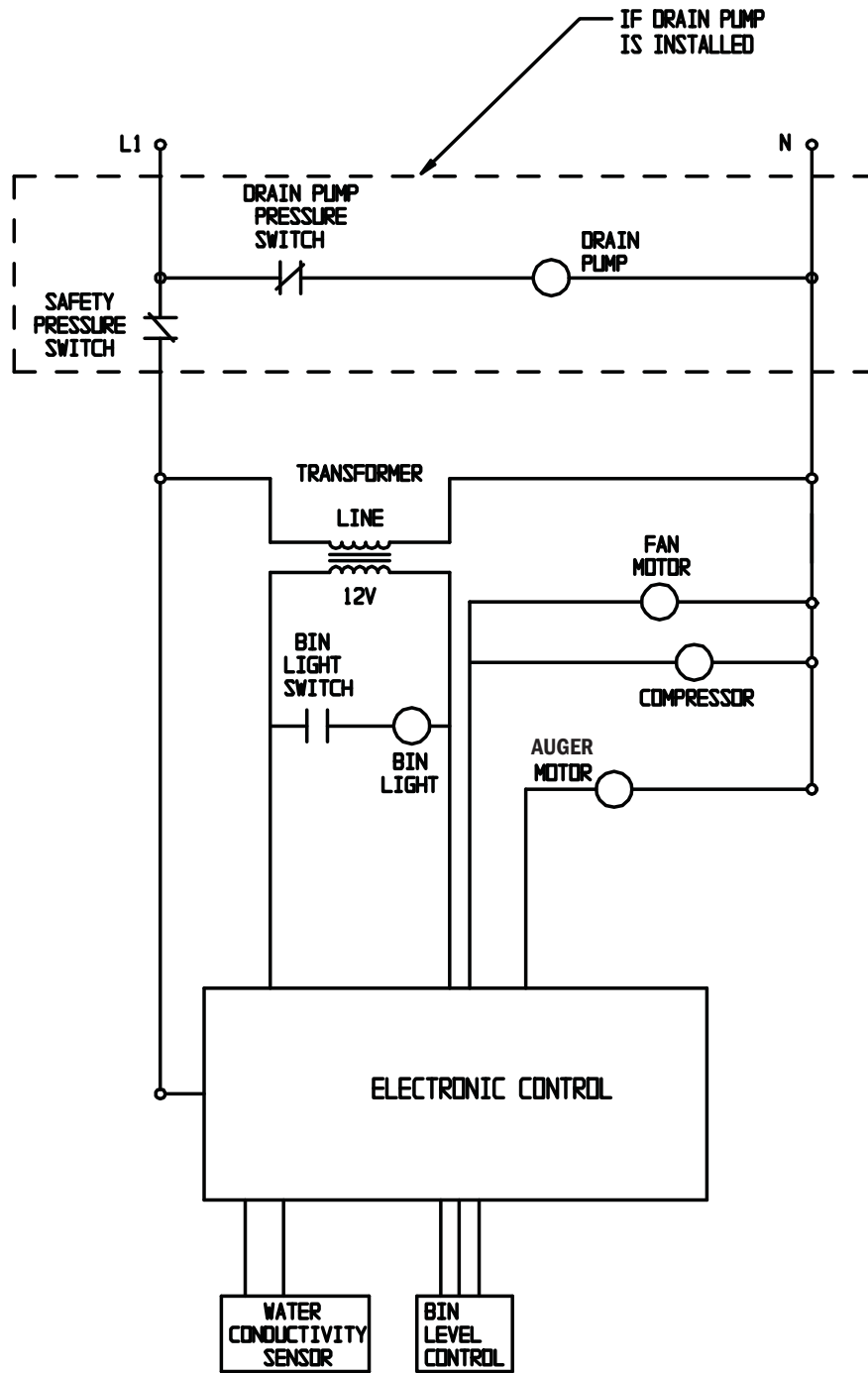

SWITCHES ON THIS UNIT
SHOWN IN FREEZE CYCLE
WITH DRAIN PUMP IN OPERATION
AND BIN DOOR CLOSED