



N0622 - 600lb Nugget Ice Machine

Prodigy Plus® Nugget Ice Machine

Superior performance with every cup.

Now the soft, chewable nugget ice that customers love is available with more innovative technology than ever before. With next-generation diagnostics like AutoAlert™ indicator lights on the new Scotsman Prodigy Plus® nugget ice machines, operators can help ensure superior performance while enjoying maximum efficiency — every day. And with features like advanced ice level control, a small operational footprint and easy-access service from the front panel, Prodigy Plus® nugget ice machines are the smart choice for today's busy food-service environments.



The Prodigy Plus® difference.

- The Original Chewable Ice®
- AutoAlert™ indicator lights for better visibility
- Operational footprint among the industry's smallest
- Industry-exclusive QR code instantly connects users to service information and warranty history
- Front-located air filter for more efficient operation
- Self-aligning front panel for easy access to key components
- Smart-Board™ advanced feature module available for additional diagnostic capabilities
- Optional Vari-Smart™ ice level control allows operators to customize ice levels
- Antimicrobial protection guards internal surfaces between cleanings
- A full range of water- and energy-saving features

N0622 - 600lb Nugget Ice Machine



24 Hour Volume Production

Air Cooled		Remote Cooled		Water Cooled	
70°F/21°C	Air	90°F/32°C	70°F/21°C	90°F/32°C	70°F/21°C
50°F/10°C	Water	70°F/21°C	50°F/10°C	70°F/21°C	50°F/10°C
643/292		547/249	660/299	579/263	715/325
lb/kg		lb/kg	lb/kg	lb/kg	lb/kg



Modular Bin & Dispenser Options



B530S



ID200

Model Number*	Dimensions W" x D" x H"	AHRI Certified Bin Capacity lb/kg	Finish	Ship Weight lb/kg
B322S	22 x 34 x 44**	290/132	Metallic	140/64
B530P	30 x 34 x 44**	420/191	Poly	150/68
B530S	30 x 34 x 44**	420/191	Metallic	110/50
ID150	22 x 30 x 35.625	-	Stainless Steel	150/68
ID200	30 x 30 x 35.625	-	Stainless Steel	195/89
ID250	30 x 30 x 39.625	-	Stainless Steel	200/91

*Contact Scotsman for bin top requirements. **Add 6" Height for bin legs.



Nugget Ice



The Original Chewable Ice™! Soft ice ideal for fountain beverages and blended fruit drinks.



Certification



Warranty

- 3 years parts and labor on all components.
- 5 years parts on the compressor.
- Warranty valid in North, South & Central America for commercial installations.
- Contact factory for warranty in other regions.



N0622 - 600lb Nugget Ice Machine

Prodigy Plus® Nugget Ice Machine

N0622 - 600lb Nugget Ice Machine

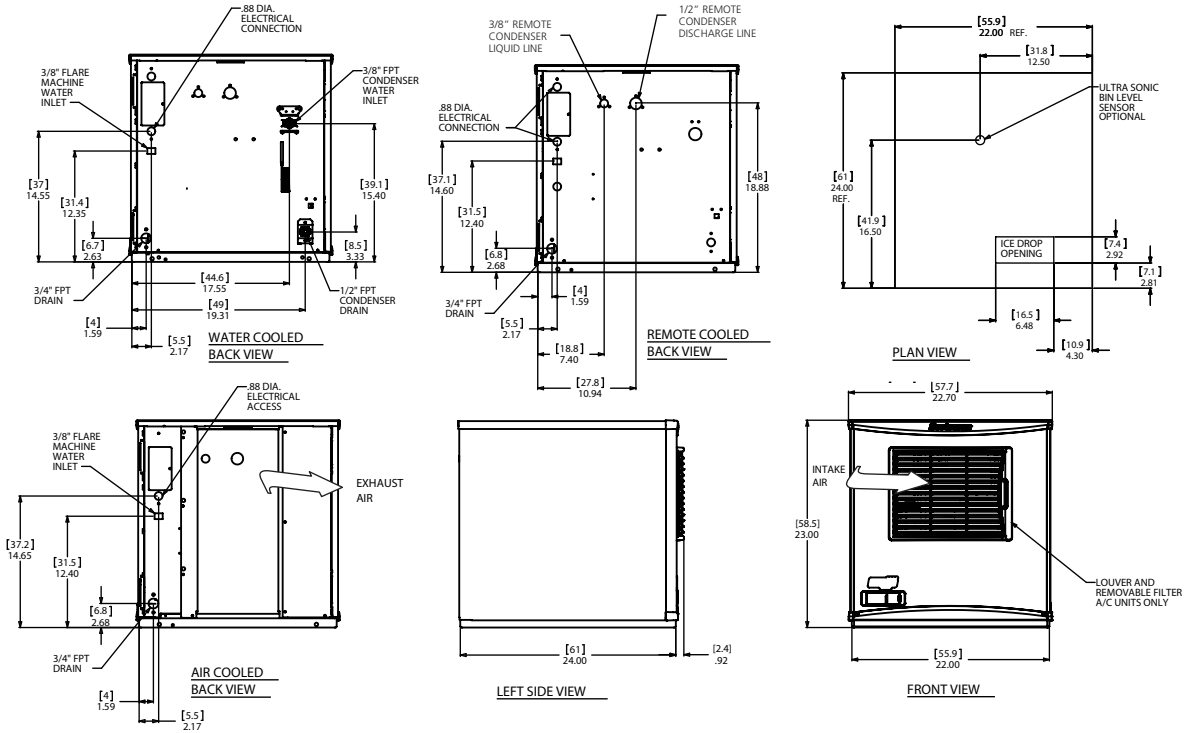

Specifications

Model Number	Condenser Unit	Basic Electrical Volts/Hz/Phase	Max. Fuse Size or HACR Circuit Breaker (amps)	Circuit Wires	Min. Circuit Ampacity	Energy Consumption kWh/100 lb (45.4 kg) 90°F(32°C)/70°F(21°C)	Water Usage Gallons/100 lb (liters/45.4 kg)	
							Potable 90°F(32°C)/70°F(21°C)	Condenser 90°F(32°C)/70°F(21°C)
N0622A-1	Air	115/60/1	25	2	18.3	4.65	12.0/45.5	-
N0622R-1	Remote	115/60/1	25	2	19.4	4.95	12.0/45.5	-
N0622W-1	Water	115/60/1	25	2	16.7	3.80	12.0/45.5	102/386.7
N0622A-32	Air	208-230/60/1	15	2	9.8	4.65	12.0/45.5	-



All Models

Dimensions (W x D x H):

Unit: 22.9" x 24" x 23"
(58.2 x 61.0 x 58.4 cm)

Shipping Carton: 25.5" x 27.5" x 28.5"
(64.8 x 69.9 x 72.4 cm)

Shipping Weight: 172 lb / 78 kg BTUs per hour: 7,100

Refrigerant: R-404A



Accessories

Model Number	Description
KVS	Vari-Smart™ Ice Level Control - Program ice bin levels to match ice needs.
KSBU	Smart-Board™ Advanced Control - Use additional operational data for fast diagnosis.
KSBU-N	Smart-Board™ Advanced Control with Network - Network capable.
ERC 111-1	Remote condenser for N0622R, 115V/60/1 -
RTE10	Line set, pre-charged, R404A, 10ft.
RTE25	Line set, pre-charged, R404A, 25ft.
RTE40	Line set, pre-charged, R404A, 40ft.
RTE75	Line set, pre-charged, R404A, 75ft.
KPAS	Prodigy Advanced Sustainability Kit - Includes KVS and KSBU - N

Scotsman recommends all ice machines have water filtration. See Scotsman water filter specification sheet for details.



Operating Requirements

	Minimum	Maximum
Air Temperatures	50°F (10°C)	100°F (38°C)
Water Temperatures	40°F (4.4°C)	100°F (38°C)
Remote Cond. Temps	-20°F (-29°C)	120°F (49°C)
Water Pressures	20 PSIG (1.4 bar)	80 PSIG (5.5 bar)
Electrical Voltage	-5%	+10%

Specifications and design are subject to change without notice.