

Instructions

Stacking Kit, KSCME6-LG-B Installation

The installation of the stacking kit begins after the bottom unit has been placed on the ice storage bin and secured with hardware from that machine. Stacking requires heavy duty leg kits and casters are NOT recommended.

Note: Instructions are for both 5 and 6 plate machines, photos are of either type.

Kit Contents: 27 feet of foam gasket, 1 wire harness, 2 strain reliefs, 6 screws, 2 shields (left and right), 1 bracket, 1 support bracket, 1 tube of food grade sealant.

Bottom Machine:

1. Remove front panel, left side panel, and top panel.
 2. Remove & discard top cover from over the freezing compartment.
 3. Install gasket materials to freezing compartment:
 - Cut about 22" of gasket material from the roll in the kit. Apply it to the back side top edge of the freezing compartment.
 - Cut two lengths of gasket material to fit the right side top edge of the freezing compartment and apply them.
 4. Place a bead of food grade sealant to the top of the back wall's gasket.
 5. Place the shield bracket (has a large hole in the center) from the kit over the center of the freezing compartment.
- Insert the tabs of the bracket into slots on the back of the unit.

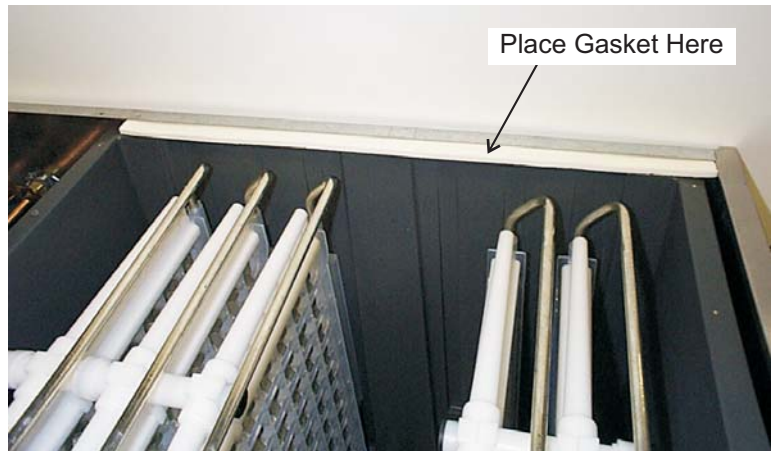

Install Gasket

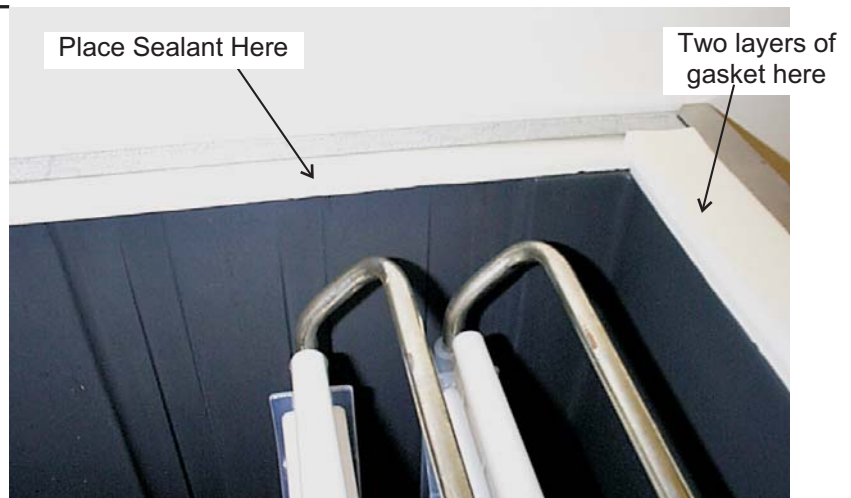

Apply Gasket to Right Edge

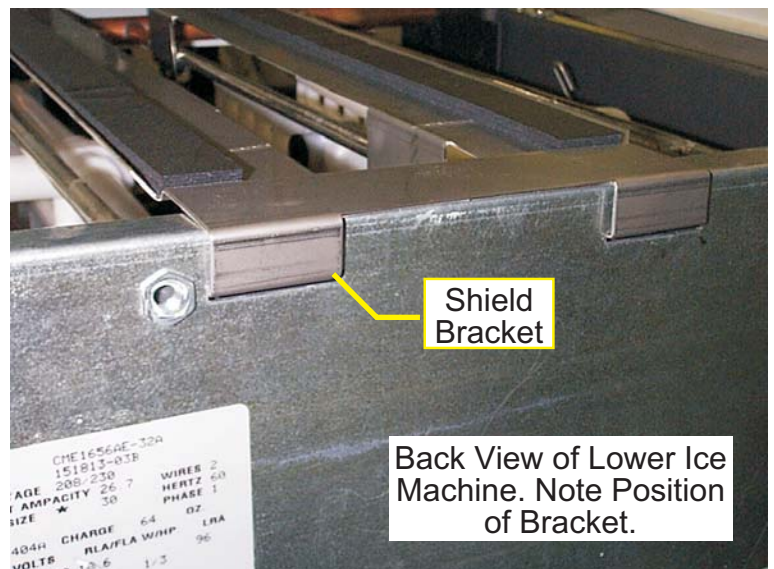

Back View of Lower Ice Machine. Note Position of Bracket.

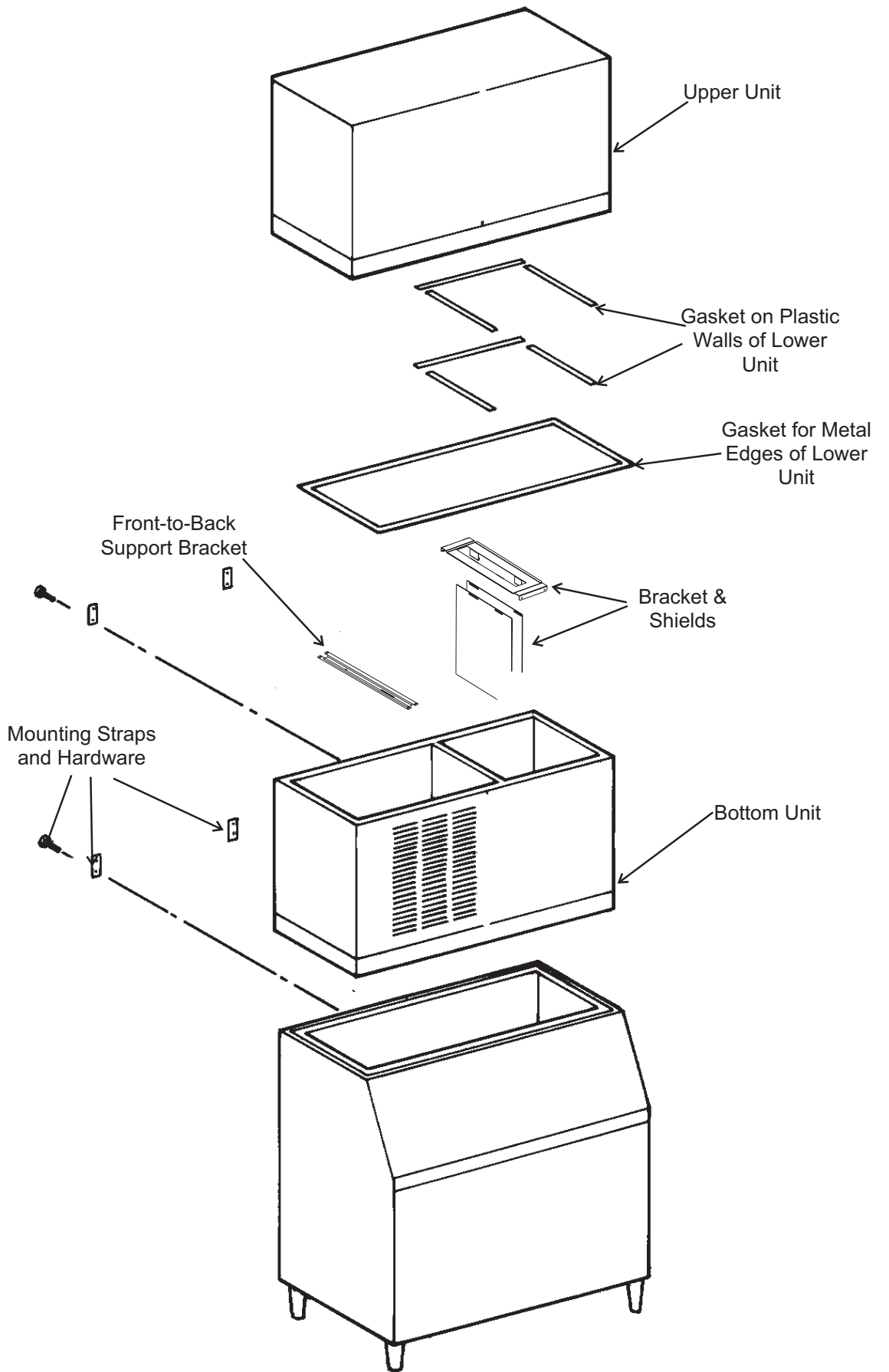

6. Secure bracket at the front with screws from the kit.

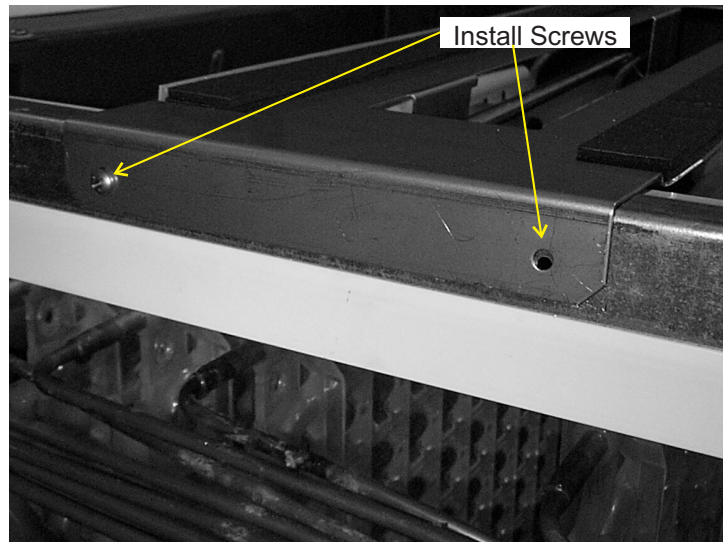

Install Screws

Attach Bracket to Bottom Ice Machine

7. Hang the plastic shields from the bracket installed in the prior step. Use the slots in the shields to hang them from the stainless steel hooks.

Note: The notch in the bottom of the shield goes to the front.

=====

Note: The tabs on the shields must fit inside the ice outlet port.

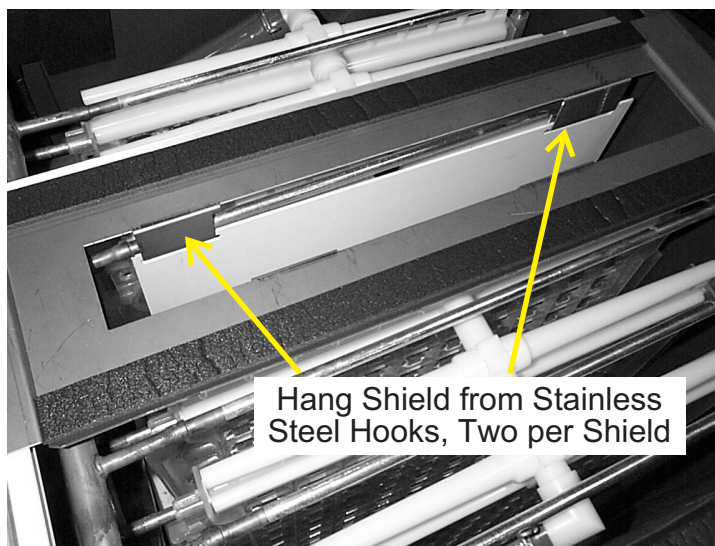

Hang Shield from Stainless Steel Hooks, Two per Shield

8. Check the position of the shields. They must move freely and be vertical.

Note: The suction line may need to be moved slightly so the tubing clears the bracket & shields.

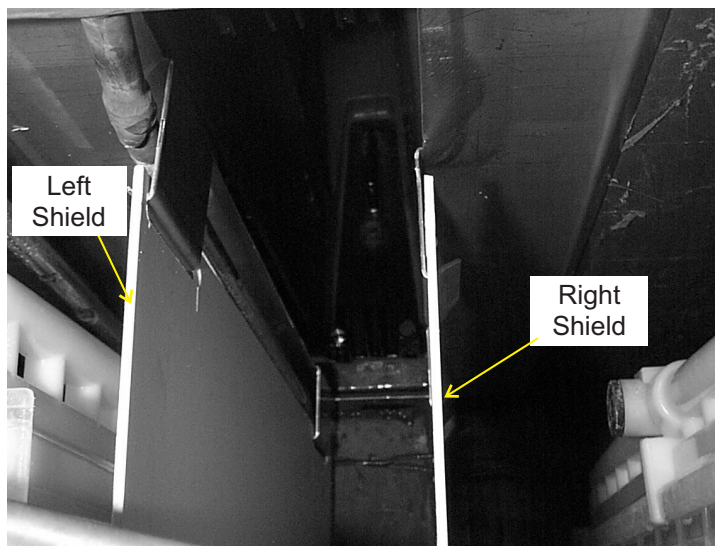

Left Shield

Right Shield

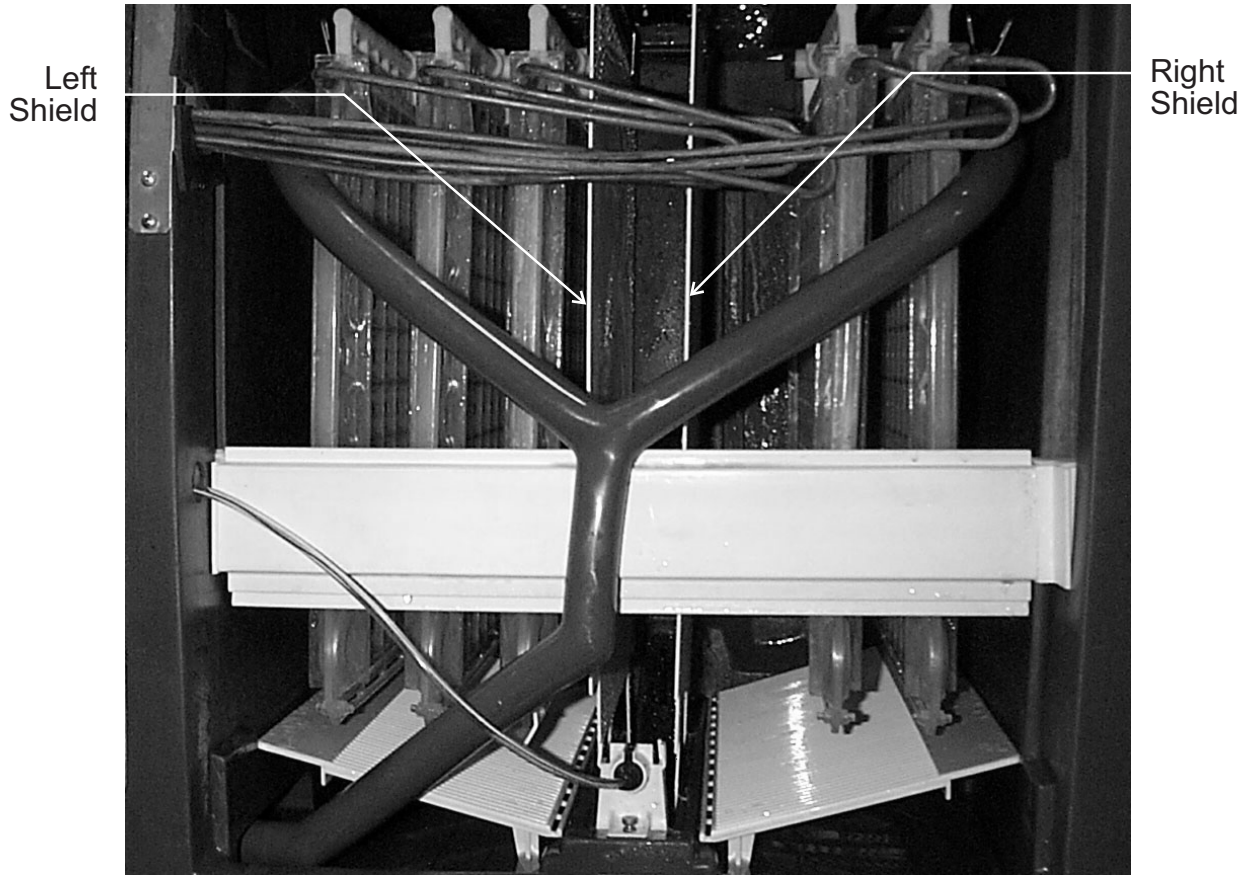

Front View, Shown With Shields in Place

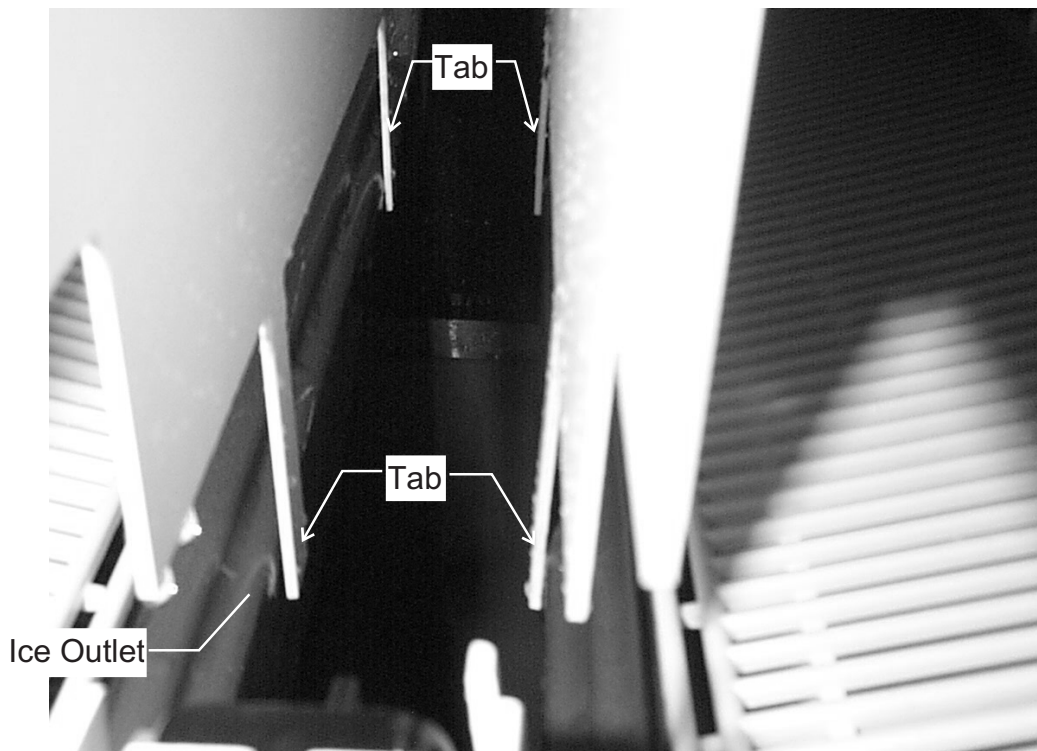

Note: Tabs on Shields Must Be Inside The Ice Outlet Port

9. Place a bead of food grade sealant onto the top left edge of the freezing compartment.

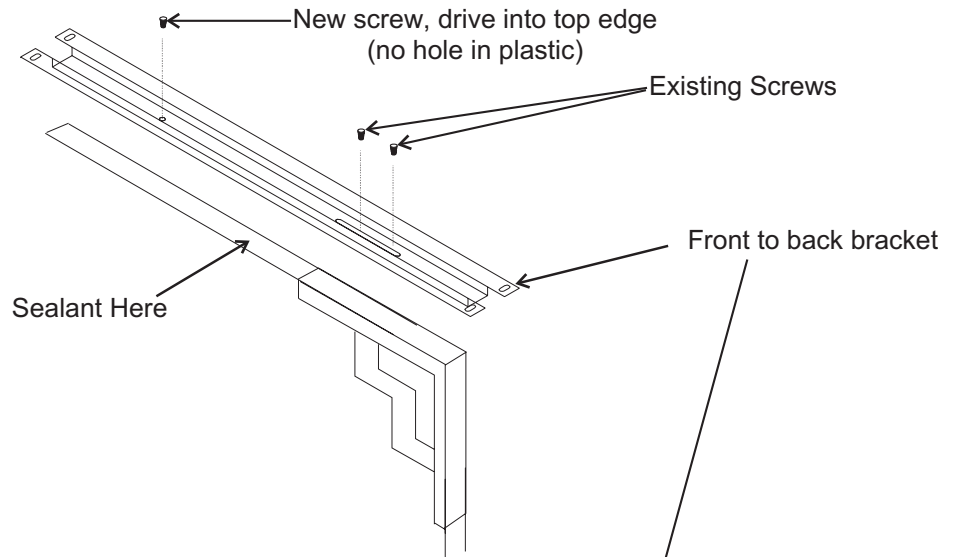

10. Install the front-to-back support bracket over the left edge of the freezing compartment.

Remove two existing screws and secure the bracket to the:

- freezing compartment,
- back panel and
- front channel

with the 2 existing screws and 1 large and 4 small screws from the kit.

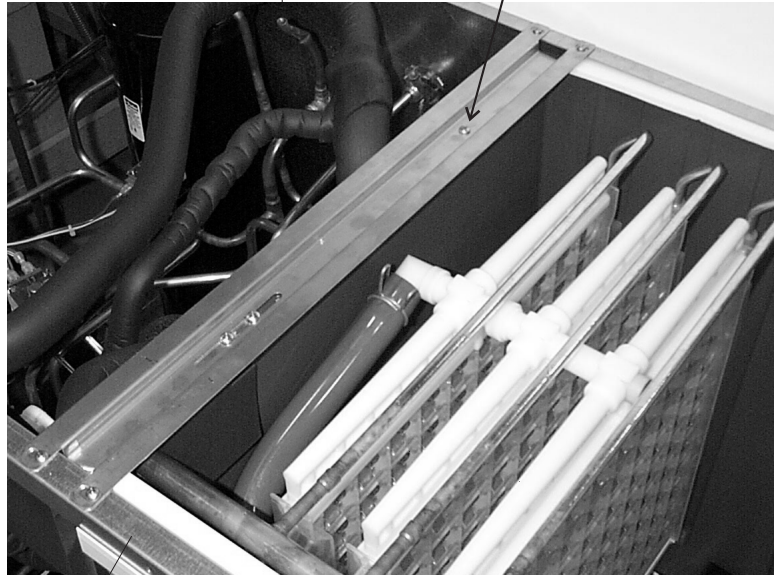

Front Channel

Bottom Machine:

11. Apply remaining gasket to the top edges of the

- Front-to-back support bracket,
- left side channel,
- front channel.

12. Place one layer of gasket on the top metal edges of the bottom ice machine - including the back and the right side panels.

Apply Gasket to Bottom Unit Freezing Compartment and Panel Top Edges

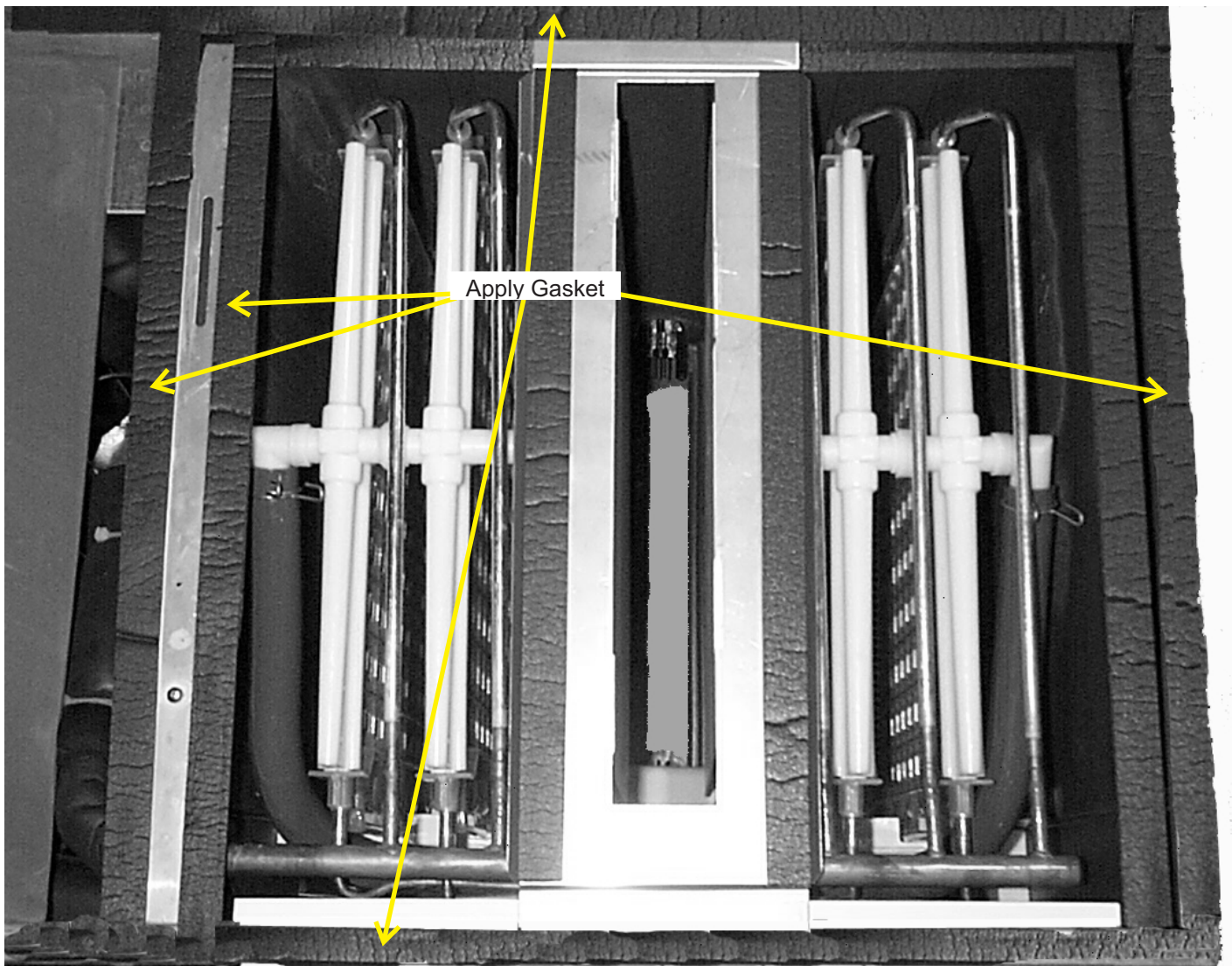

Both Machines:

13. Place the top ice machine onto the bottom one. Secure together with hardware from the top machine. Remove left front and left side panels.

14. At the back of the ice machines, on the compressor end, remove the upper knock-out from the bottom machine and the lower knock out from the upper machine.

15. Place a strain relief (from the kit) into each hole.

16. Insert wire harness from kit thru strain-relief and hole in upper corner of the lower ice machine's back panel.

NOTE: Harness is marked which end goes to which machine.

Bottom Machine:

17. Remove harness from controller terminal 7 and bin thermostat.

18. Route wire harness in lower ice machine to the controller. Connect to terminal #7. Plug the two free wires onto the thermostat terminals #1 and #2.

19. Return left side panel to its original position on the lower ice machine.

Top Machine:

20. Remove harness from controller terminal 7.

21. Route wire harness thru upper unit's lower knock-out hole and strain relief and continue internally to the controller. Plug wire onto terminal 7 of the controller.

22. Return all panels and covers to their normal positions.

23. Complete the balance of the installation.

Lower Unit
Knock Out

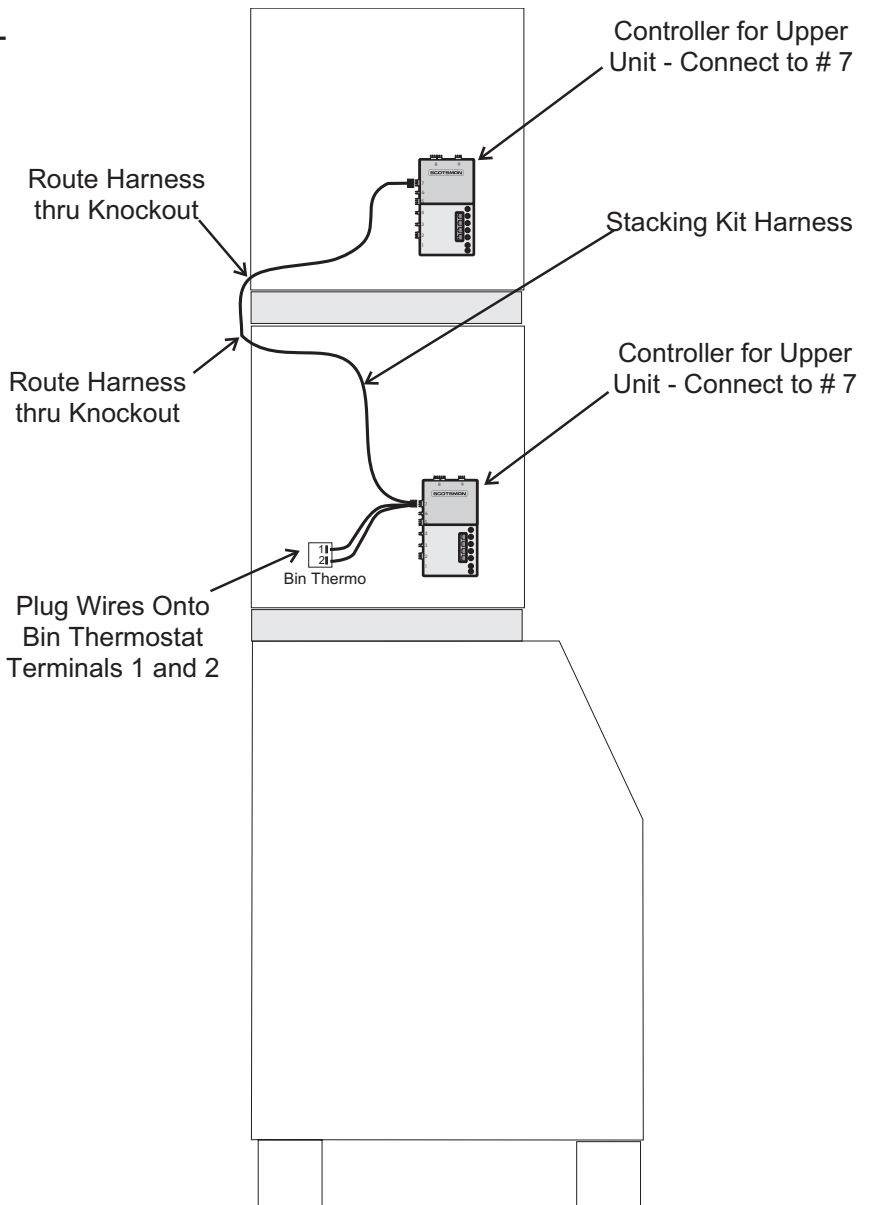
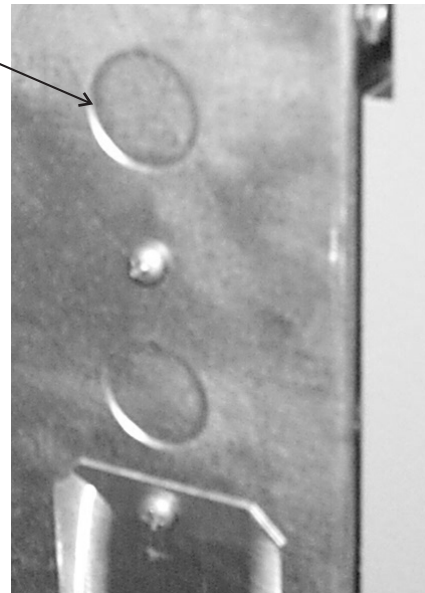

Service Notes:

A. The shields must be positioned so they hang vertically and move freely left to right. Their purpose is to guide the ice past the bottom machine's evaporators and into its cube port.

B. The drain lines from each ice machine must be kept separate.

C. If a shield must be replaced,

1. Remove the lower unit's front ice sensor.
2. Remove the old shield by lowering it through the ice outlet port.
3. Insert the new one by raising it from the bin through the ice port.
4. Return the lower unit's ice sensor to its original position.

Service Parts:

Bracket	A37935-001
Harness	12-2699-01
Left Shield	02-3885-02
Right Shield	02-3885-01