

CMS1402R SERVICE PARTS

This parts lists shows the service parts for the CMS1402R Remote.

Check the model number of the machine to be certain of obtaining the correct part.

A B model was introduced in early 1992. The major differences between A and B are the front panels.

Included at the back of the parts list are the wiring diagrams.

Table of Contents

Cabinet	Page 2
Refrigeration System	Page 3
Water System	Page 4
Control Box	Page 5
Remote Condenser	Page 6
BH900 Bin	Page 7
Wiring Diagrams	Page 8

CMS1402R SERVICE PARTS

CABINET PARTS

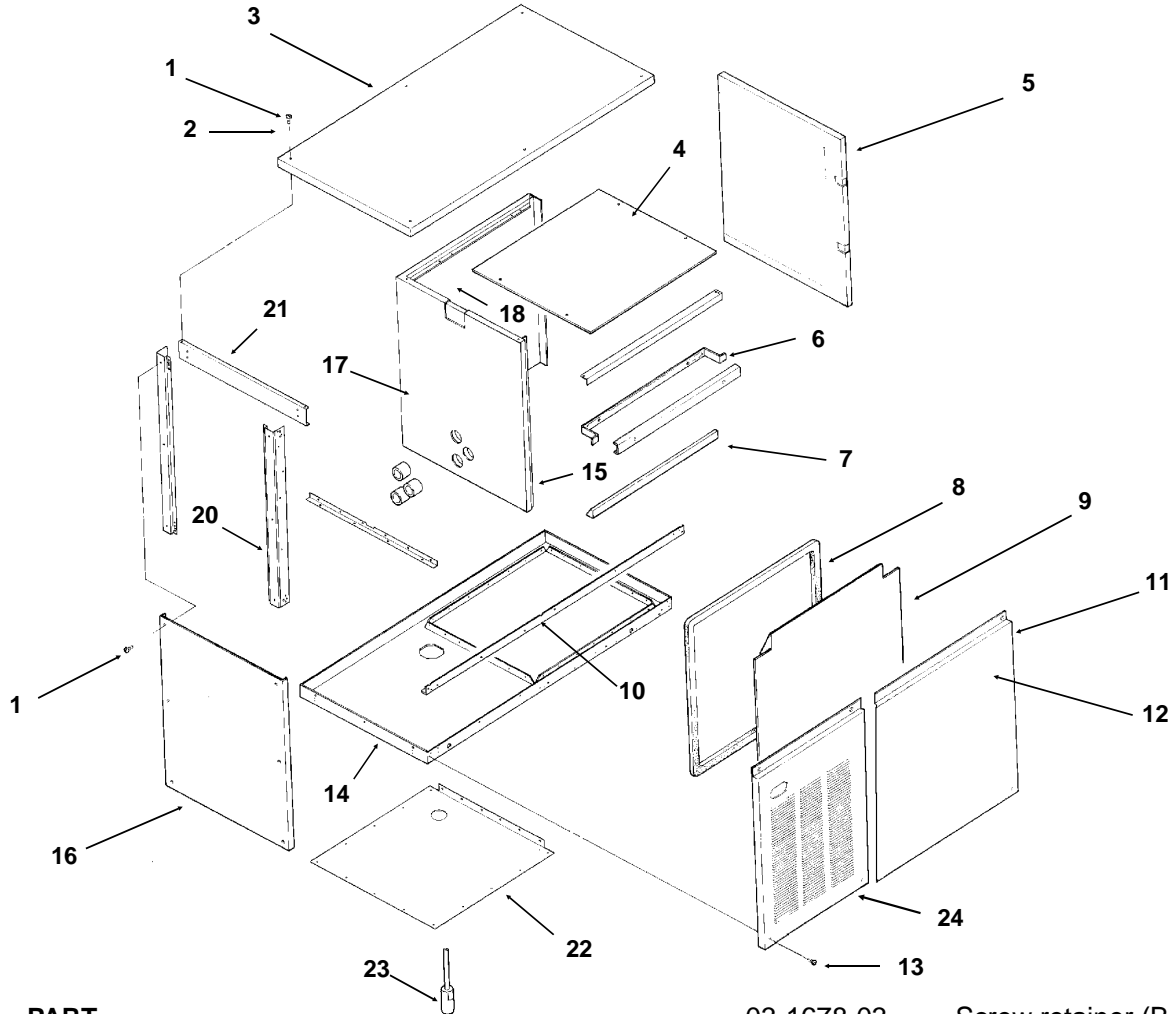

ITEM NUMBER	PART NUMBER	DESCRIPTION			
1	03-1531-01	Screws	12	03-1678-03	Screw retainer (B model)
2	03-1417-27	Washers	13	02-3252-01	Plastic bumper (B model)
3	A35074-001	Panel top (enamel)	14	15-0711-01	Emblem
	A35074-002	Panel top (stainless)	15	03-1404-19	Screws
4	A33364-001	Liner top	16	A35110-001	Base assembly
5	A29164-003	Right panel (enamel)		02-2533-01	Liner, left side
	A29164-002	Right panel (stainless)	17	A35075-001	Left side panel, enamel
6	A29204-001	Brace front	18	A35075-002	Left side panel, stainless
7	02-2532-01	Liner cap	19	no number	Retainer
8	13-0595-00	Gasket (order per foot)	20	02-2531-01	Liner back
9	02-2795-01	Liner, front panel	21	02-2534-01	Right side liner
10	03-1678-01	Speed clip (B model)	22	A35069-001	Corner post
11	A35080-021	A model front panel (enamel)	23	A35066-001	Brace
	A35080-022	A model front panel, (stainless)	24	02-3151-01	Plastic cover
	A35401-022	B model right front panel, stainless		A34908-021	Transducer
	A35401-021	B model right front panel, painted		A35400-001	B model left frnt pnl, painted
		Front panels include insulation and liner.		A35400-002	B model left frnt pnl, stainless
	03-1678-04	Thumb screw (B model)		03-1678-02	Panel screw (B model)
				02-3252-01	Plastic bumper (B model)

CMS1402R SERVICE PARTS

REFRIGERATION SYSTEM

ITEM NUMBER	PART NUMBER	DESCRIPTION	ITEM NUMBER	PART NUMBER	DESCRIPTION
1	A35122-001	Evap. manifold assy	17	12-2135-22	Hot gas valve
2	A31816-001	Manifold assy		02-3231-03	Hot gas valve screen
3	16-0816-21	Expansion valve	18	16-0817-21	Accumulator
	13-0617-51	O-Ring	19	16-0560-00	Valve core
	02-2920-01	Foam insulation	20	16-0563-00	Valve cap
4	12-2274-01	Liquid line solenoid valve	21	12-2300-07	Hi temp cut out
5	02-3319-02	Drier	22	A30296-020	Evaporator plate
6	16-0761-01	Receiver	23	16-0850-01	Discharge quick connect
7	A35072-001	Receiver bracket	24	16-0850-03	Liquid quick connect
8	03-1410-06	Lockwasher	25	A35070-001	Back panel
9	03-1406-13	Nut	26	11-0446-25	Hi pressure cut out
10	11-0422-22	Head pressure reg. valve	27	11-0467-21	Pump down control
11	03-1405-20	Screw	28	16-0790-01	Distributor, included in item 1.
12	03-1407-07	Washer	29	16-0823-01	Fusible plug
13	18-2200-28	Sleeve			
14	18-5100-51	Grommet			
15	12-2308-01	Crankcase heater			
16	18-8864-22	Compressor, single phase			
	18-8864-21	Compressor, three phase			
	12-2309-01	Crankcase heater clip			
	18-2308-01	Crankcase heater			
	no number	Comp. overload (internal)			

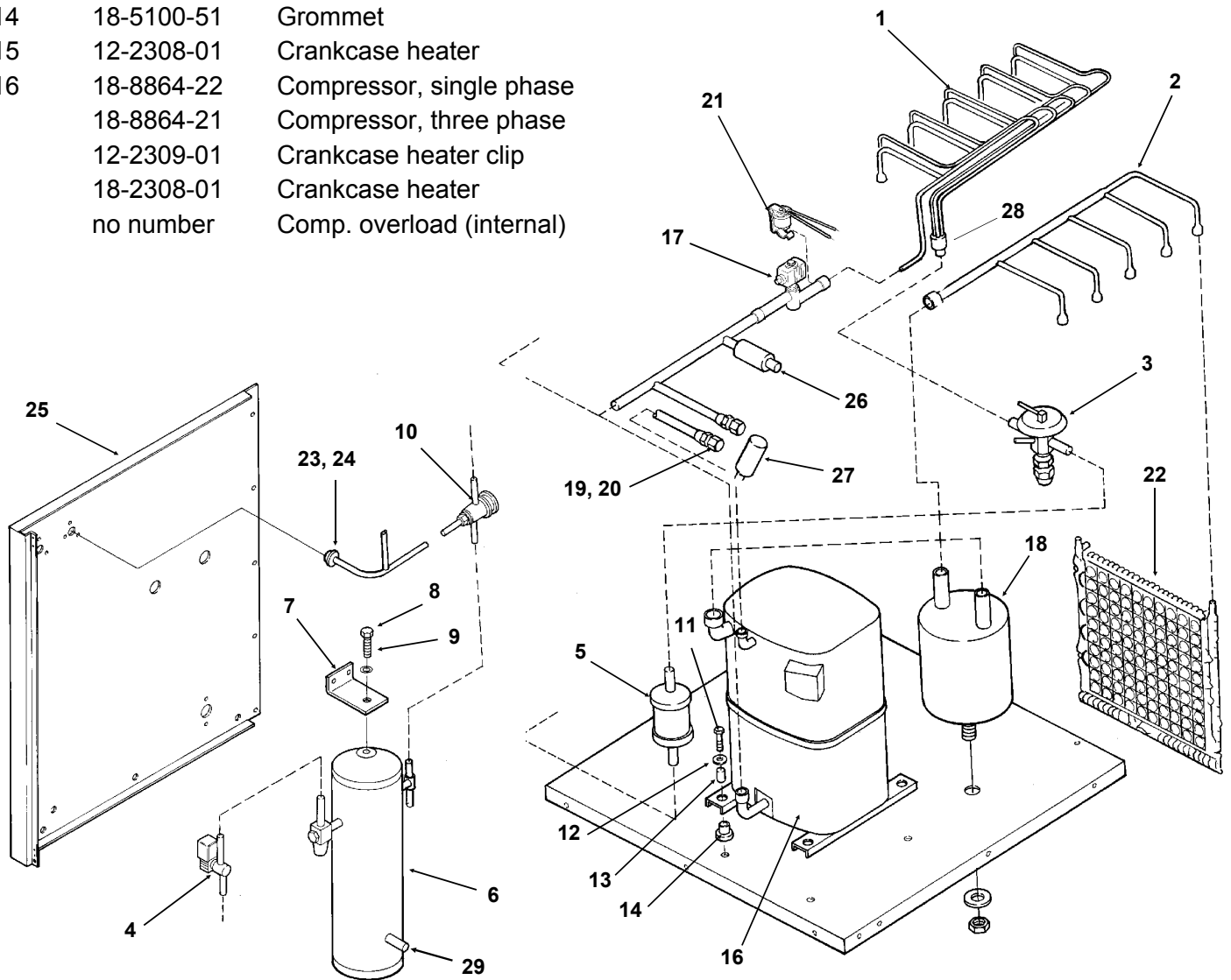

CMS1402R SERVICE PARTS

WATER SYSTEM

ITEM NUMBER	PART NUMBER	DESCRIPTION
1	02-2521-01	Long water manifold
2	02-2519-01	Tee
3	A29703-001	Short water manifold
4	02-2527-01	Water dist. tube
5	02-2814-01	Clamp
6	A29730-001	Water Tube Assy
7	A30761-020	Sump Assembly
8	02-1530-01	Clamp
9	02-2814-12	Clamp
10	A30666-001	Pump Bracket
11	03-0571-01	Screw

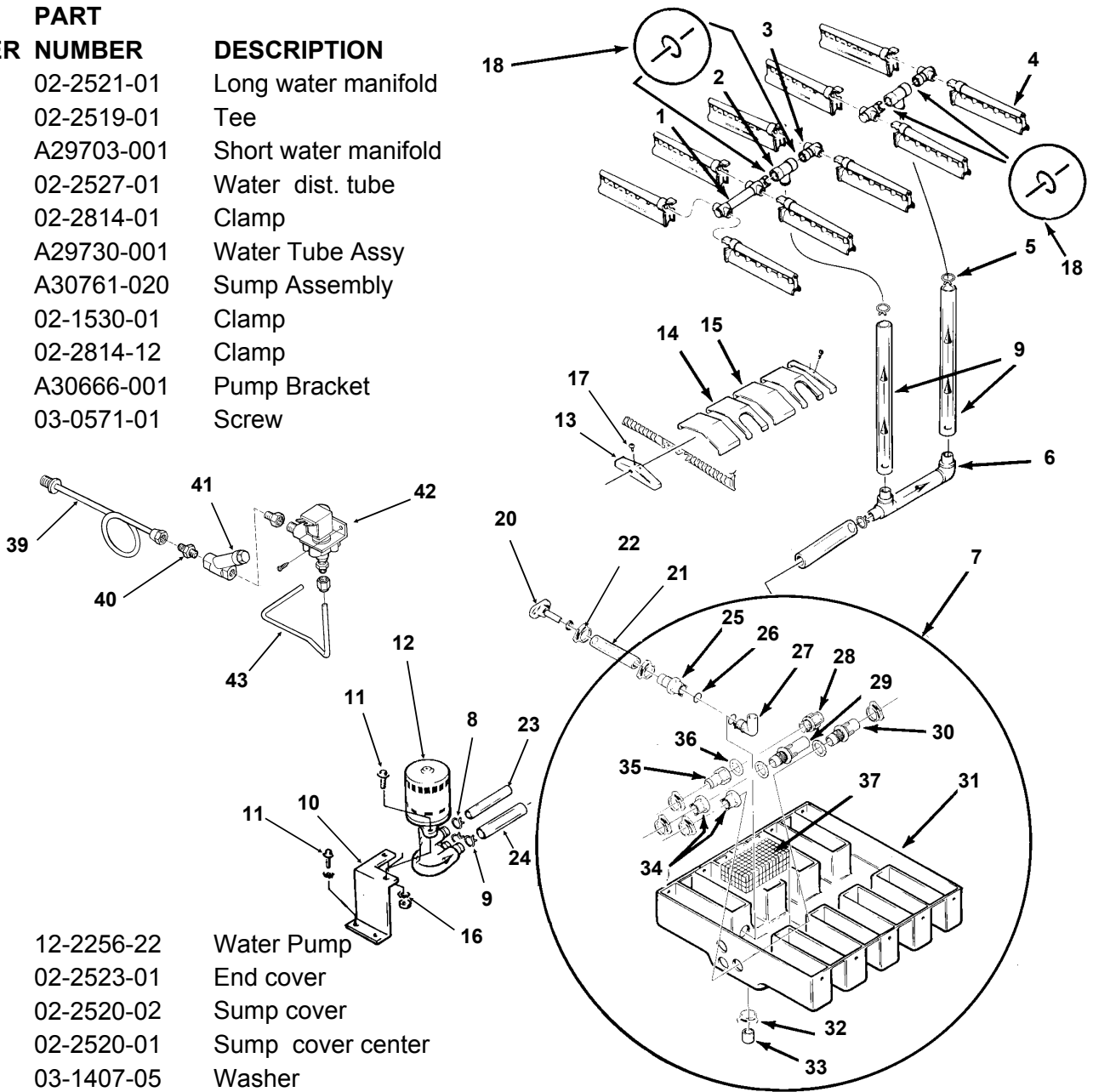

12	12-2256-22	Water Pump
13	02-2523-01	End cover
14	02-2520-02	Sump cover
15	02-2520-01	Sump cover center
16	03-1407-05	Washer
17	03-1531-01	Screw
18	13-0617-48	O-ring
19	13-0674-07	Hose (18.5")
20	A32282-003	Drain
21	13-0674-07	Tube, drain (7")
22	02-2814-12	Hose clamp
23	13-0674-07	Tube, need 6.25"
24	13-0674-08	Tube, need 6.6"
25	02-2606-01	Female tube
26	13-0617-02	O-ring
27	02-2125-01	Elbow
28	02-2080-01	Overflow
29	02-2792-01	Pick Up tube

30	02-2793-01	Inlet tube
31	no number	sump pan
32	02-1530-01	Clamp
33	13-0796-01	Rubber cap
34	02-2791-01	Water inlet nut
35	02-2606-01	Female tube
36	13-0617-02	O-ring
37	A30760-001	Screen
39	A35119-001	Water inlet assy.
40	16-0791-01	Half unio
41	16-0162-00	Strainer
42	12-1646-04	Inlet water valve
43	A35117-001	Tube

CMS1402R SERVICE PARTS

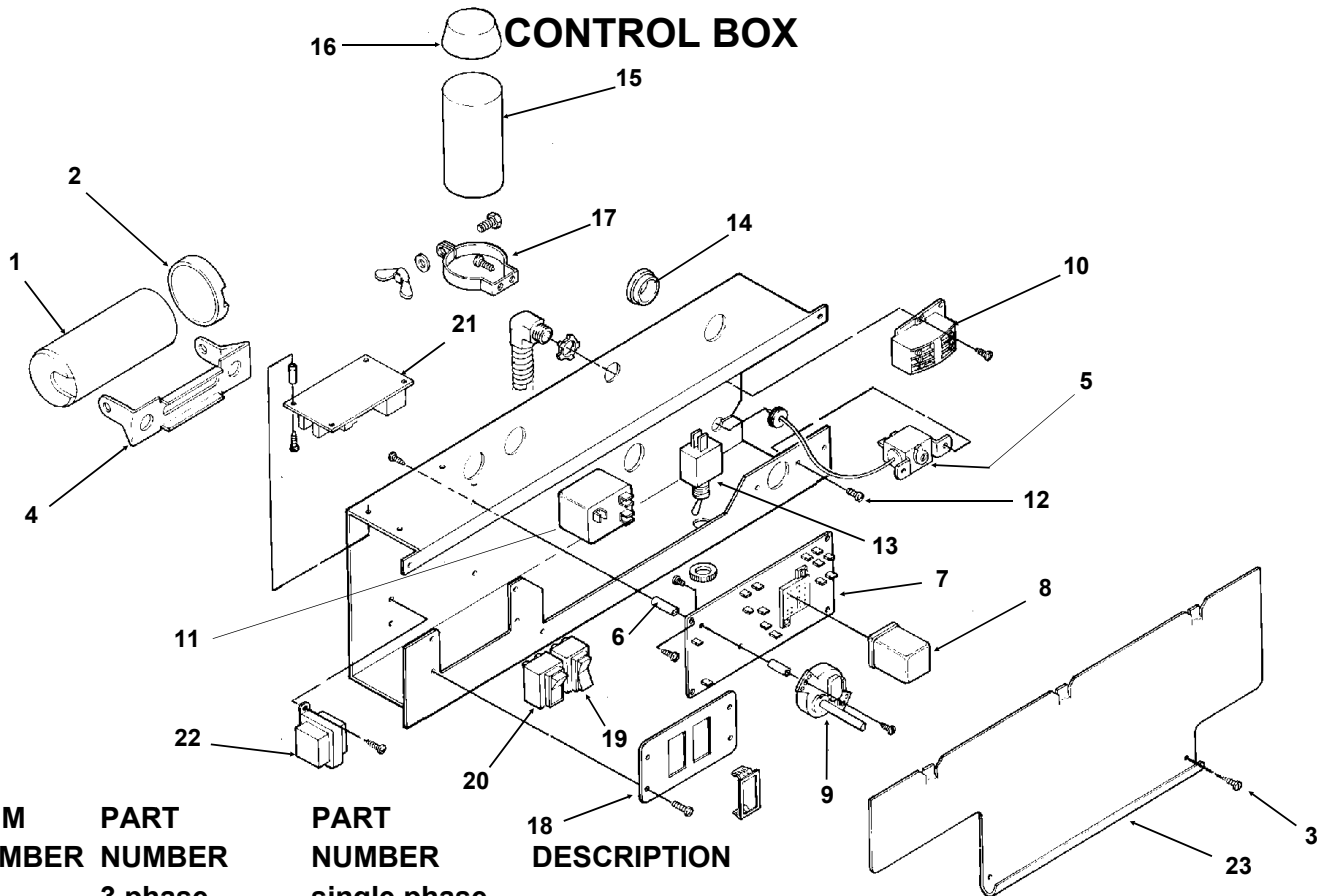

Note: Replacement Single Phase Compressor Starting Components:
 Scotsman began supplying a new replacement compressor in 2004, it uses these starting components.
 Item 1 same
 Item 11 18-1903-58
 Item 15 18-1902-60
 The new replacement compressor is Copeland number CR47KQ-PFV-280AB

ITEM NUMBER	PART NUMBER	PART NUMBER	DESCRIPTION
	3 phase	single phase	
1	-	18-1901-27	Start Capacitor
2	-	18-8702-01	Start Cap. Cap
3	-	03-1638-03	Screw
4	-	18-2200-39	Start cap. bracket
5	11-0351-22	same	Cube Size Control
6	02-2242-02	same	Stand off
7	12-1912-01	same	Circuit board
8	12-1879-03	same	Relay
9	12-2628-22	same	Timer & Switch
10	12-0739-02	12-2469-02	Contactor
11	-	18-1903-28	Potential Relay
12	03-1403-17	same	Screw
13	12-0426-01	same	Comp. Switch
14	-	12-1213-12	Snap busing
15	-	18-1902-27	Run capacitor
16	-	13-0666-00	Terminal cover
17	-	A34314-001	Run Cap Bracket
18	02-3173-01	same	Switich plate
19	12-2414-01	same	Wash- Off - Ice switch
20	12-2411-01	same	Bin ice level switch
		12-2402-01	Wire harness, bin level switch to board
21	12-2376-21	same	Ice level control circuit board
22	12-2285-22	same	Transformer
23	A35082-001	same	Control box cover

CMS1402R SERVICE PARTS

REMOTE CONDENSER

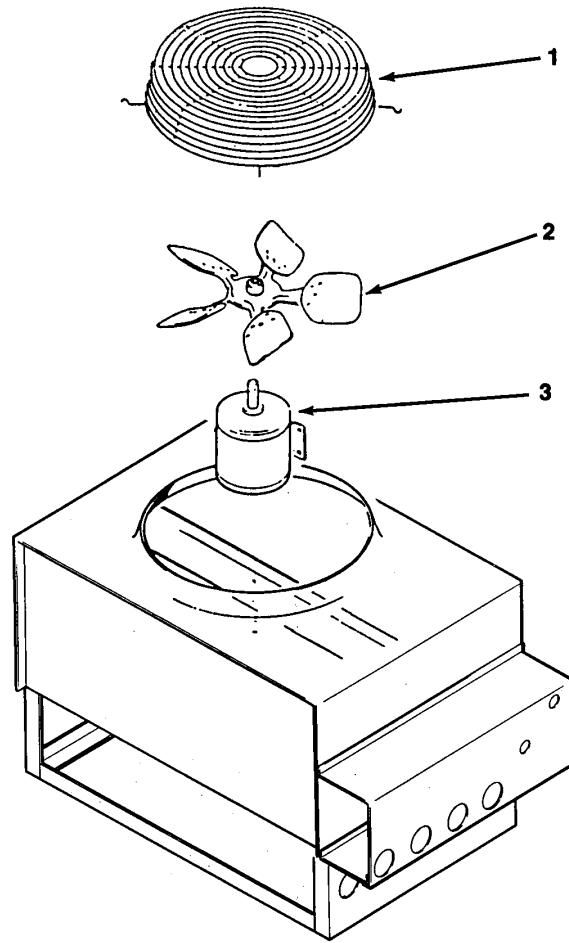

RC1422-32

ITEM NUMBER	PART NUMBER	DESCRIPTION
1	02-2618-01	Fan guard
2	18-6304-01	Fan blade
3	18-5301-01	Fan motor
Not Shown:		
4	16-0850-03	Quick connect, liquid
5	16-0850-01	Quick connect, discharge
6	16-1057-01	Quick connect, pre-charged 3/8" line
7	16-1057-02	Quick connect, pre-charged 1/2" line

CMS1402R SERVICE PARTS

BH900 ICE STORAGE BIN

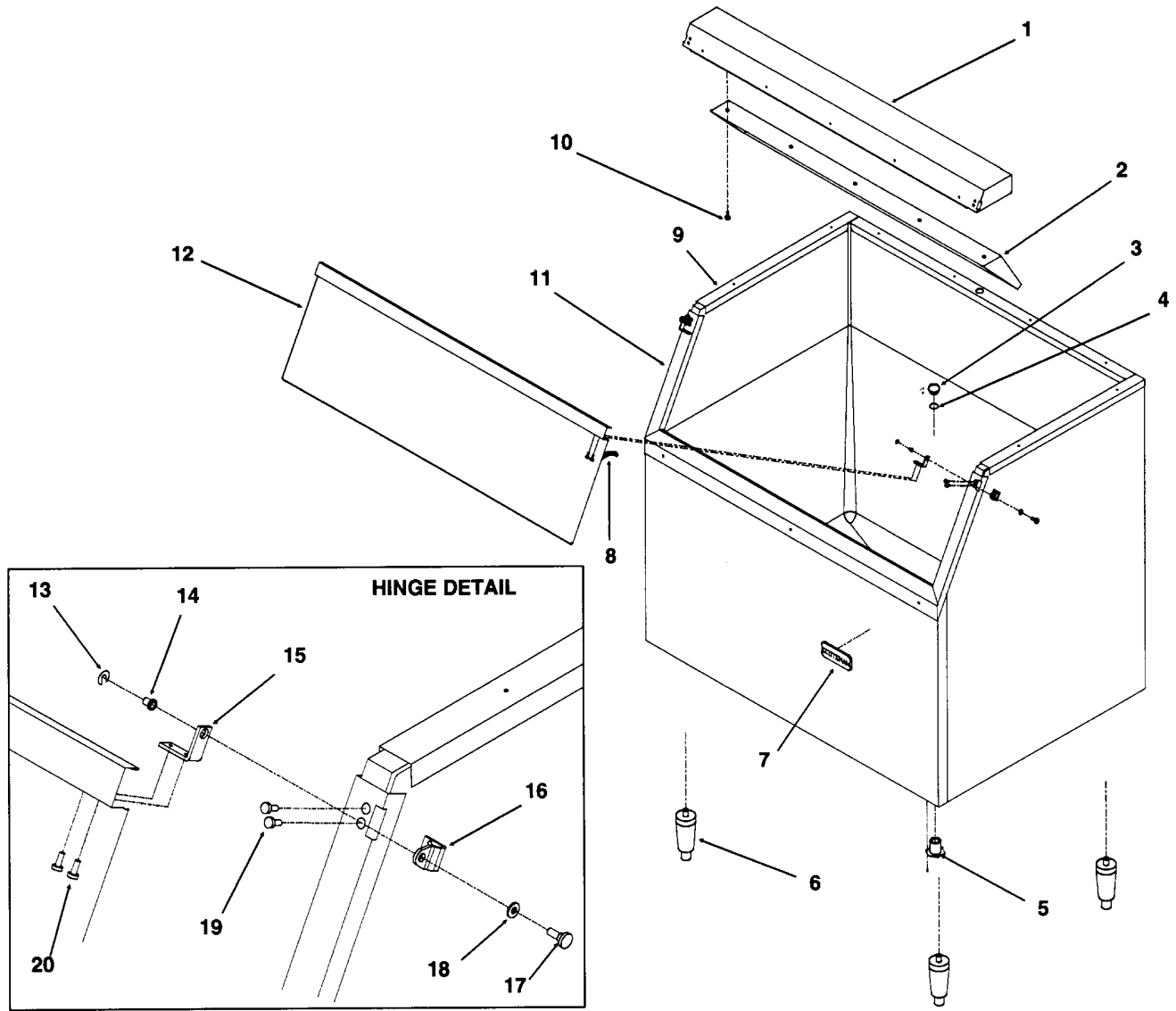

ITEM NUMBER	PARTS NUMBER	DESCRIPTION
1	A35322-020	Canopy Assembly
2	A35152-001	Ice Baffle
3	02-2809-01	Drain Top
4	13-0617-11	O-ring
5	02-3201-01	Drain casting
6	KLP2E	Leg Kit, Black
	KLP2S	Leg Kit, Nickel Plated
7	15-0711-01	Emblem
8	13-0595-00	Door gasket(6.25' reg.)
9	19-0503-04	Bin gasket
10	03-0727-11	Baffle screw
11	A35275-001	Door frame assy.
12	A35323-020	Door with gasket
13	03-1539-09	"E" ring

ITEM NUMBER	PARTS NUMBER	DESCRIPTION
14	02-2380-01	Hinge bushing
15	02-3195-01	Door hinge
16	02-3196-01	Bin hinge
17	02-2806-01	Shoulder screw
18	02-2380-02	Spacer
19	03-1403-29	Screw 10-24
20	03-1403-24	Screw 10-24
22	02-0540-00	Scoop

CMS1402R SERVICE PARTS

208-230/60/3

Remote Air Cooled

A35441-003

THIS UNIT MUST BE GROUND
USE COPPER CONDUCTORS ONLY

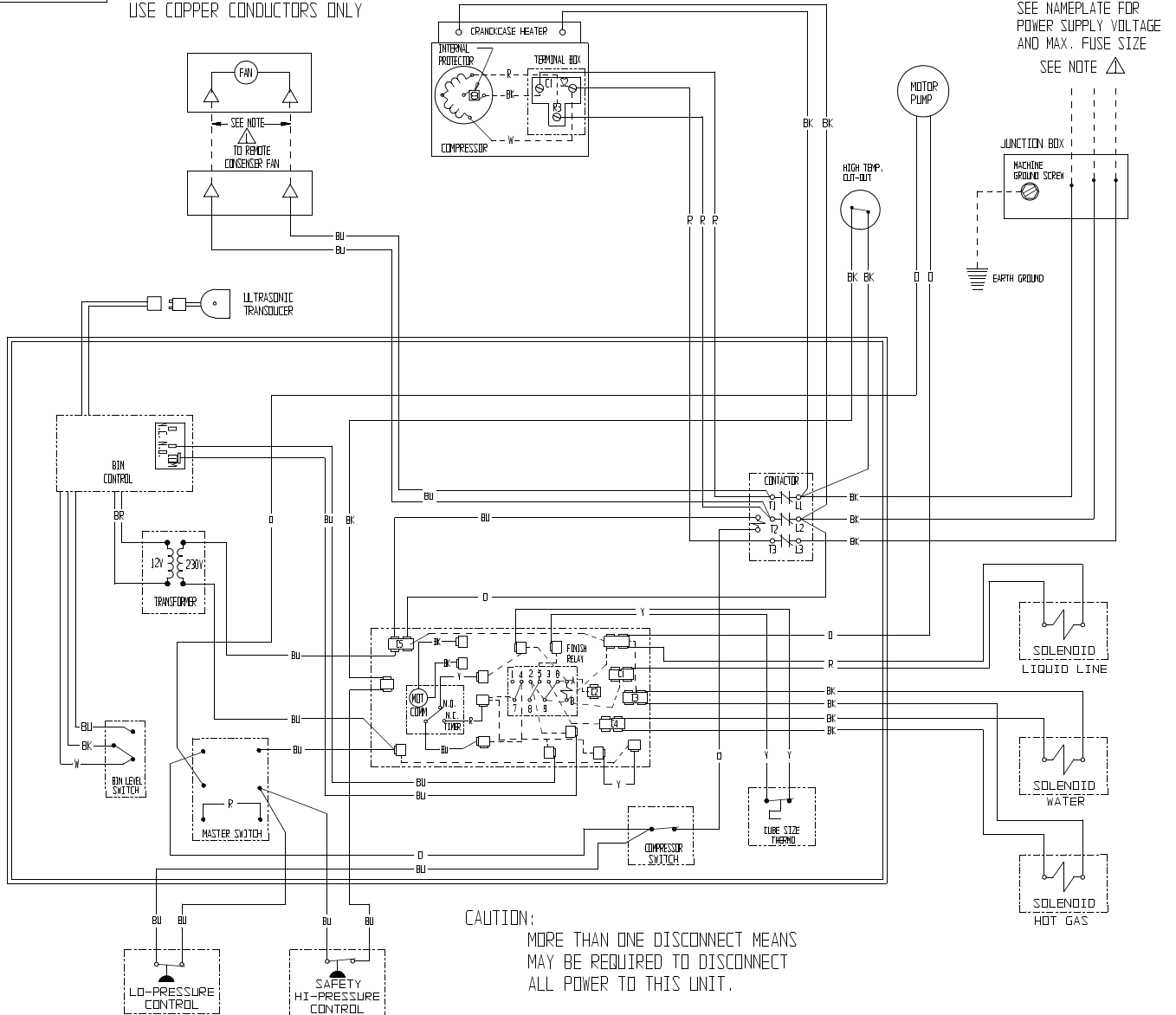

CMS1402R SERVICE PARTS

208-230/60/3

Remote Air Cooled

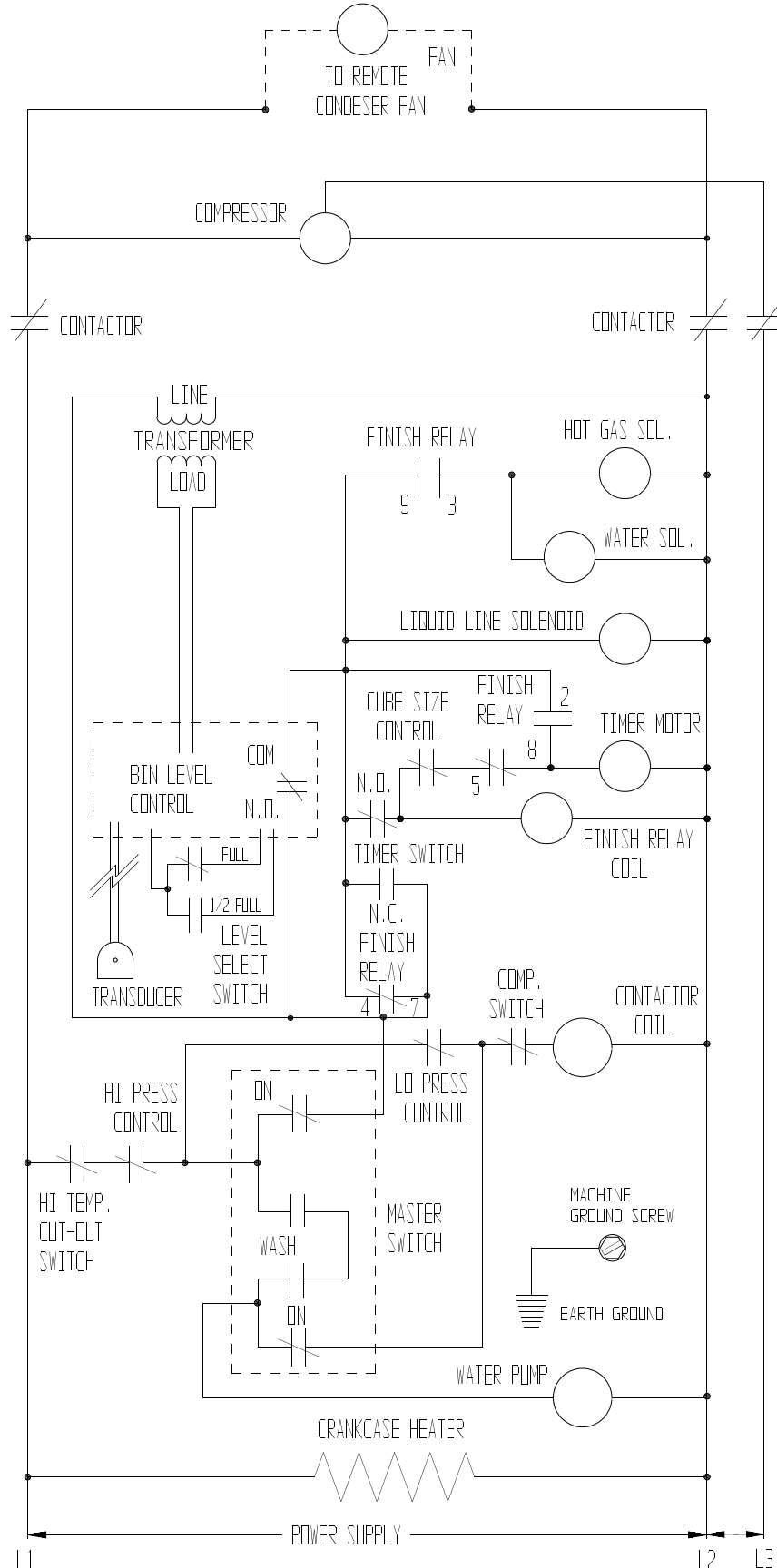

CMS1402R SERVICE PARTS

208-230/60/1

Remote Air Cooled

NOTE:
 ▲ DASHED LINES INDICATE FIELD WIRING WHICH MUST BE
 INSTALLED IN ACCORDANCE WITH THE NATIONAL ELECTRICAL
 CODE AND ALL STATE AND LOCAL CODES.

THIS UNIT SHOWN IN THE TIMED PORTION
 OF THE FREEZING CYCLE

THIS UNIT MUST BE GROUNDED
 USE COPPER CONDUCTORS ONLY

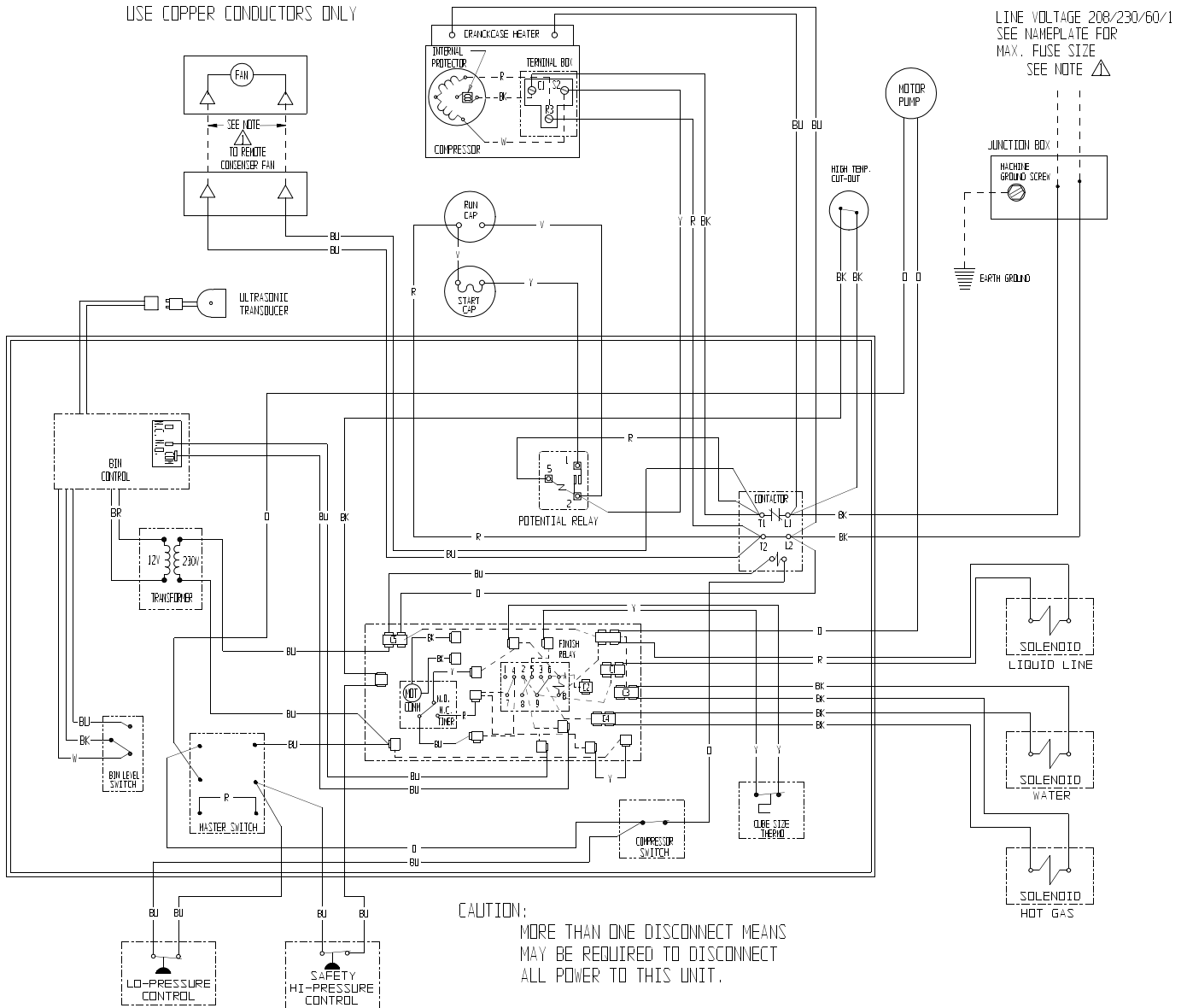

CMS1402R SERVICE PARTS

208-230/60/1

Remote Air Cooled

