

Scotsman®

Technical Review

of a

Remote Condenser Cuber

with

Enhanced Refrigeration and Water Systems

using

CM³

Technology

models included are:

**CME456,
CME1056,
CME1356,
CME1656 and
CME2006**



CME1356 shown on BH900

New Remote Cuber Technical Review

Freeze Cycle

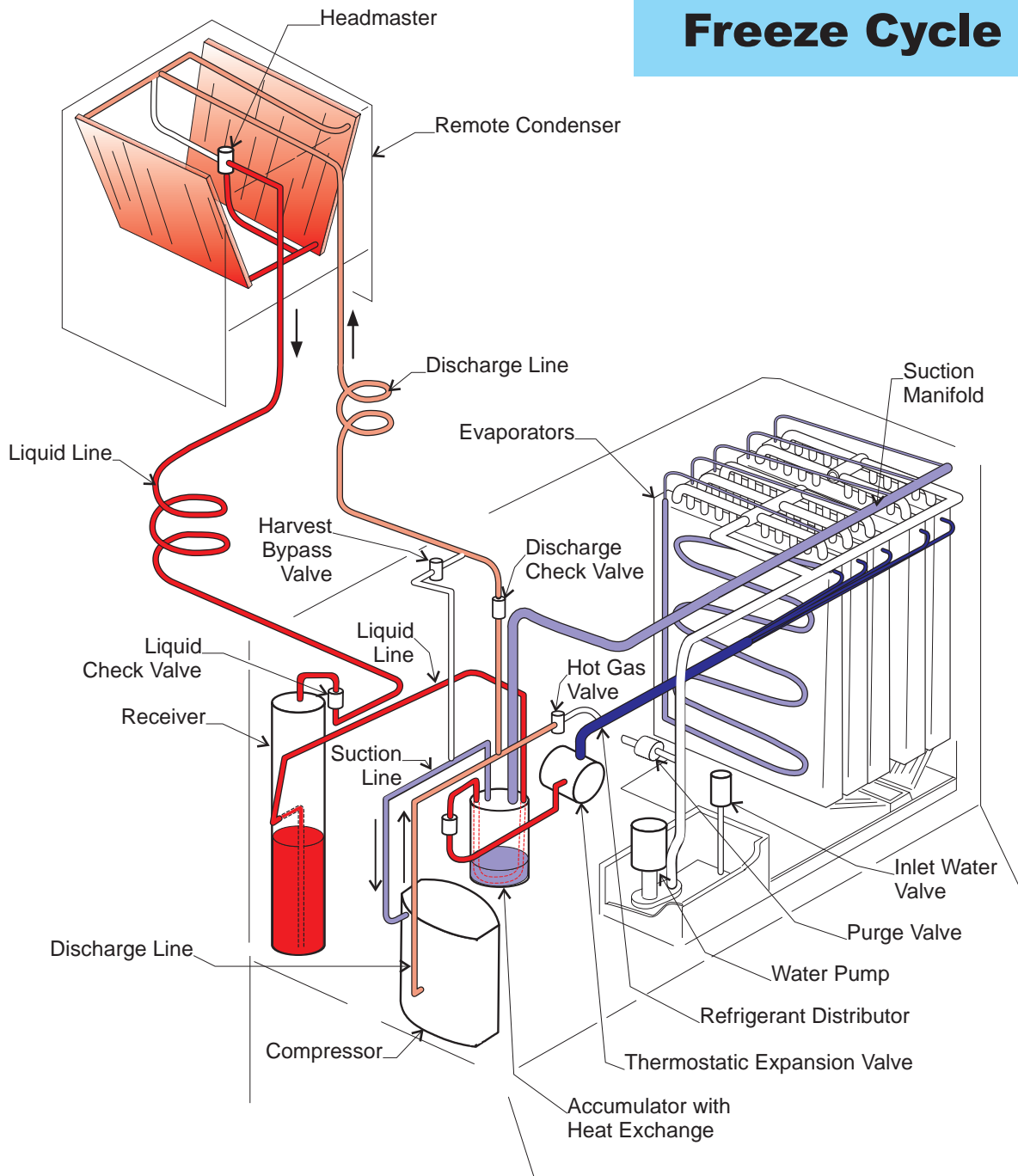

Scotsman's new enhanced refrigeration system has been designed to deliver long term reliability as well as competitive performance. Combined with the state of the art CM³ control system, this new remote Scotsman cuber will consistently deliver ice under a very wide range of conditions.

While in a Freeze Cycle in typical summer conditions, the refrigeration system operates much like a self contained air cooled - except that it exhausts the heat outside the ice machine cabinet.

New Remote Cuber Technical Review

Freeze Cycle - Cold Ambients

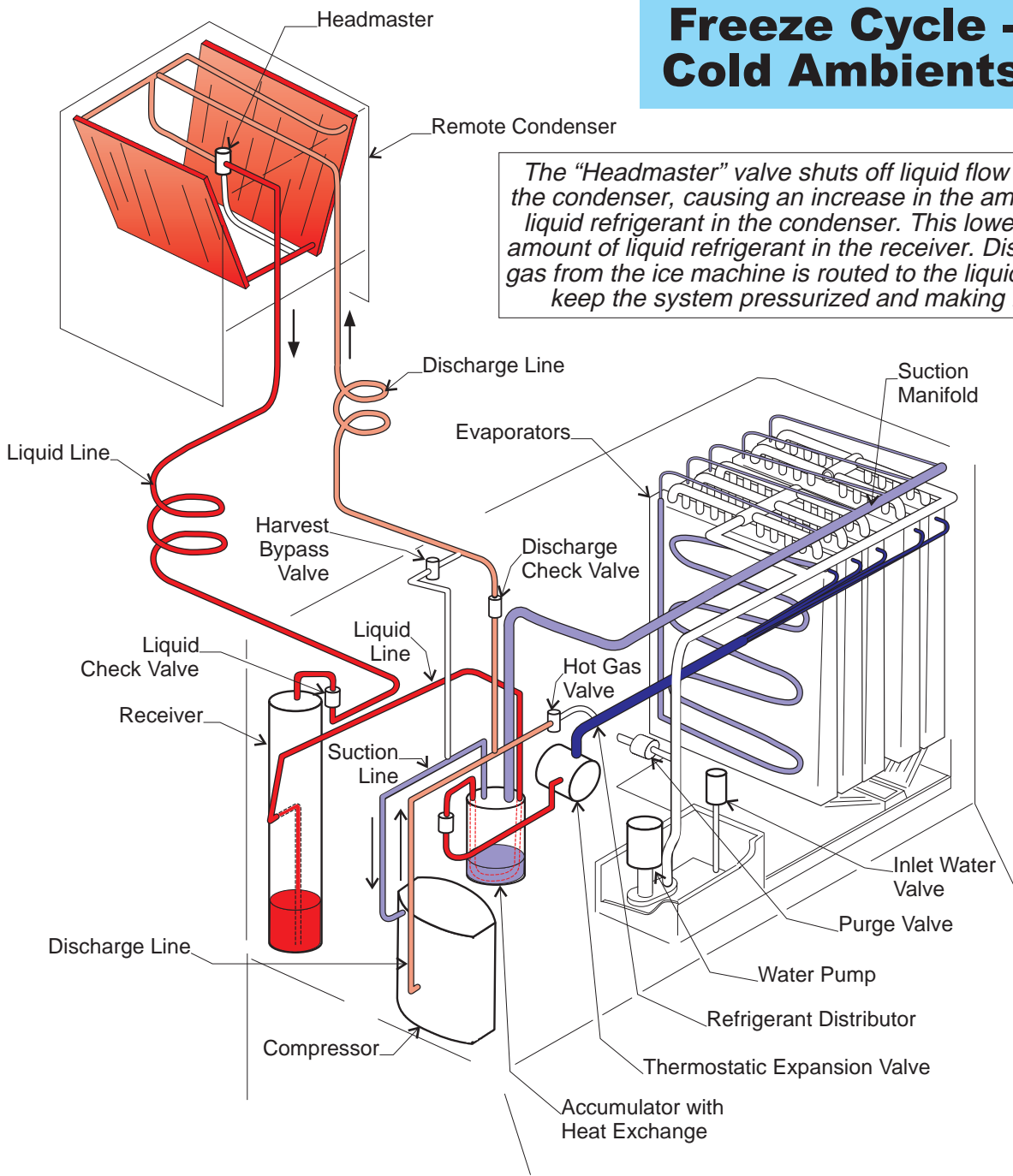

The "Headmaster" valve shuts off liquid flow out of the condenser, causing an increase in the amount of liquid refrigerant in the condenser. This lowers the amount of liquid refrigerant in the receiver. Discharge gas from the ice machine is routed to the liquid line to keep the system pressurized and making ice.

Remote systems function like regular air cooled models under warm conditions. It's when the temperatures get cold that the system must change to keep ice flowing into the bin.

When the remote condenser operates in cold air, the machine adjusts for that in part by limiting the amount of refrigerant that will be used during a harvest cycle. Additionally there is a "headmaster" valve in the condenser. During the Freeze cycle it maintains a minimum discharge pressure - even when the condenser is operating in a sub-zero environment. Maintenance of a minimum discharge pressure allows a remote condenser ice machine to continue to make ice under extreme low temperature conditions.

New Remote Cuber Technical Review

Beginning Harvest Cycle

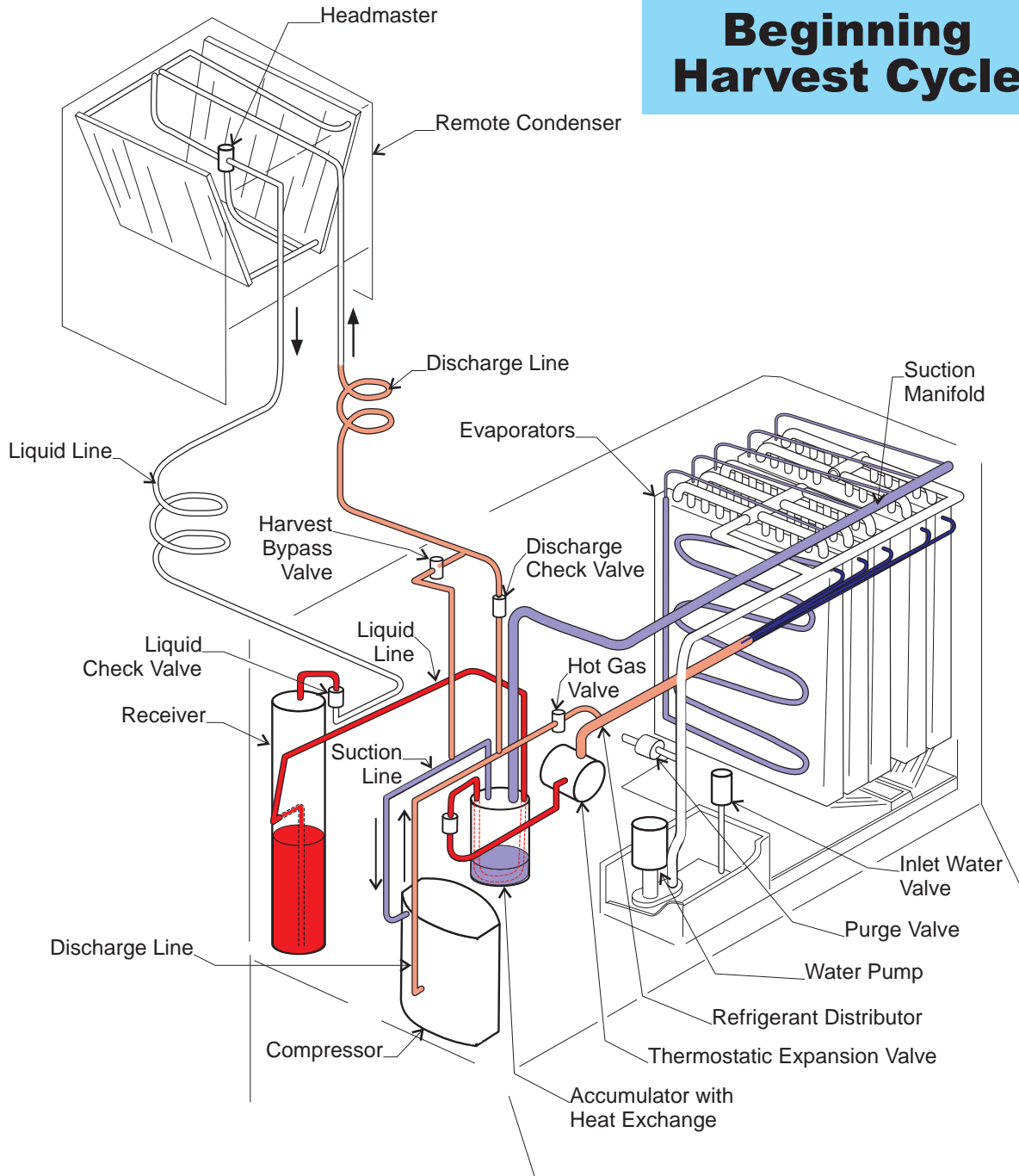

This system uses check valves to keep some of the refrigerant in the condenser, containing the cold refrigerant where it cannot take heat away from the hot gas used for harvest. This also keeps the compressor, and its oil, warmer, which improves compressor reliability.

Because some additional refrigerant is needed during harvest, a by-pass solenoid opens for a few seconds to inject a small amount of discharge gas refrigerant into the suction side, where it is used by the harvest system.

New Remote Cuber Technical Review

Harvest Cycle

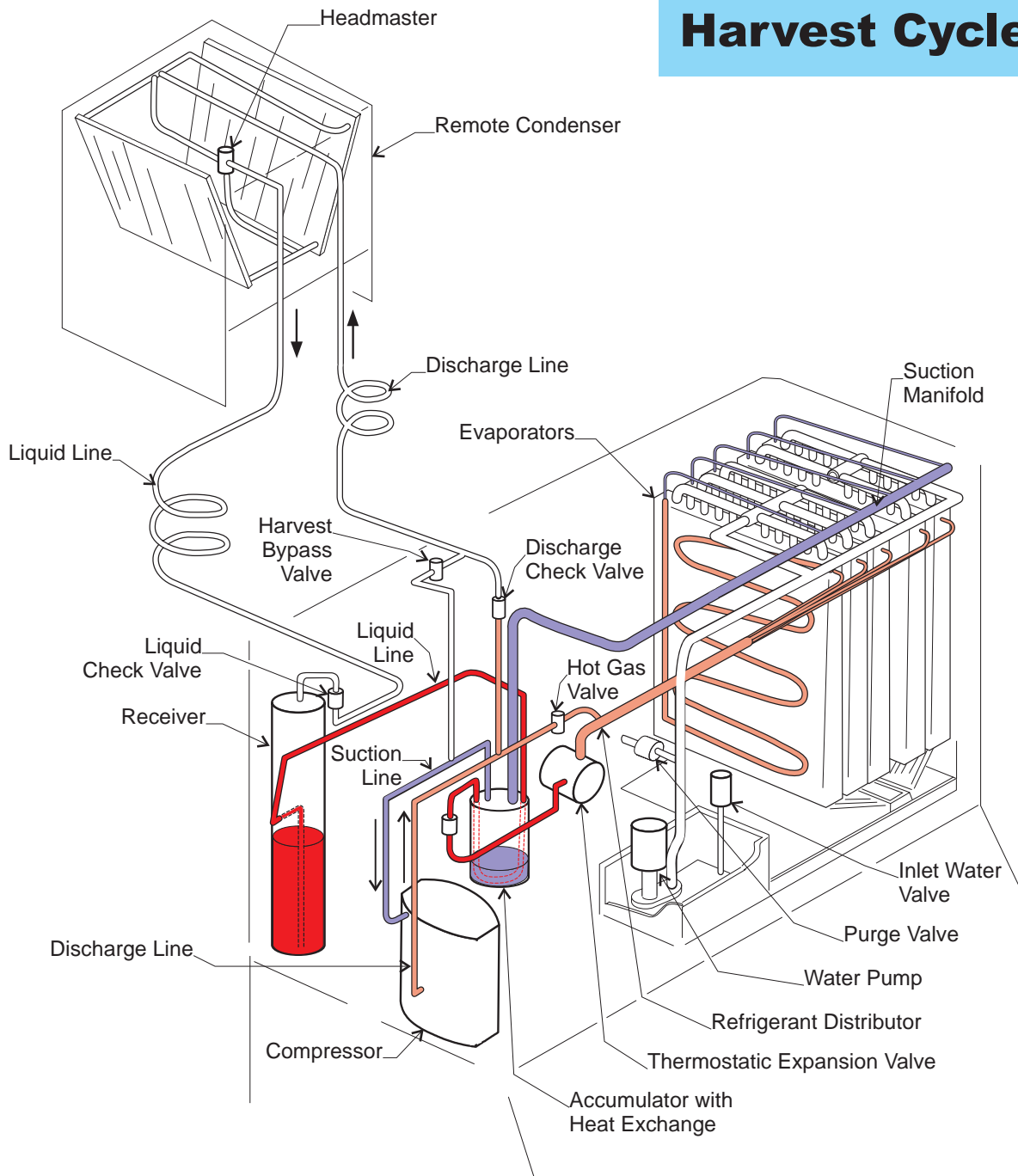

During harvest the hot gas valve opens and hot gas flows into the side port of the refrigerant distributor and then to the evaporator inlets. When the bin has been filled, and the machine is shutting down, rather than use a complex pump down system, the cuber simply starts a short freeze cycle and then shuts off. This moves almost all refrigerant to the receiver for storage and returns oil to the compressor.

Another feature that enhances reliability is the continuous operation monitor. If the machine has been in operation continuously for more than 15 cycles, the controller extends the next harvest cycle a bit to rebalance the system. After that it returns to normal operation.

New Remote Cuber Technical Review

Component Description

Component's Name	Component's Function
Purge Valve	Opens to drain the reservoir at the beginning of the harvest cycle.
Inlet Water Valve	Opens to fill the reservoir.
Liquid Line Check Valve	Open during freeze, it closes when harvest begins to prevent refrigerant from flowing to the condenser.
Discharge Line Check Valve	Typically open, it closes during the harvest cycle and the off cycle to prevent refrigerant from flowing back into the compressor.
Harvest By-Pass Solenoid Valve	Normally closed, it opens for a few seconds at the beginning of harvest to inject condenser refrigerant into the hot gas harvest circuit.
Hot Gas Valve	Normally closed, it opens during harvest to warm the evaporators.
Refrigerant Distributor	Directs liquid refrigerant flow to the evaporators during freeze and hot refrigerant gas to the evaporators during harvest.
Headmaster	Usually not in the refrigeration circuit, but blocks liquid flow out of the condenser when discharge pressure falls below a minimum point.
System Controller	Controls the ice machine's operation; accepts input data from several sensors and switches various loads on and off to make and harvest ice. Also controls the continuous operation monitor.
Bin Thermostat	Signals to the controller when to switch ice making on and off.
Ice Sensors	Signals to the controller when ice is being harvested.
Water Level Sensor	Signals to the controller the water level in the reservoir.
Water Temperature Sensor	Signals to the controller the temperature of the water being pumped.
Discharge Temperature Sensor	Signals to the controller the discharge line temperature.

New Remote Cuber Technical Review

Key Components



Purge Valve

The **purge valve**, located just above the water reservoir, controls the draining of water from the reservoir.

When it is open and the water pump is on, water flows through this valve to the ice machine's drain.

Regular draining of the reservoir dilutes the amount of mineral scale in the reservoir's water, and that reduces the impact of mineral-laden water supplies on the operation of the ice machine.

The amount of water purged is adjustable to accommodate local water conditions.

The **harvest bypass valve** is only open for a few seconds each harvest cycle. The purpose of this valve is to add only the necessary amount of refrigerant to the harvest circuit to promote a good release of ice.



Harvest Bypass Valve

There are two **check valves**, a liquid line check valve and a discharge line check valve.

During the off cycle, the liquid line check valve prevents refrigerant migration to the remote condenser from the receiver.

During the harvest cycle, the discharge line check valve separates the refrigerant in the condenser from the refrigerant in the harvest circuit.



Check Valve

New Remote Cuber Technical Review

Remote System Installation

Overall Installation

1. Select a good location for the condenser, line set and ice machine. Select the **minimum** length of precharged line set that will fit the application. Follow the recommendations in the manual supplied with the machine.
2. Follow all applicable building codes.
3. For roof-mounts, have a roofing contractor install and attach the condenser to the roof.
4. Have the roofing contractor also cut a properly sized hole in the roof. A separate hole may be required for the electrical power supply.

5. Route the precharged lines between the ice machine and the remote condenser.

6. Either coil up the excess tubing OR cut out the excess tubing.

7. Have a roofing contractor seal the hole(s)

8. Plan to and connect electrical power to the ice machine 4 hours before starting up the machine.

9. Open the liquid line shut off valve just prior to initial start up.

10. At initial start up, follow the directions in the manual supplied with the ice machine.

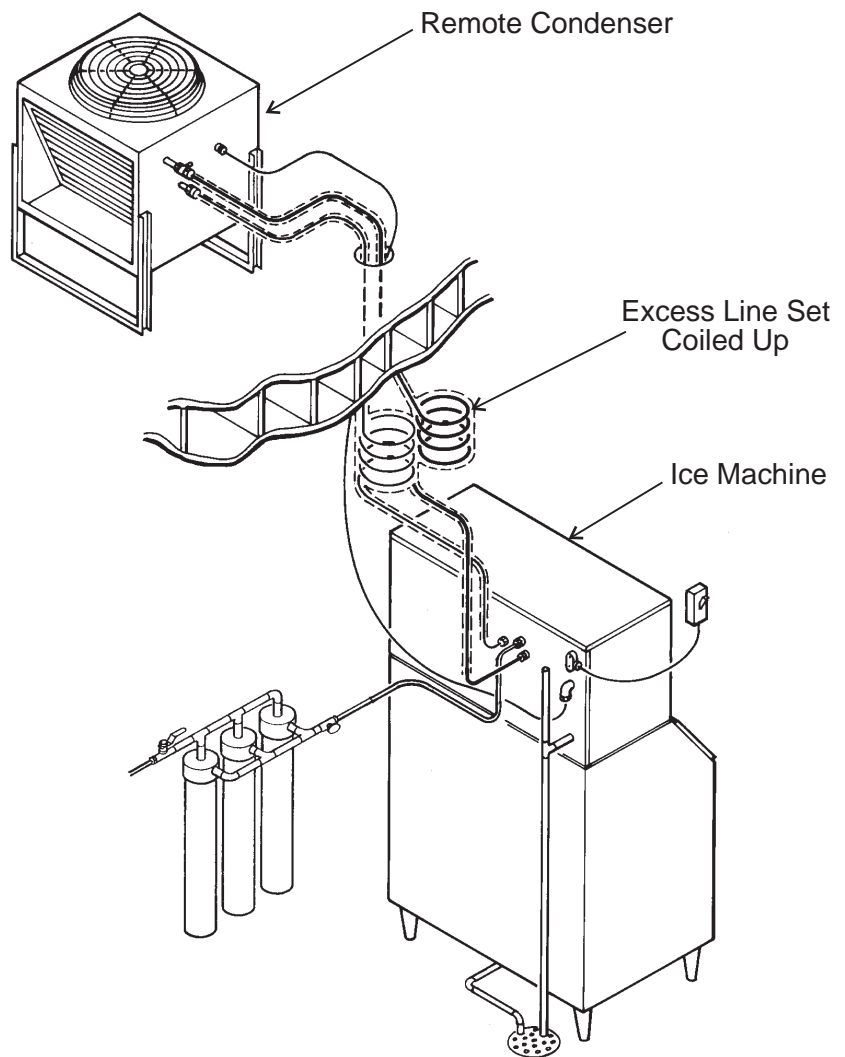

Typical Installation

New Remote Cuber Technical Review

Remote System Installation

Couplings:

1. Remove the protector caps and plugs. Wipe the seats and threaded surfaces with a clean cloth.

2. Thoroughly lubricate the threads, o-rings, diaphragms and all internal coupling surfaces with polyol ester refrigerant oil.

3. Position the pre-charged line couplings on the proper fittings of the ice machine and remote condenser.

4. Begin to tighten the couplings together by hand. Continue to turn the swivel nuts by hand until it is certain that the threads are properly engaged.

5. Using two wrenches, one to rotate the swivel nut and one to hold the tubing in place, tighten each coupling.

The diaphragms in the couplings are pierced as the swivel nut is turned. During the piercing it's normal for the swivel nut to become hard to turn.

Continue to tighten the couplings until it requires much more force to turn the nut, at that time no threads should be visible.

6. Mark the position of the swivel nut relative to the cabinet.

7. Rotate the swivel nut one quarter turn more to completely seal the connection.



Clean and Lubricate Couplings.



Tighten Swivel Nut



Rotate Swivel Nut ¼ Turn More

New Remote Cuber Technical Review

Initial Start



All lights blink once when power is re-supplied to a system controller that has been switched Off and disconnected from a power supply.

Pushing and releasing the Freeze button starts the machine.

If there is a power interruption, the freeze light will be blinking as the machine goes through a restart sequence. After a short freeze cycle and complete harvest, the unit will resume normal operation.

Beginning Freeze



Water enters the machine at initial start up and at the beginning of every freeze cycle to top off the water reservoir.

The Freeze cycle light will be On, and the compressor, water pump and fan motor will also be working.

Freeze Cycle



Early in the freeze cycle the controller activates an anti-slush cycle, during which the water pump stops for a short time and then restarts. This coats the evaporators with a thin layer of ice, preventing slush and improving water flow characteristics over the freezing surfaces.

The water reservoir will also be refilled one time about $\frac{1}{2}$ way through the freeze cycle.

New Remote Cuber Technical Review

Beginning Harvest



At the beginning of the harvest cycle, the water pump is off, the purge valve is open, but because the pump is off no water drains. After an amount of time determined by the purge setting, the pump restarts. After being open for 74 seconds, the purge valve closes.

The inlet water valve then opens and water flows in for a short time to supply water that will be used to assist harvest.

Harvest Cycle



Harvest continues until the controller determines that enough time has elapsed to release all the ice.

It does this by timing how long it takes from the beginning of harvest until the last cube has fallen through the ice sensor's "light curtain".

Shut-Down



When the bin thermostat is covered with ice, it closes its contacts, signaling the system controller that no more ice is needed. At the end of the next cycle, the ice machine goes through a short freeze cycle before shutting off.

It will not restart for 4 minutes even if the thermostat is immediately warmed up. The Bin Full light will be on during that time.

New Remote Cuber Technical Review

Cleaning



Cleaning begins with a push of the Harvest button to release any ice. After placing the ice sensors in the reservoir, push the Clean button and pour 24 ounces of Scotsman Ice Machine Cleaner into the reservoir. After 10 minutes push the Clean button again to start the rinsing process.

After 20 minutes, push the Off button to stop the machine. Put the ice sensors back in place and push the Freeze button to restart the machine.

Diagnostic Lights



The controller has two diagnostic lights that provide a technician guidance towards the cause of possible operational problems.

The water light will blink if water flow into the machine is too slow or non-existent. The refrigeration light will blink if no ice is harvested or the freeze cycle is too long.

There are differing blink rates for various issues. See publication 291-809 for details.

Adjusting Water Purge



The amount of water purge is adjustable. To do so, push and hold the Off button until the machine stops. Then push and hold the Off button again until the green lights glow.

The number of green lights glowing indicates the level of purge. To change the level of purge, push and release the Freeze button. Each push adjusts the purge one level higher.

When done, Push and release the Off button.