

GB/GT/T-250

KOLD-DRAFT

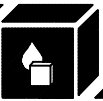

CLASSIC

T-260/AKD

Service and Parts Manual

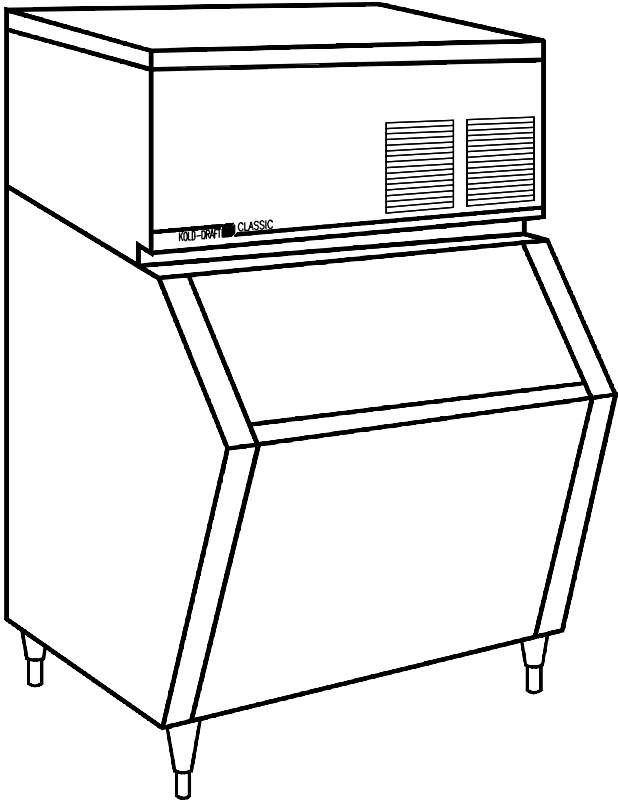

KOLD-DRAFT

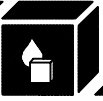

Ice Machine Products

an Ali Group Company



A Tradition of Excellence In Ice Equipment.

The Spirit of Excellence

Table of Contents, 3/02

	Page No.
Table of Contents, <i>CLASSIC</i> Models, 5/03 printing	1
Key to <i>CLASSIC</i> Cuber Model Numbers	2
<i>CLASSIC</i> Cuber Installation Specifications	3
<i>CLASSIC</i> Cuber Installation Guidelines	5
General Information	11
Preventive Maintenance	12
GB & GT <i>CLASSIC</i> Cuber Installation Instructions	14
<i>CLASSIC</i> Cuber Start-up Instructions	19
Chart of Refrigerant Operating Pressures, Ice Cube Sizes and Weights	20
GB Multiplexing (Stacking) Instructions	21
GT3XX Multiplexing (Stacking) Instructions	25
Operational Components, <i>CLASSIC</i> Cubers	32
Controls and Adjustments, <i>CLASSIC</i> Cubers	37
Sequence of Operation, <i>CLASSIC</i> Cubers	42
Service and Troubleshooting, <i>CLASSIC</i> Cubers:	
Actuator Motor	46
Water Plate	57
Liquid Level Controller	59
Cube Quality	60
Compressor Charts, <i>CLASSIC</i> Cubers	62
Wiring Diagrams, <i>CLASSIC</i> Cuber (Jan. '92 through Feb. '96)	68
Wiring Diagrams, <i>CLASSIC</i> Cuber (March '96 through Sept. '97)	77
Wiring Diagrams, <i>CLASSIC</i> Cuber (Oct. '97 and later)	81
T-25X/T-26X Crusher Installation Instructions	95
T-25X/T-26X Crusher Installation Specifications	99
T-25X/T-26X Crusher Preventative Maintenance	1 0 0
AKD-125 Dispenser Installation Instructions	1 0 1
AKD-125 Dispenser Installation Specifications	1 0 4
AKD-125 Dispenser Preventative Maintenance	1 0 5
Wiring Diagrams, T-250/T-251	106
Wiring Diagrams, AKD-125	107
Parts List-Pictorial, <i>CLASSIC</i> Cubers	108
Parts List-Pictorial, T-25X/T-26X/AKD-125	139
Parts List-Numerical, <i>CLASSIC</i> Models	140
Date Code	150

Key to Model Numbers

GB 4 5 1 W HK

Cube Size

C = Full Cube (1-1/4" 1-1/4" x 1-1/4")
HK = Half Cube (1-1/4" x 1/1/4" x 5/8")
K = Cubelet (5/8" x 5/8" x 1-1/4")

Condenser Type

A = Air Cooled Condenser-Self Contained
W = Liquid Cooled Condenser-Self Contained
R = For Remote Air Cooled Condenser

Electrical Characteristics

1 = 115 Volt-60 Hz.-1 Ph. (2-wire plus Ground)
4 = 208/230 Volt-60 Hz.-1 Ph. (2-wire plus Ground)
5 = 208/230 Volt-60 Hz.-3 Ph. (3-wire plus Ground)
7 = 220/240 Volt-50 Hz.-1 Ph. (2-wire plus Ground)

Modification Code

2 = R-502, Copeland Compressor except GB1224/GB1225 (Bristol)
3 = R-502, Bristol Compressor
4 = R-404a, Bristol Inertia Compressor/Polyolester Lubricant except
GT341/GT344 (Bristol Reed Valve Compressor w/POE Lubricant)
5 = R-404a, Tecumseh Compressor w/POE Lubricant

Classic Cuber Series

3 = 300 Series
4 = 400 Series
5 = 500 Series
6 = 600 Series
12 = 1200 Series

Cabinet Width

GB = Horizontal Unit (42" wide)
GT3XX = Slimline Unit (28-1/2" wide)
GT5XX = Slimline Unit (30" wide)

Installation Specifications

GB Series Cubers

MODEL	ELECTRICAL SUPPLY	MINIMUM CIRCUIT AMPACITY	FUSE/HACR BREAKER SIZE (AMPS)	
			NORMAL	MAXIMUM
GB431A	115/60/1	23.3	25	35
GB431W	115/60/1	20.1	25	30
GB431R	115/60/1	25	25	40
GB434A	208-230/60/1	12.7	15	20
GB434W	208-230/60/1	9.6	15	15
GB441A	115/60/1	21	25	30
GB441W	115/60/1	17.8	20	30
GB441R	115/60/1	17.8	20	30
GB444A	208-230/60/1	11.1	15	15
GB444W	208-230/60/1	10.2	15	15
GB451A	115/60/1	19.9	20	30
GB451W	115/60/1	16.4	20	25
GB454A	208-230/60/1	11.9	15	20
GB454W	208-230/60/1	11.3	15	15
GB454R	208-230/60/1	10.1	15	15
GB634A	208-230/60/1	16.6	20	25
GB634W	208-230/60/1	15.7	20	25
GB634R	208-230/60/1	14.8	15	25
GB644A	208-230/60/1	16.2	20	25
GB644W	208-230/60/1	15.3	20	25
GB644R	208-230/60/1	15.3	20	25
GB654A	208-230/60/1	18	20	30
GB654W	208-230/60/1	17.3	20	30
GB654R	208-230/60/1	17.4	20	30
GB1224W	208-230/60/1	28.2	30	45
GB1224R	208-230/60/1	28.2	30	45
GB1225W	208-230/60/3	18.8	20	30
GB1244W	208-230/60/1	29.1	30	50
GB1244R	208-230/60/1	29.1	30	50
GB1245W	208-230/60/3	15.5	20	25
GB1245R	208-230/60/3	15.5	20	25
GB1254W	208-230/60/1	32	35	55
GB1254R	208-230/60/1	32	35	55
GB1255W	208-230/60/3	16.9	20	25
GB1255R	208-230/60/3	17.6	20	25
GB1254A	208-230/60/1	34	35	55

Installation Specifications

GT Series Cubers

MODEL	ELECTRICAL SUPPLY	MINIMUM CIRCUIT AMPACITY	FUSE/HACR BREAKER SIZE (AMPS)	
			NORMAL	MAXIMUM
GT331A	115/60/1	17.8	20	25
GT331W	115/60/1	16.6	20	25
GT334W	208-230/60/1	8.6	15	15
GT341A	115/60/1	17.8	20	25
GT341W	115/60/1	16.6	20	25
GT344A	208-230/60/1	8.6	15	15
GT344W	208-230/60/1	8.6	15	15
GT351A	115/60/1	15.6	20	25
GT351W	115/60/1	14.4	15	20
GT354A	208-230/60/1	9.3	15	15
GT354W	208-230/60/1	8.6	15	15
GT551A	115/60/1	23.4	25	35
GT551W	115/60/1	17.9	20	30
GT551R	115/60/1	20	20	35
GT554A	208-230/60/1	14.9	15	25
GT554W	208-230/60/1	14.3	15	20

Voltage Tolerances

Nominal	No-load MAXIMUM	Full-load MINIMUM
115	126	104
208/230	252	198
220/240	250	210

Installation Guidelines

Kold-Draft® Remote Condenser Single Evaporator Cuber Charging Requirements

R-502, Factory charge is 96 oz. (6 lbs.)

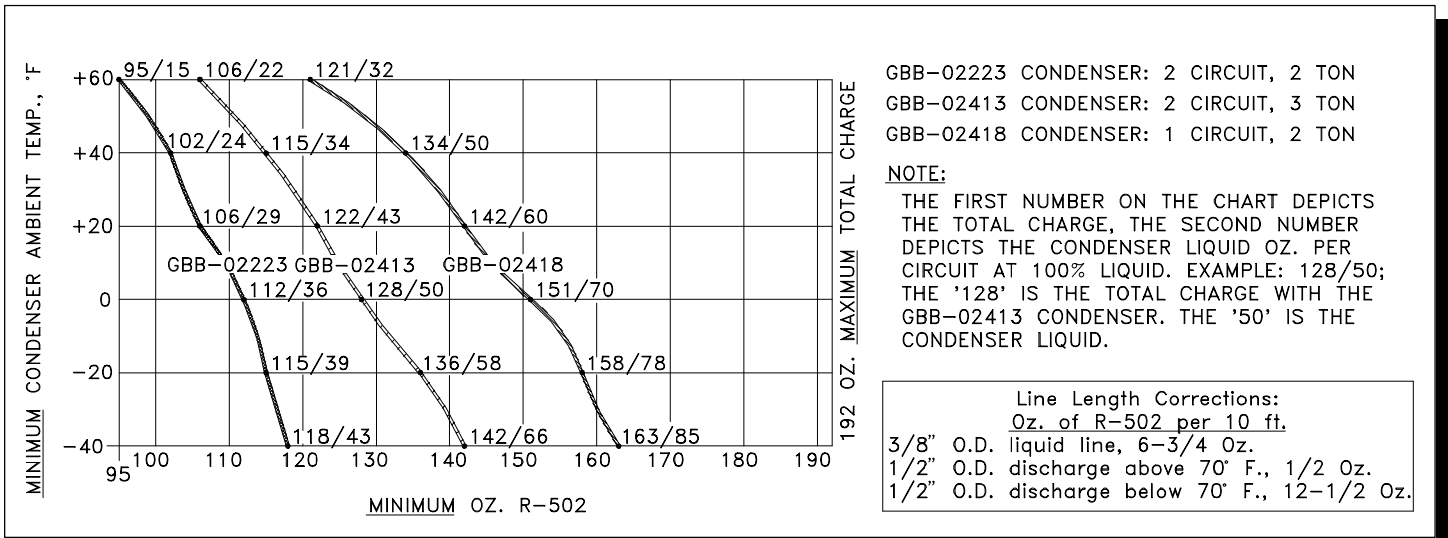

R-404a, Factory charge is 84 oz. (5.25 lbs.)

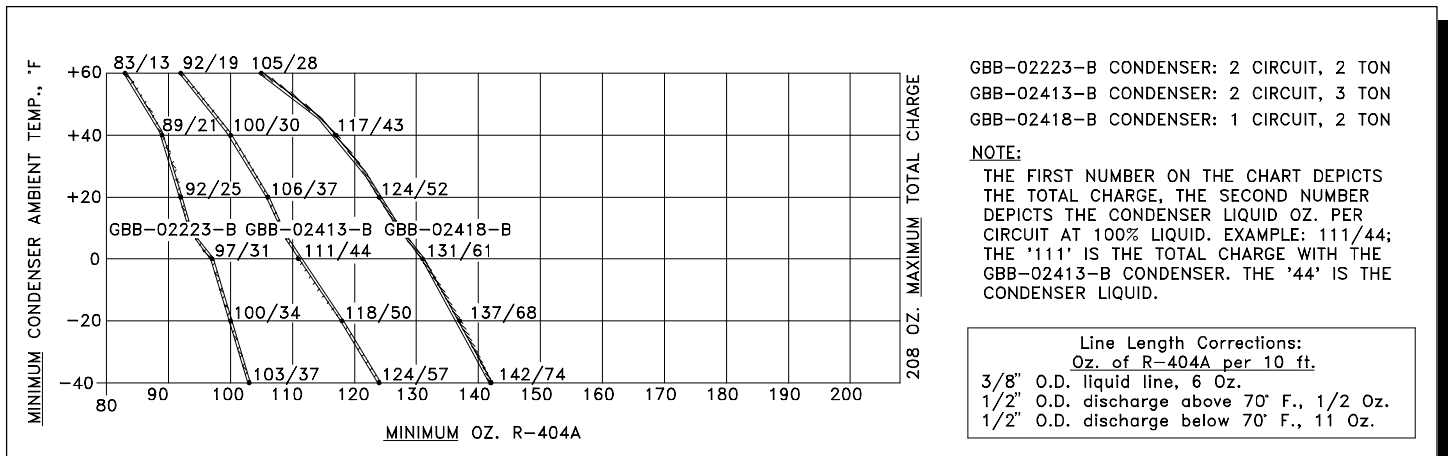

◆Charts based on 30 ft. of 1/2" O.D. discharge (15 ft. exposed to ambient temperature under 70° F.) and 30 ft. of 3/8" O.D. liquid return lines, at 20° F., T.D.

◆Lines over 50 ft. are not recommended.

◆Minimum Condenser Height: Condenser must be installed above refrigerant line quick connects at rear of ice machine. No part of the refrigerant lines, between the cuber and the condenser, should fall below this point.

SEE SEPARATE INSTRUCTIONS FOR THE CONDENSER.

◆For Condensers other than Kold-Draft®, the installer must determine the condenser liquid volume at minimum operating temperature.

➤For R-502 Cubers, the basic charge is 2 lbs. To this, add the condenser liquid volume calculation and the line charge calculation from the Line Length Correction Chart to obtain the minimum total charge.

➤For R-404a Cubers, the basic charge is 1-3/4 lbs. To this add the condenser liquid volume calculation and the line charge calculation from the Line Length Correction Chart to obtain the minimum total charge.

Installation Guidelines

Kold-Draft® Remote Condenser Dual Evaporator Cuber Charging Requirements

R-502, Factory charge is 128 oz. (8 lbs.)

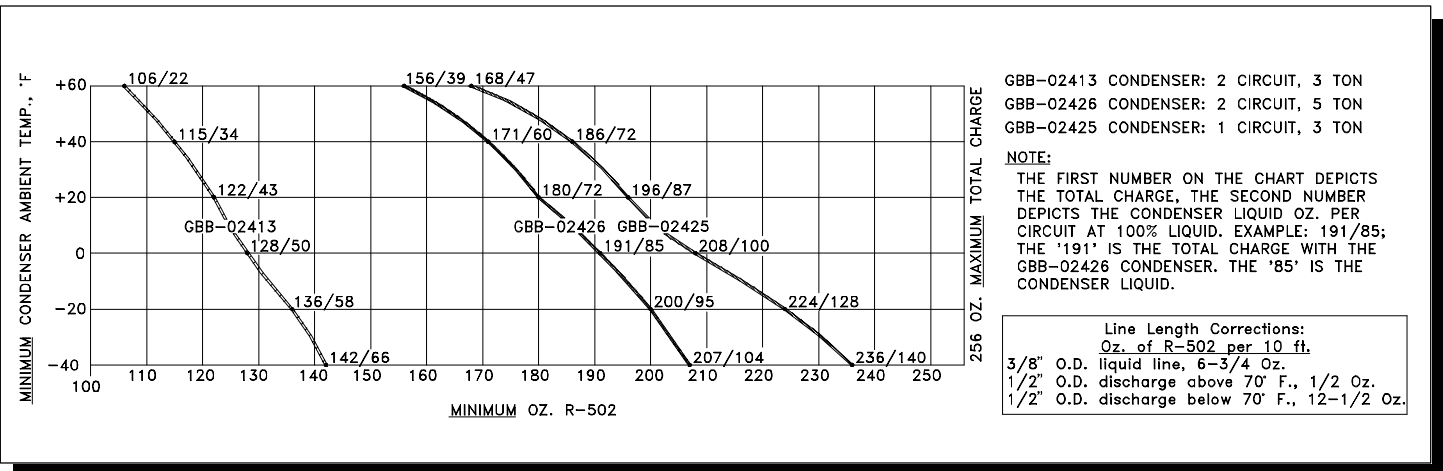

R-404a, Factory charge is 112 oz. (7 lbs.)

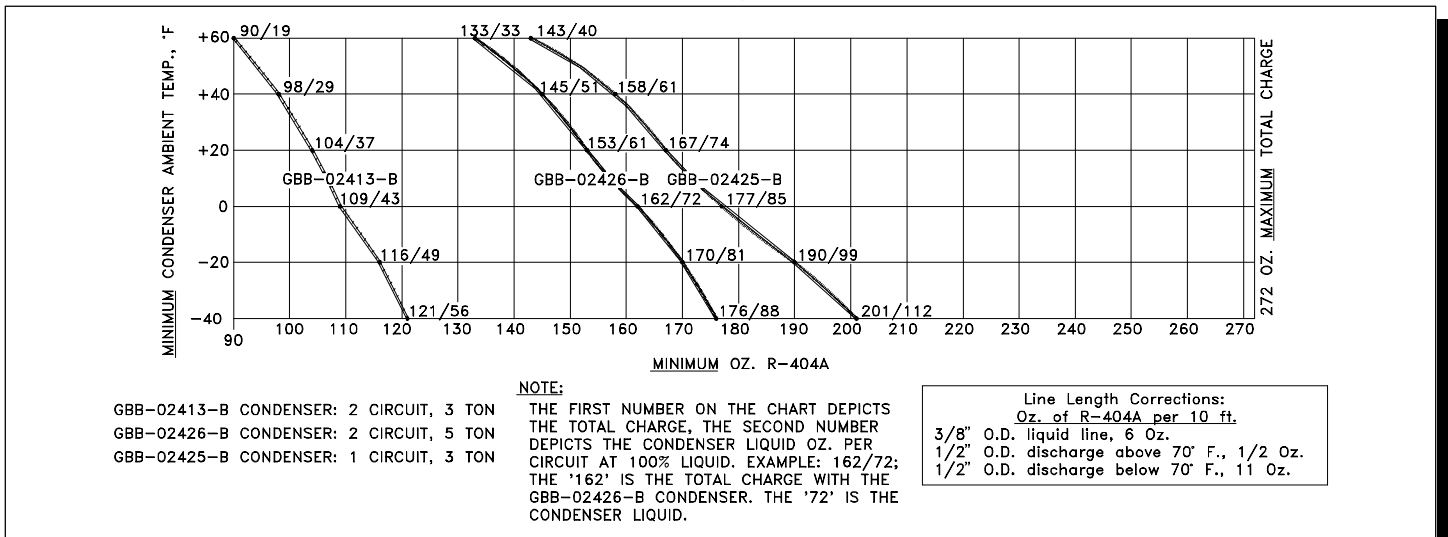

◆Charts based on 30 ft. of 1/2" O.D. discharge (15 ft. exposed to ambient temperature under 70° F.) and 30 ft. of 3/8" O.D. liquid return lines, at 20° F., T.D.

◆Lines over 50 ft. are not recommended.

◆Minimum Condenser Height: Condenser must be installed above refrigerant line quick connects at rear of ice machine. No part of the refrigerant lines, between the cuber and the condenser, should fall below this point.

SEE SEPARATE INSTRUCTIONS FOR THE CONDENSER.

◆For Condensers other than Kold-Draft®, the installer must determine the condenser liquid volume at minimum operating temperature.

➤For R-502 Cubers, the basic charge is 3-1/2 lbs. To this, add the condenser liquid volume calculation and the line charge calculation from the Line Length Correction Chart for the total charge.

➤For R-404a Cubers, the basic charge is 3 lbs. To this, add the condenser liquid volume calculation and the line charge calculation from the Line Length Correction Chart to obtain the minimum total charge.

Installation Guidelines

GB Cubers

PARAMETER	MODEL SERIES/CUBE SIZE					
	GB4XX		GB6XX		GB12XX	
	K	C/HK	K	C/HK	K	C/HK
Water fill level (Top of tank to level in control tube)	3-5/8"	2-3/4"	3-5/8"	2-3/4"	3-5/8"	2-3/4"
*Approximate cycle time, min.	15	33/26	13	25.5/21	12	22.5/18
Approximate harvest weight, lb.	4.0	7.7/7.1	4.0	7.7/7.1	8.0	15.4/14.2

REFRIGERANT CHARGE, Oz. (R-502)	MODEL SERIES					
	GB43X		GB63X		GB122X	
	Air cooled: 25		Air cooled: 35		-----	
	Liq. cooled: 22		Liq. cooled: 22		Liq. cooled: 60	
	Remote(MAX):192		Remote(MAX):192		Remote(MAX):256	

REFRIGERANT CHARGE, Oz. (R-404a)	MODEL SERIES					
	GB44X	GB45X	GB64X GB65X	GB124X GB125X		
	Air cooled:	22	19	28	62	
	Liq. cooled:	20	20	22	52	
	Remote(MAX):	208	208	208	272	

GT Cubers

PARAMETER	MODEL SERIES/CUBE SIZE				
	GT3XX		GT55X		
	K	C/HK	K	C/HK	
Water fill level (Top of tank to level in control tube)	3"	2-5/8"	3-5/8"	2-3/4"	
*Approximate cycle time, min.	14	31/21	15.5	31/24	
Approximate harvest weight, lb.	2.0	3.9/3.5	4.0	7.7/7.1	

REFRIGERANT CHARGE, Oz. (R-502)	MODEL/SERIES				
	GT33X				
	Air cooled: 27				
	Liq. cooled: 22				

REFRIGERANT CHARGE, Oz. (R-404a)	MODEL SERIES				
	GT34X	GT35X	GT55X		
	Air cooled: 24	Air cooled: 19	Air cooled: 30		
	Liq. cooled: 20	Liq. cooled: 20	Liq. cooled: 20		
	-----	-----	Remote(MAX):208		

* Values are for Air-cooled (or GB12XXW) models at 90° F. air/70° F. water temperatures with cuber adjusted to produce fully-formed ice. Greater capacity and energy efficiency can be obtained by reducing water fill level (lowering the high-level

Installation Guidelines

probe) to produce ice with larger dimples. A slight adjustment of the probe will result in a noticeable effect on dimple size. The control stream will not rise over the dam with lower water fill levels than indicated above.

All Liquid Cooled Models

The recommended condensing temperature is 104° F.(40° C.). If necessary to adjust the coolant regulator valve, the high side pressure at mid-freeze cycle should be 230 psig for R-502 or 250 psig for R-404a.

All Remote Air Cooled Models

Fan cycling controls are not provided and are not beneficial except to automatically stop the fan during off-cycles. If such controls are used the settings should not allow fan cycling during freeze cycles. The suggested settings for fan cycling controls are: ON at approx. 250 psig; OFF at approx. 220 psig

CAUTION: Fan cycling controls do not reduce the minimum charge requirements. If there is not an adequate amount of liquid refrigerant in the receiver at start-up, the system will pump down repeatedly or run at a very high superheat (low back-pressure) with little -or- no refrigeration at the evaporator(s). Refer to the Remote Condenser Model Charging Requirements section.

CAUTION:

- ◆ RISK OF PROPERTY DAMAGE, EQUIPMENT FAILURE, OR FIRE.
- ◆ Failure to comply with all installation specifications and instructions may cause erratic operation and the risk of damage or fire.

Ambient Operating Temperatures

Minimum: 45° F. (7° C.) **NOTE:** Under 60° F may cause erratic bin thermostat operation
Maximum: 90° F. (32° C.)

Potable Water and Condensing Liquid Supply

Minimum Water Temperature: 45° F. (7° C.)
Maximum Water Temperature: 90° F. (32° C.)
Minimum Water Pressure: 30 psig
Maximum Water Pressure: 100 psig*

* If regulator is used, recommended setting is 30 to 50 psig

Clearance Requirements

GB Cubers (except GB1250A---see the following drawings)

REAR (beyond condenser if protruding from cabinet) and **TOP:** 6 inches

RIGHT SIDE: 8 inches

LEFT SIDE: 4 inches

	GT 3XX Cubers	GT55X Cubers
REAR and TOP:	6 inches	8 inches
RIGHT SIDE:	6 inches	4 inches
LEFT SIDE:	6 inches	4 inches

Installation Guidelines

Plumbing Requirements

Potable Water Inlet Fitting: 1/4" F.P.T. (GB430/GB440/GB450/GB630/GB640/GB650)
 1/2" F.P.T. (GB1220/GB1240/GB1250)
 1/4" F.P.T. (GT330/GT340/GT350/GT550)

Drain: 3/4" I.D. flexible tubing

Liquid Cooled Condenser Inlet Fitting: 3/8" F.P.T.

Liquid Cooled Condenser Outlet Fitting: 1/2" F.P.T.

Remote Air Cooled Liquid Line Fitting: 3/8" Tubing Quick Connect

Remote Air Cooled Discharge Line Fitting: 1/2" Tubing Quick Connect

Electrical, water and drain locations are shown on the following (5) drawings:

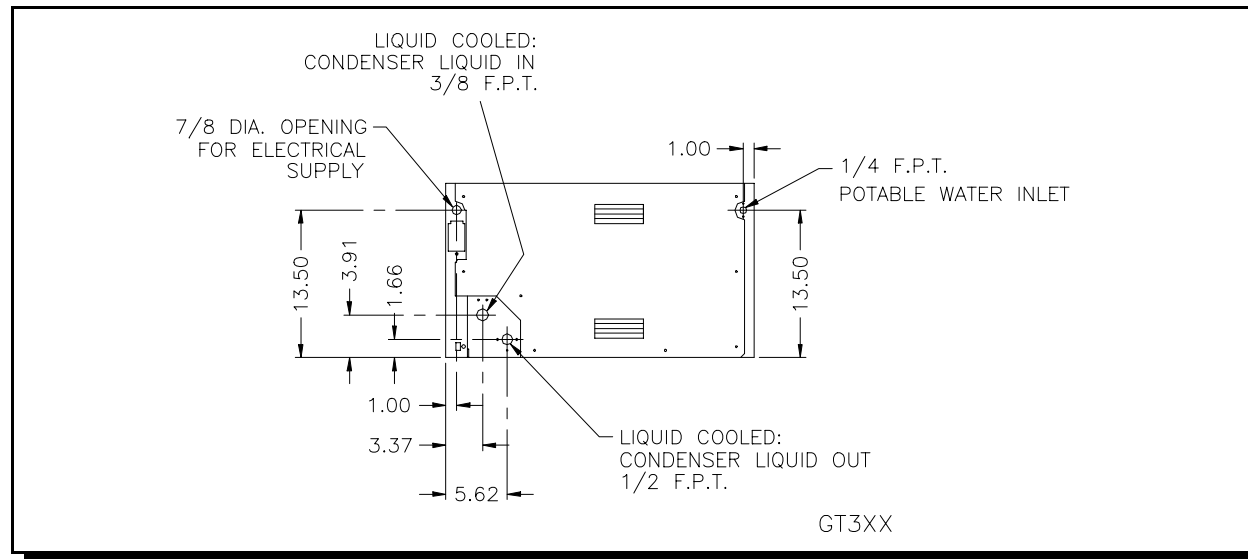
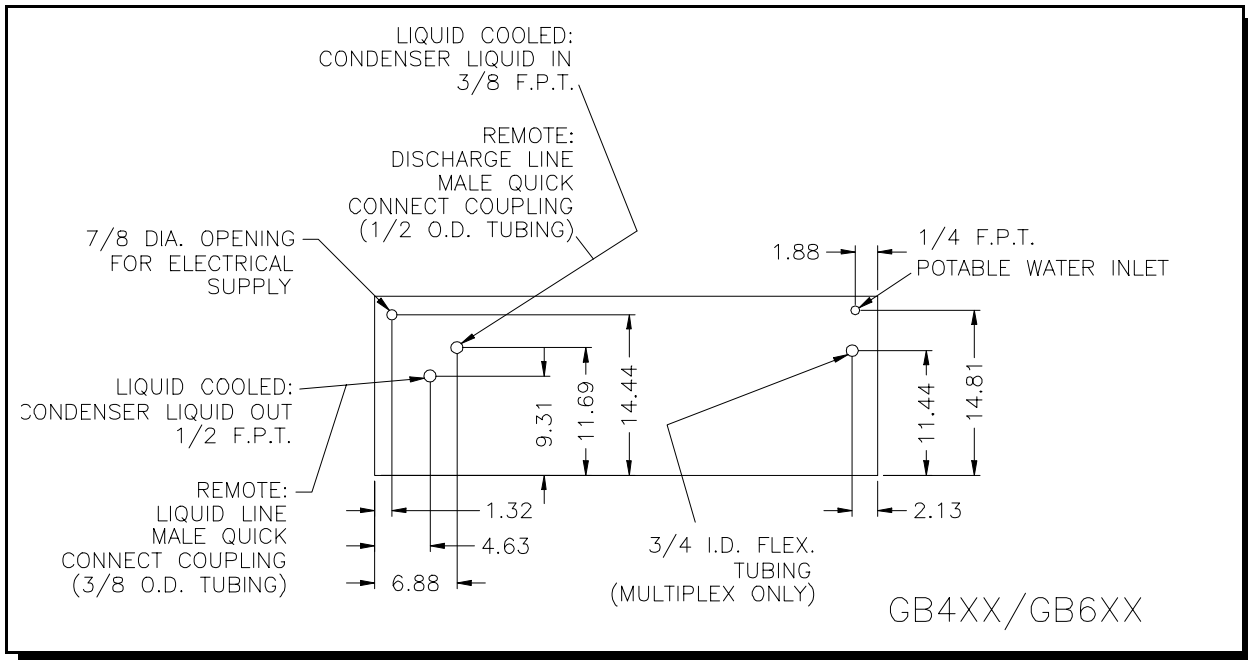

Installation Guidelines

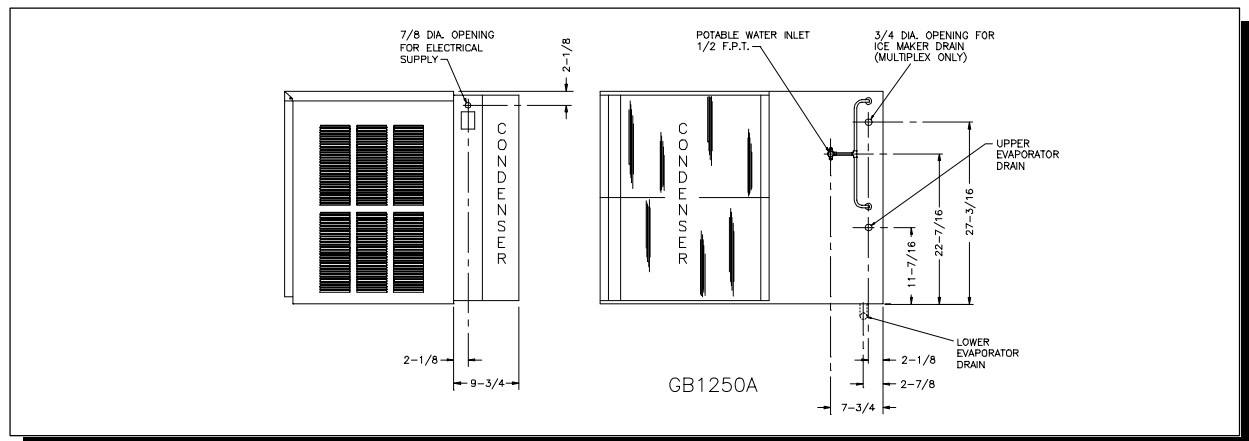
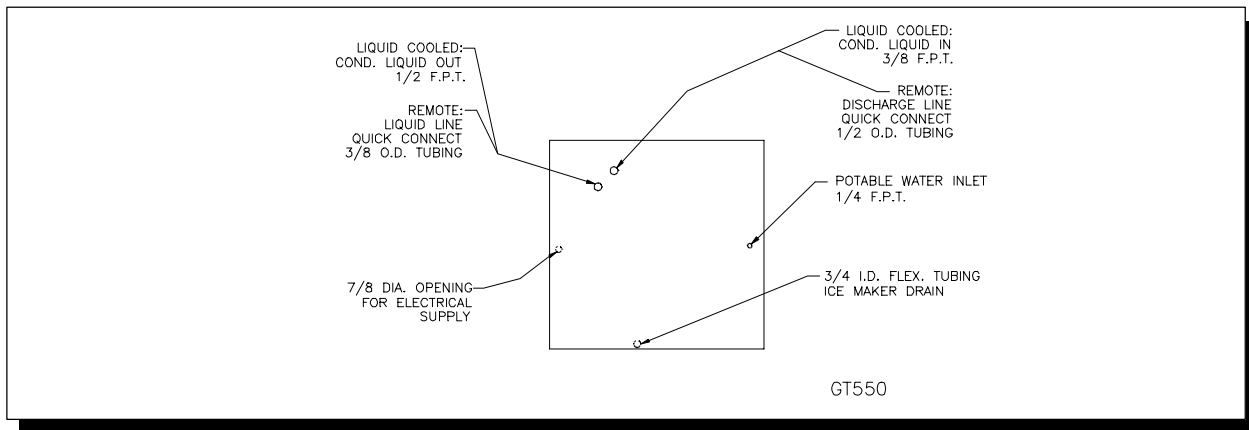
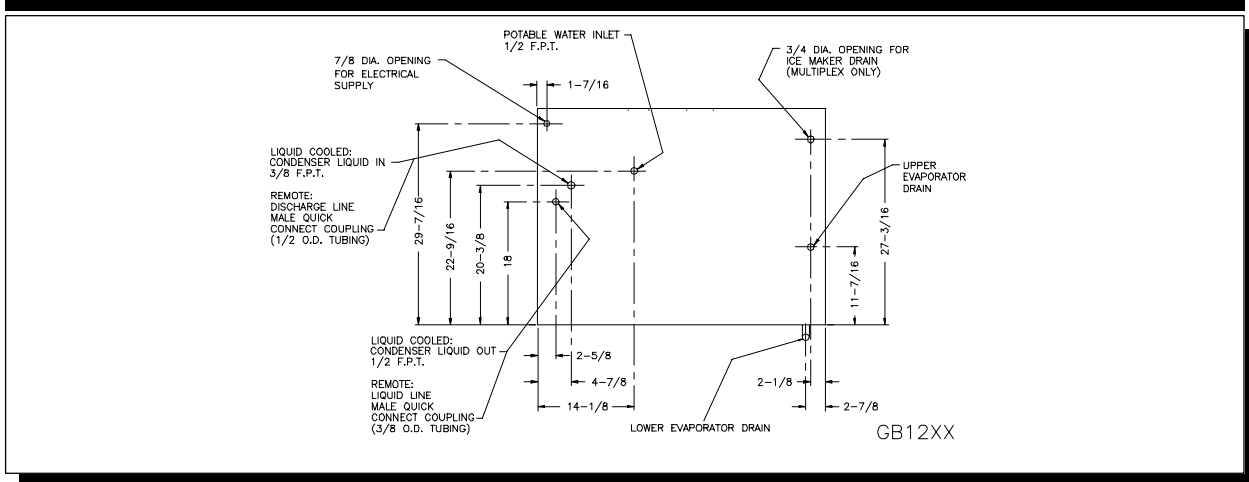

Water Treatment

There are no specific requirements for water treatment provided that the ice making supply water is potable and not laden with sediment. **The use of additional water treatment may facilitate or reduce the frequency of the need for cleaning as well as reduce the corrosive effects of chlorinated (greater than 0.2 ppm residual chlorine) water supplies.**

Please consult your local water conditioning supplier for specific recommendations.

General Information

CAUTION:

- ◆ RISK OF PROPERTY DAMAGE, EQUIPMENT FAILURE OR FIRE.
- ◆ Failure to comply with all installation specifications and instructions may cause erratic operation and the risk of damage or fire.

Ampacity: Minimum ampacity does not indicate typical running current value. Refer to equipment NAME PLATE data. Use minimum ampacity value for sizing branch circuit conductors up to 25 feet in length. For conductor length over 25 feet up to 100 feet, increase 1 AWG size. Over 100 feet requires a 2 or more AWG size increase.

Branch circuit protection: Proper protection must be provided by either fuse(s) or HACR type circuit breaker(s). Each ice maker must be provided with a separately protected circuit with no other load(s). A fused disconnect installed adjacent to each ice maker is recommended (must be supplied by installer), and may be required by local codes. NORMAL protector size is based on rated voltage and operation at lower than extreme temperature limits. When branch circuit conductors are sized to permit, increasing the protector size (up to the specified maximum) may avoid nuisance protector opening under harsh operating conditions.

Water supply: Minimum 30 psig supply pressure while the ice maker is filling is required. The water fill rate is 0.6 GPM for each GT330, GT340, or GT350, 1 GPM for each GB430, GB440, GB450, GB630, GB640, GB650, or GT550, and 2 GPM for each GB1220, GB1240, or GB1250. Backflow/Backsiphonage protection is provided by an internal air gap (accepted by NSF). If additional protection is required by local codes or authorities, any device(s) and installation of the same, including specification and cost, are the responsibility of the installation specifier.

Ice maker drain: The size of the gravity drain for the ice maker purge and rinse water must not be reduced. Individual drains from stacked ice makers may be discharged into a standpipe or manifold with a minimum 1-1/2 inch air gap at each ice maker connection.

Liquid condenser coolant pressure drop: Condenser coolant pressure drop may reach 20 psig during peak load with 85° F. coolant temperature at recommended refrigerant high-side pressure. The condenser coolant (water) regulating valve may require adjustment due to variations in the coolant supply characteristics to provide optimum efficiency.

Remote condenser models: Remote condenser models from the factory carry a minimal charge and will likely require an additional refrigerant charge to accommodate all condenser ambient temperatures and/or the volume potentially contained in refrigerant lines and condensers. There is a label on the receiver that indicates factory charge and the maximum charge, along with a space to write in the total system charge. Ice makers are provided with re-sealable refrigerant line connection couplings. For **all** remote condenser installations refer to the **Installation Guidelines** located in the front of this manual.

All models are intended FOR INDOOR USE ONLY with PERMANENT CONNECTION TO THE FIELD ELECTRICAL SUPPLY. The remotely-installed condensers supplied by **Kold-Draft®** may be installed outdoors, and they require a separate electrical supply.

Preventative Maintenance

Cleaning: Usually at 3 to 6 months intervals, depending on water conditions.

Inspections: During cleaning - at least twice a year.

Service: All such equipment will require service at some time. Service requirements will be minimized with faithful preventative maintenance including good housekeeping at the installation site. A CALL FOR SERVICE AS SOON AS A POSSIBLE PROBLEM IS NOTICED MAY AVOID EXTENSIVE REPAIRS.

CAUTION:

- ◆ RISK OF PERSONAL INJURY OR PROPERTY DAMAGE.
- ◆ Do not use ammonia solutions in cleaning any part of the ice maker.
- ◆ Do not mix ice machine cleaner and sanitizer together.
- ◆ Use rubber gloves, eye protection and an apron.
- ◆ Clean up splashes or spillage immediately.
- ◆ Follow these instructions exactly.

Ice Cuber Cleaning Instructions

1. **GB & GT55X:** Mix one bag of **Kold-Draft**[®] ice machine cleaner (55R-01000) in (2) quarts, or **GT3XX:** Mix 1/2 bag of **Kold-Draft**[®] ice machine cleaner (55R-01000) in (1) quart of clean, warm water (180° F. MAX.) for each evaporator/water plate assembly to be cleaned.
2. If the cuber is operating, wait until a harvest cycle occurs then trip the 'ICE-OFF-WASH' switch to 'WASH' as soon as the water plate begins to close.
3. Empty all ice from the storage bin and shut off other ice makers on the same bin.
4. After the water fill is completed, switch the 'ICE-OFF-WASH' to 'OFF'. While pinching the water level control hose, carefully remove the water level control tube from the cap. **HOLD THE TUBE HIGH ENOUGH SO THAT THE TUBE DOES NOT OVERFLOW.** Release the hose and pour about half of the mixed cleaner into the tube. Replace the tube on the cap, while pinching the water level control hose, then pour the remaining cleaner into the control stream box.
5. Switch the 'ICE-OFF-WASH' to 'WASH' and allow the cleaner to circulate for approximately 15 minutes, then pull the right side of the water plate down until the pump stops and hold it until the pump will not re-start when released.
6. The water plate will open and dump the cleaner then close immediately, and the water system will refill. Repeat this dumping and refilling three (3) times to rinse out all of the cleaning solution.
7. Mix a sanitizing solution of two (2) oz. 5-1/4% sodium hypochlorite (household bleach or equivalent) and one (1) quart clean water.
8. As in step #4, pour about half of the sanitizing solution into the water level control tube and the remaining sanitizer into the control stream box.
9. Allow the sanitizing solution to circulate **AT LEAST 15 MINUTES**, then dump and rinse two (2) times as described above. If necessary, reset the water level probes to the proper levels.

Preventative Maintenance

10. While the cleaning and sanitizing solutions are circulating, clean, rinse and sanitize all accessible parts of the ice-making compartment of the cuber with clean cloths. Use a cleaning solution of 8 tablespoons (1/2 cup) baking soda per gallon of warm water, and a sanitizing solution of no less than 1 teaspoonful (5 ml.) 5-1/4% sodium hypochlorite per quart of clean water.
11. After cleaning has been completed, trip the 'ICE-OFF-WASH' switch to 'ICE' and check to be sure that the cuber is operating properly, particularly the water level probes. Then re-assemble and secure all cabinet enclosure panels.

Ice Bin Cleaning Instructions

The bin should be cleaned periodically. If bin drain has any horizontal run, remove ice from left side of bin and flush with two (2) quarts of hot water monthly. (Long drain lines should be flushed weekly.)

1. Clean exterior of bin frequently.
2. To clean the interior, follow the instructions provided with bin.
3. Empty the storage area and disconnect the electrical power supply to the ice maker(s).
4. Remove the ice maker inspection panel, top, left and right end panels, and drain pan. Sliding bin doors may be removed by lifting them up, then pulling out from the bottom.
5. When cleaning the ice maker, follow the ice maker cleaning instructions and clean the bin last.
6. Replace all enclosure panels and drain pan before re-connecting the electrical supply.

CAUTION:

- ◆ RISK OF PERSONAL INJURY, EQUIPMENT DAMAGE OR CONTAMINATION OF THE ICE BIN.
- ◆ Do not use ammonia solutions or strong detergents in cleaning any part of the ice maker or bin.
- ◆ Never use appliance polishes, finish preservatives or cleaners in ice storage areas.

Winter Conditioning

Ice cubers that are idle in the winter months require preparation to prevent damage from freezing. The following procedure should insure the safety of the cuber so that it can be started easily the following year.

1. Shut off and detach the water supply to the ice cuber.
2. If the cuber contains a water-cooled condenser, the cuber must be running while air is introduced through the condenser water inlet connection to blow the water out of the condenser coils.
3. The cuber should then be run into defrost to drain the water tank and air should be introduced into the water inlet to blow out the water solenoid.

GB & GT Cuber Installation Instructions

CHECK FOR FREIGHT DAMAGE BEFORE PROCEEDING. Even though damage to the carton may not have been evident, check for hidden damage and contact freight carrier immediately, if necessary, to file a claim.

THIS EQUIPMENT MUST BE INSTALLED IN COMPLIANCE WITH THE APPLICABLE FEDERAL, STATE/PROVINCE AND/OR LOCAL PLUMBING, ELECTRICAL AND HEALTH/SANITATION CODES AND REQUIREMENTS.

CAUTION:

- ◆ RISK OF PERSONAL INJURY, PROPERTY DAMAGE, EQUIPMENT FAILURE OR FIRE.
- ◆ Refer all maintenance to qualified personnel.
- ◆ Never operate this equipment with covers, panels or other parts removed or not properly secured.
- ◆ Warn all users to clean up spillage immediately, keep storage bin doors closed, and report any apparent leakage or unusual sounds to responsible maintenance personnel.

Installation

NOTE: For Multiplex Installations, please refer to Multiplex specific instructions before proceeding.

Clearance and Utility provisions are shown on the following (4) drawings:

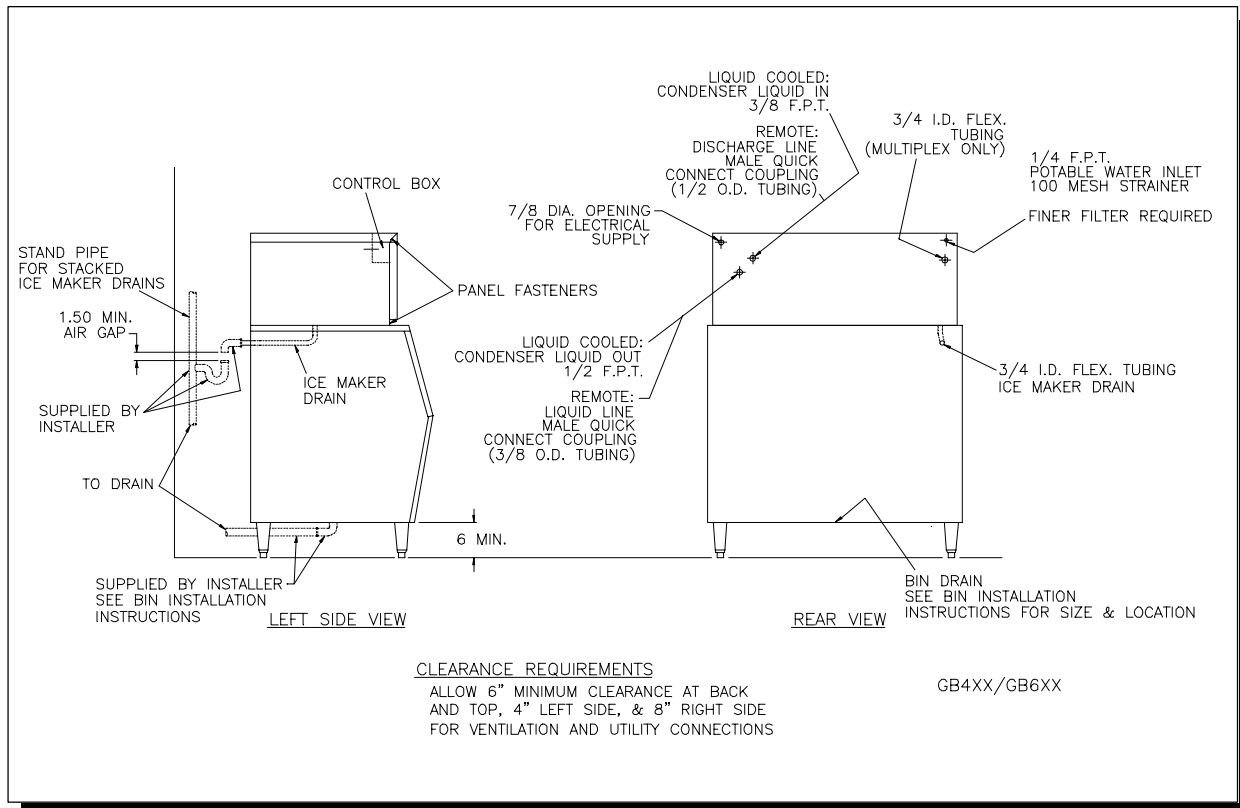

GB & GT Cuber Installation Instructions

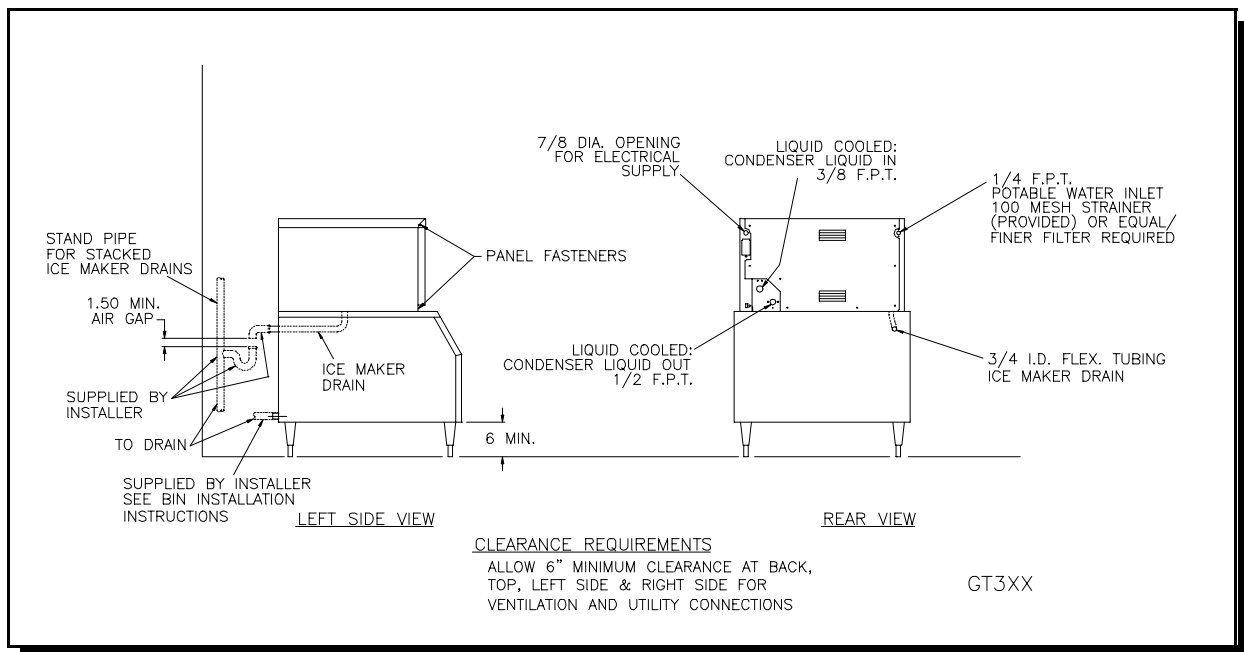
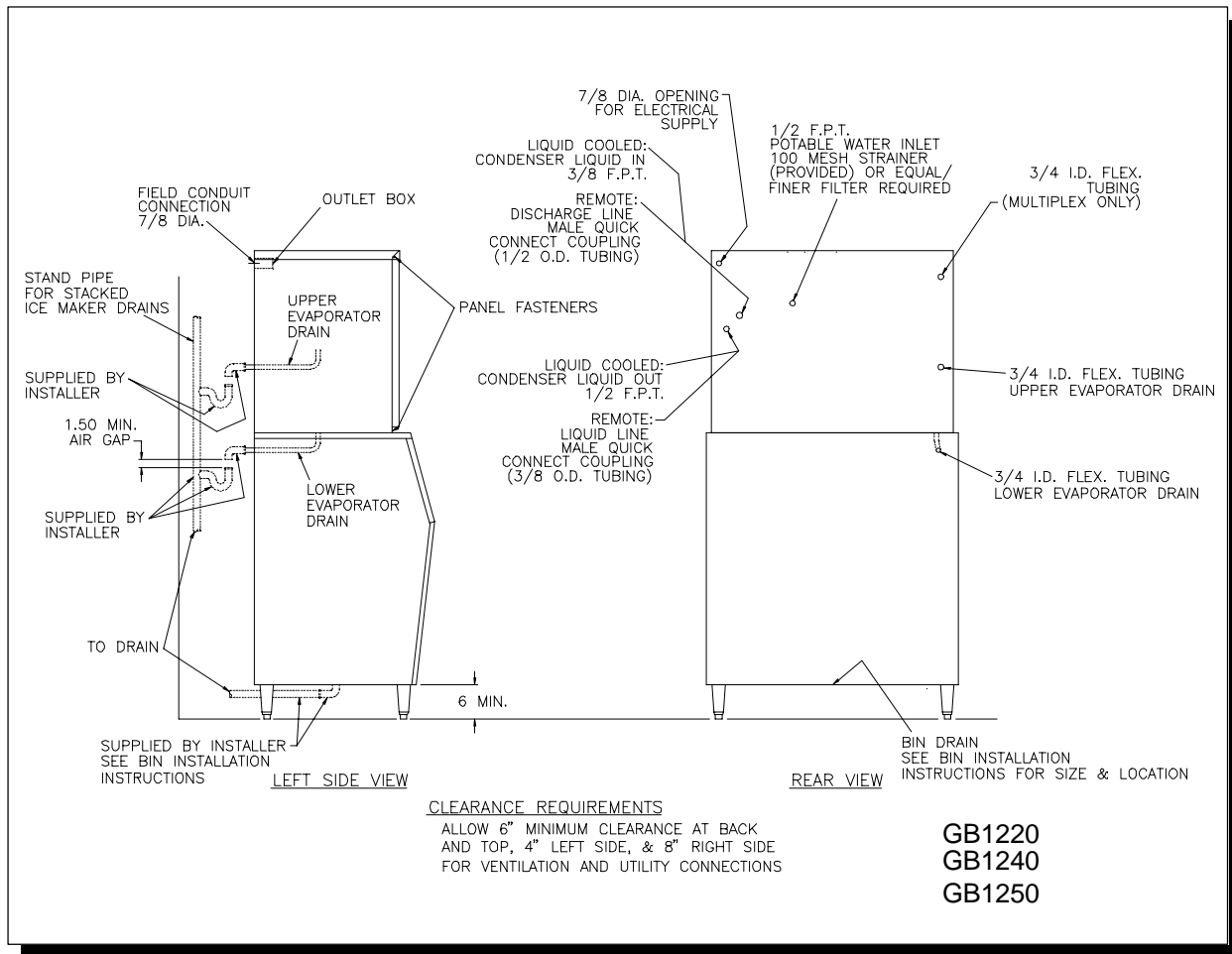

GB & GT Cuber Installation Instructions

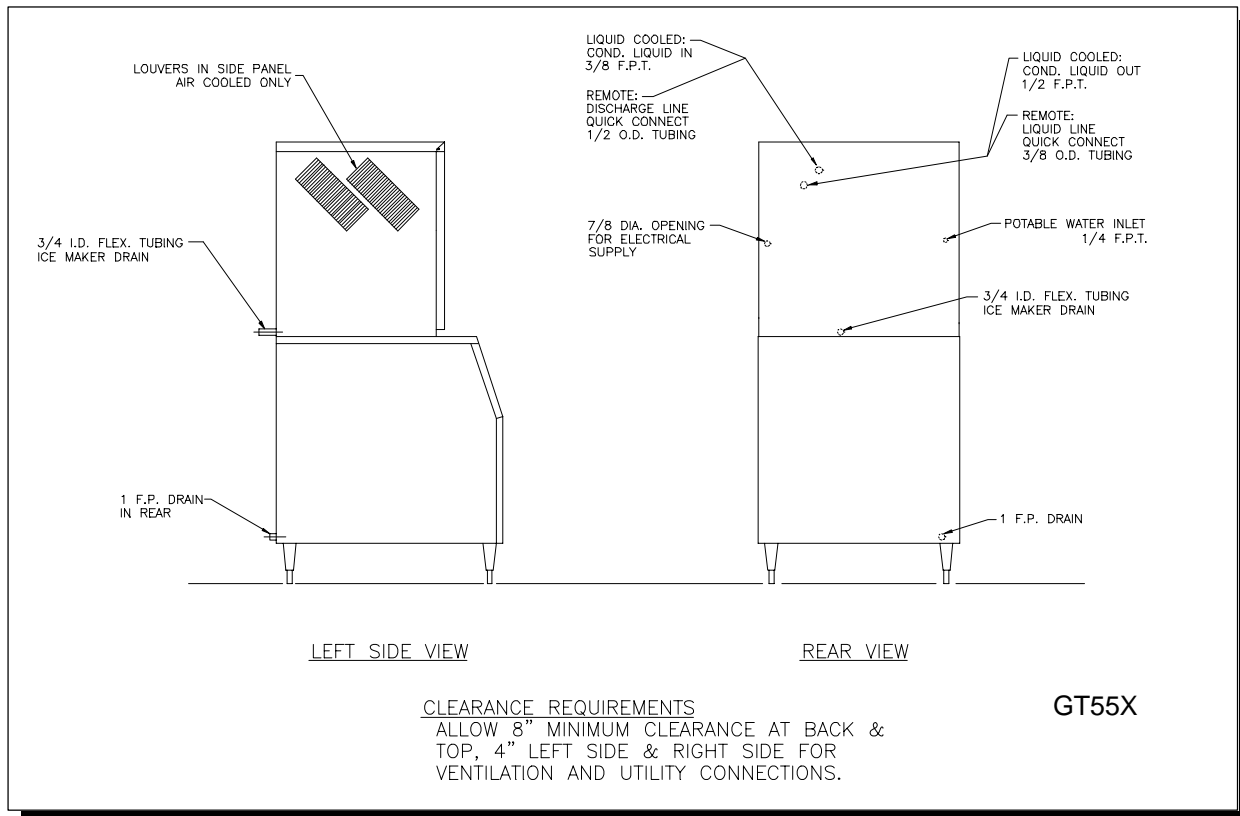

1. Position the ice storage bin so that minimum clearances will be available around the ice maker for ventilation and utility connections.
2. Level the bin with adjusters on legs, or by shimming if the bin is to be sealed to the floor. If gaps due to shims are greater than 1/8 inch, install a cove molding around the bin bottom. Seal the bin or molding to the floor with NSF Certified RTV sealant (Dow Corning RTV 732 or equal).
3. Remove the cuber cabinet TOP Panel as follows: Lift from the front and pull forward (**GT55X** push backward) until the rear clip is disengaged from the chassis..
4. Remove the remaining cuber cabinet panels as follows:
FRONT: Remove the (4) screws at the bottom and front-sides, pull forward.
SIDES: Pull forward and lift to disengage the clips from the chassis.
NOTE: When re-installing the panels, make sure that the screws engage the TOP panel.
5. **GB:** Remove the ice deflector(s), ice chute(s) and drain pan(s). The Drain tube assembly(s) is(are) packed with the drain pan(s).
GT3XX: Remove the ice chute/drain pan. The drain tube is packed with the drain pan.
GT55X: Remove the ice chute and drain pan. The drain tube is packed with the drain pan.

GB & GT Cuber Installation Instructions

6. Install gasketing on top of bin if required. Gasket material must be positioned so that it extends to the outside edge of the perimeter of the cuber chassis when the cuber is in place.
7. **CAREFULLY** place the cuber onto the gasketed bin, noting the alignment of the mounting holes in the chassis if mounting means are provided on the bin. Follow the bin installation instructions for securing the cuber to the bin.
8. **GB:** Install the drain pan(s), ice chute(s) and ice deflector(s). Route the drain tube assembly(s) through the rear of the bin, and clamp the tubing to the drain pan nipple(s).
GT3XX: Install the drain pan/chute. Route the drain tube through the rear of the bin, and clamp the tubing to the drain pan nipple.
GT55X: Install the drain pan. Route the drain tube through the rear of the cuber, and clamp the tubing to the drain pan nipple.

WARNING:

- ◆ RISK OF CONTAMINATION OF ICE IN THE BIN.
- ◆ Provide separate, unconnected drains for the ice maker and the bin.
- ◆ Consult local codes for suitable connections to the building drains.

9. Purge the potable water supply line.
10. Remove the water plate shipping strap(s).
11. **GB:** Route the bin thermostat capillary tube through the grommet, in the condensing unit pan and push all the way down. (See the following diagrams) Note- It may be necessary to increase the distance that the cap tube enters the ice storage area. Bin geometry, deflectors, baffles, etc., may cause an ice jamb above the bin door opening. Carefully uncoil the insulated loop of cap tube, while recoiling it further up, to lower the bin fill level. **Caution: do not kink the cap tube. THIS SECTION IS AS REVISED SEPTEMBER, 2004.**

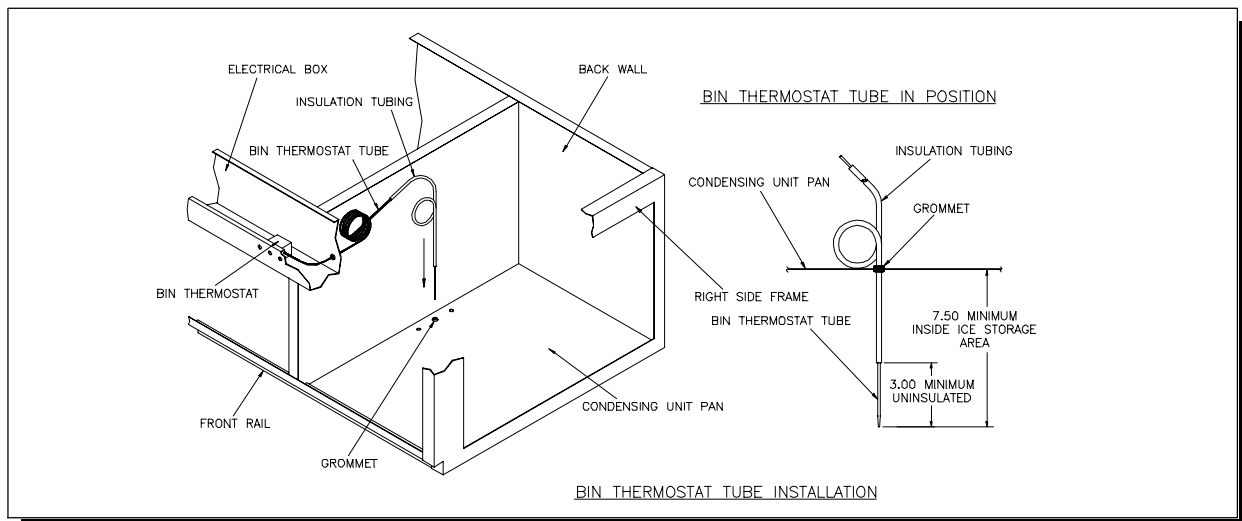

GB & GT Cuber Installation Instructions

GT3XX: Route the bin thermostat capillary tube through the grommet in the right end frame wall and under the ice chute. See the diagram and notes following for location and securing of the capillary tube.

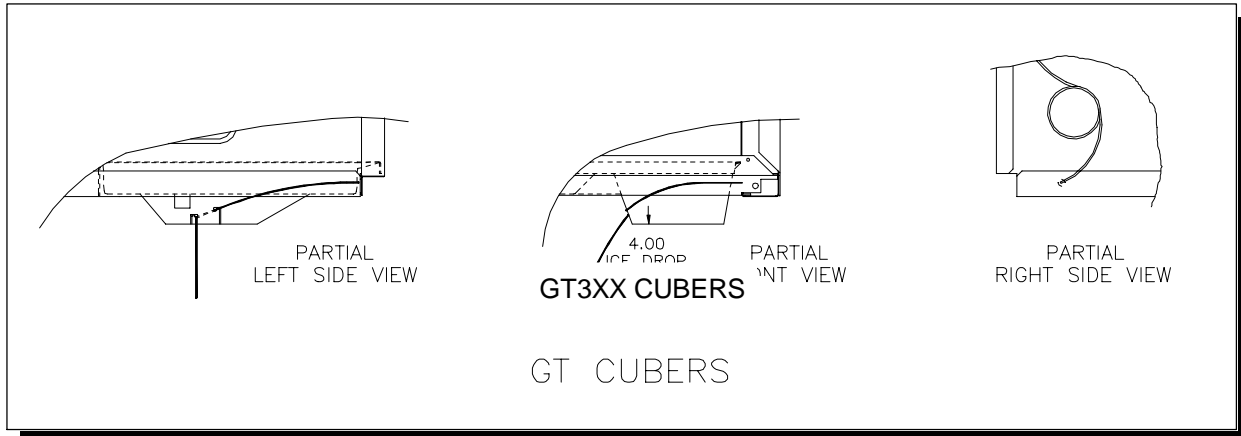

GT55X: Route the bin thermostat capillary tube along the right end frame wall and front rail, out through the bulb holder and down into the bin. See the diagram following for location and securing of the capillary tube.

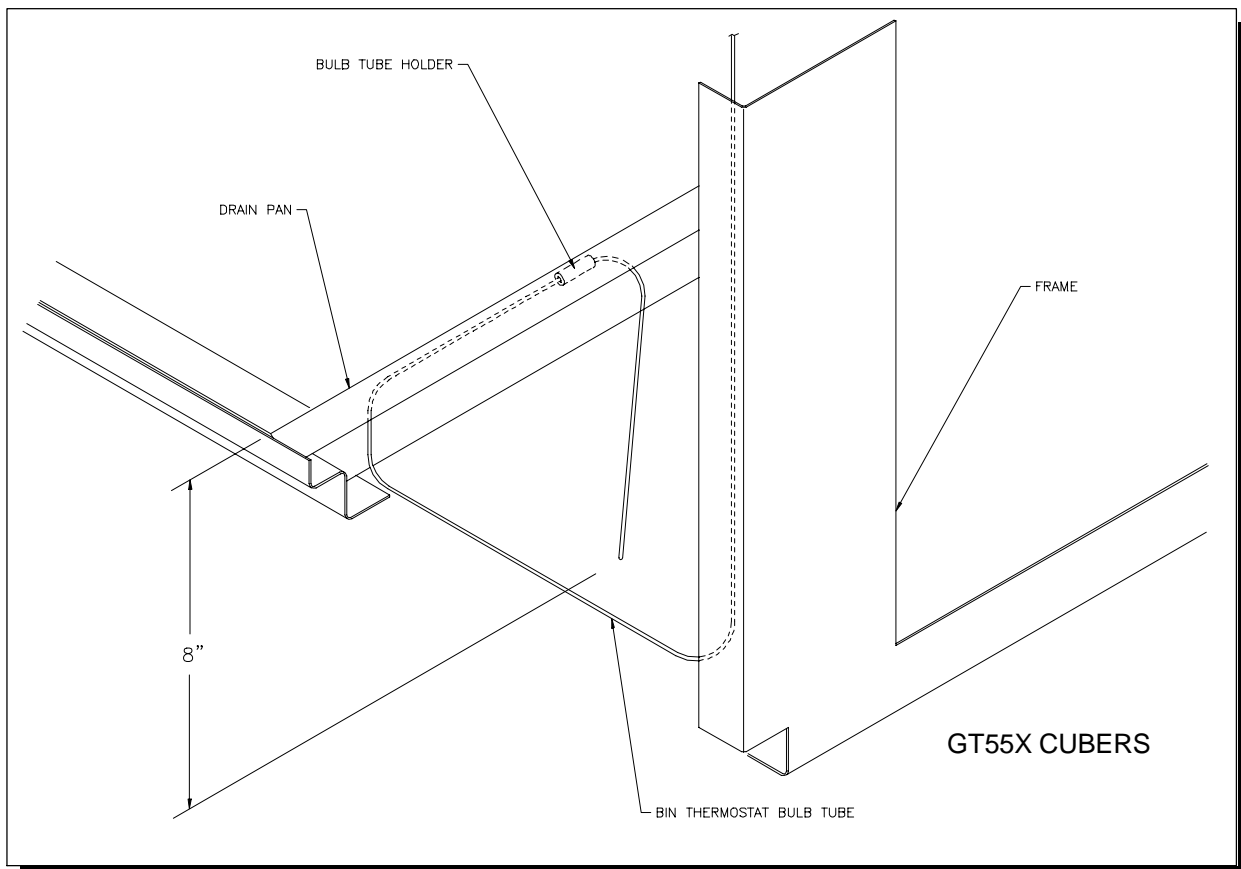

12. If start-up will not occur immediately, secure all cuber cabinet panels now.

INSTALLER NOTE: There is no electrical interconnection provision in "R" models for the condenser fan.

Cuber Start-up Instructions

Consult the **Installation Specifications**, **Sequence of Operation** and **Service and Troubleshooting** sections if variations from the following description of operation are noticed.

1. Remove the top and front cabinet panels.
2. Be sure that the 'ICE-OFF-WASH' switch is in the center 'OFF' position.
3. Install and connect refrigerant lines and condenser on "R" models.
4. Turn on supply water and power. Be sure that condenser liquid ("W" models) or refrigerant lines and condenser ("R" models) are ready for use before turning power on. Check for leaks in water/liquid supply connections. NOTE, "R" MODELS ONLY: The compressor will start immediately when power is applied, **regardless of the 'ICE-OFF-WASH' switch position**, if the low-side pressure is at or above the pump-down controller cut-in setting. Be sure that the compressor stops when the low-side pressure is between 5 and 10 psig.
5. Be sure that pump hoses are connected, then pour approximately one pint of clean tap water into the circulation system to lubricate the pump seal.
6. Move the 'ICE-OFF-WASH' switch to the right 'WASH' position and observe the water fill cycle and the pump running. If all water distributor holes do not produce full streams and the appearance of air is evident in the tube, pinch the plastic tube connected to the water solenoid valve outlet while water is running until the streams are full all the way across the distributor tube. Water fill is complete when the water in the liquid level control tube reaches the high-level probe. At this time, observe that the water shuts off and that there are no water leaks (dripping into the drain pan). **NOTE: In dual-evaporator models, be sure that the Master and Slave water fill level difference is less than 1/4" for "K" or 1/8" for "C" or HK" cube sizes.** See LIQUID LEVEL CONTROLLER text.
7. Pull the right end of the water plate down, stretching the springs until the pump stops, and hold until the pump does not re-start when released. The water plate will open fully to dump the batch of water previously taken in, then close immediately. The water plate should stop when it is fully closed, and the water fill cycle will repeat.
8. After the water fill is complete, move the 'ICE-OFF-WASH' switch to the left 'ICE' position and observe that the compressor (and fan in "A" models) starts, and the water pump continues to run. The refrigeration system operation should be checked during the first few cycles, and any adjustments should be made at this time. Consult the **"Controls and Adjustments"** section in this manual. Initial ice making cycles may exhibit super-cooling of the circulating water so that ice crystals form in the circulating water (slush), possibly stopping the flow momentarily. If water goes over the control stream dam when circulation resumes after two (2) cycles AND with all skin panels installed, consult the Factory.

Cuber Start-up Instructions

9. Test the bin thermostat(s) by holding some ice against the capillary tube(s). If necessary, adjust the thermostat(s) so that the ice maker(s) shut off within 30 seconds after ice contacts the capillary tube(s).
10. Be sure that the (**GB**: drain pan(s), ice chute(s) and deflector(s) are in place,) (**GT**: drain pan and ice chute is in place,) and that the electrical control box cover(s) is(are) secured, then replace the cabinet panels(skins). Start with the SIDE panels, then the FRONT panel. Secure the FRONT panel with (2) screws along the bottom edge, replace the TOP panel and finally secure all the panels with (2) screws in the TOP-SIDES of the machine.
11. Discard ice from start-up cycles, then clean and sanitize the bin following the instructions provided with the bin.
12. Complete and mail the Registration Certificate and leave all instructions with the owner/user. Emphasize the "**CAUTION: RISK OF PERSONAL INJURY...**" notice on the first page of the **GB & GT Cuber Installation Instructions**, and the importance of Preventative Maintenance.

CHART OF TYPICAL REFRIGERANT OPERATING PRESSURES

All pressures are in psig

TIME	LOW-SIDE, R-502 or R-404a	HIGH-SIDE					
		R-502			R-404a		
		W	A	R	W	A	R
Beginning of freeze cycle	Approx. 50	230*	**	180 Min. ****	250*	**	200 Min. ****
Just before harvest	12 to 20	230*	***	180 Min. ****	250*	***	200 Min. ****
Harvest cycle	70 to 150	Approx. 150	Approx. 150	150 Minimum	Approx. 150	Approx. 150	150 Minimum

All pressures may vary with operating conditions and adjustments.

- * 104° F condensing temperature--adjustable with coolant regulator valve.
- ** High-side pressure at beginning of freeze cycle in "A" models is likely to be higher than pressures shown for "W" models.
- *** High-side pressure just before harvest in "A" models in cool ambients is likely to be lower than pressures shown for "W" models.
- **** See remote condenser charging requirements if lower than minimum shown.

ICE CUBE SIZES AND WEIGHTS

CUBE SIZE LETTER	DIMENSIONS (Inches/cm)	Weights and Cubes per Batch			
		Weight, each cube (oz./g)	GT3XX	GB4XX, GB6XX, GT5XX	GB12XX
C	1.2 x 1.2 x 1.2/3.1 x 3.1 x 3.1	1.15/32.6	54	108	216
HK	1.2 x 1.2 x 0.6/3.1 x 3.1 x 1.5	0.53/15	108	216	432
K	0.6 x 0.6 x 1.2/1.5 x 1.5 x 3.1	0.3/8.5	108	216	432

GB Multiplexing Instructions

Section I

*Stacking new GB Classic units above new GB Classic units
and old GB Classic units above new GB Classic units*

CAUTION:

- ◆ RISK OF PERSONAL INJURY, PROPERTY DAMAGE, EQUIPMENT FAILURE OR FIRE.
- ◆ Refer all maintenance to qualified personnel.
- ◆ Never operate this equipment with covers, panels or other parts removed or not properly secured.
- ◆ Use a suitable lifting means and be careful of sharp edges.

NOTE: Please refer to Section II of these instructions for installing a new GB Classic unit above an old GB Classic unit.

1. Remove cabinet panels from upper and lower ice makers.
2. Mount support clips on top side flanges of lower ice maker frame and position so the clip holes are aligned with the holes in the frame. (See Illustration "A") The lower flange of the front support clips must slide into the space between the top side flange of the ice maker and the top flange of the electrical box.

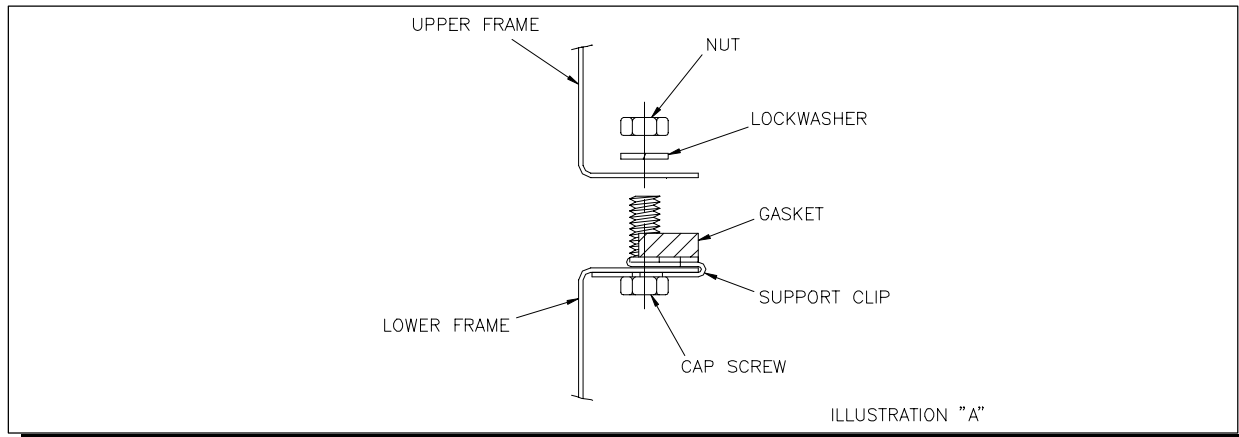

3. Apply gasket (supplied with kit) to the lower ice maker frame and cut to fit. (See Illustration "B") Place gasket over the supports clips already in position and pierce the gasket where it covers the mounting holes.

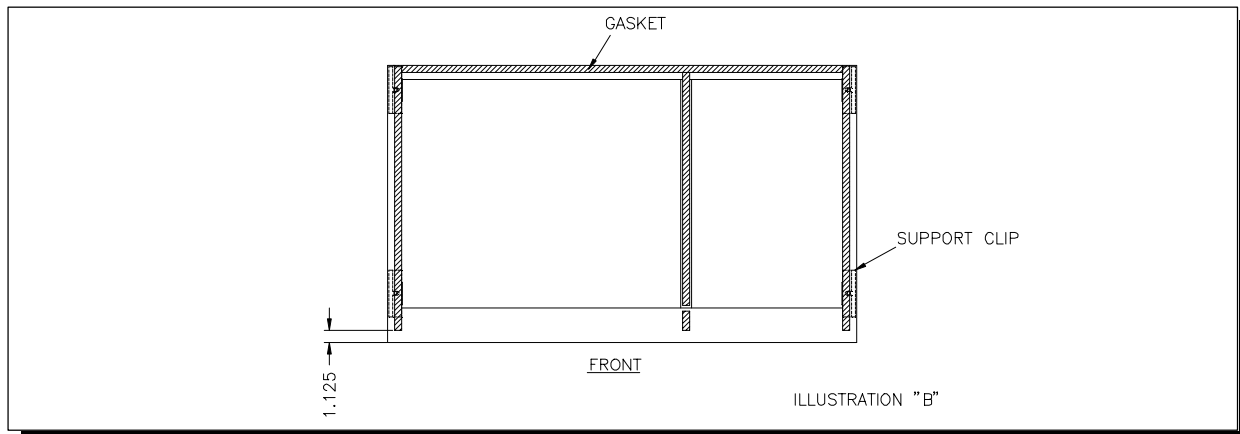

GB Multiplexing Instructions

4. Apply gasket to the top inside flange of the lower ice maker front cabinet panel. (See Illustration "C")

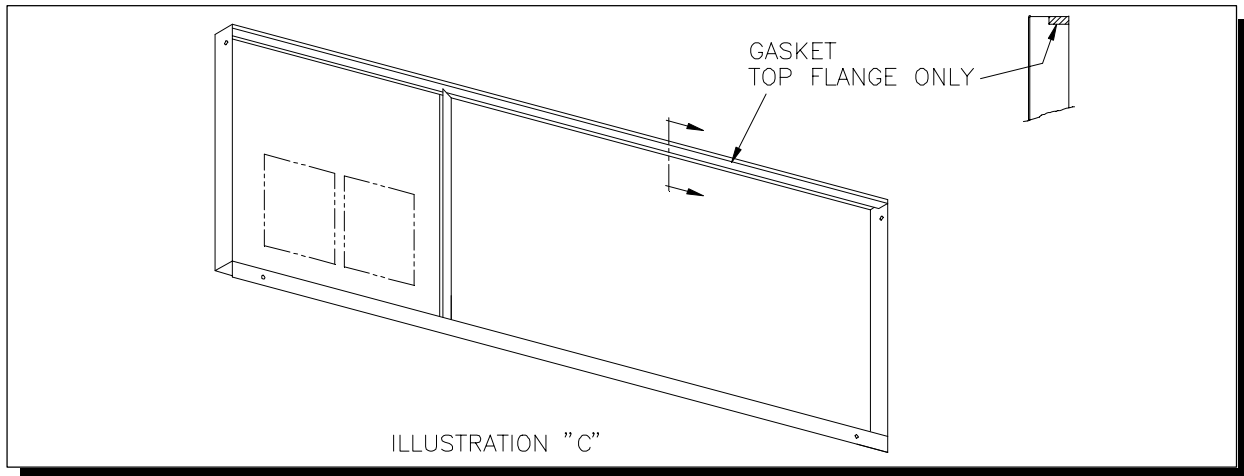

5. On installations with old GB Classic units it is necessary to drill (2) 5/16" dia. holes and enlarge (1) 3/16" dia. hole to 5/16" dia. in the bottom of the old Classic frame. (See Illustration "D") The transformer box will have to be moved temporarily in order to do this. The two right side holes can be drilled through the cond. unit pan from the underside, using the existing frame holes as a guide.

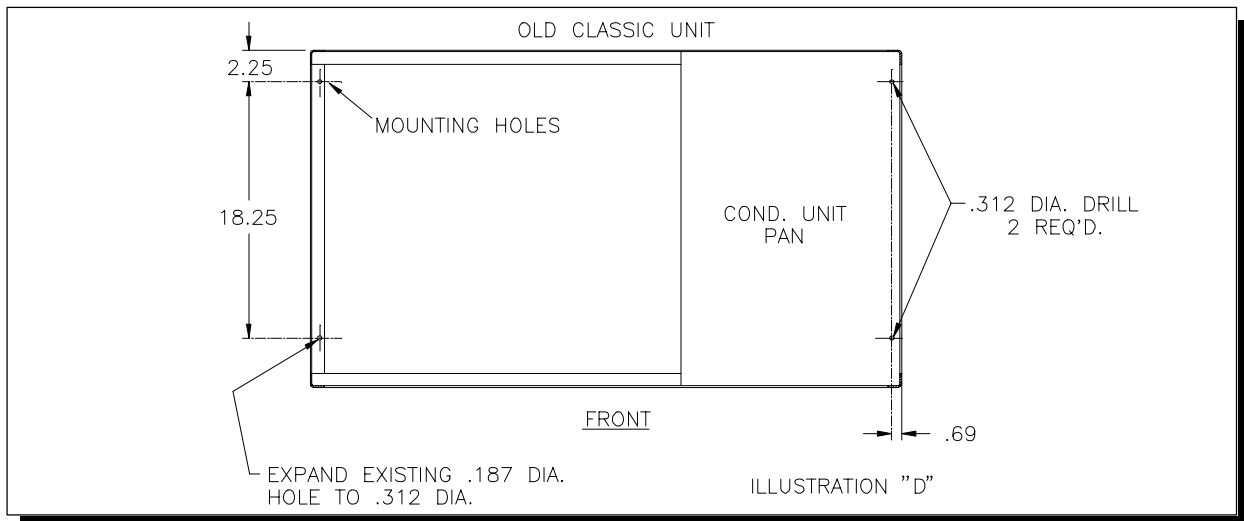

6. Position upper ice maker on lower unit and align mounting holes. Install cap screws, lock washers and nuts. (See Illustration "A") **CAUTION:** Support upper unit until all fasteners are secured.
7. Install the upper ice maker drain pan and ice chute. Connect the drain hose elbow assembly to the drain pan and route the drain hose through the rear of the lower ice maker. If the old GB Classic drain pan does not have a hose flange, exchange it with the pan from the new GB Classic unit.
8. Route the upper ice maker bin thermostat capillary tube or probe wire down to the lower ice maker chute opening for positioning. Keep capillary tube or wire toward the front of the partition wall out of the path of falling ice. Stacking a third ice maker will require a bin thermostat with a longer capillary tube (new GB

GB Multiplexing Instructions

Classic unit) or an extension cord (old GB Classic unit). Consult the factory for more information.

9. Install the Ice Chute (see instructions on Page 31), and side cabinet panels. On some early new GB Classic units it may be necessary to crimp the back catches of the side panels on the lower ice maker so the panel is held tight to the frame.
10. Follow start-up instructions to complete the installation.

Section II

Stacking new GB Classic units above old GB Classic units

1. Remove cabinet panels from upper and lower ice makers.
2. Mount inspection panel support angle to top front frame rail of lower (old GB Classic) unit with #8-32 screw, nuts and lock washers provided. (See Illustration "A")

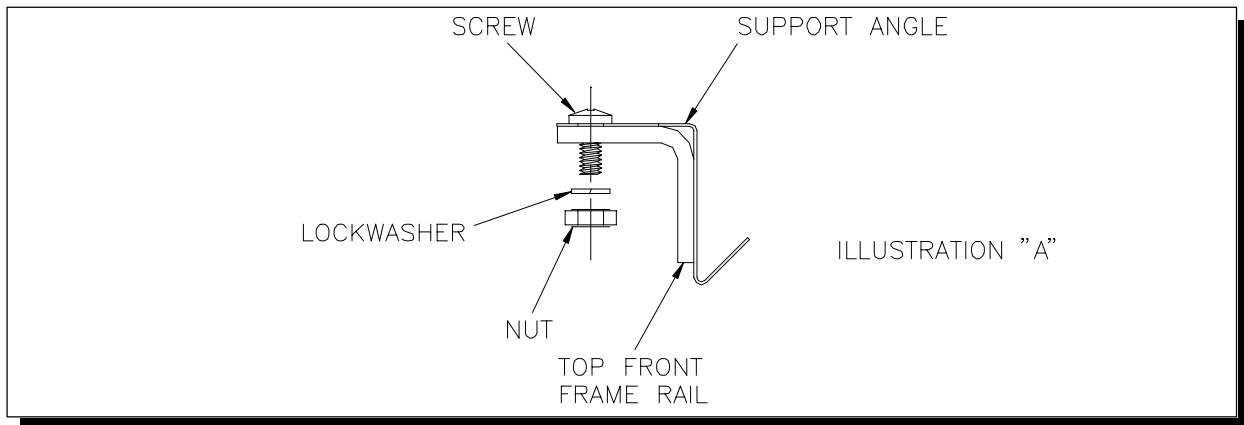

3. Apply gasket (supplied with kit) to the lower ice maker frame and cut to fit. Pierce gasket where it covers the mounting holes. (See Illustration "B")

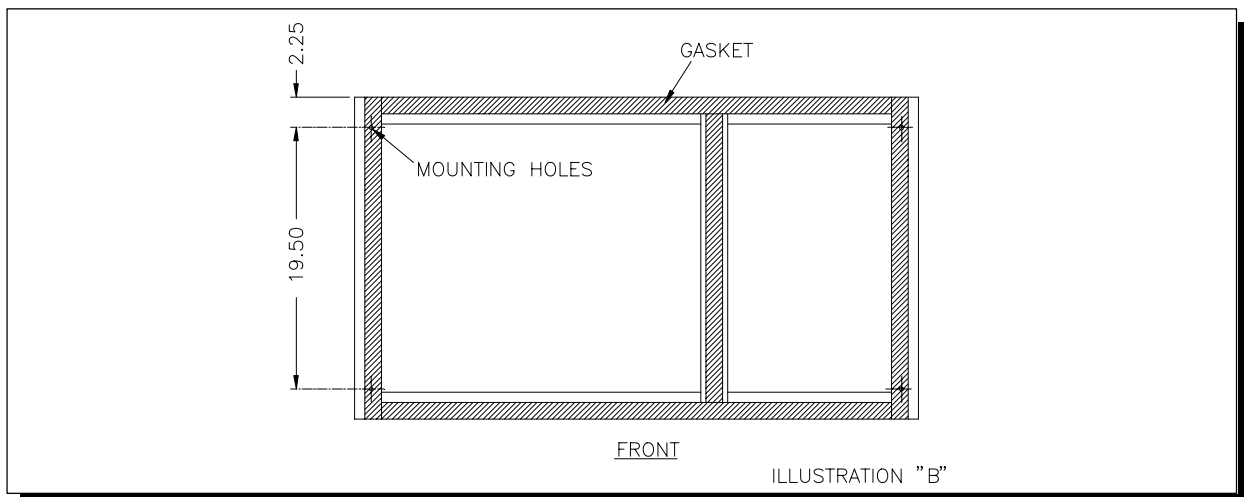

4. Install (4) 1/4-20 cap screws up through mounting holes of the lower ice maker and secure with (4) nuts.

GB Multiplexing Instructions

5. Position upper ice maker over lower unit and lower in place. Secure with (4) nuts. (See Illustration "C") **CAUTION:** Support upper unit until all fasteners are secured.

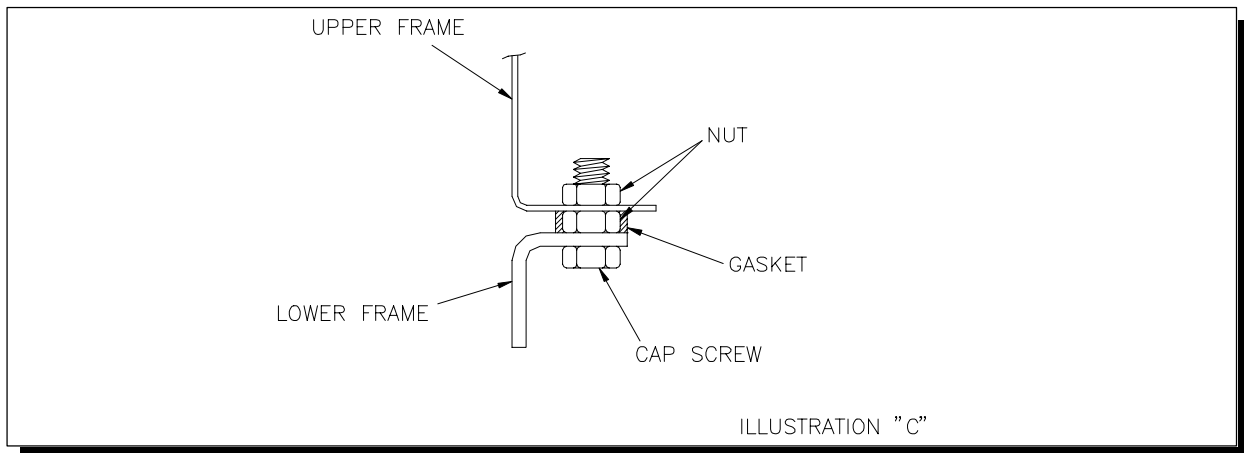

6. Route upper ice maker bin thermostat capillary tube through grommets hole in the partition wall, down to the lower ice maker chute opening for positioning. Keep capillary tube toward the front of the partition wall out of the path of falling ice. Stacking a third ice maker will require a bin thermostat with a longer capillary tube. Consult the factory for more information.
7. Install the upper ice maker drain pan and ice chute. Connect the drain hose elbow assembly to the drain pan and route the drain hose through the rear of the lower ice maker. If a 1" dia. hole has not been provided in the rear gusset of the lower ice maker, it will have to be provided by the installer. (See Illustration "D")

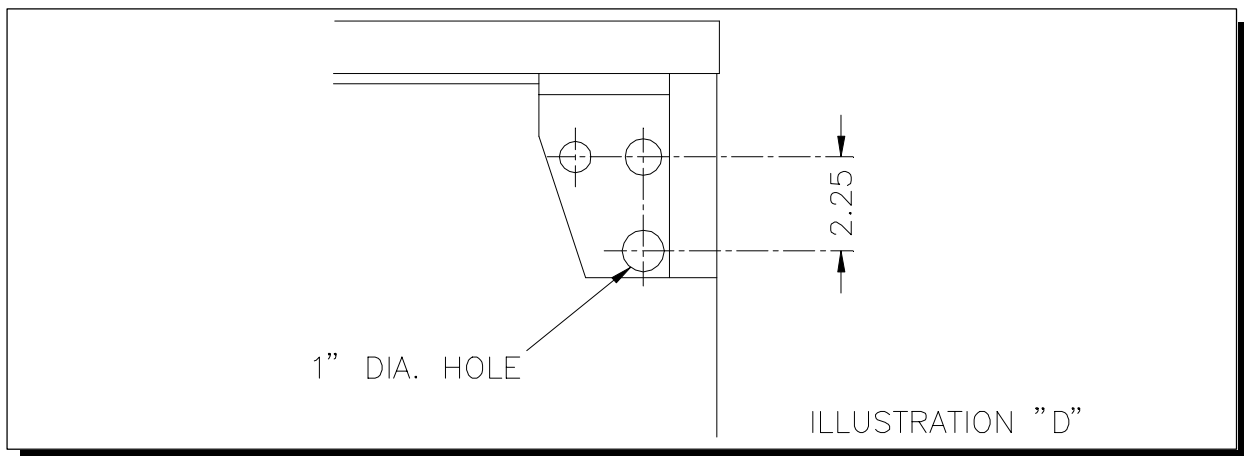

8. Install the Ice Chute (see instructions on Page 31), and side cabinet panels.
9. Follow start-up instructions to complete the installation.

Ice Chute Installation

The stainless steel ice chute provided with 102 1207 01 GB Model Stacking Kits is to be installed in all except the TOP cuber in the stack. See the Ice Chute installation instructions on Page 31 for details.

GT3XX Multiplexing Instructions

Section I

NOTE: The next Two Sections only apply to GT3XX Cubers, the GT55X Cuber is ***NOT*** stackable

CAUTION:

- ◆ RISK OF PERSONAL INJURY, PROPERTY DAMAGE, EQUIPMENT FAILURE OR FIRE.
- ◆ Refer all maintenance to qualified personnel.
- ◆ Never operate this equipment with covers, panels or other parts removed or not properly secured.
- ◆ Use a suitable lifting means and be careful of sharp edges.

Stacking new GT3XX Classic units above new GT3XX Classic units

NOTE: Please refer to Section II of these instructions for installing a new GT *Classic* unit above an old GT *Classic* unit and Section III for installing an old *Classic* (pre-1992 GT400, 500, 600) above a new GT *Classic* unit.

1. Remove cabinet panels from upper and lower ice makers.
2. Apply gasket (supplied with kit) to the lower ice maker frame and cut to fit. (See Illustration "A")

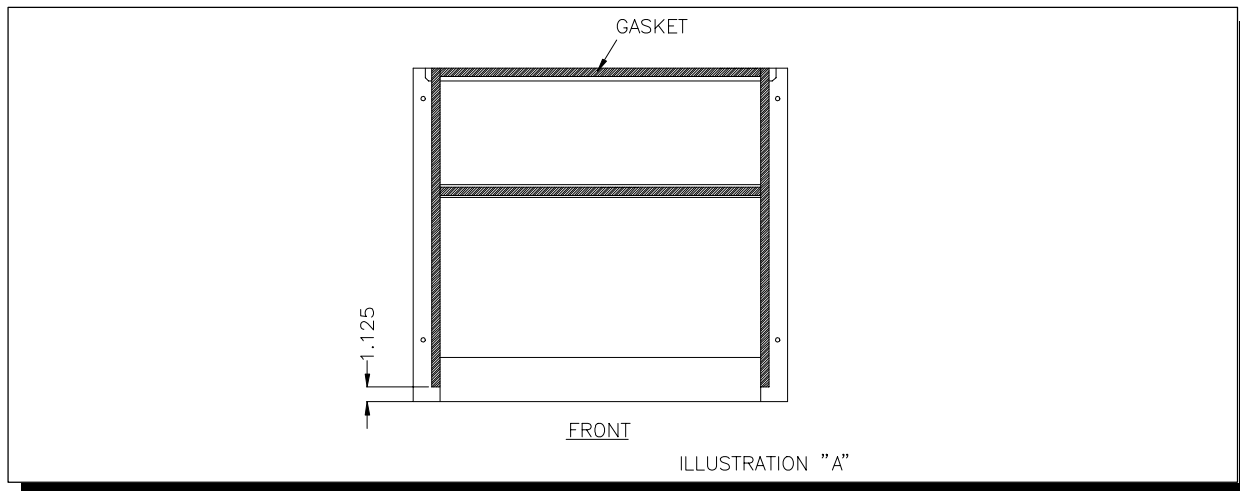

3. Install (4) 1/4-20 cap screws up through mounting holes of the lower ice maker and secure with (4) nuts. (See Illustration "B")

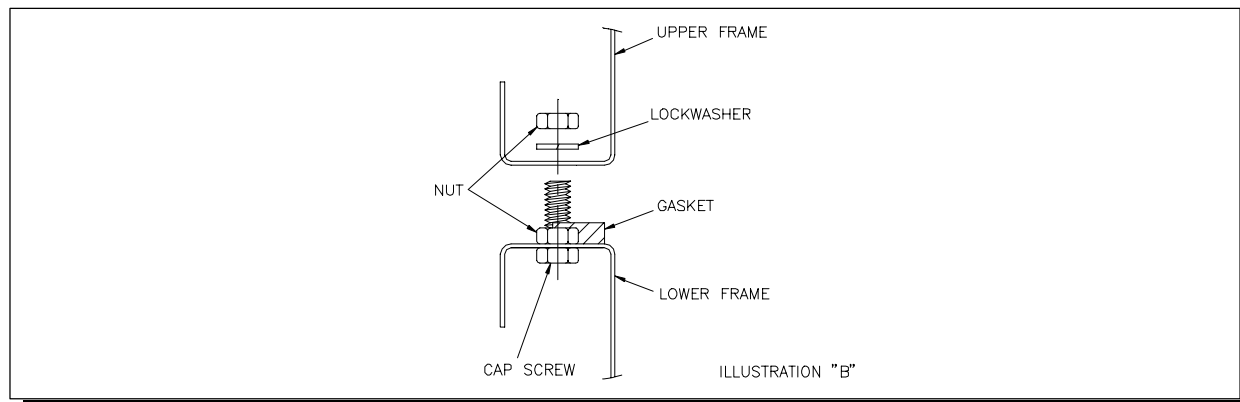

GT3XX Multiplexing Instructions

4. Position upper ice maker over lower unit and lower in place. Install lock washers and secure with (4) nuts. (See Illustration "B") **CAUTION:** Support upper unit until all fasteners are secured.
5. Hang cube gate on lower ice maker cam shaft. (See Illustration "C")

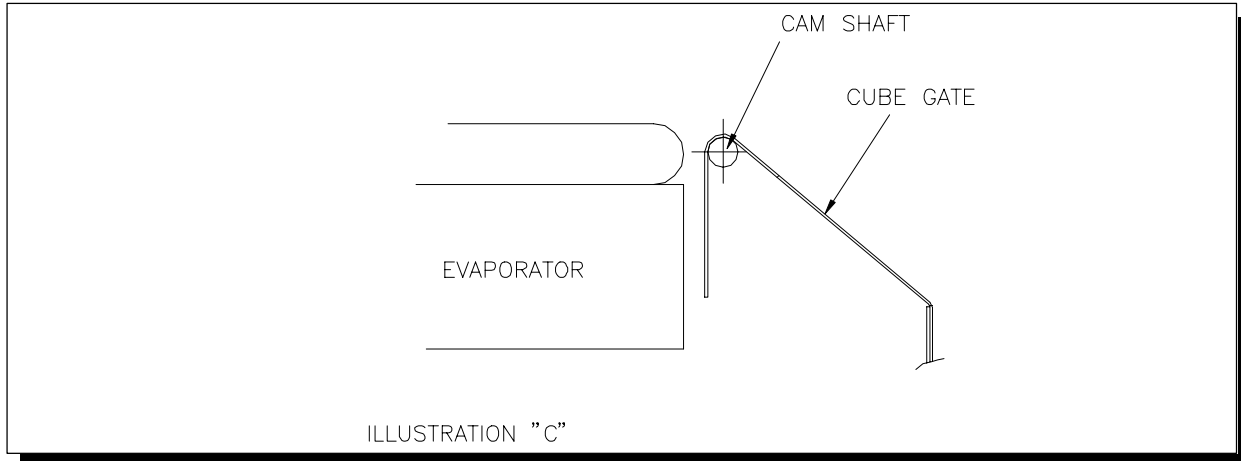

6. Remove the standard drain pan/chute from the upper ice maker and replace with the Multiplex model (supplied with kit). Connect the drain hose to the drain pan nipple, and route it down so that it spills on the lower ice maker drain pan. Secure the hose with a clamp.
7. Route the upper ice maker bin thermostat capillary tube through the grommetted hole in the right side wall, down to the lower ice maker chute opening for positioning. Keep capillary tube toward the front of the side wall out of the path of falling ice. Stacking a third ice maker will require a bin thermostat with a longer capillary tube. Consult the factory for more information.

Section II

Stacking new GT3XX Classic units above old GT30X Classic units

1. Remove cabinet panels from upper and lower ice makers.
2. Mount inspection panel support angle to top front frame rail of lower (pre-1992 GT Classic) unit with #8-32 screws and nuts provided. (See Illustration "A")

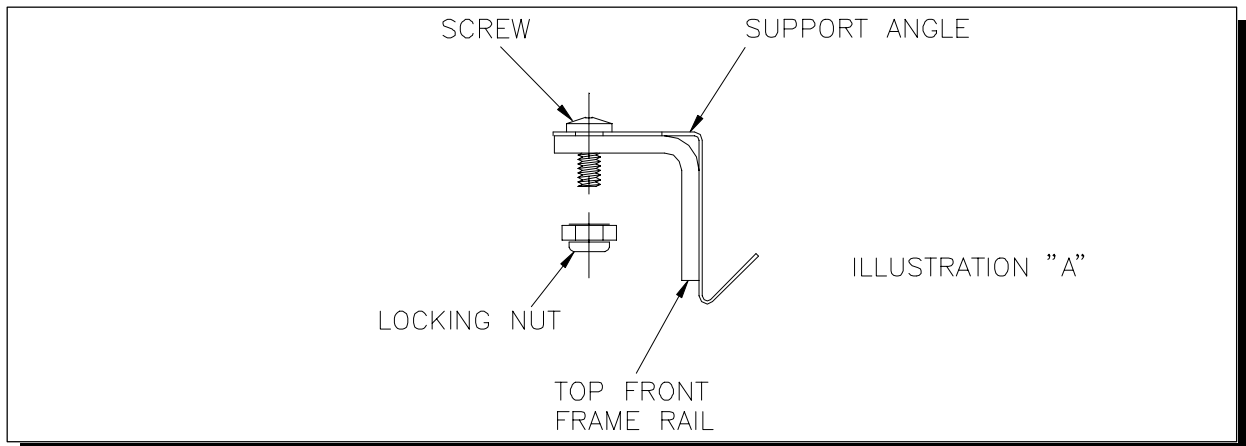

GT3XX Multiplexing Instructions

3. Apply gasket (supplied with kit) to the lower ice maker frame and cut to fit. Pierce gasket where it covers the mounting holes. (See Illustration "B")

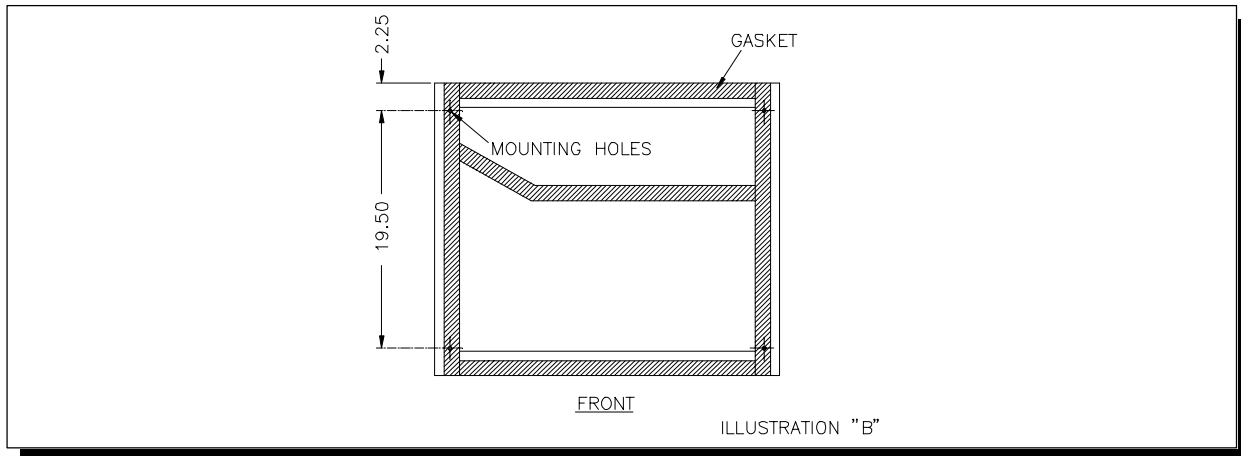

4. The new *Classic* unit drain pan support angle must be modified for use with pre-1992 *Classic* units. Remove the standard drain pan/chute from the new *Classic* unit. Locate the notched section of the support angle, clip the tabs and break out of unit. (See Illustration "C")

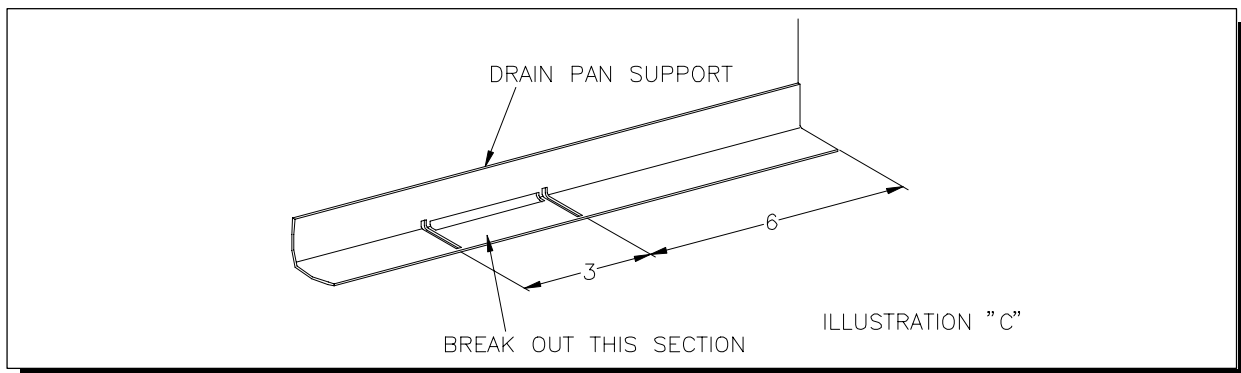

5. Install (4) 1/4-20 cap screws up through mounting holes of the lower ice maker and secure with (4) nuts.
6. Position upper ice maker over lower unit and lower in place. Install lock washers and secure with (4) nuts. (See Illustration "D") **CAUTION:** Support upper unit until all fasteners are secured.

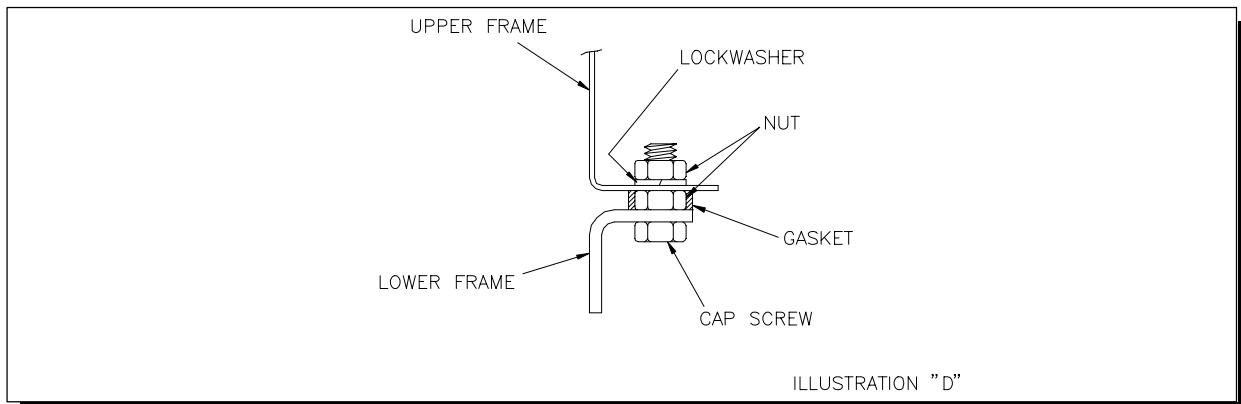

GT3XX Multiplexing Instructions

7. Hang cube gate on lower ice maker cam shaft. (See Illustration "E")

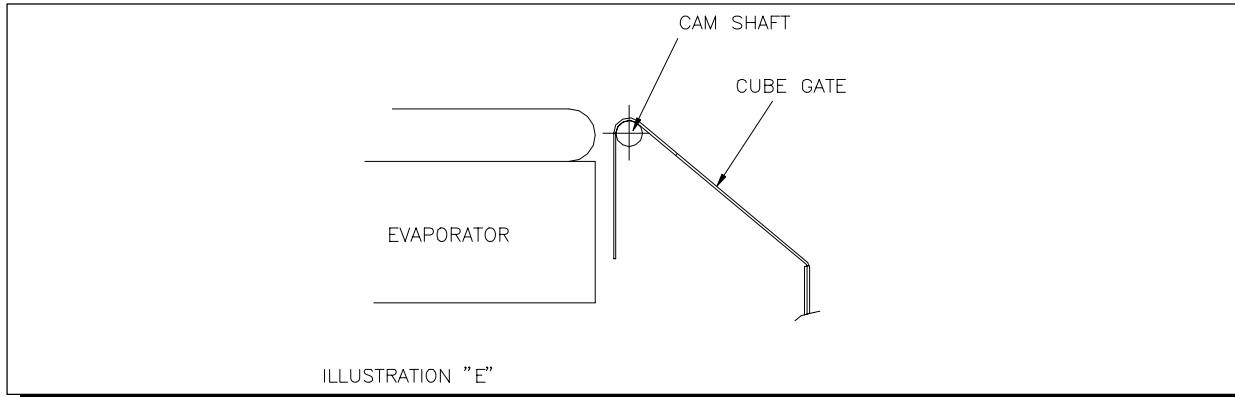

8. Modify the multiplex chute (supplied with kit). Carefully separate the chute from the drain pan with an utility knife and discard the chute section. (See Illustration "F")

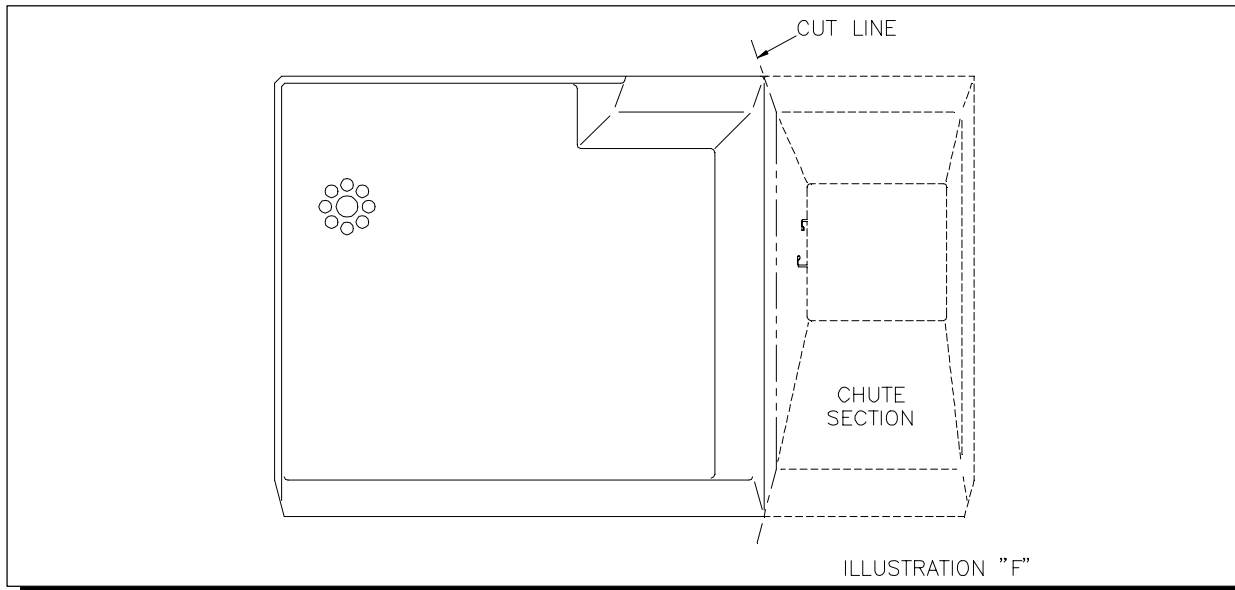

9. Install drain section in upper ice maker and move to the left side. Install chute (supplied with kit) and position to the right side of the drain pan, under the drain pan lip. (See Illustration "G") Route upper ice maker bin thermostat capillary

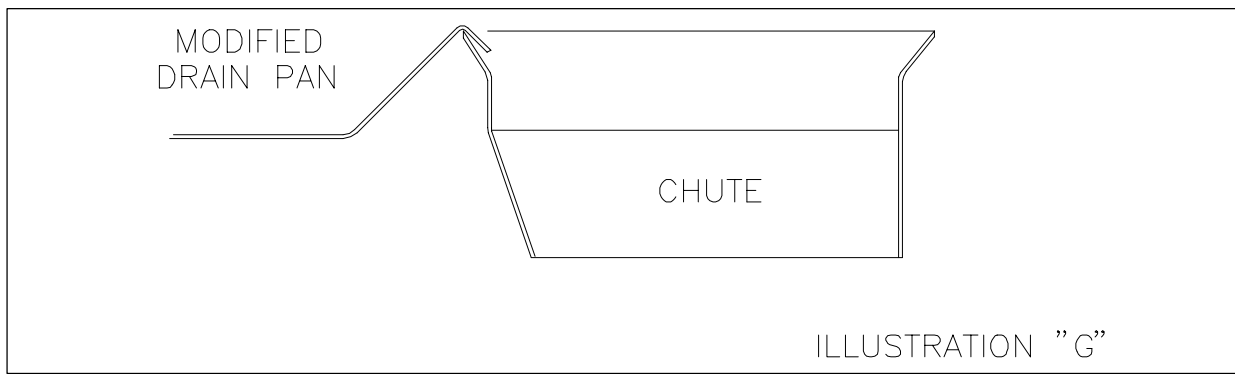

GT3XX Multiplexing Instructions

tube through grommetted hole in the partition wall, down to the lower ice maker chute opening for positioning. Keep capillary tube toward the front of the partition wall out of the path of falling ice. Stacking a third ice maker will require a bin thermostat with a longer capillary tube. Consult the factory for more information.

10. Install the side cabinet panels and follow start-up instructions included with the ice maker to complete installation.

Section III

Stacking old (pre-1992) GT Classic (GT400, 500, 600) units above new GT3XX Classic units

1. Remove cabinet panels from upper and lower ice makers.
2. Apply gasket (supplied with kit) to the lower ice maker frame and cut to fit. (See Illustration "A")

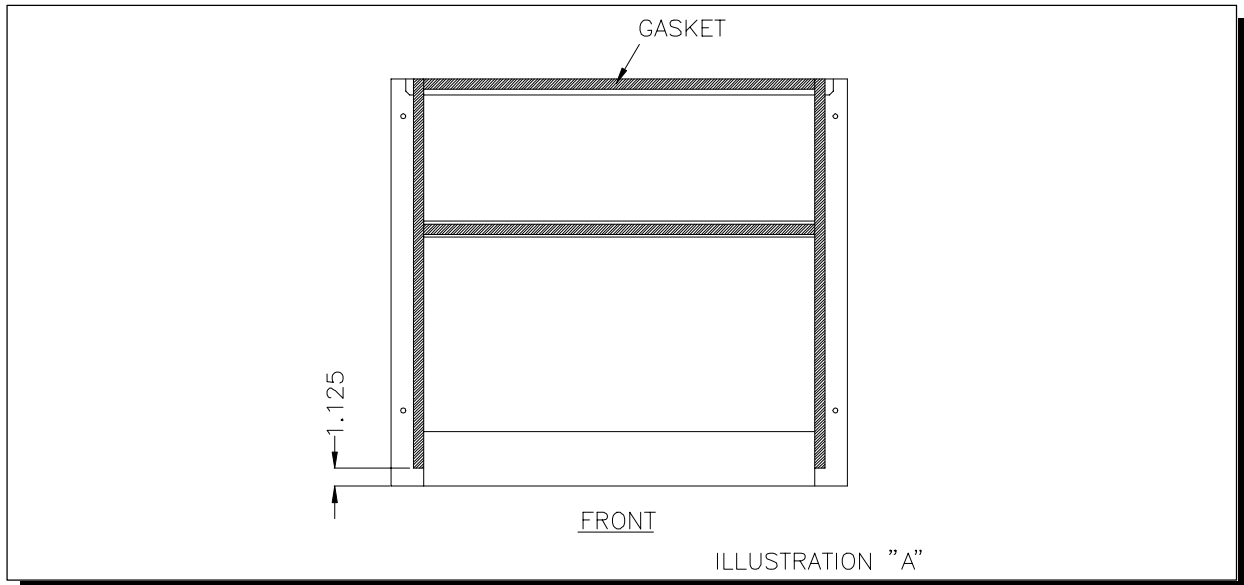

3. Install (4) 1/4-20 cap screws up through mounting holes of the lower ice maker and secure with (4) nuts. (See Illustration "B")

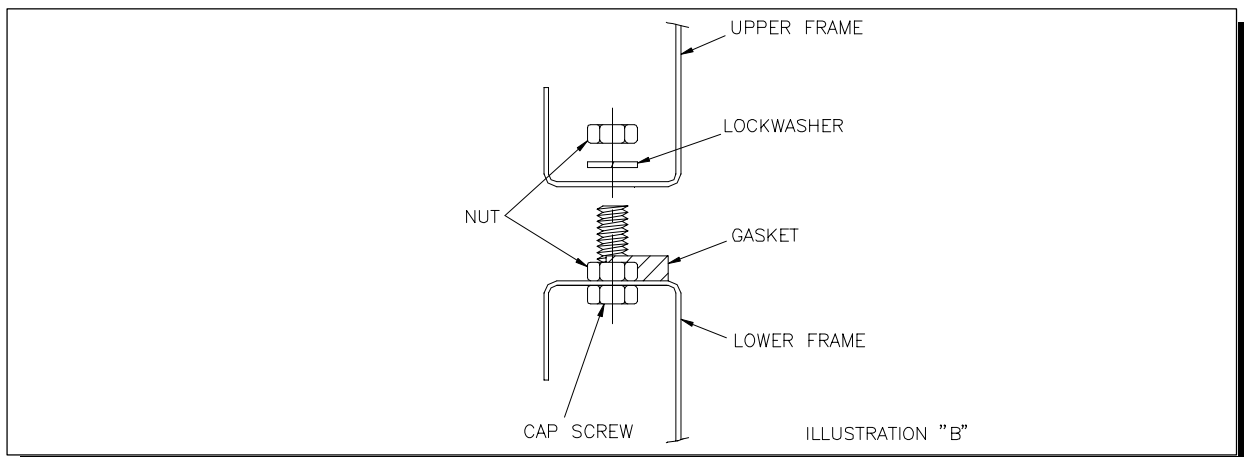

GT3XX Multiplexing Instructions

- To allow for proper mounting, it is necessary to enlarge a 3/16" dia. hole in the bottom of the old GT Classic frame to 5/16" dia. (See Illustration "C")

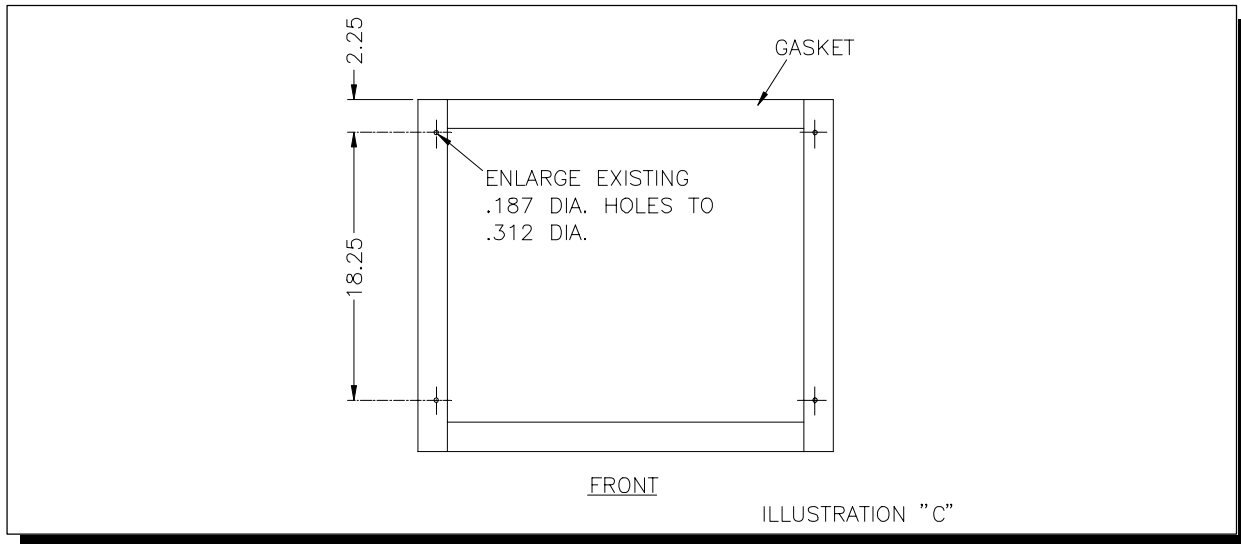

- Position upper ice maker over lower unit and lower in place. Install lock washers and secure with (4) nuts. (See Illustration "B") **CAUTION:** Support upper unit until all fasteners are secured.
- Hang cube gate on lower ice maker cam shaft. (See Illustration "D")

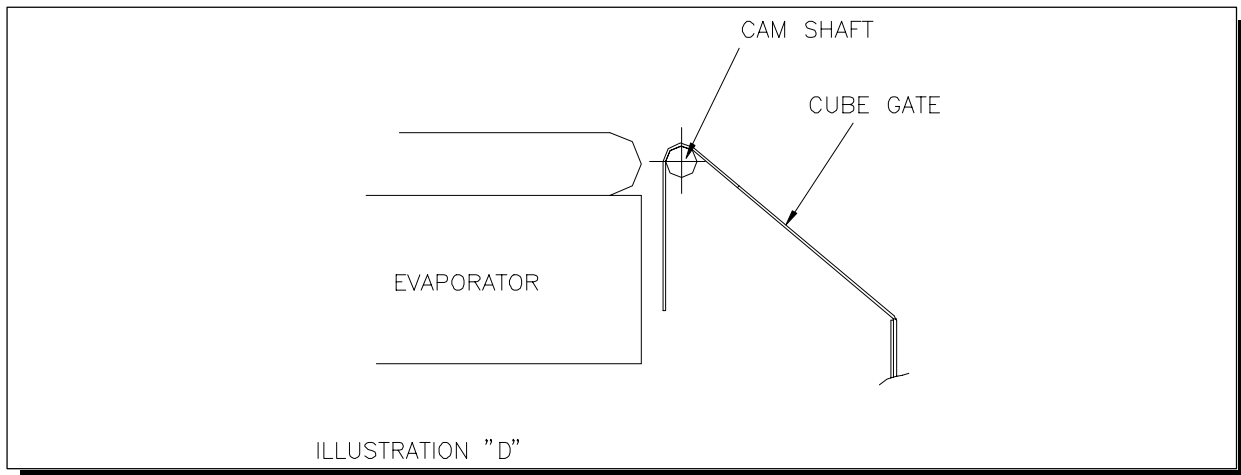

- Remove the standard drain pan and chute from the upper ice maker and replace with the plastic drain pan and the multiplex chute. (supplied with kit) Connect the drain hose to the drain pan nipple, and route it down so that it spills on the lower ice maker drain pan. Secure the hose with a clamp.
- Route the upper ice maker bin prove wire down to the lower ice maker chute opening for positioning. Keep capillary tube toward the front of the side wall, out of the path of falling ice.

GB Multiplex Ice Chute Installation Instructions

GB MULTIPLEX CHUTE INSTALLATION INSTRUCTIONS

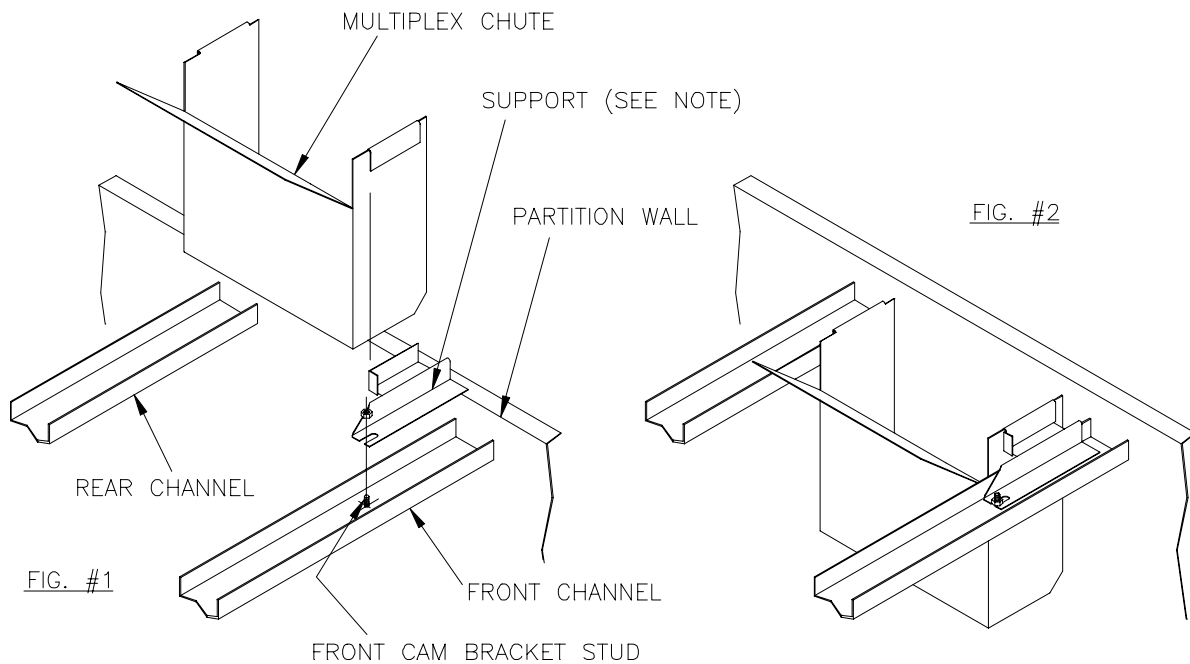

NOTE— THE CHUTE IS INSTALLED OVER THE REAR CHANNEL FLANGE IN ALL APPLICATIONS. TWO SUPPORTS ARE PROVIDED FOR MOUNTING TO THE FRONT CHANNEL. THE SUPPORT WITH THE WIDER SPAN AND DEEPER MOUNTING FLANGE IS FOR ELECTRO-MECHANICAL AND ELECTRONIC MODELS ONLY. THE OTHER SUPPORT IS FOR CLASSIC CUBER APPLICATIONS.

- 1- DISCONNECT POWER SUPPLY. REMOVE THE FRONT ACCESS PANEL AND PLASTIC ICE CHUTE FROM THE UPPER CUBER. THE WATER PLATE MUST BE IN THE CLOSED POSITION.
- 2- LOOSEN OR REMOVE THE NUT FROM THE FRONT CAM BRACKET STUD OF THE LOWER CUBER.
- 3- POSITION THE PROPER ICE CHUTE SUPPORT SO THAT THE SLOT IN THE MOUNTING FLANGE ENGAGES THE CAM BRACKET STUD. REINSTALL THE NUT (IF REMOVED) BUT DO NOT TIGHTEN AT THIS TIME.
- 4- INSTALL THE MULTIPLEX CHUTE AND POSITION IT BETWEEN THE SUPPORT CHANNELS OF THE CUBER. THIS IS MOST EASILY ACCOMPLISHED BY POSITIONING THE CHUTE HORIZONTALLY, WITH THE ANGLED FLANGE UP AND TOWARD THE PARTITION WALL OF THE CUBER. PICK UP THE RIGHT FRONT CORNER OF THE PLASTIC DRAIN PAN AND INSTALL THE CHUTE BETWEEN THE SUPPORT CHANNELS. ROTATE THE CHUTE COUNTER CLOCKWISE TO THE POSITION ILLUSTRATED IN FIGURE #1.
- 5- DROP THE CHUTE DOWN INTO POSITION, WITH ITS HANGERS ENGAGING THE REAR CHANNEL FLANGE AND THE ICE CHUTE SUPPORT FLANGE.
- 6- SLIDE THE CHUTE TO THE RIGHT AGAINST THE PARTITION WALL. SLIDE THE ICE CHUTE SUPPORT TO THE RIGHT UNTIL THE STOP IS AGAINST THE FRONT HANGER EDGE. (SEE FIGURE #2) TIGHTEN THE NUT ON THE FRONT CAM BRACKET STUD TO SECURE THE CHUTE IN POSITION.
- 7- INSTALL THE PLASTIC ICE CHUTE AND REPLACE THE FRONT ACCESS PANEL.

Operational Components

- ◆ 1992 and later models
- ◆ Refer to the specific model wiring diagrams in addition to this text.
- ◆ The following list of components and their functions is common to all models except as noted in the text.

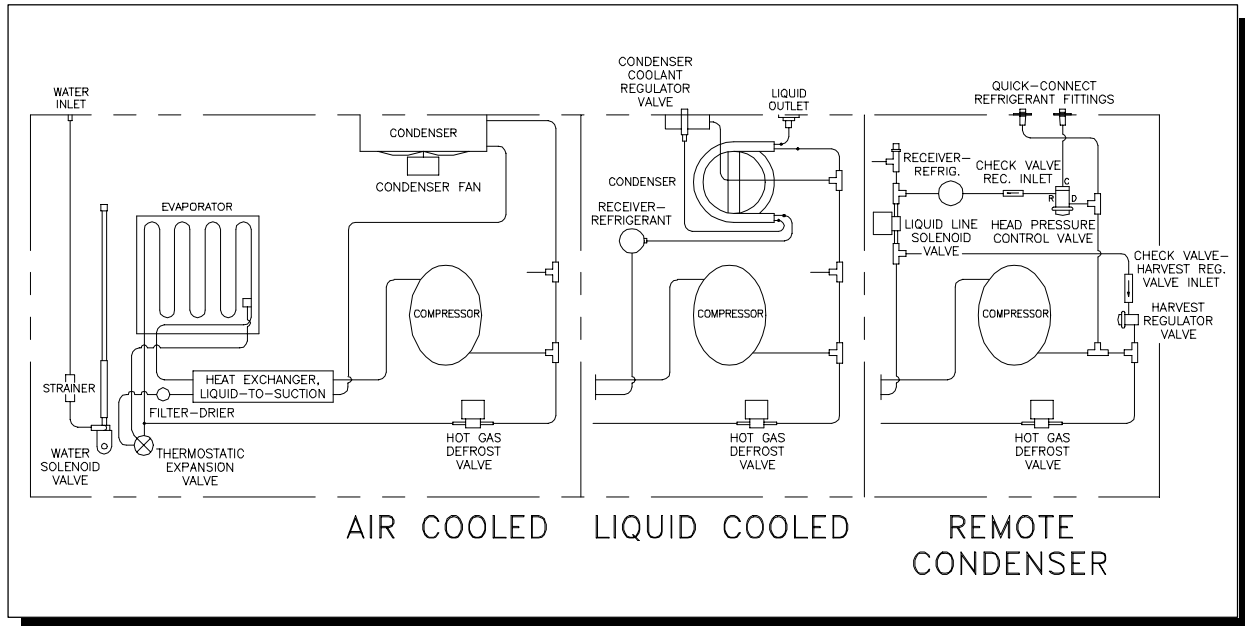

1. **Compressor:** All models are provided with a refrigerant compressor which is rated for the electrical and refrigerant characteristics indicated on the *Nameplate* located on the rear of the cuber.
2. **Condenser:** All models, except those which use a remote condenser (R), are provided with a self-contained refrigerant condenser, either forced air (A) or liquid (W) cooled, rated for the refrigerant type and pressure indicated on the *Nameplate*. Remote condenser (R) models are intended for use with remotely-installed forced air-cooled condensers meeting the requirements indicated on the *Nameplate*.
3. **Condenser Fan:** Air cooled models (A) are provided with a condenser fan motor and blade combination which have the proper air volume capacity for the refrigeration system and minimum ventilation noise level. Note the installation clearance requirements for each model.
4. **Condenser Coolant Regulator Valve:** Liquid cooled models (W) are provided with a mechanical valve to regulate the flow of liquid coolant through the condenser. This compensates for variations in the refrigeration load and variations in coolant temperature to provide maximum efficiency. High-side refrigerant pressure determines the valve modulation. Refer to the **Controls and Adjustments** section for further information.
5. **Heat Exchanger, Liquid-to-Suction:** All models are provided with a tube-in-tube heat exchanger which should sub-cool the liquid refrigerant approximately 12° F. during the freeze cycle.

Operational Components

6. **Filter-Drier:** All models are provided with a liquid-line filter-drier which is rated for the refrigerant type and high-side design pressures indicated on the *Nameplate*.
7. **Thermostatic Expansion Valve (TEV):** All models are provided with mechanical TEV's which are suitable for the refrigeration load and the refrigerant type indicated on the *Nameplate*. GB1220/1240/1250 Dual evaporator models employ two TEV's. See the **Controls and Adjustments** section for further information.
8. **Evaporator:** All models are provided with a plated copper evaporator, two evaporators in GB1220/1240/1250 models, which determines the ice cube size which will be produced. Each cube is formed in an individual cell with five freezing surfaces. In order to change the size of ice produced, the evaporator, and possibly the water plate, must be changed. The evaporator(s) is(are) mounted horizontally with the open side down, and ice is harvested by gravity without mechanical assistance. The small holes in part of the top surface allow air in as the ice falls out. Refrigerant is carried by the serpentine coil of plated copper tubing on the top surface of the evaporator.
9. **Water Solenoid Valve:** Each evaporator/water plate/tank section is provided with a line-voltage solenoid valve which supplies all ice making and rinsing water to the cuber. See the **Controls and Adjustments** section for details regarding how and when the valve is energized.
10. **Hot Gas (Defrost) Valve:** All models are provided with a line-voltage hot gas solenoid valve which routes the compressor discharge gas to the evaporator as required, for harvesting ice or for cold-water effect compensation. See the **Controls and Adjustments** section for details regarding how and when this valve is energized.
11. **Liquid Line Solenoid Valve:** Remote condenser models (R) are provided with a line-voltage liquid line solenoid valve which is energized only while the 'ICE-OFF-WASH' switch is in the 'ICE' position. The purpose of this valve is to allow the low side to pump down during off periods. See the wiring diagrams and the **Control and Adjustments** section for details regarding how this valve is controlled.
12. **Head Pressure Control Valve (Low Ambient):** Remote condenser models (R) are provided with a non-adjustable mechanical pressure regulating valve which closes off the condenser liquid return and bypasses compressor discharge gas to the receiver during cool ambient temperature operation (below 75° F.). During this function, liquid refrigerant floods the condenser coil while the receiver liquid pressure is maintained high enough for effective refrigeration.
REMOTE CONDENSER MODELS ARE NOT FACTORY CHARGED TO THE MAXIMUM AND WILL LIKELY REQUIRE ADDITIONAL REFRIGERANT CHARGE AT INSTALLATION. See the **Installation Guidelines** section for determining the proper charge and for calculating the additional charge required for the expected lowest ambient temperature operating conditions.

Operational Components

◆ **WARNING: RISK OF SERIOUS DAMAGE TO THE COMPRESSOR!**

Insufficient refrigerant charge will result in repeated pump-down cycles until the compressor overloads or fails.

13. **Harvest Regulator Valve:** Remote condenser models (R) are provided with a non-adjustable mechanical pressure regulating valve. The purpose of this valve is to maintain high-side refrigerant mass for adequate heat transfer when the hot gas valve is open, if the discharge pressure falls below 150 psig. This valve only functions as required, and it is not likely to open when the condenser ambient temperature is above 75° F.
14. **Quick-Connect Refrigerant Fittings:** Remote condenser models (R), **Kold-Draft**® remote condensers and **Kold-Draft**® remote line sets are provided with re-sealable fittings for refrigerant line connections. **Kold-Draft**® condensers and line sets are VAPOR-CHARGED only.
15. **Strainer-Water Inlet:** All models are provided with an in-line potable supply water strainer. This strainer is not intended to remove supply water turbidity, which is inherent to the water supply, but rather to protect the water solenoid valve(s) from damage due to an unusual event, such as follows a water shut-off for plumbing work. If the need for cleaning the strainer is frequent, an external water filter should be provided. The strainer may be cleaned without disassembly of tubing.
16. **Receiver-Refrigerant:** Liquid cooled (W) and Remote condenser (R) models are provided with receiver tanks, which are rated for the refrigerant charge type, amount and pressures indicated on the *Nameplate*. Air cooled models (A) do not employ a receiver.
17. **Check Valve-Receiver Inlet:** Remote condenser models (R) are provided with a check valve at the receiver inlet. The purpose of this valve is to minimize refrigerant backflow to the condenser during harvest and off cycles and to maintain receiver pressure during harvest for proper operation of the harvest regulator valve with low condenser ambient temperatures.
18. **Check Valve-Harvest Regulator Valve Inlet:** Remote condenser models (R) are provided with a check valve in the supply tubing to the harvest regulator valve. The purpose of this valve is to avoid migration of high-side refrigerant to the liquid line during off cycles, when the high-side pressure is lower than the setting of the harvest regulator valve. Without this check valve, the pumpdown controller (see the **Controls and Adjustments** section) would not function properly.
19. **Check Valve-Hot Gas Line:** GB1220/1240/1250 Dual evaporator models are provided with a check valve in the hot gas tubing to the Master (upper) evaporator. The purpose of this valve is to prevent refrigerant migration from the upper to the lower evaporator during freeze cycles, which can occur due to gravity. Frost on the hot gas tubing indicates refrigerant migration from the lower to the upper evaporator, which is due to refrigeration imbalance. See the **Service and Troubleshooting** section for more details.

Operational Components

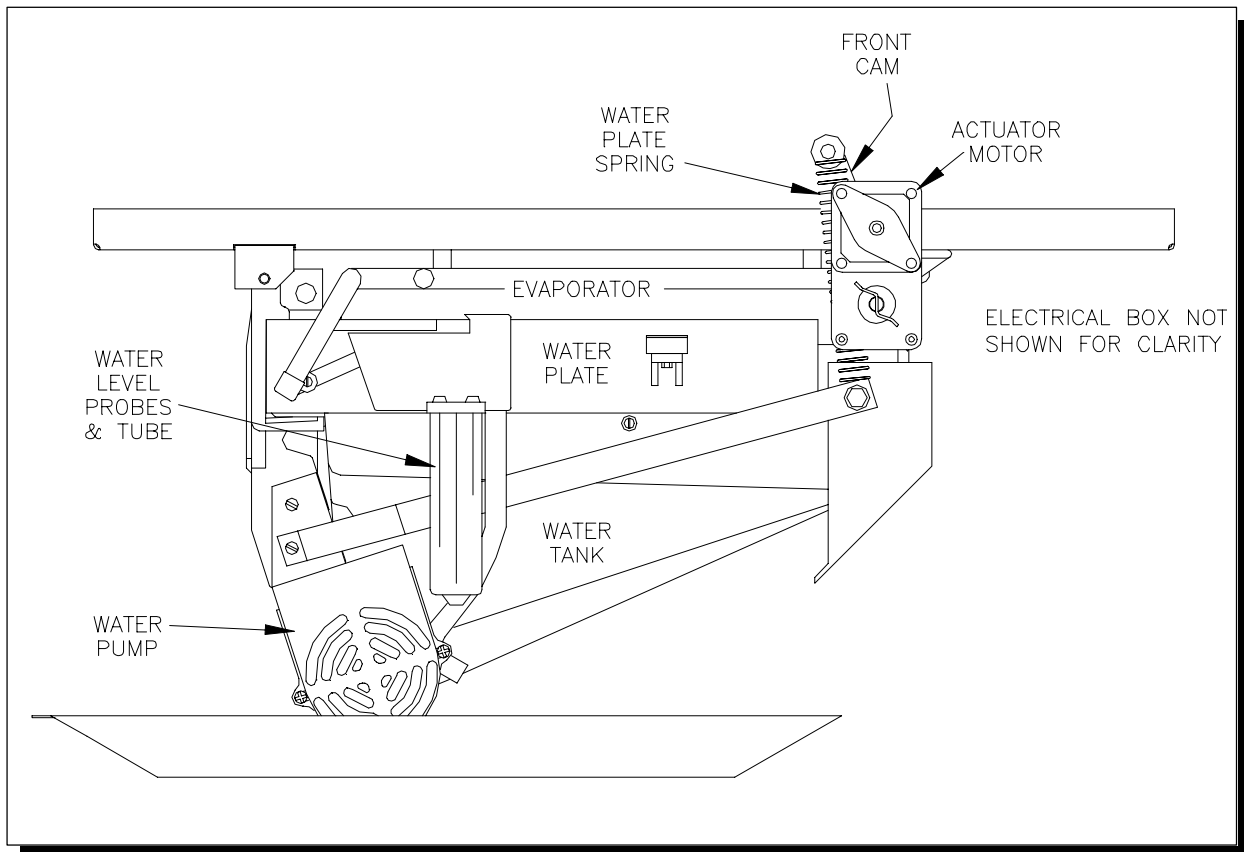

20. **Water Plate:** All models are provided with a plastic water plate beneath each evaporator. The flat top surface of the water plate is provided with holes for injection of water into each evaporator cell and for return of unfrozen water to the water circulation system. This surface forms the sixth surface of the cubes and is spaced from the evaporator so that a thin, uniform web of ice is formed. The cubes are connected together to promote harvest in one or more large sections, rather than individually which would cause excessive melting and require a much longer harvest time.
21. **Water Tank:** A plastic water tank, or sump, is attached to the bottom of each water plate. The volume of this tank contains enough water for a single batch of ice, along with some excess water to carry away the impurities from the water supply. The impurities are excluded from the ice by the constant circulation during the freezing cycle. Unfrozen water is returned to the tank, from the water plate, during the freeze cycle. The excess water, with concentrated impurities, is drained from the system each cycle along with the fresh water which rinses the water plate while it is opening for harvest.
22. **Water Pump:** Each evaporator/water plate/tank section is provided with a water pump. The purpose of this pump is to recirculate the ice-making water constantly, through the water plate, during the freeze cycle. The pump does not run during the harvest cycle. All water pumps are designed exclusively for the application electrical requirements and ice maker type (GB/GT) to provide the proper water circulation rate. See the **Controls and Adjustments** section for details regarding how and when the pump is energized.

Operational Components

23. **Actuator Motor and Cams:** The opening and closing of the water plate for freezing and harvesting cycles is accomplished by the actuator motor. The connection between the actuator motor and water plate is through plastic cams and springs. When the water plate is closed for freezing, the cam lever with the spring attached is in the noon position with the spring slightly stretched, keeping the water plate tight against the cam surface at the motor coupling. See the **Service and Troubleshooting** section for alignment and adjustments. At the beginning of a harvest cycle, the actuator motor runs counter-clockwise (CCW, facing the cuber) and the cam surface forces the water plate away from the ice. As the motor continues to run, the cam lever travels to the 7 O'Clock position when the motor stops with the water plate open for harvesting the ice. After the ice has been harvested, the actuator motor runs clockwise (CW) to turn the cam levers back to the noon position for the next freeze cycle.

CAUTION: Overfreezing, so that more cam force is required to separate the water plate from the ice causes undue component wear. See the **Controls and Adjustments** and **Service and Troubleshooting** sections for proper adjustments to avoid this condition.

Controls and Adjustments

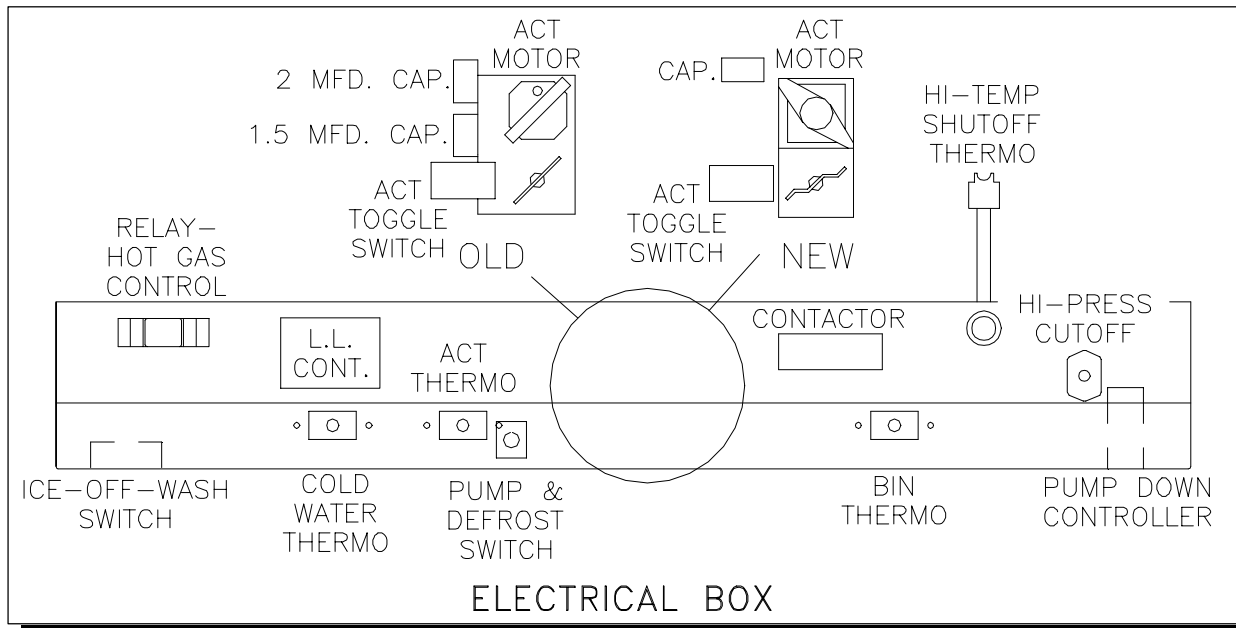

- Bin Thermostat:** The bin thermostat provides power to the 'ICE-OFF-WASH' switch. See the **GB & GT Cuber Installation Instructions** for the proper placement and securing of the bin thermostat capillary tube.

Adjustment of this control can be made with the 'ICE-OFF-WASH' switch (see below) in the 'WASH' position to avoid unnecessary compressor cycling. While holding some ice against the end of the capillary tube the cuber should shut down within one minute. Turn the adjustment warmer (CCW) to shut down sooner, or colder (CW) to delay shut down (may be necessary in cool ambients to avoid premature shut down). Ideally, the shut down will occur after the ice has harvested and before the water plate closes. This adjustment should be checked with the ice storage area full and with the unit at typical ambient temperature.

Note: The compressor control circuit in remote condenser models (R) is supplied upstream from the bin thermostat in order to allow the low-side pumpdown cycle during off periods.
- High Temperature Shutoff Thermostat:** Before October, 1996 some models were provided with a high temperature shutoff thermostat on the suction line near the compressor inlet. This control provides power to the bin thermostat and to the compressor circuit pressure switches in remote condenser (R) models. If the suction line temperature rises to 130° F. due to a refrigeration problem, such as the hot gas valve mechanically stuck open, power will be shut off to all operating components of the cuber including the compressor in remote condenser models (R). This control will automatically reset when the suction line cools to 110° F., restoring power to the operating components.
- ICE-OFF-WASH Switch:** The 'ICE' position connects power from the bin thermostat to all control circuits, except the compressor circuit in remote condenser (R) models, and to the respective electrical operating components except the compressor motor (and condenser fan motor in self-contained air cooled models) which is (are) powered by the contactor.

The 'WASH' position allows all electrical operating components to be powered without the compressor running for in-place cleaning or test procedures (see

Controls and Adjustments

additional details under **Pump-Down Controller, Relay-Hot Gas Control and Relay-Rinse and Hot Gas Control**).

The 'OFF' position (center) interrupts power to all control circuits, except the compressor circuit in remote condenser (R) models, and to the respective electrical operating components.

◆ **Warning:** All cuber circuits are not de-energized when this switch is in the 'OFF' position. **Disconnect power to the cuber before servicing.**

4. **Liquid Level Controller (LLC) and Water Level Probes:** A clear plastic tube, which contains three stainless steel probes and indicates the water level in the circulation system, is located at the front of all models. The high and low level probes sense the water shut-off level and harvest initiation level, respectively. The common probe serves as a reference for the high and low level probes since conductivity of low-voltage alternating current (AC) through the water provides the signals. The high level probe de-energizes the water fill circuit when contacted by water. The low level probe initiates harvest (during normal operation) or energizes the water fill circuit (start-up or cleaning cycles when the evaporator is warm) when the level of water is below this probe. Once the water fill has been completed and the water fill circuit has been de-energized, no further changes in the water fill or harvesting operation will be noted until the level is below the low level probe. The LLC input and outputs are line voltage. Note that both normally open (N.O.) and normally closed (N.C.) LLC connections are used. The blue circuit, which powers the harvest initiate and water fill circuits, is connected to common (COM). The black/green main power circuit is connected to the N.O. terminal to power the blue circuit whenever the LLC relay is energized, as during water fill and harvest initiation. The red "defrost" circuit is connected to the N.C. terminal as a fail-safe circuit to avoid water plate lockup in a partially-closed position.
5. **Pump and Defrost Switch:** The operation of each water pump is controlled by a pump and defrost switch which is actuated by a tab or bolt on the side of the water plate. The pump runs when the water plate is closed, and it stops as the water plate opens. With the water plate open enough so that the pump is not energized, the red circuit, which powers the water plate opening actuator motor winding, is energized. If this switch is not actuated to start the pump before the water plate is completely closed, the actuator motor will repeatedly re-open the water plate. If the water plate closing is obstructed by ice which did not fall off, the springs will stretch so that the cam may continue to rotate, but the water plate tab or bolt cannot actuate the pump and defrost switch and the water plate will re-open to clear the obstruction. This switch must be actuated to start the pump when the spring-end of the front cam is between the 10 and 11 O'clock position while rotating clockwise to close the water plate. If the water plate springs have weakened over time, the water plate will not pull up tightly against the front cam and the pump switch adjustment will be affected. Be sure that the springs are not stretched, then if adjustment is necessary it is made by bending the tab or adjusting the bolt on the water plate. Do not bend the switch lever, but be sure that the tab or bolt engages the switch lever as the water plate closes. The pump and defrost switch in all single evaporator models, and the Master (upper) pump and defrost switch in dual evaporator models manufactured between January, 1992 and March, 1996 is a two-pole switch. The second pole provides power to the water solenoid valve through the black-to-yellow actuator toggle switch circuit to rinse the water plate as it opens for harvest. Rinse will not begin until approximately the same time as the pump stops, and the water

Controls and Adjustments

solenoid valve will be de-energized as soon as the water plate is fully open **only during harvest cycles** when the actuator thermostat, described later, is switched cold.

Since March, 1996 all single- and dual-evaporator models employ **ONLY** single-pole pump and defrost switches, and water plate rinse begins immediately upon harvest initiation. See EB#96001 for details.

- 6. Actuator Thermostat:** All models are provided with an actuator thermostat which senses the evaporator temperature. During the freeze cycle the actuator thermostat switches cold (at approx. +26° F. in its coldest adjustment) to set up the electrical circuit for harvest, connecting the blue LLC output (COM), which is not energized until the water level is below the low water level probe, to the red circuit. No change in cuber operation will be evident at this time. After ice has harvested this thermostat switches warm, above 50° F., connecting the water plate closing and water fill circuits to the blue LLC output which is energized at that time. Setting the actuator thermostat warmer will keep the water plate open longer after the ice has dropped.

Note: At the full warm (CCW) adjustment the actuator thermostat is locked in the cold switch contact position and will not reset warm, to raise the water plate, regardless of evaporator temperature. This control should never be set warmer than necessary to insure that all ice is out of the evaporator(s) before the water plate(s) begin closing.

- 7. Cold Water Thermostat:** All models except GT330/GT340/GT350 series are provided with a cold water thermostat which senses the evaporator temperature along with the actuator thermostat. In self-contained models, (A) or (W) except dual evaporator models (before 9/96), this control connects the hot gas valve to the blue LLC output when it is switched cold or to the red circuit when it is switched warm. The red circuit is energized whenever the water plate is not fully closed, and the blue circuit is energized from harvest initiation until completion of the water fill. The hot gas valve will be energized throughout the harvest cycle and until the water plate is completely closed and thereafter only if the cold water thermostat trips cold during the water fill.

Remote condenser models (R), and all dual evaporator models **before September, 1996**, do not have a red circuit connection to the cold water thermostat, so that the hot gas valve may be de-energized when the water plate is not fully closed but only if the cold water thermostat has reset warm. This allows cycling of the water plate, for example to dump cleaning solutions, without energizing the hot gas valve which would cycle the compressor in remote condenser models (R) due to the low-side pump-down controller, described later.

Note: The calibrations of the cold water and actuator thermostats may overlap. When there is no red circuit connection to the cold water thermostat it is necessary to provide a hot gas valve latching circuit until the actuator thermostat switches warm to avoid the possibility of the hot gas valve being de-energized before the water plate begins closing. This circuit is provided by the hot gas control relay, or by the rinse and hot gas control relay in dual evaporator models (before 9/96), described later.

The cold water thermostat additionally, acts as a foolproof control in the event that the evaporator temperature decreases very rapidly during the water fill due to very cold supply water, or if the water fill rate is abnormally slow due to inadequate water supply or a restricted filter/strainer, etc. Refer to the **Cold Water Thermostat Cycle** in the **Sequence of Operation**

Controls and Adjustments

section for the description of the cold water thermostat function in this case.

The proper adjustment is usually fully cold (CW). When supply water is very cold, less than 50° F., and ice is being fully-formed (control stream goes over the dam) or when the ice is not cleared from the water plate surface by the rinse water due to water plate surface breakdown (also see **Water Plate Service** section), the cold water thermostat may be adjusted warmer (CCW). This will provide additional heat to the water, only during the fill cycle, to avoid progressive freezing-up of the water plate which will result in early failure. A warmer setting is recommended for remote condenser models (R) and all dual evaporator models with cold supply water.

- 8. Actuator Toggle Switch:** The travel of the actuator motor in all models is controlled by the actuator toggle switch, which is tripped by a paddle on the motor gearbox output shaft. When the water plate is fully closed, as during the freeze cycle, the switch lever is in the 'up' position. This connects the water plate opening winding of the motor to the red circuit, and also connects the water solenoid valve coil to the water plate rinse circuit. When the water plate is fully open, as during the harvest cycle, the switch lever is in the 'down' position. This connects the water plate closing winding of the actuator motor and the water solenoid valve coil to the warm actuator thermostat circuit, and also connects the red circuit to the black/green main power circuit which powers the fail-safe circuit, described under **Liquid Level Controller**.

The paddle which trips this switch may be bent slightly to insure that the water plate stops in its widest open position. This is necessary for proper harvest of half-cubes (HK). In dual evaporator models only, the paddle may be bent to provide slight overtravel, toward the 1 O'clock position (**not recommended with NEW STYLE Actuator Motors**), when the Master (Upper) water plate closes, for a slight additional synchronization time. See additional details under **Timer-Master Actuator Motor Delay**.

- 9. Capacitor(s)-Actuator Motor:** All actuator motors employ a capacitor between the two windings to determine the direction of rotation when the motor is energized.

Models manufactured between approximately 1964 and 5-1-95 employ the OLD STYLE actuator motor which requires a 1.5 mfd. capacitor for this purpose. These motors were all rated 115 Volts, and in 208-240 Volt applications, where an internal transformer was not employed to provide 115 Volts to the actuator motor, a second capacitor in series with the motor winding, white wire, was employed for voltage reduction. The value of the second capacitor was 1.5 mfd. for 220-240 Volt/50 Hz. models, or 2.0 mfd. for 208-230 Volt/60 Hz. models.

Models manufactured after 5-1-95 employ a NEW STYLE actuator motor which is rated either 115 Volts or 230 Volts and requires only one capacitor installed between the windings of each motor for direction of rotation. The 115 Volt motor capacitor is rated 4 mfd., and the 230 Volt motor capacitor is rated 1 mfd.

Replacement Actuator Motor kits after June, 1995 are provided with only the NEW STYLE actuator motors. Refer to the **Service and Troubleshooting** section to determine which style is installed and the respective troubleshooting information.

- 10. Contactor:** All models are provided with a contactor which carries the compressor load, and the fan motor load in air cooled models (A). The contactor coil is rated for line-voltage, and the contacts are rated for definite purpose applications (FLA and LRA).

Controls and Adjustments

11. **High Pressure Cutoff:** All models are provided with a high pressure cutoff controller in the compressor discharge line which opens the contactor coil circuit on high-side pressure rise to 400 (435 after December, 1995) psig. The controllers have been MANUAL RESET type since approximately 3-93.
12. **Pump-Down Controller:** All remote condenser models (R) are provided with a pump down controller in the compressor suction line which opens the contactor coil circuit when the low-side pressure decreases to 5 to 10 psig. The intent of this controller is only to pump the low-side down during off periods, but a shortage of refrigerant in the system will cause it to function during freeze cycles. See the **Installation Guidelines** for charging requirements for these models.
13. **Relay-Hot Gas Control:** (Single evaporator remote condenser (R) models, and **Relay 2 in Dual evaporator R models beginning in September, 1996**) This controller is shown in the ALTERNATE WIRING on the wiring diagrams. Its purpose is to isolate the hot gas valve circuit from the red circuit so that the hot gas valve is not energized any time the water plate is not fully closed unless the actuator or cold water thermostat is switched cold. This allows checking of the actuator motor operation and dumping of cleaning solutions without cycling the compressor due to the pump-down controller with the 'ICE-OFF-WASH' switch in the 'WASH' position. See **Cold Water Thermostat** for more details.
14. **Relay-Rinse and Hot Gas Control:** (All Dual evaporator models **before September, 1996**) This controller serves the same purpose as the hot gas control relay, see above. In addition, it serves to isolate the two actuator motor water plate closing winding circuits from each other and from the water plate rinse circuit to insure water plate synchronization. See **Timer-Master Actuator Motor Delay** description and **Service and Troubleshooting** section for more details.
15. **Relay-Water Plate Synchronization:** (All Dual evaporator models **beginning in September, 1996**) This relay is designated as **Relay 1**, and its purpose is to only allow the Slave actuator motor to be energized depending upon the position of the Master actuator motor/toggle switch for more reliable synchronization (see **EB #96003**).
16. **Timer-Master Actuator Motor Delay:** (Dual evaporator models, Upper only) This controller is only employed with NEW STYLE actuator motors, after 5-1-95. It delays the starting of the Master (Upper) actuator motor for 2 seconds in either direction during normal ice making operation. The Slave (Lower) actuator toggle switch must be tripped BEFORE the Master in order to properly synchronize the water plates. There is also an interconnection between the actuator motor circuits which stops the Slave motor in the water plate closed position until the Master motor completes closing its water plate. See the **Service and Troubleshooting** section for more details.

Sequence of Operation

- ◆ The following sequence begins with the cuber as shipped from the factory with the **Water Plate(s)** closed and ready to begin a normal ice making cycle.

WATER FILL CYCLE

After about a pint of clean water is added to each water tank (start-up only) with the **Bin Thermostat** warm, power is turned on by moving the '**ICE-OFF-WASH**' Switch to either '**ICE**' (left side) or '**WASH**' (right side) position to observe the water fill cycle. When the **Actuator Thermostat** is switched warm, **Evaporator** above +60° F., the **Water Solenoid Valve** will be energized only until the water level reaches the **High Water Level Probe**, and the **Water Pump** will run when the **Water Plate** is closed.

Note: If the **Actuator Thermostat** is switched cold (**Evaporator** temperature is lower than +26° F. or has not risen to above +60° F. after a harvest, or if the **Thermostat** is locked-out in its WARMEST adjustment) the **Water Plate** will begin to open as soon as power is applied, but the **Water Solenoid Valve** will not be energized until after the **Water Pump** stops as the **Water Plate** opens if the cuber has a double pole pump switch rinse circuit (see **Controls and Adjustments** section).

Remote Condenser Models (R) Only: The **Compressor** is connected directly to the line through the **High-Pressure Cutoff** and the **Pumpdown Controller**, so the **Compressor** may cycle with the '**ICE-OFF-WASH**' Switch in any position as soon as power is applied.

COLD WATER THERMOSTAT CYCLE (except GT33X/GT34X/GT35X)

With the refrigeration unit running ('**ICE-OFF-WASH**' Switch in the '**ICE**' position) the **Evaporator** will begin to cool as soon as power is applied. If the **Evaporator** temperature lowers to approximately 45° F. during the water fill cycle, the **Cold Water Thermostat** will switch cold and the **Hot Gas Valve** will be energized until the **Evaporator** temperature rises above 50° F. or until the water fill is completed, then refrigeration resumes.

Note: This is a normal function when the water supply temperature is lower than 50° F., however it may occur if the water fill rate is abnormally slow due to low water supply pressure, undersized water supply line, or restricted **Water Strainer** or external filter. With proper water supply characteristics the water fill should complete in approximately 1 minute for (K) cube or 1-1/2 minutes for (C) or (HK) cube size models.

FREEZE CYCLE

Once the water fill cycle has been completed, the **Water Solenoid Valve** will remain de-energized until during the following harvest cycle. The **Cold Water** and **Actuator Thermostats** switch to their cold contacts as the **Evaporator** temperature lowers to their settings, however no change in the cuber functions will be noted at these times. The water level in the **Liquid Level Probe Tube** lowers as the water is frozen, but no additional water will be introduced during the freeze cycle. The **Control Stream** runs continuously during the freeze cycle with the water returning to the **Water Tank** through the hole which can be seen through the **Control Stream Box** to the left of the **Dam** in the **Box**.

Note: No water, other than condensation, should drip or run to the **Drain Pan** from the **Control Stream** or from the **Water Tank** during the freeze cycle.

Sequence of Operation

CONTROL STREAM CYCLE

The water level in the **Liquid Level Probe Tube** must get below the level of the **Low Water Level Probe**, and both the **Cold Water** and **Actuator Thermostats** must have switched cold to initiate the harvest cycle. If there is an excess of water in the **Water Tank**, the **Water Pump** outlet pressure increases when the **Evaporator** cells are full, and the **Control Stream** rises and flows over the **Dam** to the **Drain Pan** to evacuate the **Liquid Level Control Tube**.

Note: The **Control Stream** is a "safety valve" to insure the ability to initiate harvest rather than an ice quality control, and it should never need to go over the **Dam** for more than 15 seconds before harvest begins. Setting the **Water Level Probes** so that the water in the **Liquid Level Control Tube** gets below the **Low Water Level Probe** to initiate harvest without the **Control Stream** running over the **Dam**, leaving a small "dimple" in the cubes, will result in increased ice making capacity and longer **Water Plate** life.

HARVEST INITIATION

When the water level in the **Liquid Level Probe Tube** is below the **Low Water Level Probe** and the **Cold Water** and **Actuator Thermostats** are switched cold, the **Liquid Level Control** output energizes the blue circuit at the COM terminal. Power is provided to the **Hot Gas Valve** through the **Cold Water Thermostat**, and to the **Water Plate** opening winding of the **Actuator Motor** through the **Actuator Thermostat** and the **Actuator Toggle Switch**. The **Evaporator** begins to defrost, and the **Water Plate** begins to open immediately while the **Water Pump** continues to run for a few seconds. The **Water Solenoid Valve** is not energized until approximately the same time the **Water Pump** stops when the **Water Plate** is slightly open and the **Pump and Defrost Switch Lift Tab/Bolt** on the side of the **Water Plate** allows the **Switch** lever to drop if the cuber has a double pole pump switch rinse circuit (see **Controls and Adjustments** section). The **Water Plate** rinse is terminated when the **Actuator Toggle Switch** is tripped DOWN in the **Water Plate OPEN** position (see wiring diagrams for full rinse option).

Note: Dual evaporator models require that the Slave (lower) **Actuator Toggle Switch** be tripped before the Master (upper) in both **Actuator Motor** directions to insure synchronization. This was accomplished by using a slower motor in the Master until 5-1-95, and by a **Delay Timer** in the Master motor circuit thereafter. The three-pole **Rinse and Hot Gas Control Relay**, or the **Water Plate Synchronization Relay in retrofitted per EB #96003 or 9/96 and newer models**, isolates the closing windings of the **Actuator Motors** from each other. This prevents the Slave **Water Plate** from beginning to close while the Master **Water Plate** finishes opening in the harvest cycle, when the **Actuator Thermostat** is cold, due to the power in the rinse circuit until the Master is fully open.

HARVEST CYCLE

As long as the **Actuator Thermostat** remains cold, the **Water Plate(s)** remain in the open position with the **Water Solenoid Valve(s)** de-energized. The **Hot Gas Valve** remains energized, and the **Evaporator(s)** become warm enough to release the ice which drops by gravity into the ice storage area.

Sequence of Operation

HARVEST TERMINATION

After the ice is out and the **Evaporator(s)** warm to the reset temperature of the **Actuator Thermostat**, up to +60° F., the **Actuator Motor(s)** will be energized to close the **Water Plate(s)**, and the **Water Solenoid Valve(s)** will be energized to begin the water fill for the next ice-making cycle. The **Hot Gas Valve** always remains energized until the **Water Plate** is fully closed in all self-contained (A) and (W) models except dual evaporator models **prior to 9/96 which have not been retrofitted per EB #96003**.

Note: The **Hot Gas Control Relay** in remote condenser (R) models, or the **Rinse and Hot Gas Control Relay** in all **pre-9/96** dual evaporator models, allows the **Hot Gas Valve** to be de-energized as soon as the **Cold Water Thermostat** switches warm, above +50° F., even before the **Water Plate(s)** is (are) fully closed, but only after the **Actuator Thermostat** switches warm and the **Water Plate(s)** begin closing.

PUMP START

As the **Water Plate** closes, the **Lift Tab/Bolt** on the **Water Plate** must raise the **Pump and Defrost Switch** lever to start the **Water Pump** before the **Water Plate** is fully closed. The **Tab/Bolt** should be adjusted so that the **Pump** starts when the **Cam** is between 10 and 11 O'clock.

Note: in dual evaporator models, the Slave (lower) **Water Plate** is ahead of the Master (upper) **Water Plate** so that the Slave **Pump** should start before the Master **Pump** starts.

CONTINUATION-NORMAL

When the **Cam** is at the 12 O'clock position, the **Paddle** on the **Actuator Motor** output shaft will trip the **Actuator Toggle Switch** up. If the **Water Plate** has completely closed and the **Water Pump** has started, the **Actuator Motor** will stop with the **Water Plate** closed and the cycle will repeat beginning with **WATER FILL CYCLE**.

Note: Since the Slave (lower) **Water Plate** is ahead of the Master (upper) **Water Plate** it will be fully closed and trip its **Actuator Toggle Switch** before the Master **Water Plate** is fully closed. An interconnection between the **Actuator Motors** causes the Slave to **stop** until the Master completes closing and trips its **Actuator Toggle Switch**. See **Actuator Motor** in **Service and Troubleshooting** section for circuit explanations.

ABNORMAL-WATER PLATE RE-OPENS

If the **Pump and Defrost Switch** is not properly actuated, due to mis-adjustment, weak springs, or an obstruction to the **Water Plate** travel, such as ice which did not slide off of the plate, the **Actuator Motor** will immediately reverse and re-open the **Water Plate**.

Additionally, if the cuber has a double pole pump switch rinse circuit (see **Controls and Adjustments** section and EB #96001) should the **Water Pump** start but the rinse pole of the **Pump and Defrost Switch** not break, either due to mis-adjustment or to a defective switch, before the **Actuator Toggle Switch** is tripped, the **Water Plate** will remain closed until the water fill is completed and then re-open as soon as water touches the **High Water Level Probe**.

Sequence of Operation

SHUTDOWN-BIN FULL

When the level of ice reaches the **Bin Thermostat** capillary tube, the ice maker stops automatically, and it remains off until the **Bin Thermostat** warms up when the ice level is lowered.

Note: In remote condenser models (R), the Compressor continues to run after **Bin Thermostat** shutdown until the low-side is pumped down to the setting of the **Pumpdown Controller**. This pressure should be between 5 and 10 psig and must never be vacuum.

SHUTDOWN-HIGH PRESSURE

All models are provided with a **High Pressure Cutoff** which interrupts power only to the **Compressor**, and to the **Condenser Fan Motor** in air cooled (A) models, when the high-side pressure rises to the cutoff setting. The **High Pressure Cutoff** requires manual resetting to restore power in all models manufactured after 3-93.

SHUTDOWN-HIGH TEMPERATURE

If the suction line temperature near the **Compressor** should rise to 130° F in cubers equipped with a **High Temperature Shutoff Thermostat** (see **Controls and Adjustments** section), power will be shut off to all operating components of the cuber. This control will automatically reset when the suction line cools to 110° F.

'WASH' CYCLE

All of the cuber's operational components except refrigeration are able to function with the **'ICE-OFF-WASH' Switch** in the **'WASH'** position. Simply placing this **Switch** in the **'WASH'** position does not complete the cleaning and sanitizing of the cuber. The instructions for cleaning are on a label inside the front cabinet panel of the cuber, in the **Preventative Maintenance** section of this manual, and in the cuber instructions.

Note: The frequency of the need for cleaning is determined by the supply water characteristics. The cuber should be cleaned no less frequently than once each 6 months, and it may require more frequent cleaning. The requirement for sanitizing frequency may be contained in local health code regulations.

Service and Troubleshooting

ACTUATOR MOTOR - DESCRIPTION & TEST PROCEDURE:

The actuator motor is a P.S.C. type with two windings in the coil and three power leads. The white wire is common to both windings, and the colored wires are connected to the actuator toggle switch and to a small capacitor. Power is supplied to one winding at a time by the actuator toggle switch, and the capacitor changes the voltage and phase to the other winding to determine the direction of motor rotation. Dual evaporator models are provided with an extra circuit for synchronization of the motors which will be described later.

Note: There are two different types of actuator motors since May, 1995. The OLD STYLE motor has an end cover which completely covers the windings, and an external drift stop is required. The NEW STYLE motor does not require the external drift stop, and the coil windings are visible.

All OLD STYLE motors are rated 115 volts, and a second capacitor, in series with the common winding lead (white wire), is provided in 208-230 volt/60 hz. (2.0 mfd/240 Vac) and 220-240 volt/50 hz. (1.5 mfd/240 Vac) to reduce line voltage to the motor **in 1992 and later models which do not have an internal transformer for this purpose.** The colored wires are always gray and yellow, and the direction capacitor is always 1.5 mfd/240 Vac.

The NEW STYLE (since May, 1995) motors are rated for 115 or for 230 volts and **never** require two capacitors.

The 115 volt NEW STYLE motor colored wires are black and yellow, and the reversing capacitor is 4.0 mfd/250 (or greater) Vac.

The 230 volt (50/60 hertz) NEW STYLE motor colored wires are red and yellow, and the reversing capacitor is 1.0 mfd/370 (or greater) Vac.

Only the NEW STYLE actuator motors will be available after June, 1995. Replacement of OLD STYLE with NEW STYLE actuator motors requires adaptation provided with kits for the various applications. Refer to the application list following this text for identification of the kits and wiring instructions.

CAUTION: Do not remove the outboard rotor bearings from any NEW STYLE motor. Replacement motor parts (coil, rotor, etc.) are not available, and removal of the bearing may cause damage.

Both OLD STYLE and NEW STYLE actuator motors should produce enough output torque so that it is difficult to stall the cam with your finger. If not, the self-aligning bearings may have been jarred out of alignment. Tap on the gearbox with a small hammer or equivalent while the motor is running in both directions to re-align the bearings. It is good practice to do this on every new installation, or with any motor replacement, to correct for mis-alignment due to shipping or handling.

OLD STYLE motors are impedance protected to prevent unsafe overheating. These motors will get very hot in the event of a stalled condition or in continuous operation (such as pump switch mis-adjustment with water plate continuously opening and closing), however power to the coil windings is not interrupted by a protective device.

NEW STYLE motors are provided with a thermal protector in the windings which will interrupt power if its trip temperature is reached. If a NEW STYLE motor is hot and not running, wait for the motor to cool enough to reset the protector before performing any motor/capacitor tests.

If either type motor runs continuously, repeatedly tripping the actuator toggle switch, but the water plate does not move, a cam pin is broken or missing.

Proper cam travel, viewing the water plate spring connection, is as follows:

- ▶ Water plate closed, cam stopped at noon position with actuator toggle switch lever in the 'up' position.

Service and Troubleshooting

- ▶ Water plate opening, cam rotates counter-clockwise from noon to 7 O'clock position with the actuator toggle switch lever in the 'up' position.
- ▶ Water plate fully open, cam stopped at 7 O'clock position with actuator toggle switch lever in the 'down' position.
- ▶ Water plate closing, cam rotates clockwise from 7 O'clock position to noon position with the actuator toggle switch lever in the 'down' position.

Dual Evaporator Models Only

Dual evaporator cubers are provided with Master (upper) and Slave (lower) ice making sections which must be synchronized for proper operation. In order to synchronize the water plates without repeated opening and closing, the Slave actuator switch **must** be tripped ahead of the Master actuator switch in both opening and closing the water plates. The method to accomplish this is different between OLD STYLE and NEW STYLE actuators motors, and **changes with NEW STYLE motors occurred in September, 1996**. The proper wiring diagram **must** be used when troubleshooting.

CAUTION: Both actuator motors must be the same type - OLD STYLE or NEW STYLE.

OLD STYLE Actuator Motors (Original in GB1224 and GB1225 Models only):

The Master (upper) motor is provided with a special rotor to produce a slower output speed than the Slave (lower) motor. The special rotor is identified by an orange dot on the outboard endplate of the rotor laminations.

If the Slave unit is not approximately 4 to 10 seconds ahead of the Master in both directions:

- ✓ Tap the gearboxes to be sure that the bearings are aligned
- ✓ Check the drift stop tightness (only very slight pressure between the plastic button and the end of the rotor shaft is needed)
- ✓ Be sure that the Master motor has the special rotor
- ✓ Eliminate binding in the cam shaft bearing brackets and/or water plate springs (excessive front bearing bracket shimming will cause binding)
- ✓ Check the voltage across the motor direction capacitor per the following table if necessary.

If all of these items check out the problem is in the gearbox, and motor replacement will be required.

NEW STYLE Actuator Motors:

The Master (upper) and Slave (lower) motors are identical and should run at the same speed. A timer is provided in the Master motor circuit to delay the start of this motor for approximately 2 seconds, giving the Slave a head start toward tripping its actuator switch.

If the Slave actuator switch is not tripped before the Master, first be sure that the Master time delay is working, then:

- ✓ Tap the gearboxes to be sure that the bearings are aligned
- ✓ Eliminate binding in the cam shaft bearing brackets and/or water plate springs
- ✓ Check the voltage across the motor direction capacitor per the following table if necessary.

If these items check out and the Master motor runs faster than the Slave so that it overcomes the delay time and trips its switch ahead of the Slave, swap the motors.

Do not disassemble either motor.

Service and Troubleshooting

All Actuator Motors (Dual Evaporator Models):

In opening the water plates for harvest with the actuator thermostat switched *cold* there is no power in the water plate closing circuit, so the water plates will both stop in the fully-open position. However, if the Master (upper) actuator switch is tripped first (see above) the Slave (lower) may stop before its switch is tripped. If so, after harvest the Master will close but the Slave will remain open until the Master closes completely and trips its switch. Then the Master will re-open and the Slave will finish opening then close (pre-9/96), stopping when fully-closed until the Master re-closes. This results in wasted cycle time, and the Slave will be overfilled with water, but no damage is caused.

In normal harvest operation, both water plates open fully and both actuator switches are tripped to the 'down' position until the actuator thermostat switches *warm*. Then both water plates begin closing (Master begins closing after time delay with NEW STYLE motors), the Slave actuator switch is tripped 'up' and the Slave motor stops until the Master finishes closing. Both water plates should remain fully closed until the next ice harvest. If not, there may be an obstruction (ice stuck on water plate), or a pump switch may be out of adjustment.

Slave Motor Stopping Circuit:

The Slave (lower) motor stopping circuit **before September, 1996** is the black wire from the Slave actuator switch to the yellow Master (upper) actuator motor winding wire. In normal operation, this circuit functions only during the time required to finish closing the Master water plate after the Slave is fully closed. However it can also stall the Slave motor abnormally, as described above, if the Master actuator switch is tripped first in the water plate opening sequence. Following is the circuit rationale:

In the normal harvest cycle water plate opening sequence with the actuator thermostat switched *cold*, Relay 1 (Rinse and Hot Gas Control Relay) coil is not energized. The yellow/orange circuit which powers this coil from the actuator thermostat *warm* contact also supplies power through the normally open (N.O.) contacts to the yellow and orange Master and Slave, respectively, actuator switches for closing the water plates. Therefore both water plates stop fully open for harvest unless there is a fault. The red circuit, which powers the actuator motors in water plate opening, is initially energized by the LLC (liquid level control) output through the *cold* actuator thermostat. This circuit may also be energized by either pump and defrost switch (to re-open the water plates in the event of an obstruction, or to dump cleaning solution), and it is kept energized through either or both actuator switches in the 'down' position.

When the Slave actuator switch is tripped 'up' with its water plate fully closed, the red circuit is still energized from the Master actuator switch which has not yet been tripped 'up'. The Slave motor is now being powered in the opening direction, but the closing direction winding is also being powered by the black wire circuit from the yellow Master motor to the Slave actuator switch. With both windings powered from the line, the motor "stalls" in electrical equilibrium.

Note: During water plate opening with the actuator thermostat switched *warm*, such as when dumping cleaning solution or re-opening due to an obstruction, neither water plate should stop in the fully-open position. With NEW STYLE actuator motors the time delay in closing is canceled, but the Slave water plate should begin closing before the Master completes opening so that the closing delay is not needed for synchronization.

Beginning in September, 1996 Relay 1 is designated as the SYNCHRONIZATION RELAY, and Relay 2 (HOT GAS CONTROL RELAY) is added ONLY IN REMOTE CONDENSER MODELS as in all single evaporator remote models. Relay 1 prevents the Slave actuator motor from closing its water plate before the Master water plate is fully open, and from opening or re-opening its water plate before the Master water plate is fully closed by **preventing it from being energized** before the Master

Service and Troubleshooting

actuator switch has been tripped to its respective position **regardless of evaporator temperature. The time delay always occurs before the Master plate begins closing**, but not upon re-opening due to an obstruction, etc.).

Between late-1995 and September, 1996 a field-installed circuit modification kit was available on an experimental basis. This kit included an additional relay, RELAY 2, and re-wiring of the actuator motor interconnecting circuit. **This Relay 2 is different from the September, 1996 changes.** No further information regarding this modification is published in this manual. Contact the factory if you have any questions.

Kits are available to retrofit older models to the September, 1996 circuits. Refer to EB #96003 for details.

Actuator Motor Electrical Tests

The following tests are for troubleshooting the actuator motor and related circuits: Use an AC voltmeter set for proper range. Voltages in the tables are measured across the motor reversing capacitor (between the colored motor lead wires).

> If there is no ice in the evaporator(s) and the water plate(s) is (are) not fully closed with the pump(s) running AND the actuator switch(es) tripped UP, the actuator motor(s) should be running. If not, be sure that there is power to the motor(s) and that it (they) is (are) not off due to high temperature (NEW STYLE). **Always refer to the proper wiring diagram when troubleshooting.**

> In dual evaporator models if only one motor appears to be running as it should, be sure that you understand the synchronization circuit (see text).

> For OLD STYLE motors in 208-230/60 or 220-240/50 *CLASSIC* cubers, the voltage between the white motor lead (connected to the voltage reduction capacitor) and the colored lead (gray or yellow) being powered by the actuator switch must be 90 to 130 volts. This varies with line voltage, and if not within these limits the motor(s) may not provide adequate performance. Be sure that the proper capacitor is installed (see text).

> Motor winding resistance's at 75° F out of the circuit are as follows:

All OLD STYLE motors, white to gray or yellow, approximately 450 ohms.

NEW STYLE 115 volt motors, white to black or yellow, approximately 95 ohms.

NEW STYLE 230 volt motors, white to red or yellow, approximately 400 ohms.

Actuator Motor Style	<u>Voltages for test table below</u>	
	<u>"A"</u>	<u>"B"</u>
OLD STYLE, ALL	180-240	90-130

Voltage Reading	Capacitor	Motor	Remedy
"A" from table	Good	Good	Tap gearcase to align bearings; check cam shaft for binding; check drift stop tightness. Change motor if all OK.
"B" from table	Open	Good	Change capacitor.
"B" from table in one actuator switch position. 0 v. in the other position	Open AND>	One Motor Winding open	Change both motor and capacitor.
"A" from table in one actuator switch position. 0 v. in the other position	Good	One Motor Winding open	Change motor.
0 v. in both positions EXCEPT DUAL EVAP. SLAVE DURING NORMAL STALL. Be sure there is power to the motor ("B" from table) by leaving one probe on either capacitor lead and placing the other probe on the white motor lead. If power is OK:	Shorted OR>	Both Motor Windings open	Disconnect motor from circuit and test winding resistance's (see text). If normal, change the capacitor, and if erratic change the motor.

Service and Troubleshooting

"New" 230 V. Actuator Motor Capacitor Styles

There has been a greater than normal number of failures of the actuator motor reversing **capacitors** employed with **NEW STYLE 230 volt** actuator motors in **dual evaporator cubers**. Although this style of capacitor is very convenient, with integral mounting tab and quick-connect terminals, the dual-evaporator cuber application requires a more durable capacitor.

Beginning with production dual evaporator cubers approximately December 1, 1995, followed by 102 1238 02 motor kits and 102 1241 02 replacement capacitor kits, the style of the actuator motor reversing capacitor was changed to an **oval tubular capacitor**. It has un-insulated axial lead wires and is mounted with a cable tie in place of the original style capacitor. Replacement capacitors will be mounted with the same mounting screw as the original capacitors, and insulation tubing will be provided to insulate the lead wires. The different styles are illustrated below.

Note: This change was never made in factory-production single evaporator cubers. Beginning in September, 1996, a more robust capacitor with terminals (similar to "OLD STYLE" as shown below) was employed in **ALL** models with **NEW STYLE 230 volt** actuator motors until Feb., 2001 when the tubular capacitor ("NEW STYLE" as shown below) was re-instated in all dual evaporator cubers, as well as 102 1241 02 replacement capacitor and 102 1238 02 230 volt motor kits.

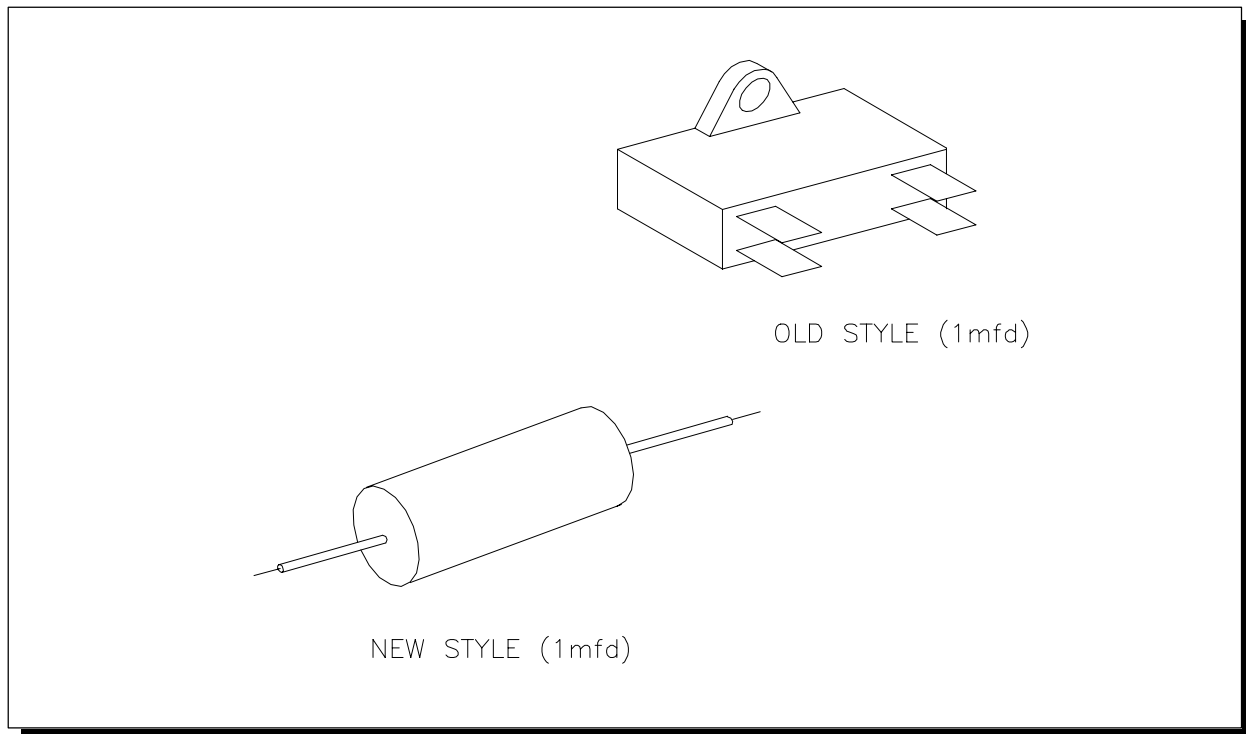

Actuator Motor Reversing Capacitor Styles for NEW STYLE 230 Volt Actuator Motors

Following are the instructions provided with replacement actuator motor kits for replacing OLD STYLE with NEW STYLE actuator motors. Note that only the OLD STYLE capacitor is shown in the illustrations.

Service and Troubleshooting

Actuator Motor Replacement Instructions for 102 1238 01 115 V.-60 Hz. or 102 1238 02 230 V.-50/60 Hz. Replacement Kit

This kit contains components for field replacement of **old style** (prior to May, 1995) actuator motors in all **Kold-Draft®** cubers.

Additional items may be required to complete installation in some models. Refer to the chart on the last page for additional application information.

CAUTION:

- ◆ RISK OF PERSONAL INJURY, PROPERTY DAMAGE, EQUIPMENT FAILURE OR FIRE.
- ◆ Refer all maintenance to qualified personnel.
- ◆ Disconnect power before servicing equipment.
- ◆ Read all instructions and understand your particular model requirements before proceeding.

Reference Key

Classic: GB421, GB634, GB1224, GT331, etc...,

Electronic: GB7-E, GB401, GB603, GB1204, GT301, etc...,

Electromechanical: GB2, GB4, GB7, GT1, GS6, GY3, etc...,

Old motor removal

1. Remove the roll pin or front cam pin to release the actuator motor from the cam. Lower the water plate.
2. Disconnect the motor and capacitor wiring. *Note:* if the wire connectors cannot be removed, cut the wires as close to the connectors as possible.
3. Remove the actuator motor and capacitor(s) from unit.
 - ◆ **Electronic** only: The P.C. card and insulation board must be moved out of the way, before the actuator motor and C-R-C network can be removed. Disconnect the actuator toggle switch from the C-R-C network.
 - ◆ **Electromechanical** only: Separate the motor conduit from the conduit fitting on the front channel. This can be done by pulling on the conduit. *Note:* The conduit fitting on the channel will be used for connecting the replacement motor.
4. If the actuator toggle switch is mounted on the motor, remove the switch from the switch mounting bracket.

Service and Troubleshooting

New motor installation

Classic and Electronic only

1. On these models, the switch is mounted on the motor for actuation by the paddle. Attach the paddle to the actuator shaft using the 1/8" dia. x 3/8" long roll pin provided. *Note:* GT **Classic** installations require a different paddle mounting position than the GB **Classic**/GB-GT **Electronic**. (See Illustration "A")
2. Attach Q.C. terminals to the motor wires as shown (OLD STYLE capacitor only).
3. Position the actuator toggle switch in the new switch support and secure with the

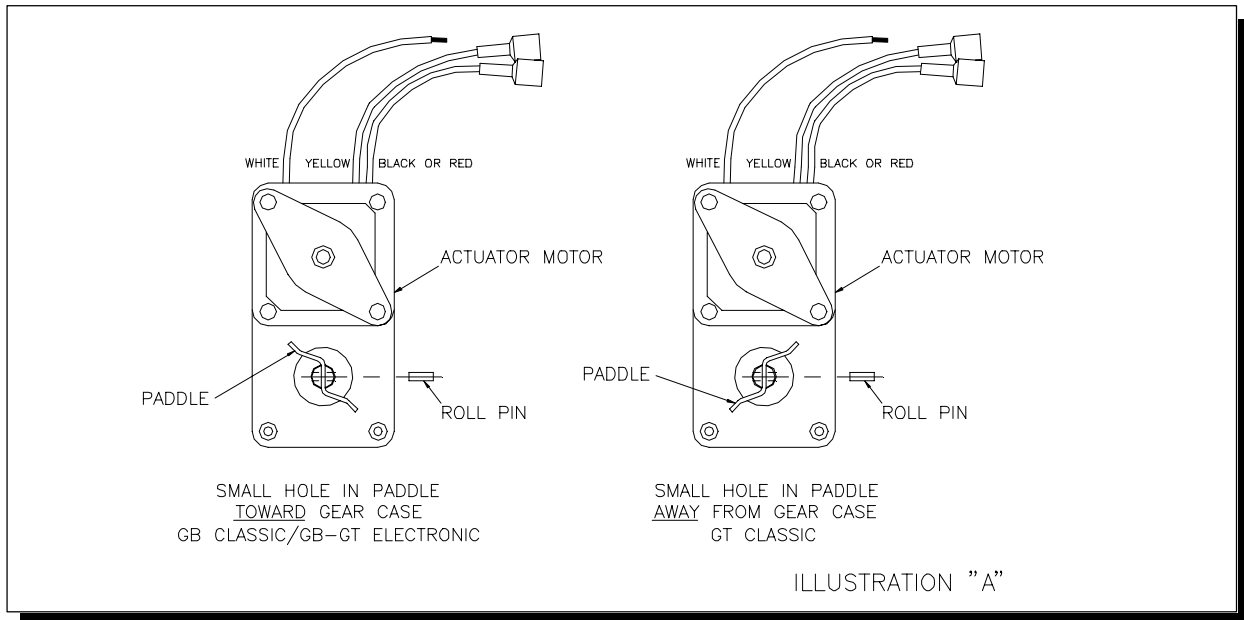

switch nut.

4. Mount the switch support and the motor mounting bracket to the motor, with (2) #8-32 x 3/8" screws. (See Illustration "B")

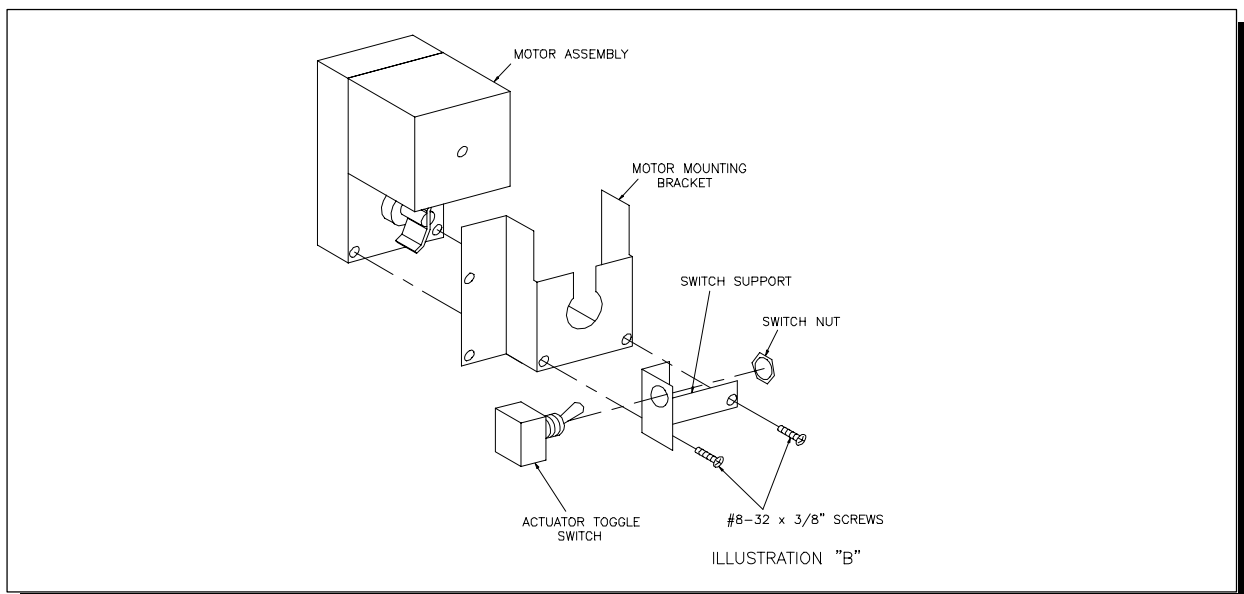

Service and Troubleshooting

5. Attach slip-on terminals to actuator toggle switch wires (OLD STYLE capacitor only).
6. Install the motor/switch assembly in the cuber electrical box. Place the motor shaft through the hole in back of the box, and into the cam hole or shaft extension hole. Align the motor bracket flange holes with the holes in the electrical box, and attach.
 - ◆ For the **Classic** installation, use (2) #8-32 x 3/8" screws and locking nuts. (See Illustration "C"--OLD STYLE capacitor shown)

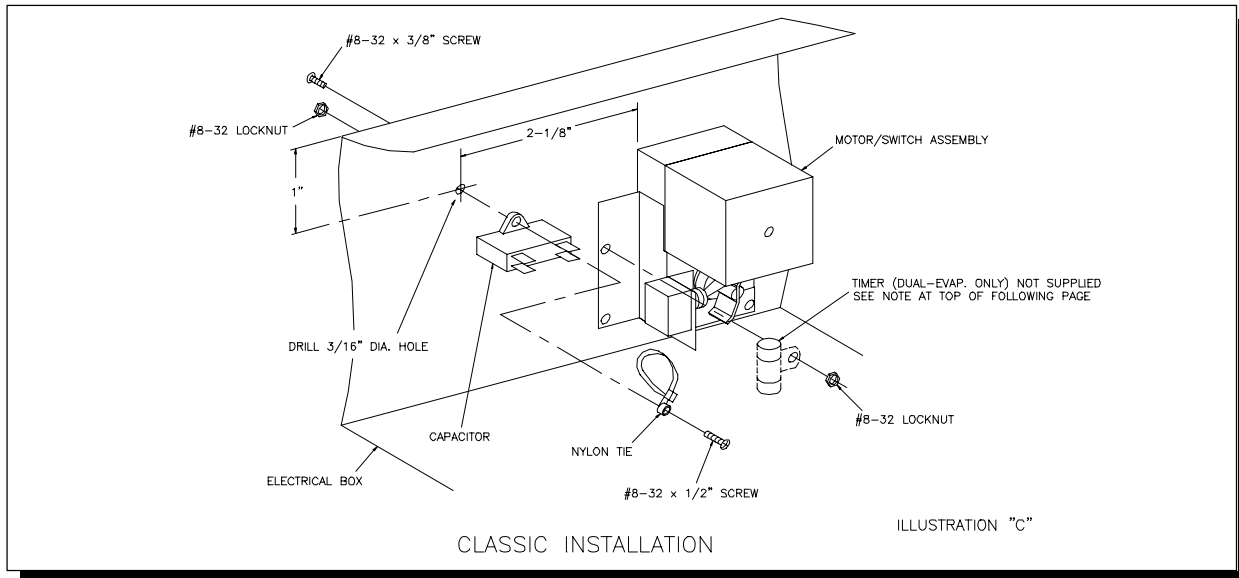

- ◆ In some **Classic** applications, the water pump ground wire was connected to a screw on the old actuator motor. It must be moved to a water valve screw. **Do not loosen any screws on the new actuator motor.**
- ◆ For the **Electronic** installation, use (2) #8-32 x 1/4" screws. (See Illustration "D"--OLD STYLE capacitor shown)

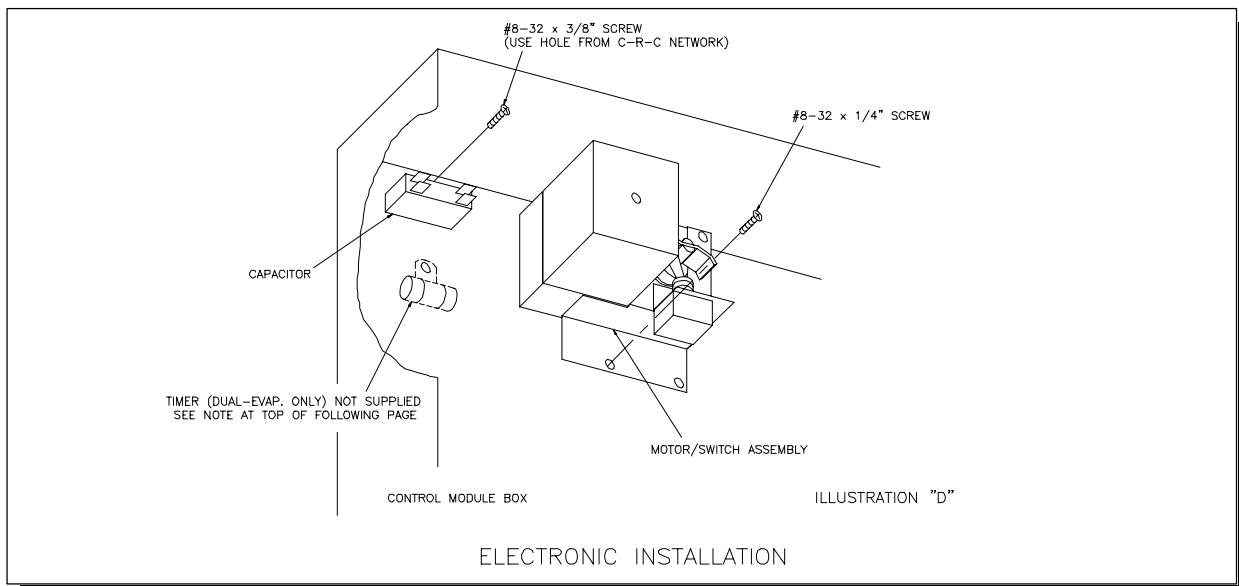

Service and Troubleshooting

Note: Illustrations "C" and "D" show locations for mounting the delay timer required for **new** motor use in dual evaporator ice makers. This timer is supplied as a separate kit and is only used with the master (upper) motor. Refer to the application chart following these instructions for additional application information.

7. Position the front cam and install the roll pin or front cam pin.
8. Install the capacitor in the cuber electrical box, and make wiring connections.
 - ◆ For the **Classic** installation, locate and drill a 3/16" dia. hole as shown in Illustration "C". Attach the capacitor and nylon tie with a #8-32 x 1/2" long screw and lock nut. (See Illustration "C")
 - ◆ For the **Electronic** installation, attach the capacitor to the module box with a #8-32 x 3/8" long screw. Use the existing threaded hole from the C-R-C network. (See Illustration "D") Install insulation tubing over the R-C network leads and connect between the white motor lead and the yellow motor lead. Use the two closed end connectors provided.

Note: See Illustration "F" for wiring details (OLD STYLE capacitor shown).

Electromechanical only

Installation on **Electromechanical** models will require a motor cover. This cover is supplied as a separate kit. Refer to the chart on the last page for additional application information.

1. Assemble the actuator motor, motor mounting bracket and motor cover. Feed the motor wires through the conduit of the cover assembly, and fasten the components with (4) #8-32 x 3/8" long screws. (See Illustration "E")

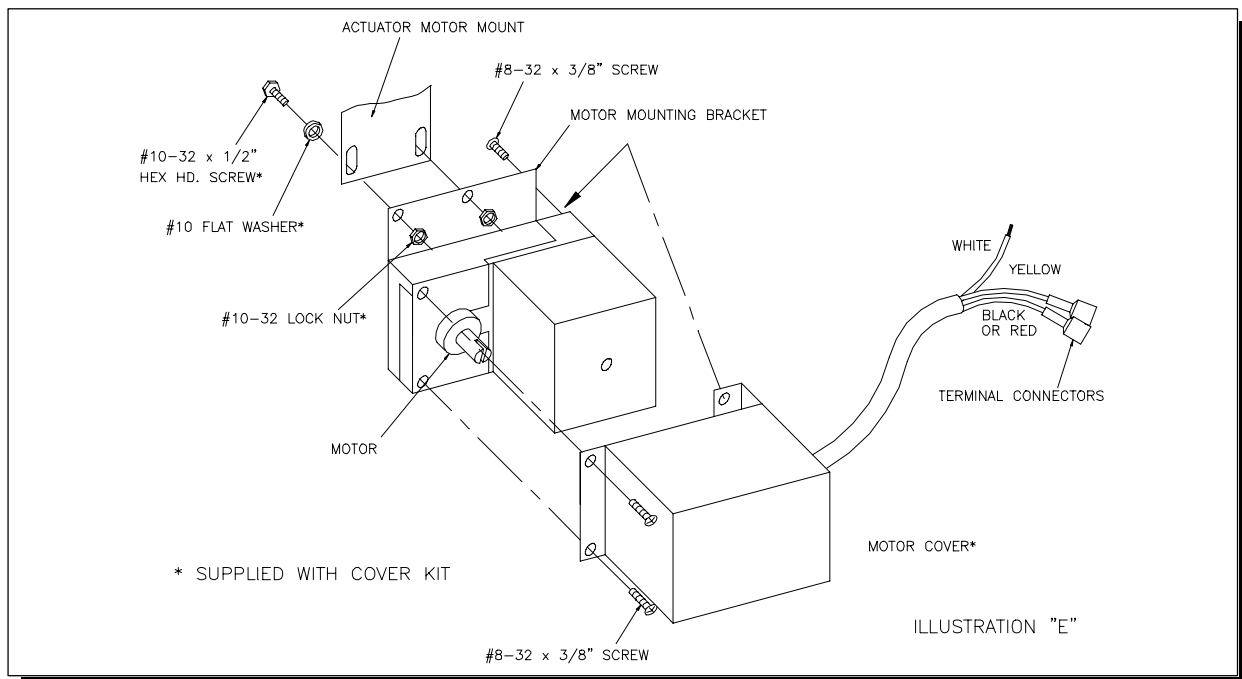

2. Feed the actuator motor wires through the conduit fitting on the front channel, and thread the conduit onto the fitting by turning the motor assembly clockwise.
3. Attach Q.C. terminals to the motor wires. (See Ill. "E"--OLD STYLE capacitors).

Service and Troubleshooting

4. Position the motor/cover assembly, placing the motor shaft into the cam hole. Align the motor bracket flange holes with the actuator motor mount holes and attach using (2) #10-32 x 1/2" hex head screws, (2) #10 flat washers and (2) #10-32 lock nuts. (See Illustration "E")
 5. Position the front cam and install the front cam pin.
 6. Attach Q.C. terminals to the gray and yellow actuator switch wires.
 7. The capacitor should be located in the front channel, so that the motor and switch wires can be connected to it. (See Illustration "F" for wiring schematic)
- Note:** A delay timer is required for **new** motor use in dual evaporator ice makers. This timer is supplied as a separate kit and is only used with the master (upper) motor. Refer to the chart on the last page for additional application information.

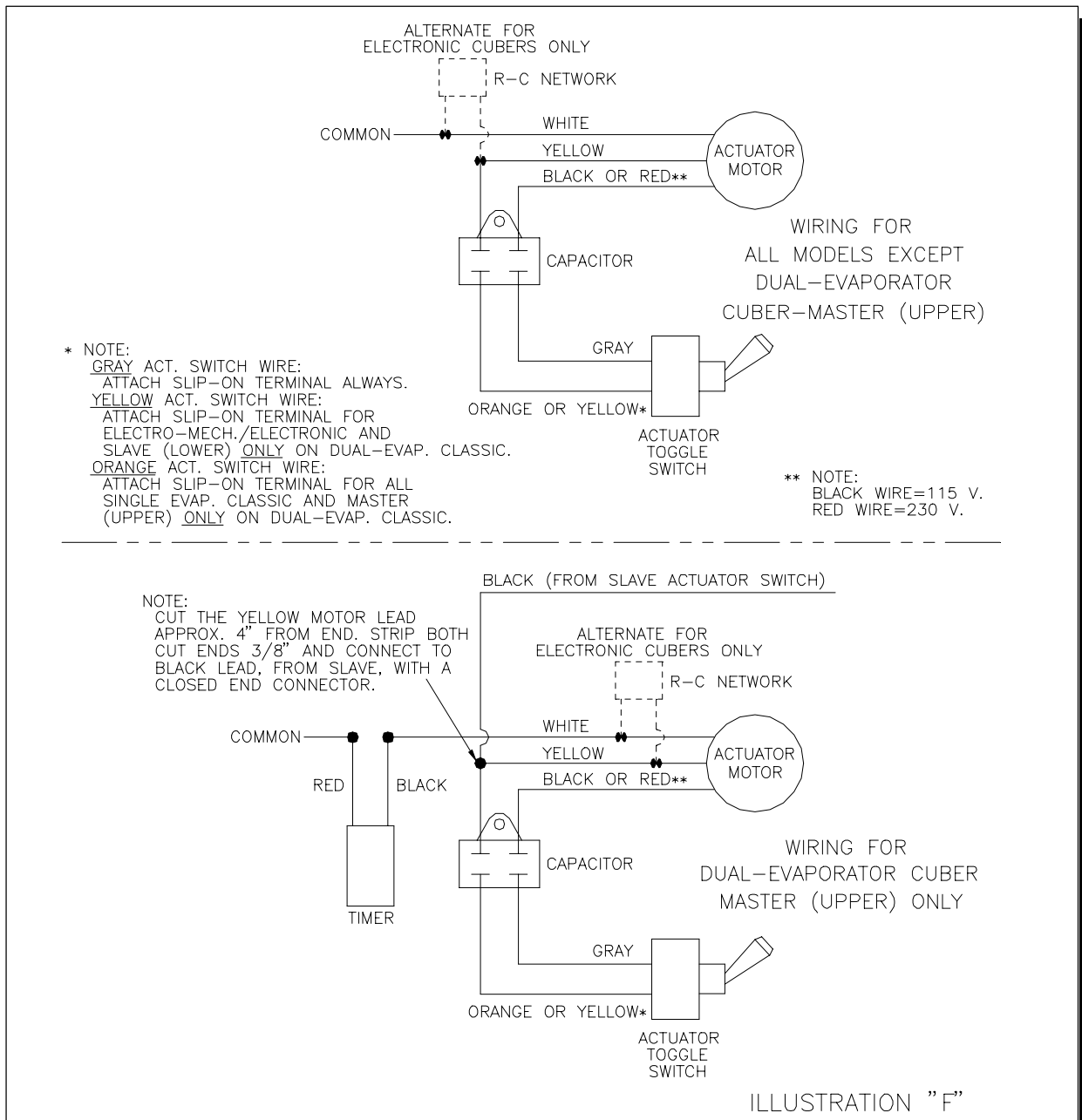

ACTUATOR MOTOR KIT APPLICATION LIST

Model No.	102 1292 01 115V. 60HZ.	102 1292 02 208/240V. 50/60HZ.	102 1238 01 115V. 60HZ.	102 1238 02 208/240V. 50/60HZ.	102 1239 01 115V. Timer Kit	102 1239 02 208/230V. Timer Kit	102 1240 01 Motor Cover Kit
Classic							
GB421, GB431, GB441, GB451, GT551							
GB427, GB434, GB437, GB444, GB447, GB454, GB457, GB624, GB627, GB634, GB637, GB644, GB647, GB654, GB657, GT554, GT557							
GB1224, GB1225, GB1244, GB1245, GB1254, GB1255, GB1257, GB1258		2-Required					
GT331, GT341, GT351							
GT334, GT337, GT344, GT347, GT354, GT357							
Electronic							
GB401, GB402, GB406, GB503, GB603, GT301, GT306, GT401, GT402, GT406, GT503, GT603, IS401, IS503							
GB903, GB1003, GB1204, GB1205			2-Required				
GB407, GB507, GT307, GT407, GT507, IS507							
GB1208				2-Required			
Electro-mechanical							
GB1, GB2, GB5, GB7, GS6, GT1, GT7, GT8, GY3, IS1, IS5, IS7, MD1, MD5							
GB4			2-Required				2-Required
GB1F, GB7F, GS6F, GT1F, GT7F, GY3F, IS7F							
Other							
T175 crusher, TKN2 agitator, AKD agitator							

Service and Troubleshooting

WATER PLATE

Too little ice web thickness (spacing between the evaporator and the water plate) or incorrect alignment of the water plate and evaporator may cause icing of injection and return holes on the water plate surface. Refer to water plate alignment drawing.

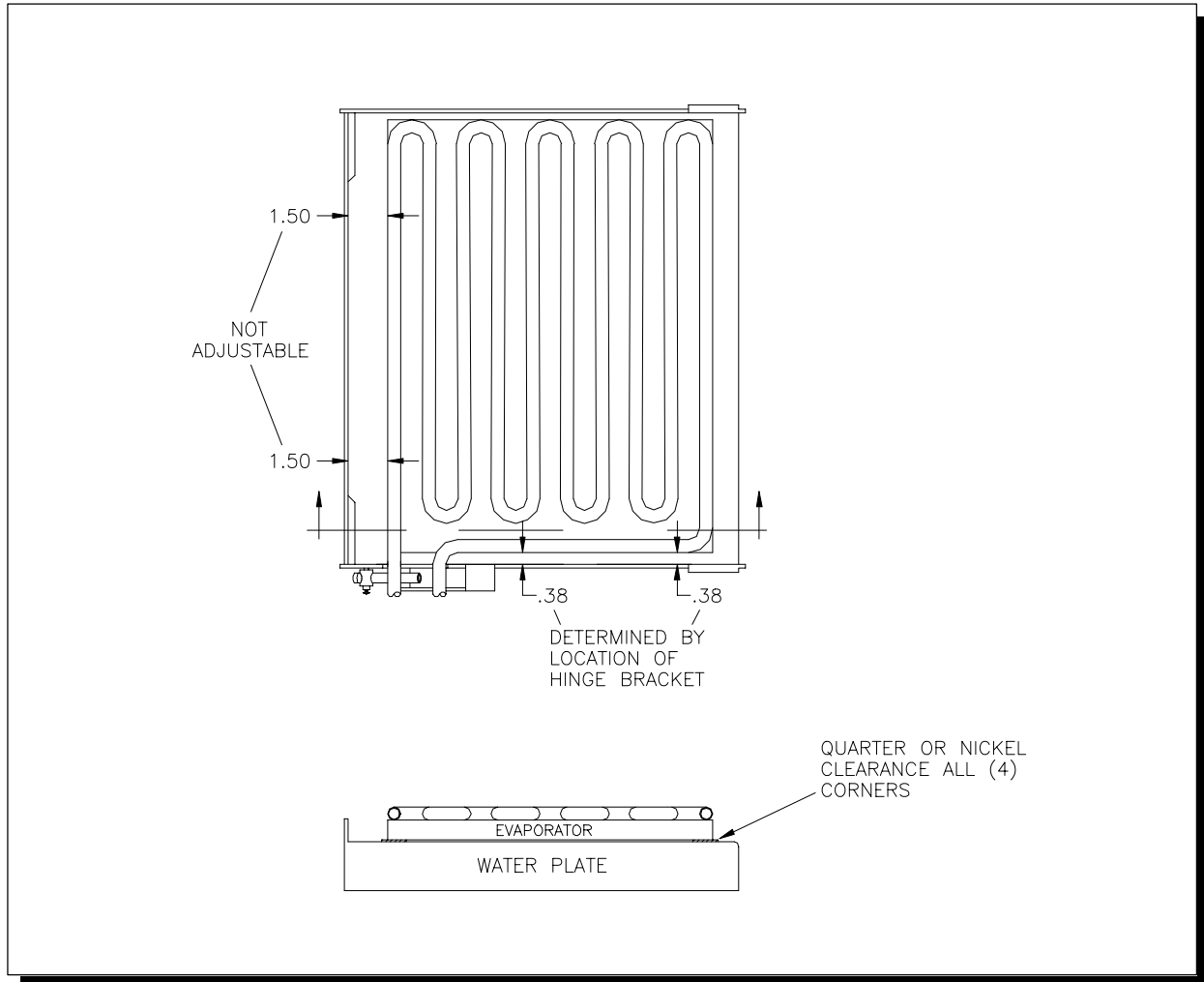

If water injection holes on the water plate become blocked with scale, some of the freezing cells will be void of ice at time of harvest. This condition may be cured by using a 1/16" drill bit to clean the injection holes with care not to scratch the water plate surface. Empty cells may collapse due to expansion of ice in adjacent cells.

If the holes are cleaned and no water flows through them to form ice in the cells, the lateral conduits have become clogged. To clean the laterals, remove the plugs at the right end of the water plate. Run a small brush through the laterals and flush out the foreign material. When replacing the plugs use new ones as the old ones have aged and may not seal properly. To replace a plug, push it in with an Allen wrench or similar blunt end tool. This stretches the plug so it will be tight when the tool is removed.

Service and Troubleshooting

A crack in the lateral strip on the underside of the water plate may prevent the control stream from rising and going over the dam. This could extend the freeze cycle and freeze ice into the water plate. If this occurs, the water plate should be replaced.

In some areas where water is unusually pure with practically no dissolved solids, the water plates may require fairly frequent applications of Kold-Draft water plate spray in order to prevent excessive ice adherence. Where water conditions cause ice to stick to the water plate, treatment is recommended every three months, or whenever cuber is cleaned or serviced. Decreasing the water fill level, so that harvest occurs without control stream function, may also be recommended.

KOLD-DRAFT WATER PLATE SPRAY APPLICATION:

1. Defrost the unit by pulling down on the water plate. With the "ICE-OFF-WASH" switch pressed to "WASH", allow the water tank to refill and circulate for a few minutes to melt off any accumulated ice. Open the plate to dump out the water.
2. Turn off the power with water plate open. Wipe water drops off evaporator and with several rags, and wipe the water plate as dry as possible.
3. Apply KOLD-DRAFT Water Plate Spray (55R-01052) to the water plate being sure to avoid the last half-inch along the right side. If the coating gets on this edge, the rinse water will run off into the bin during harvest.
4. Allow the coating to dry as long as practical, then buff the surface with soft cloth.
5. Turn on the power and press the "ICE-OFF-WASH" switch to "ICE".

REMOVAL OF WATER PLATE AND TANK ASSEMBLY:

1. Turn off the water and allow the plate to close; then turn off power.
2. Remove the control stream drain hose.
3. Remove the water level probe assembly by sliding it to the right beyond the control stream box and lift. Disconnect the tube assembly from the main tank.
4. Remove the pump mounting screws and the inlet and outlet hoses from the pump. Separate the pump from the front hinge and position out of the way.
5. Run the cams down to the 7 o'clock position (water plate open). Unhook the springs from the water plate.
6. Carefully pry the plastic hinges away from the plate.
7. Move the water plate and tank assembly to the right and forward out of the cuber. This may be facilitated by removing the drain pan and ice chute.

WATER PLATE REPLACEMENT:

1. Remove the spring bosses, water pump brace, water deflector, stainless steel wear plates, and water tank from the old water plate.
2. Remove the pump switch lift tab from the shoulder on the water plate and install in the new water plate.
3. Attach the tank to the new water plate and attach the stainless wear plates, water deflector, water plate brace and spring bosses. Be sure not to strip the plastic threads when tightening the boss bolts.

Service and Troubleshooting

RE-INSTALLING THE WATER PLATE AND TANK ASSEMBLY:

1. With the open end of the water plate to the right, slide it back into the cuber and to the left of its normal position.
2. Connect the springs to the water plate, front spring first. Place open end of spring loop into the boss groove and pull spring into position.
3. Hook on the plastic hinge brackets, and snap in place.
4. Re-position the water pump, align water pump brace with lower hole and secure with mounting screws. Install the inlet and outlet hoses to the pump. When installing the pump to tank hose, it is usually easier to put it on the tank first with one finger inside the hose. Slide the hose onto the pump connection taking care to avoid any twist or kink. The hoses will slide on easier if wet.
5. Reinstall the water level probe assembly and control stream drain hose.
6. Close water plate, making sure it is aligned and clears the thermostat bulb well on the front of the evaporator.

LIQUID LEVEL CONTROLLER

The liquid level controller (P.C. card and probes) is described in the **Controls and Adjustments** section. It is important to remember that this control does not directly energize the water fill solenoid valve while the actuator thermostat is switched cold. Water plate rinse during harvest is powered through the actuator switch only while the water plate is opening, and rinse flow stops when the water plate is fully open. Water fill begins when the actuator thermostat switches warm, after ice harvests, and the water plate begins to close.

The control circuit senses minute electrical conductivity through the water between the probes. Even very pure water is somewhat conductive and changing the sensitivity adjustment from mid-range should not be required.

Although the probe terminals (Low, High, Com) at the top of the Card operate at low voltage (12 volts), all other Card terminals carry line voltage (115 to 230 volts) with the obvious potential for electrical shock. Do not allow the Card to get wet, and use caution when checking voltages.

Before testing the water level control, be sure that:

- >There is line voltage at the INPUT terminals;
- >The control switch is in the "WASH" position;
- >The water supply is ON;
- >The water plate is fully closed with the pump switch held up;
- >There is no ice in the evaporator (actuator thermostat "WARM").

CONTROLLER TEST PROCEDURE:

The water valve should be energized if none of the probes are contacting water. If the valve won't open, **measure** the voltage at the valve coil. If zero volts, check for possible conductive path through water or mineral deposits on the control tube cap. If still

Service and Troubleshooting

zero, check control output between "N.O." terminal and the brown, blue or white **input** wire. Replace control if **line voltage** is not measured between these points.

If the water valve shuts off when the water level reaches the **lower** probe, check for reversed probe connections on the control. If not, then replace the control.

If the water valve does not shut off when the water level reaches the high level probe, press the "ICE-OFF-WASH" switch to "OFF" to check the valve for mechanical solenoid valve failure. Verify that the water supply is adequate, and if so repair or replace the solenoid valve if water flow does not stop with control switch in the "OFF" position.

If the valve closes with the switch in the "OFF" position, press the switch to "WASH", **unplug the "COM" probe** then short between the "COM" and "HIGH" probe terminals on the card. The on-card relay should cycle (view the contacts) each time these terminals are shorted and opened; if not, replace the control.

If the relay cycles but the water valve won't close, check the control output (bottom terminals) wire connections against the wiring diagram to be sure that the wiring is correct before replacing the control.

If the probe reaction time is erratic, try cleaning the probes and/or adjusting the sensitivity adjustment CW.

When replacing the control, be sure that a 115V control (P/N 102120601) is used in 115V Cubers and that a 230V control (P/N 102114201) is used in 230V Cubers. The controls are *not* interchangeable! **Check the label on the controller relay for the correct operating voltage.**

DUAL EVAPORATOR MODEL NOTE: If Master and Slave water fill level difference is greater than 1/4" for "K" or 1/8" for "C" or "HK" cubes, and no defect is found in the controller circuit, be sure that the water supply pressure is adequate (minimum 20 psig, dynamic) and that strainers, filters or valves are not causing restriction. If not, one of the solenoid valves is defective or the wrong valve is installed. Water fill should be completed within 1 1/2 minutes for GB "K", 2 minutes for GB "C" or "HK", 1 minute for GT3 "K", or 1 1/2 minutes for GT3 "C" or "HK", after the water plate(S) begins closing.

CUBE QUALITY

Proper adjustment of the control stream and water level probes will produce ice cubes containing a 1/8" to 3/16" dimple. Oversized dimples may be caused by insufficient water fill, control stream set too high and/or a leak in the water circulation system. Undersized dimples are caused by overfilling, control stream set too low and/or mis-adjustment of the low level probe.

Service and Troubleshooting

Cubes which are solid in one part of the evaporator while hollow in another may be caused by clogged water plate laterals or water plate injection holes, an incorrect refrigerant charge and/or mis-adjusted TEV.

Start-up cycles may exhibit supercooling of the circulating water resulting in the formation of slush in the circulation system which may reduce or shut off the flow of water at the control stream momentarily. This is not a problem unless the control stream rises above the dam when full circulation resumes after the system is fully warmed up (3 cycles, minimum) and all the cabinet panels are installed. The symptoms of this abnormal condition may be excessively large, uniform holes in cubes and/or refilling with water, usually along with hot gas due to the cold water thermostat, within about 5 minutes after freeze cycle begins. If lowering the control stream adjustment to avoid the abnormal loss of water over the dam does not help consistently, try increasing the TEV superheat adjustment 1/4 to 1/2 turn.

Compressor Chart

Model	Item	Original Equipment		1995 Retrofit, (R-502/R-404a)		1998 Retrofit (Tecumseh)	
		Part No.	Description	Part No.	Description	Part No.	Description
GT331 (115/60)	Compressor	102 1191 08	M51B542BBAB	*102 1242 01	M61B542BBAB	*102 1242 11	AKA9451ZXA
	Start Relay	102 1047 04	---	102 1047 04	---	102 1047 09	---
	Start Capacitor	102 1195 03	145-175/250	102 1195 03	145-175/250	102 1195 08	72-88/250
	Run Capacitor	102 1044 01	15/370	102 1044 01	15/370	102 1197 04	25/370
	Overload	Internal	---	Internal	---	102 1198 02	---
GT334 (208-230/60)	Compressor	102 1191 11	M51B542BBCB	102 1191 19	M61B542BBCB	*102 1242 12	AKA9451ZXD
	Start Relay	102 1047 06	---	102 1047 06	---	102 1047 06	---
	Start Capacitor	102 1195 06	108-130/250	102 1195 06	108-130/250	102 1195 02	72-88/330
	Run Capacitor	102 1044 01	15/370	102 1044 01	15/370	102 1044 01	15/370
	Overload	Internal	---	Internal	---	102 1198 08	---
GT337 (220-240/50)	Compressor	102 1191 04	M51B872BBKB	---	---	*102 1242 13	AKA9451ZXC
	Start Relay	102 1047 03	---	---	---	102 1047 10	---
	Start Capacitor	102 1196 01	88-108/250	---	---	102 1195 02	72-88/330
	Run Capacitor	102 1197 04	25/370	---	---	102 1044 01	15/370
	Overload	Internal	---	---	---	102 1198 04	---
GT341 (115/60)	Compressor	102 1191 16	M61B542BBAB	---	---	*102 1242 11	AKA9451ZXA
	Start Relay	102 1047 04	---	---	---	102 1047 09	---
	Start Capacitor	102 1195 03	145-175/250	---	---	102 1195 08	72-88/250
	Run Capacitor	102 1044 01	15/370	---	---	102 1197 04	25/370
	Overload	Internal	---	---	---	102 1198 02	---
GT344 (208-230/60)	Compressor	102 1191 19	M61B542BBCB	---	---	*102 1242 12	AKA9451ZXD
	Start Relay	102 1047 06	---	---	---	102 1047 06	---
	Start Capacitor	102 1195 06	108-130/250	---	---	102 1195 02	72-88/330
	Run Capacitor	102 1044 01	15/370	---	---	102 1044 01	15/370
	Overload	Internal	---	---	---	102 1198 08	---
GT347 (220-240/50)	Compressor	102 1191 14	M65B802BBKB	---	---	*102 1242 13	AKA9451ZXC
	Start Relay	102 1047 07	---	---	---	102 1047 10	---
	Start Capacitor	102 1195 03	145-175/250	---	---	102 1195 02	72-88/330
	Run Capacitor	102 1197 01	25/440	---	---	102 1044 01	15/370
	Overload	Internal	---	---	---	102 1198 04	---

* Indicates compressor retrofit kit including start relay, capacitors, filter-drier, and retrofit parts as required for some models.

Compressor Chart

Model	Item	Original Equipment		1995 Retrofit, (R-502/R-404a)		1998 Retrofit, (Tecumseh)	
		Part No.	Description	Part No.	Description	Part No.	Description
GT351 (115/60)	Compressor	102 1191 24	AKA9451ZXA	---	---	---	---
	Start Relay	102 1047 09	---	---	---	---	---
	Start Capacitor	102 1195 08	72-88/250	---	---	---	---
	Run Capacitor	102 1197 04	25/370	---	---	---	---
	Overload	102 1198 02	---	---	---	---	---
GT354 (208-230/60)	Compressor	102 1191 32	AKA9451ZXD	---	---	---	---
	Start Relay	102 1047 06	---	---	---	---	---
	Start Capacitor	102 1195 02	72-88/330	---	---	---	---
	Run Capacitor	102 1044 01	15/370	---	---	---	---
	Overload	102 1198 08	---	---	---	---	---
GT357 (220-240/50)	Compressor	102 1191 25	AKA9451ZXC	---	---	---	---
	Start Relay	102 1047 10	---	---	---	---	---
	Start Capacitor	102 1195 02	72-88/330	---	---	---	---
	Run Capacitor	102 1044 01	15/370	---	---	---	---
	Overload	102 1198 04	---	---	---	---	---
GT551 (115/60)	Compressor	102 1191 21	AKA9462ZXA	---	---	---	---
	Start Relay	102 1047 09	---	---	---	---	---
	Start Capacitor	102 1195 08	72-88/250	---	---	---	---
	Run Capacitor	102 1197 04	25/370	---	---	---	---
	Overload	102 1198 03	---	---	---	---	---
GB421 (115/60)	Compressor	102 1191 01	RSU5-0050-IAA	*102 1242 02	M65B802BBAB	*102 1242 15	AKA9455ZXA
	Start Relay	102 1048 01	---	102 1047 04	---	102 1047 09	---
	Start Capacitor	GTR-00373-02	270-324/165	GBR-02353-02	189-227/330	102 1195 08	72-88/250
	Run Capacitor	102 1044 01	15/370	GBR-01385-03	20/370	102 1197 04	25/370
	Overload	102 1198 01	---	Internal	---	102 1198 06	---
GB427 (220-240/50)	Compressor	102 1192 01	RSU5-0050-IAZ	*102 1242 04	M65B802BBKB	*102 1242 17	AKA9462ZXC
	Start Relay	102 1194 01	---	102 1047 07	---	102 1047 11	---
	Start Capacitor	102 1195 01	43-52/330	102 1195 03	145-175/250	102 1195 02	72-88/330
	Run Capacitor	---	---	102 1197 01	25/440	102 1044 01	15/370
	Overload	102 1199 01	---	Internal	---	102 1198 05	---

* Indicates compressor retrofit kit including start relay, capacitors, filter-drier, and retrofit parts as required for some models.

Compressor Chart

Model	Item	Original Equipment		1995 Retrofit, (R-502/R-404a)		1998 Retrofit, (Tecumseh)	
		Part No.	Description	Part No.	Description	Part No.	Description
GB431 (115/60)	Compressor	102 1191 03	M51B872BBAB	*102 1242 02	M65B802BBAB	*102 1242 15	AKA9455ZXA
	Start Relay	102 1047 04	---	102 1047 04	---	102 1047 09	---
	Start Capacitor	102 1195 03	145-175/250	GBR-02353-02	189-227/330	102 1195 08	72-88/250
	Run Capacitor	102 1044 01	15/370	GBR-01385-03	20/370	102 1197 04	25/370
	Overload	Internal	---	Internal	---	102 1198 06	---
GB434 (208-230/60)	Compressor	102 1191 10	M51B872BBAB	102 1191 20	M65B802BBAB	*102 1242 18	AKA9455ZXD
	Start Relay	102 1047 02	---	102 1047 08	---	102 1047 06	---
	Start Capacitor	102 1195 06	108-130/250	102 1195 05	161-193/250	102 1195 02	72-88/330
	Run Capacitor	102 1044 01	15/370	102 1197 01	25/440	102 1044 01	15/370
	Overload	Internal	---	Internal	---	102 1198 07	---
GB437 (220-240/50)	Compressor	102 1191 04	M51B872BBKB	*102 1242 04	M65B802BBKB	*102 1242 17	AKA9462ZXC
	Start Relay	102 1047 03	---	102 1047 07	---	102 1047 11	---
	Start Capacitor	102 1196 01	88-108/250	102 1195 03	145-175/250	102 1195 02	72-88/330
	Run Capacitor	102 1197 04	25/370	102 1197 01	25/440	102 1044 01	15/370
	Overload	Internal	---	Internal	---	102 1198 05	---
GB441 (115/60)	Compressor	102 1191 13	M65B802BBAB	---	---	*102 1042 15	AKA9455ZXA
	Start Relay	102 1047 04	---	---	---	102 1047 09	---
	Start Capacitor	GBR-02353-02	189-227/330	---	---	102 1195 08	72-88/250
	Run Capacitor	GBR-01385-03	20/370	---	---	102 1197 04	25/370
	Overload	Internal	---	---	---	102 1198 06	---
GB444 (208-230/60)	Compressor	102 1191 20	M65B802BBAB	---	---	*102 1242 18	AKA9455ZXD
	Start Relay	102 1047 08	---	---	---	102 1047 06	---
	Start Capacitor	102 1195 05	161-193/250	---	---	102 1195 02	72-88/330
	Run Capacitor	102 1197 01	25/440	---	---	102 1044 01	15/370
	Overload	Internal	---	---	---	102 1198 07	---
GB447 (220-240/50)	Compressor	102 1191 14	M65B802BBKB	---	---	*102 1242 17	AKA9462ZXC
	Start Relay	102 1047 07	---	---	---	102 1047 11	---
	Start Capacitor	102 1195 03	145-175/250	---	---	102 1195 02	72-88/330
	Run Capacitor	102 1197 01	25/440	---	---	102 1044 01	15/370
	Overload	Internal	---	---	---	102 1198 05	---

* Indicates compressor retrofit kit including start relay, capacitors, filter-drier, and retrofit parts as required for some models.

Compressor Chart

Model	Item	Original Equipment		1995 Retrofit, (R-502/R-404a)		1998 Retrofit, (Tecumseh)	
		Part No.	Description	Part No.	Description	Part No.	Description
GB451 (115/60)	Compressor	102 1191 28	AKA9455ZXA	---	---	---	---
	Start Relay	102 1047 09	---	---	---	---	---
	Start Capacitor	102 1195 08	72-88/250	---	---	---	---
	Run Capacitor	102 1197 04	25/370	---	---	---	---
	Overload	102 1198 06	---	---	---	---	---
GB454 (208-230/60)	Compressor	102 1191 31	AKA9455ZXD	---	---	---	---
	Start Relay	102 1047 06	---	---	---	---	---
	Start Capacitor	102 1195 02	72-88/330	---	---	---	---
	Run Capacitor	102 1044 01	15/370	---	---	---	---
	Overload	102 1198 07	---	---	---	---	---
GB457 (220-240/50)	Compressor	102 1191 29	AKA9462ZXC	---	---	---	---
	Start Relay	102 1047 11	---	---	---	---	---
	Start Capacitor	102 1195 02	72-88/330	---	---	---	---
	Run Capacitor	102 1044 01	15/370	---	---	---	---
	Overload	102 1198 05	---	---	---	---	---
GB624 (208-230/60)	Compressor	102 1193 01	RSL5-0100-CAV	*102 1242 03	M65B133BBC	*102 1242 14	AWA7512ZXD
	Start Relay	GBR-01385-01	---	102 1047 05	---	102 1047 13	---
	Start Capacitor	102 1196 01	88-108/250	102 1195 05	161-193/250	102 1195 09	130-156/330
	Run Capacitor	102 1197 01	25/440	102 1197 01	25/440	102 1197 02	35/370
	Overload	102 1200 01	---	Internal	---	Internal	---
GB627 (220-240/50)	Compressor	102 1191 02	RSL5-0101-PFJ	*102 1242 05	M65B133BBKB	*102 1242 16	AWA7512ZXC
	Start Relay	GBR-01385-01	---	102 1047 03	---	102 1047 12	---
	Start Capacitor	102 1195 02	72-86/330	102 1195 04	124-149/250	102 1195 10	88-108/330
	Run Capacitor	102 1197 02	35/370	GBR-01385-03	20/370	102 1197 02	35/370
	Overload	---	---	---	---	---	---
GB634 (208-230/60)	Compressor	102 1191 05	M51B123BBCB	*102 1042 03	M65B133BBCB	*102 1242 14	AWA7512ZXD
	Start Relay	102 1047 02	---	102 1047 05	---	102 1047 13	---
	Start Capacitor	102 1195 04	124-149/250	102 1195 05	161-193/250	102 1195 09	130-156/330
	Run Capacitor	GBR-01385-03	20/370	102 1197 01	25/440	102 1197 02	35/370
	Overload	---	---	---	---	---	---
GB637 (220-240/50)	Compressor	102 1191 06	M51B143BBKB	*102 1242 05	M65B133BBKB	*102 1042 16	AWA7512ZXC
	Start Relay	102 1047 03	---	102 1047 03	---	102 1047 12	---
	Start Capacitor	102 1195 04	124-149/250	102 1195 04	124-149/250	102 1195 10	88-108/330
	Run Capacitor	GBR-01385-03	20/370	GBR-01385-03	20/370	102 1197 02	35/370
	Overload	---	---	---	---	---	---

* Indicates compressor retrofit kit including start relay, capacitors, filter-drier, and retrofit parts as required for some models.

Compressor Chart

Model	Item	Original Equipment		1995 Retrofit, (R-502/R-404a)		1998 Retrofit, (Tecumseh)	
		Part No.	Description	Part No.	Description	Part No.	Description
GB644 (208-230/60)	Compressor	102 1191 09	M65B133BBCB	---	---	*102 1242 14	AWA7512ZXD
	Start Relay	102 1047 05	---	---	---	102 1047 13	---
	Start Capacitor	102 1195 05	161-193/250	---	---	102 1195 09	130-156/330
	Run Capacitor	102 1197 01	25/440	---	---	102 1197 02	35/370
GB647 (220-240/50)	Compressor	102 1191 15	M65B133BBKB	---	---	*102 1242 16	AWA7512ZXC
	Start Relay	102 1047 03	---	---	---	102 1047 12	---
	Start Capacitor	102 1195 04	124-149/250	---	---	102 1195 10	88-108/330
	Run Capacitor	GBR-01385 03	20/370	---	---	102 1197 02	35/370
GB654 (208-230/60)	Compressor	102 1191 26	AWA7512ZXD	---	---	---	---
	Start Relay	102 1047 13	---	---	---	---	---
	Start Capacitor	102 1195 09	130-156/330	---	---	---	---
	Run Capacitor	102 1197 02	35/370	---	---	---	---
GB657 (220-240/50)	Compressor	102 1191 27	AWA7512ZXC	---	---	---	---
	Start Relay	102 1047 12	---	---	---	---	---
	Start Capacitor	102 1195 10	88-108/330	---	---	---	---
	Run Capacitor	102 1197 02	35/370	---	---	---	---
GB1224 (208-230/60/1)	Compressor	GBR-02353	M53A273BBCA	*102 1242 06	M66A243BBCA	*102 1242 09	AVA7524ZXN
	Start Relay	GBR-02353-01	---	GBR-02353-01	---	102 1047 04	---
	Start Capacitor	GBR-02353-02	189-227/330	102 1195 05	161-193/250	102 1195 09	130-156/330
	Run Capacitor	GBR-01395-05	35/440	102 1197 05	40/440	102 1197 06	45/440
GB1225 (208-230/60/3)	Compressor	102 1191 12	M53A273DBDA	102 1191 18	M66A243DBDA	*102 1242 10	AVA7524ZXT
GB1244 (208-230/60/1)	Compressor	102 1191 17	M66A243BBCA	---	---	*102 1042 09	AVA7524ZXN
	Start Relay	GBR-02353-01	---	---	---	102 1047 04	---
	Start Capacitor	102 1195 05	161-193/250	---	---	102 1195 09	130-156/330
	Run Capacitor	102 1197 05	40/440	---	---	102 1197 06	45/440
GB1245 (208-230/60/3)	Compressor	102 1191 18	M66A243DBDA	---	---	*102 1242 10	AVA7524ZXT

* Indicates compressor retrofit kit including start relay, capacitors, filter-drier, and retrofit parts as required for some models.

Compressor Chart

Model	Item	Original Equipment		1995 Retrofit, (R-502/R-404a)		1998 Retrofit, (Tecumseh)	
		Part No.	Description	Part No.	Description	Part No.	Description
GB1254 (208-230/60/1)	Compressor	102 1191 22	AVA7524ZXN	---	---	---	---
	Start Relay	102 1047 04	---	---	---	---	---
	Start Capacitor	102 1195 09	130-156/330	---	---	---	---
	Run Capacitor	102 1197 06	45/440	---	---	---	---
GB1255 (208-230/60/3)	Compressor	102 1191 23	AVA7524ZXT	---	---	---	---
GT554 (208-230/60)	Compressor	102 1191 33	AKA9462ZXD	---	---	---	---
	Start Relay	102 1047 14	---	---	---	---	---
	Start Capacitor	102 1195 02	72-88/330	---	---	---	---
	Run Capacitor	102 1044 01	15/370	---	---	---	---
	Overload	102 1198 07	---	---	---	---	---

* Indicates compressor retrofit kit including start relay, capacitors, filter-drier, and retrofit parts as required for some models.

Wiring Diagrams

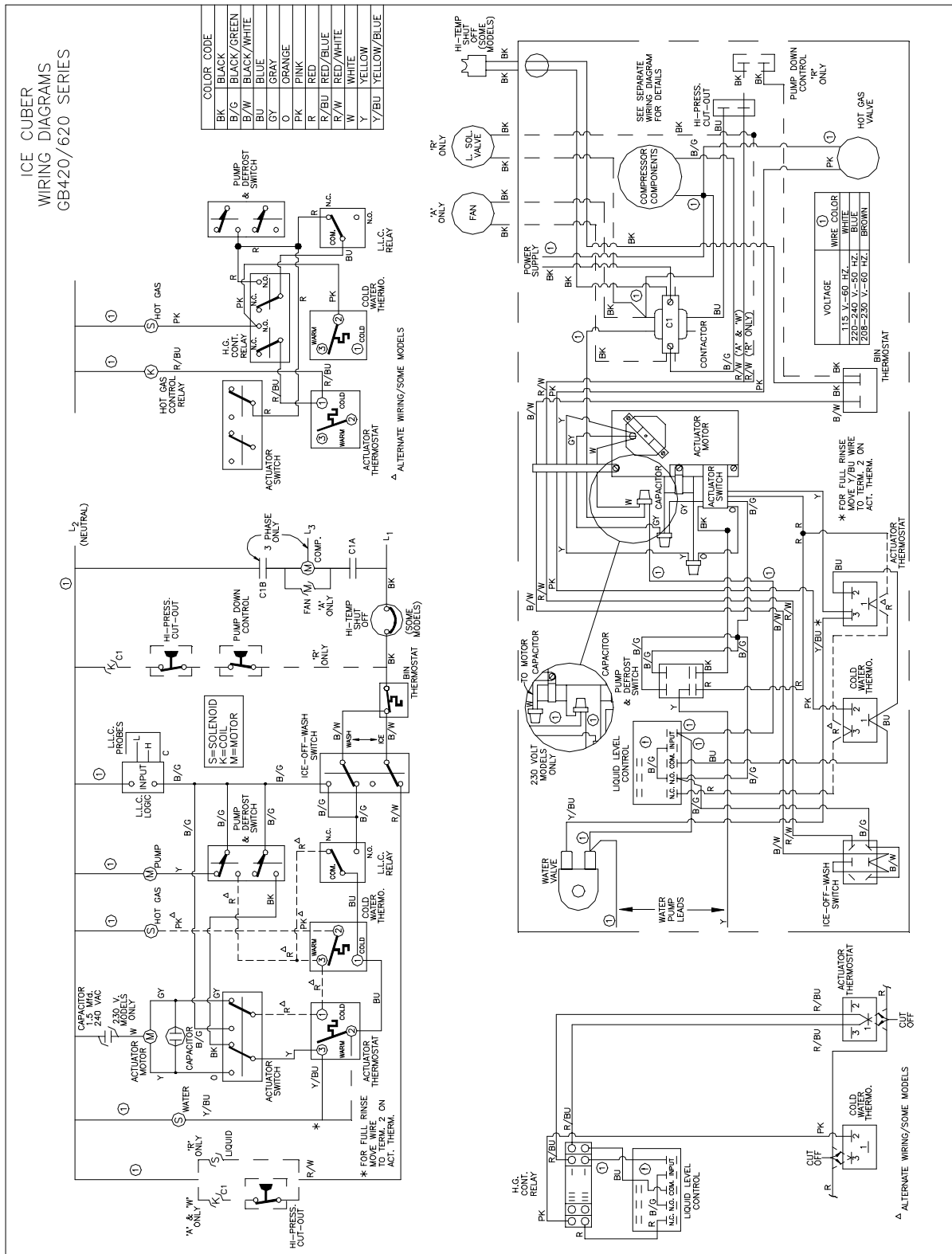

SEE ENG. BULLETIN #96001 FOR WIRING UPGRADE

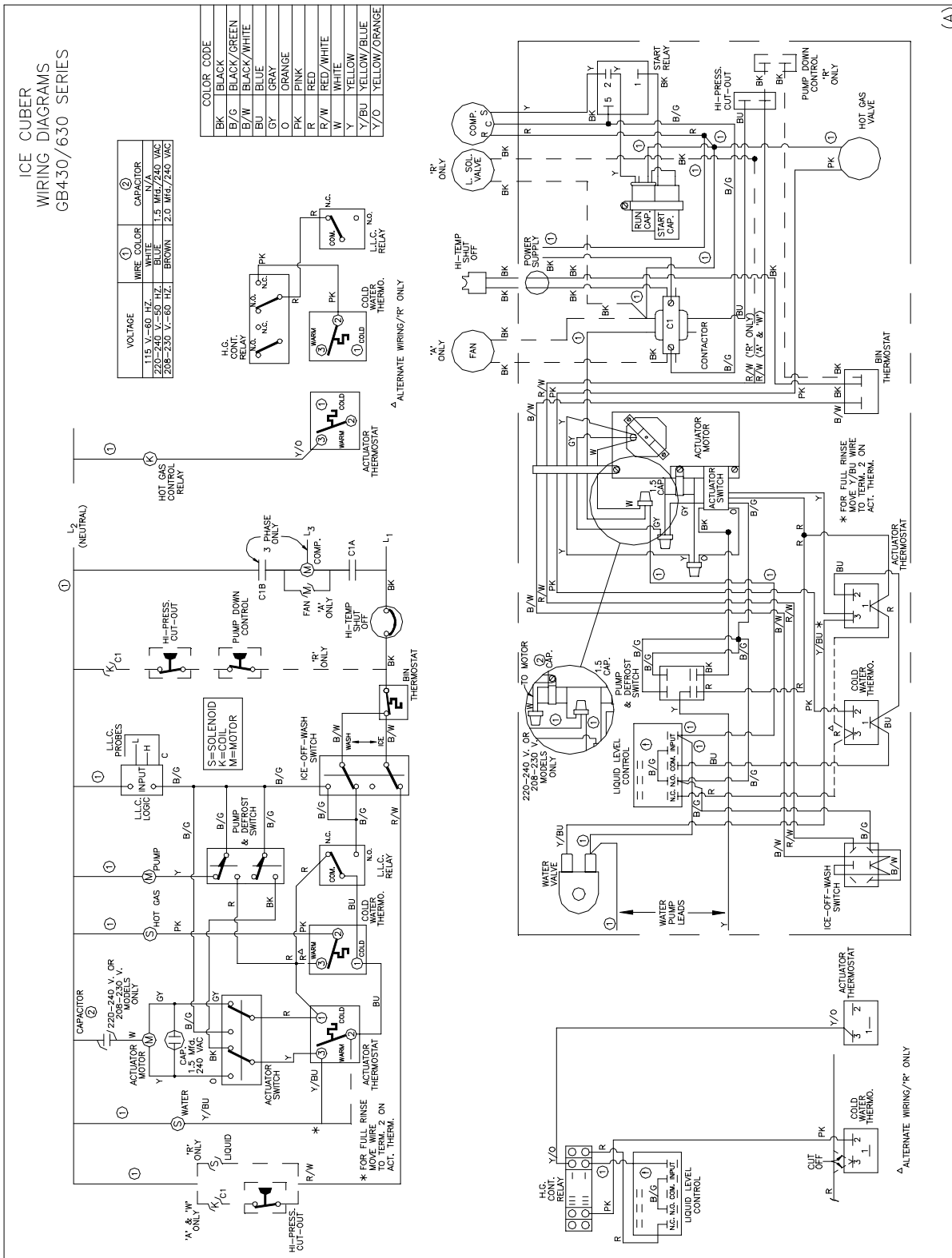

SEE ENG. BULLETIN #96001 FOR WIRING UPGRADE

Wiring Diagrams

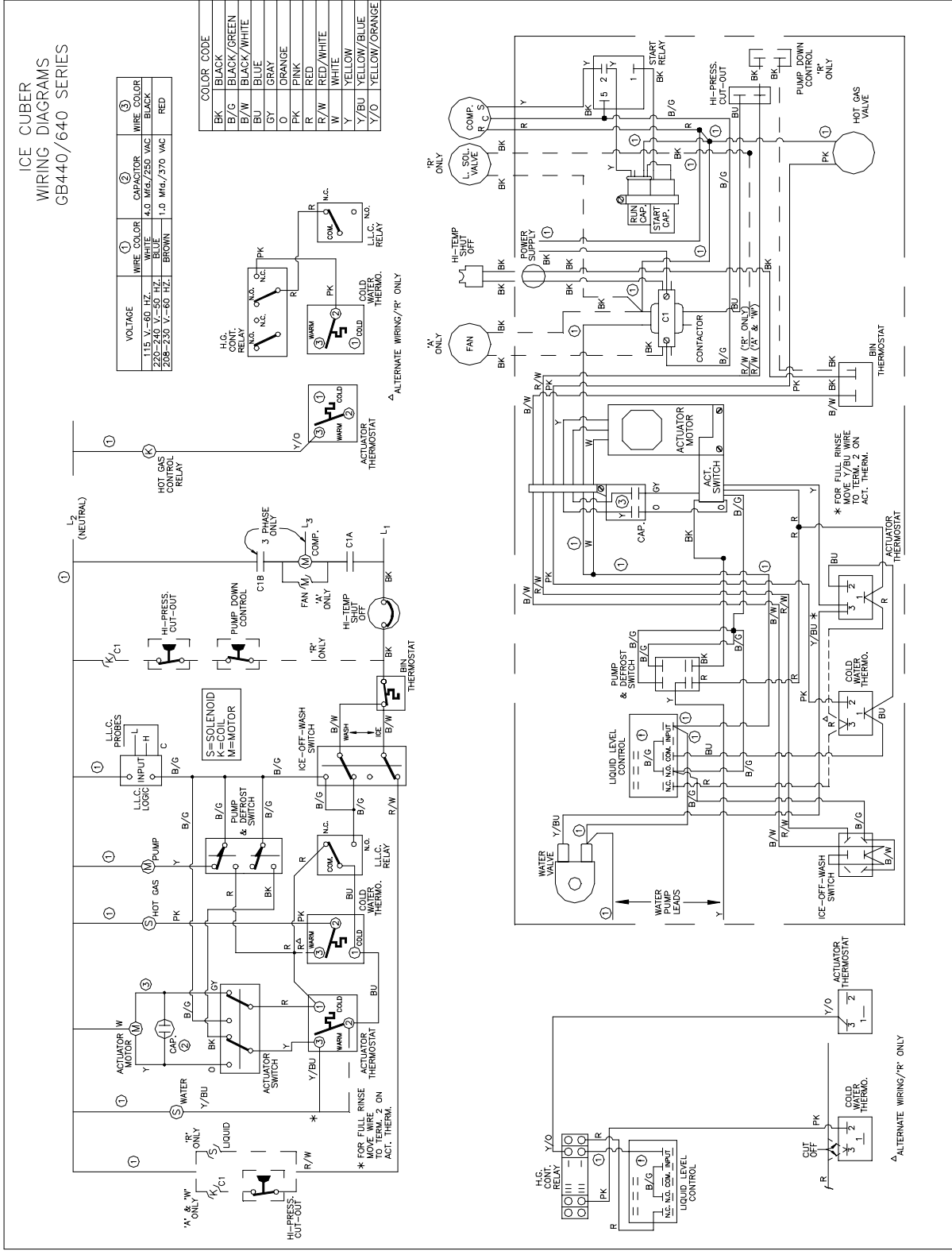

SEE ENG. BULLETIN #96001 FOR WIRING UPGRADE

Wiring Diagrams

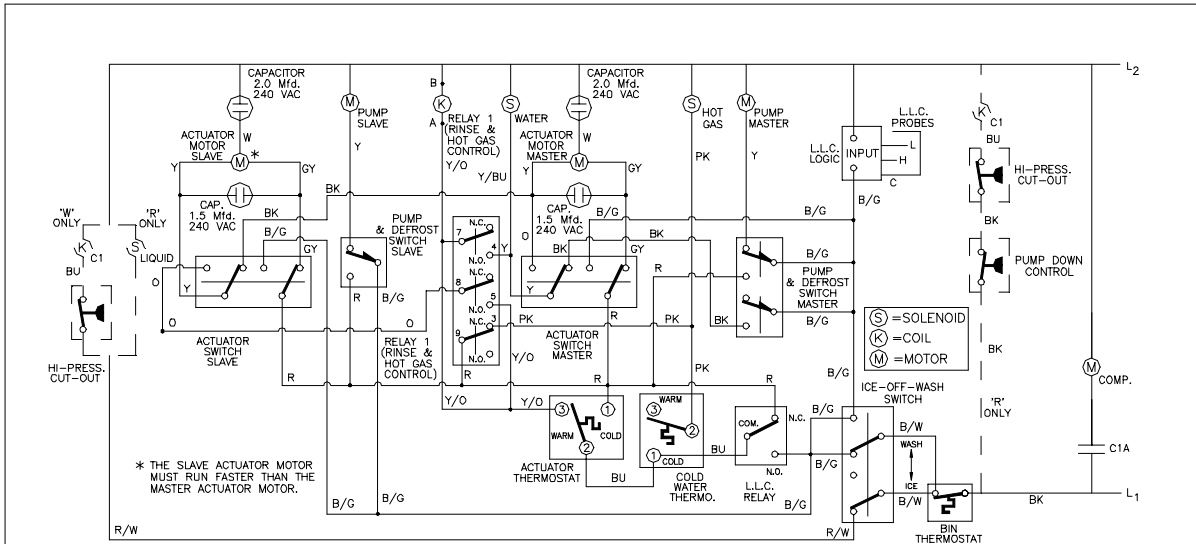

MASTER ELECTRICAL BOX

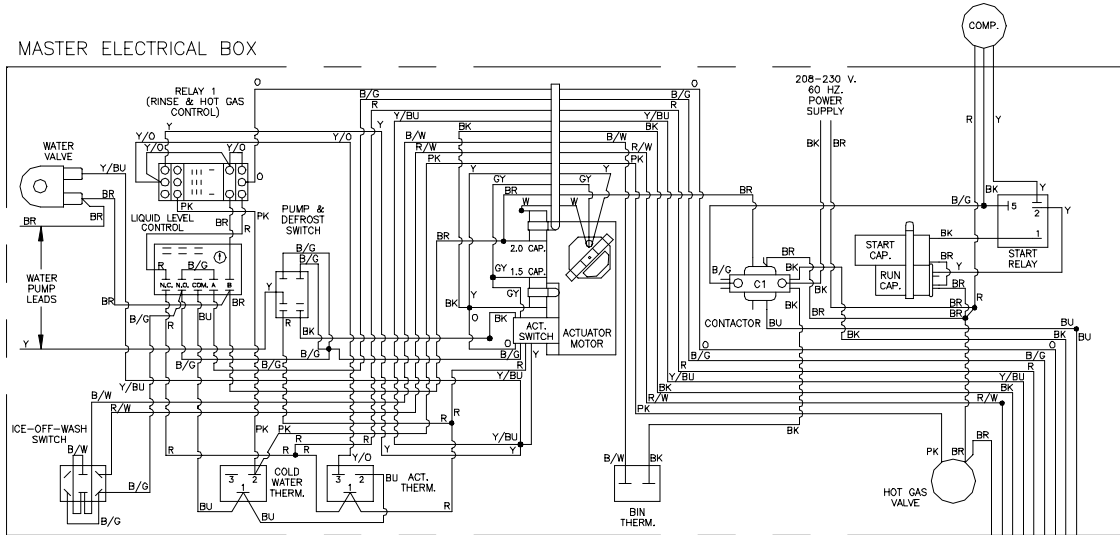

SLAVE ELECTRICAL BOX

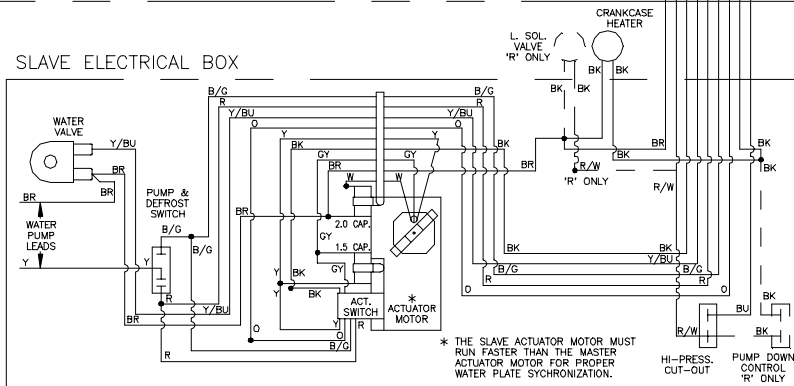

COLOR CODE	
BK	BLACK
B/G	BLACK/GREEN
B/W	BLACK/WHITE
BR	BROWN
BU	BLUE
GY	GRAY
O	ORANGE
PK	PINK
R	RED
R/W	RED/WHITE
W	WHITE
Y	YELLOW
Y/BU	YELLOW/BLUE
Y/O	YELLOW/ORANGE

ICE CUBER
WIRING DIAGRAMS
GB1224 (B)

SEE ENG. BULLETINS #96001, 96003, & 97001 FOR WIRING UPGRADES

Wiring Diagrams

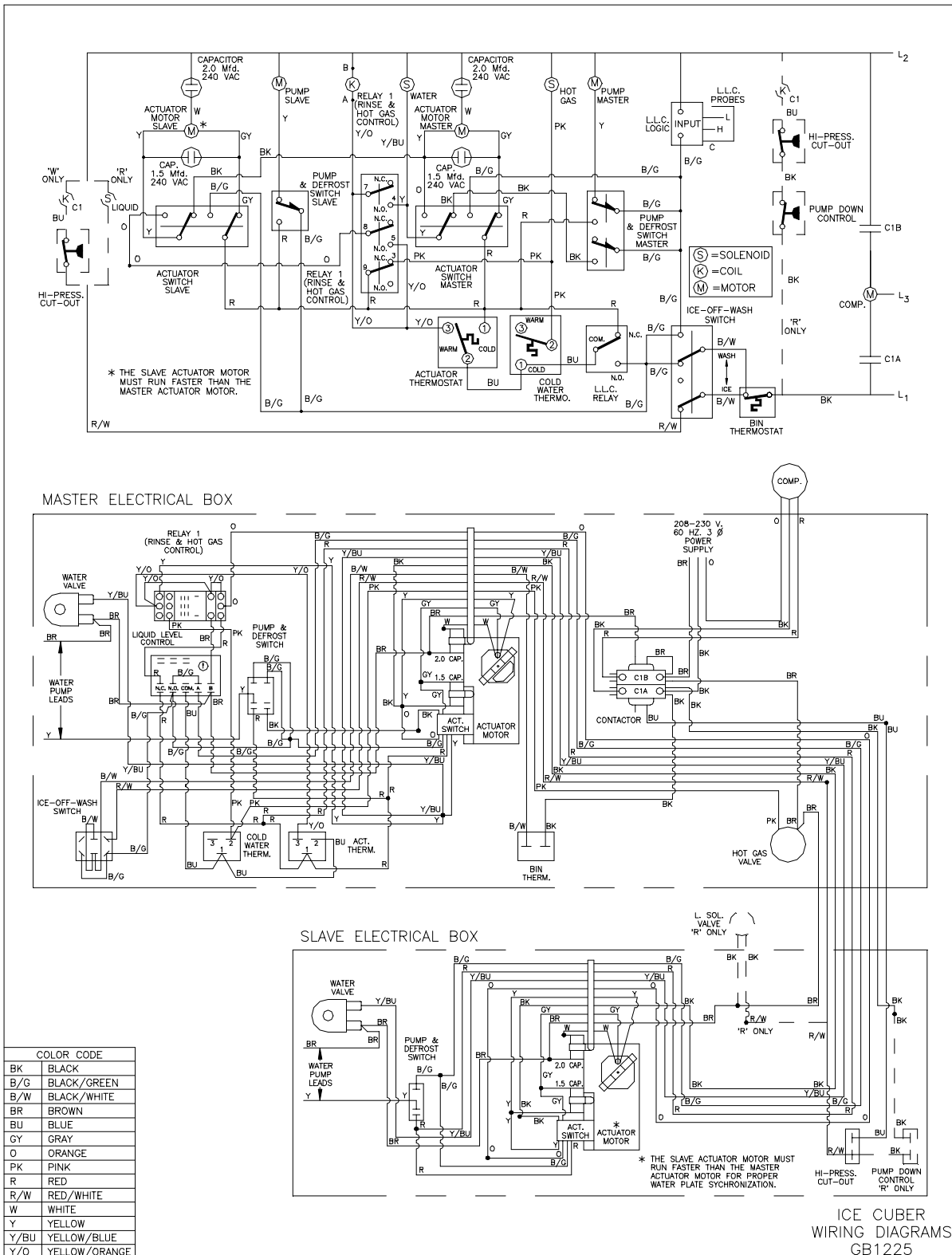

SEE ENG. BULLETINS #96001, 96003, & 97001 FOR WIRING UPGRADES

Wiring Diagrams

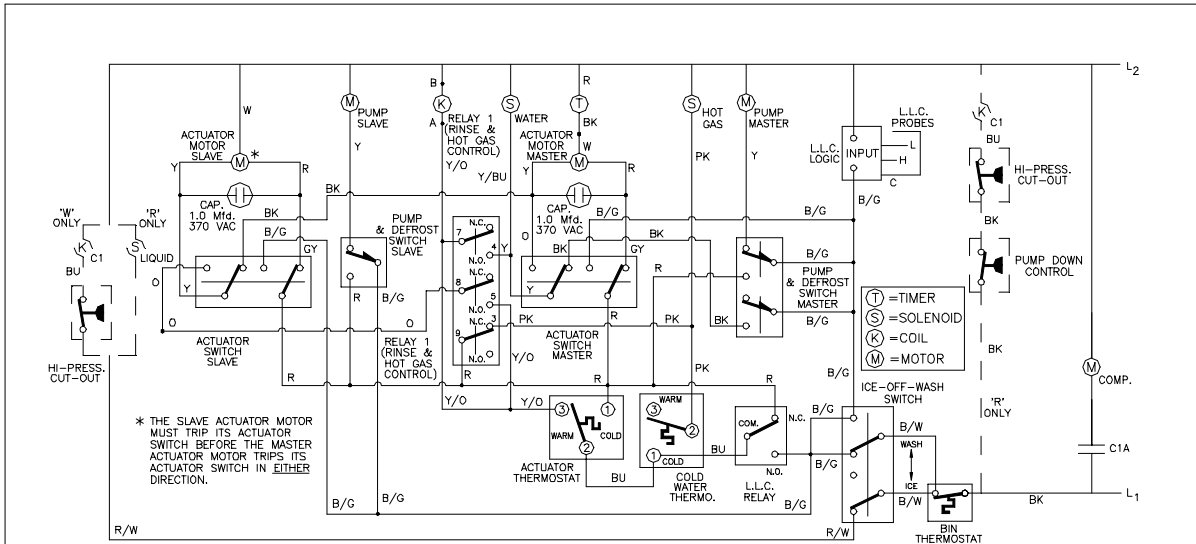

MASTER ELECTRICAL BOX

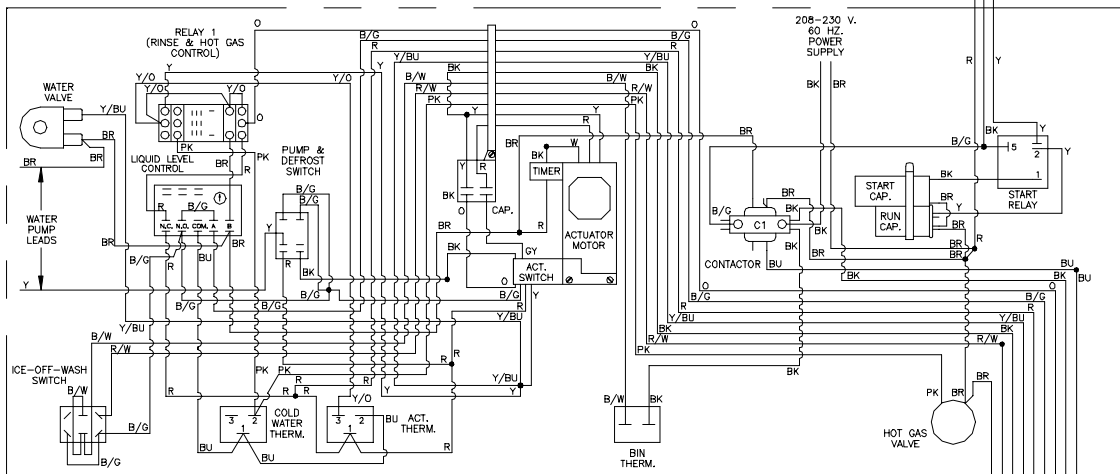

SLAVE ELECTRICAL BOX

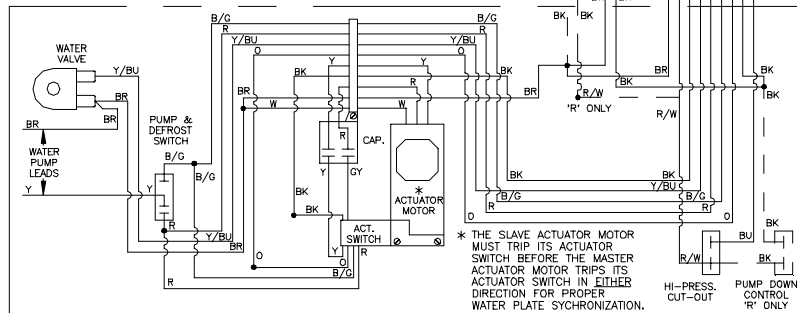

COLOR CODE	
BK	BLACK
B/G	BLACK/GREEN
B/W	BLACK/WHITE
BR	BROWN
BU	BLUE
GY	GRAY
O	ORANGE
PK	PINK
R	RED
R/W	RED/WHITE
W	WHITE
Y	YELLOW
Y/BU	YELLOW/BLUE
Y/O	YELLOW/ORANGE

ICE CUBER
 WIRING DIAGRAMS
 GB1244

SEE ENG. BULLETINS #96001, 96003, & 97001 FOR WIRING UPGRADES

Wiring Diagrams

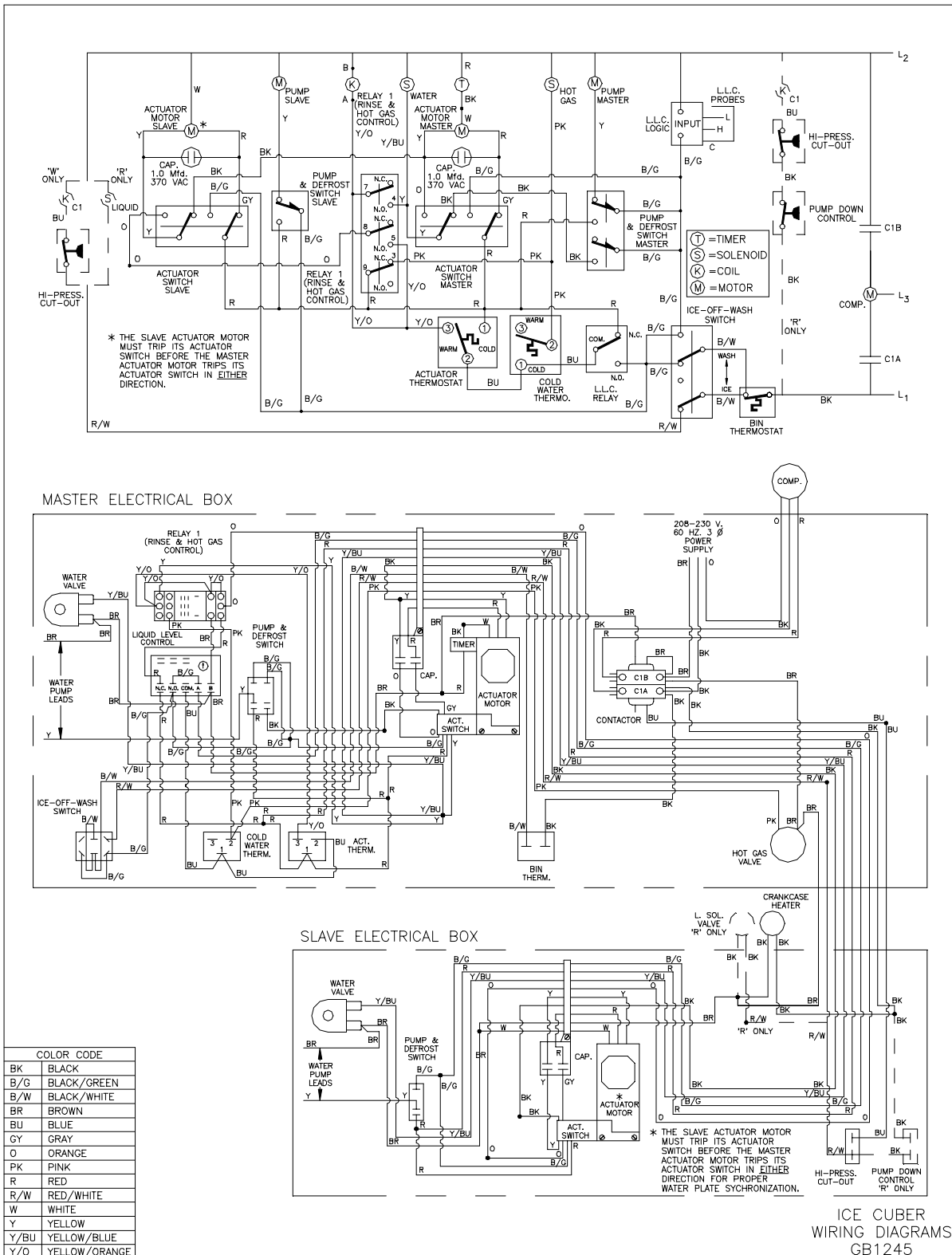

SEE ENG. BULLETINS #96001, 96003, & 97001 FOR WIRING UPGRADES

Wiring Diagrams

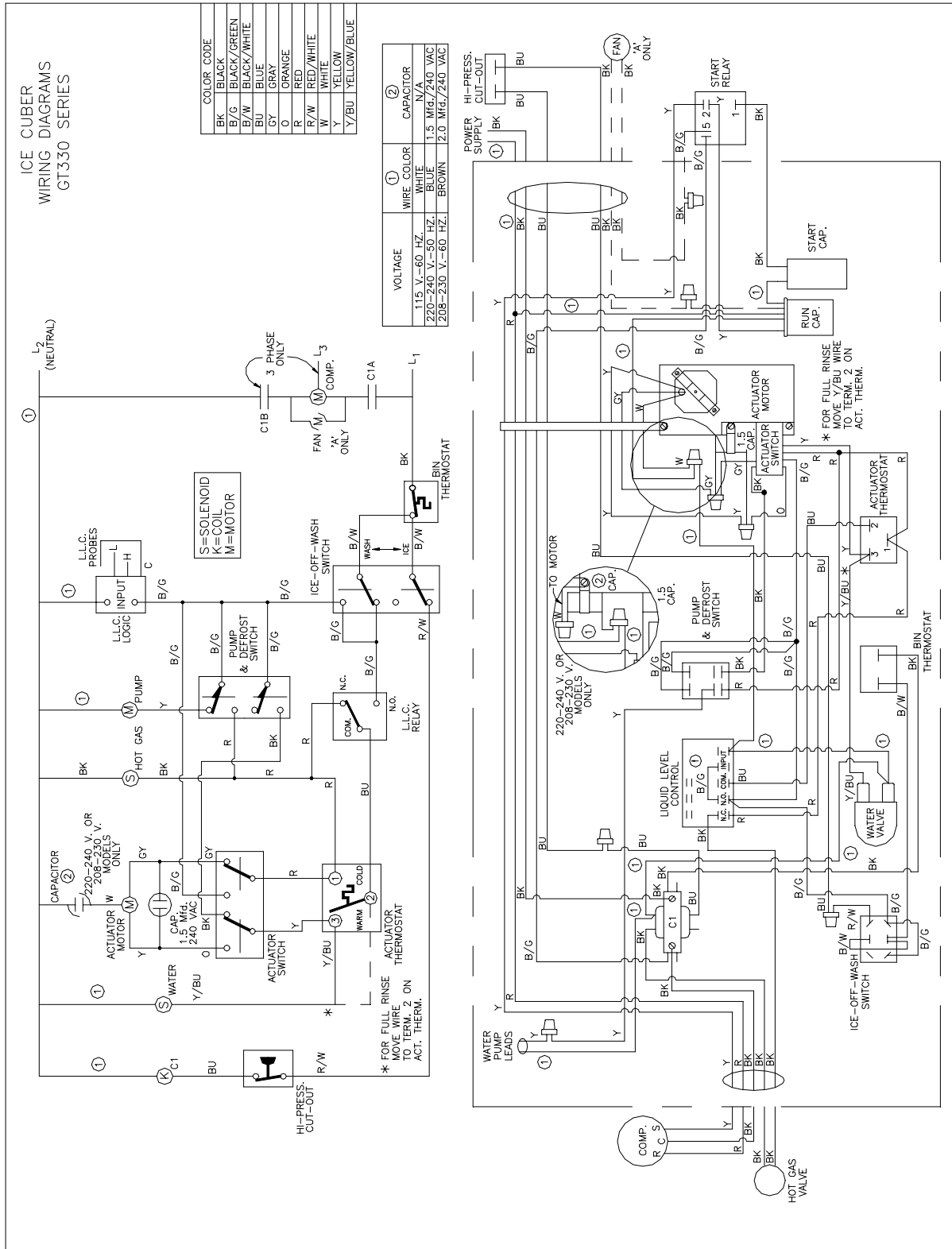

SEE ENG. BULLETIN #96001 FOR WIRING UPGRADE

Wiring Diagrams

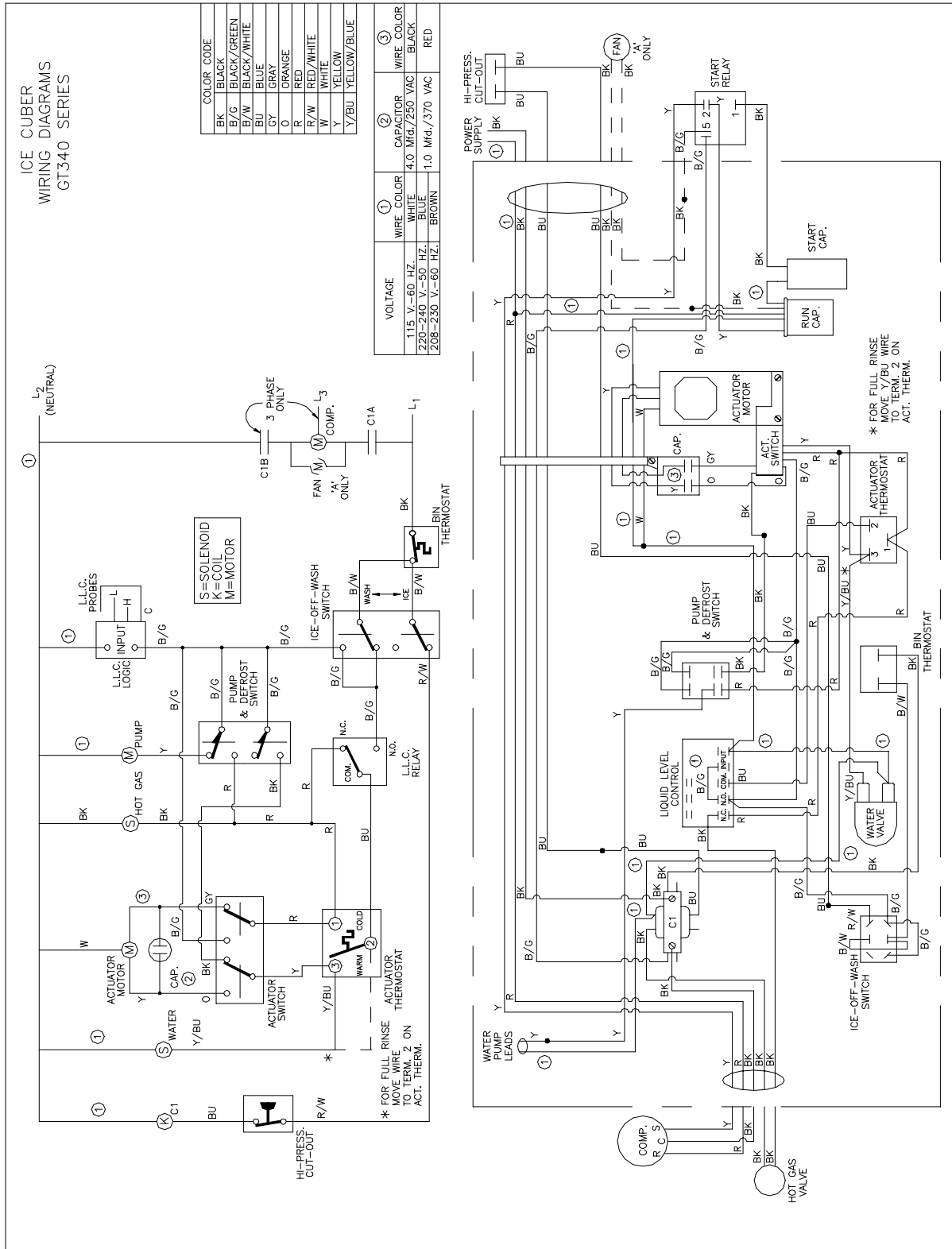

SEE ENG. BULLETIN #96001 FOR WIRING UPGRADE

Wiring Diagrams

ICE CUBER WIRING DIAGRAMS GB440/640 SERIES

VOLTAGE	① WIRE COLOR	② CAPACITOR	③ WIRE COLOR
115 V.-60 HZ.	WHITE	4.0 Mfd./250 VAC	BLACK
220-240 V.-50 HZ.	BLUE	1.0 Mfd./370 VAC	RED
208-230 V.-60 HZ.	BROWN		

COLOR CODE	
BK	BLACK
B/G	BLACK/GREEN
B/W	BLACK/WHITE
BU	BLUE
GY	GRAY
O	ORANGE
PK	PINK
R	RED
R/W	RED/WHITE
W	WHITE
Y/BU	YELLOW/BLUE
Y/O	YELLOW/ORANGE

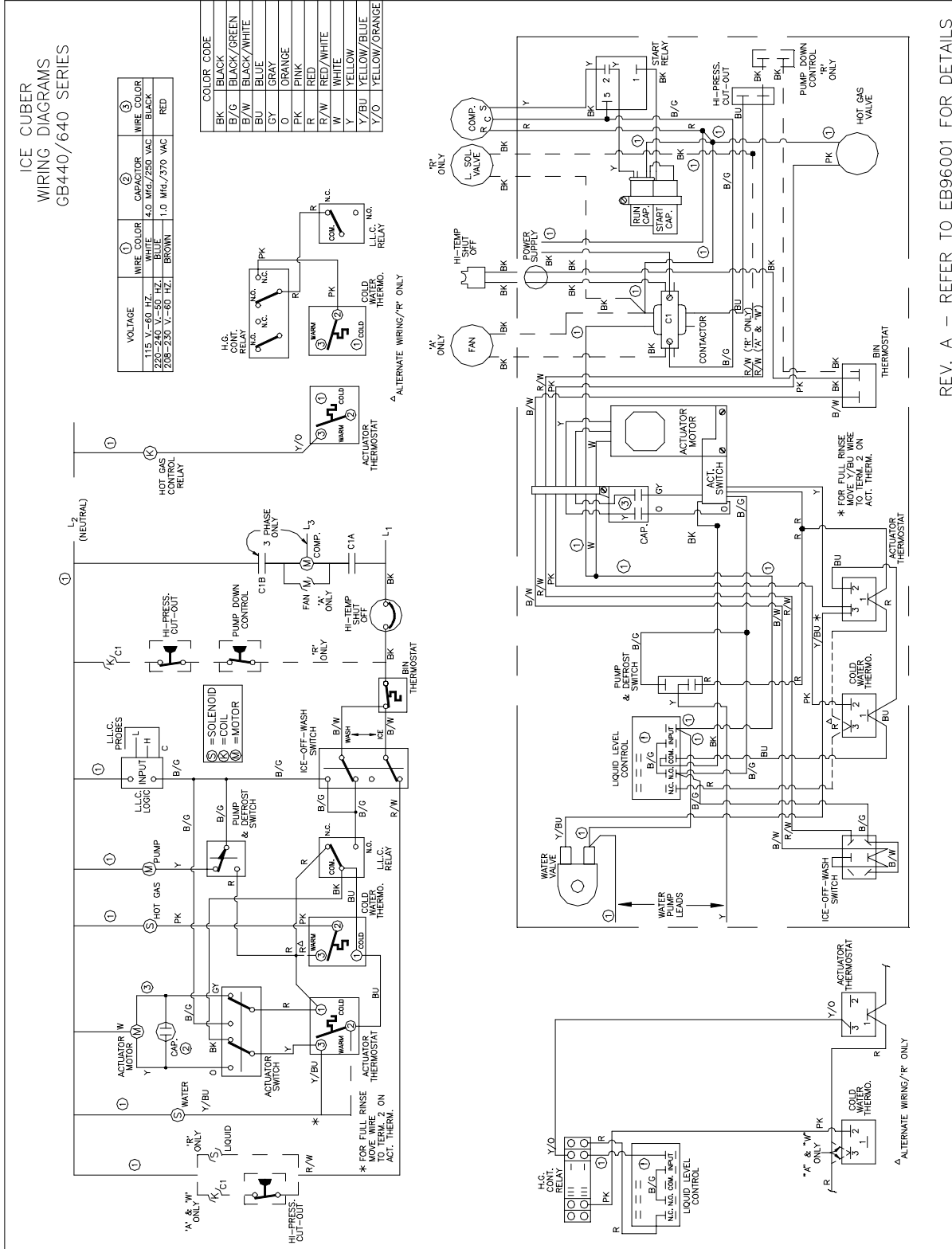

REV. A — REFER TO EB96001 FOR DETAILS

Wiring Diagrams

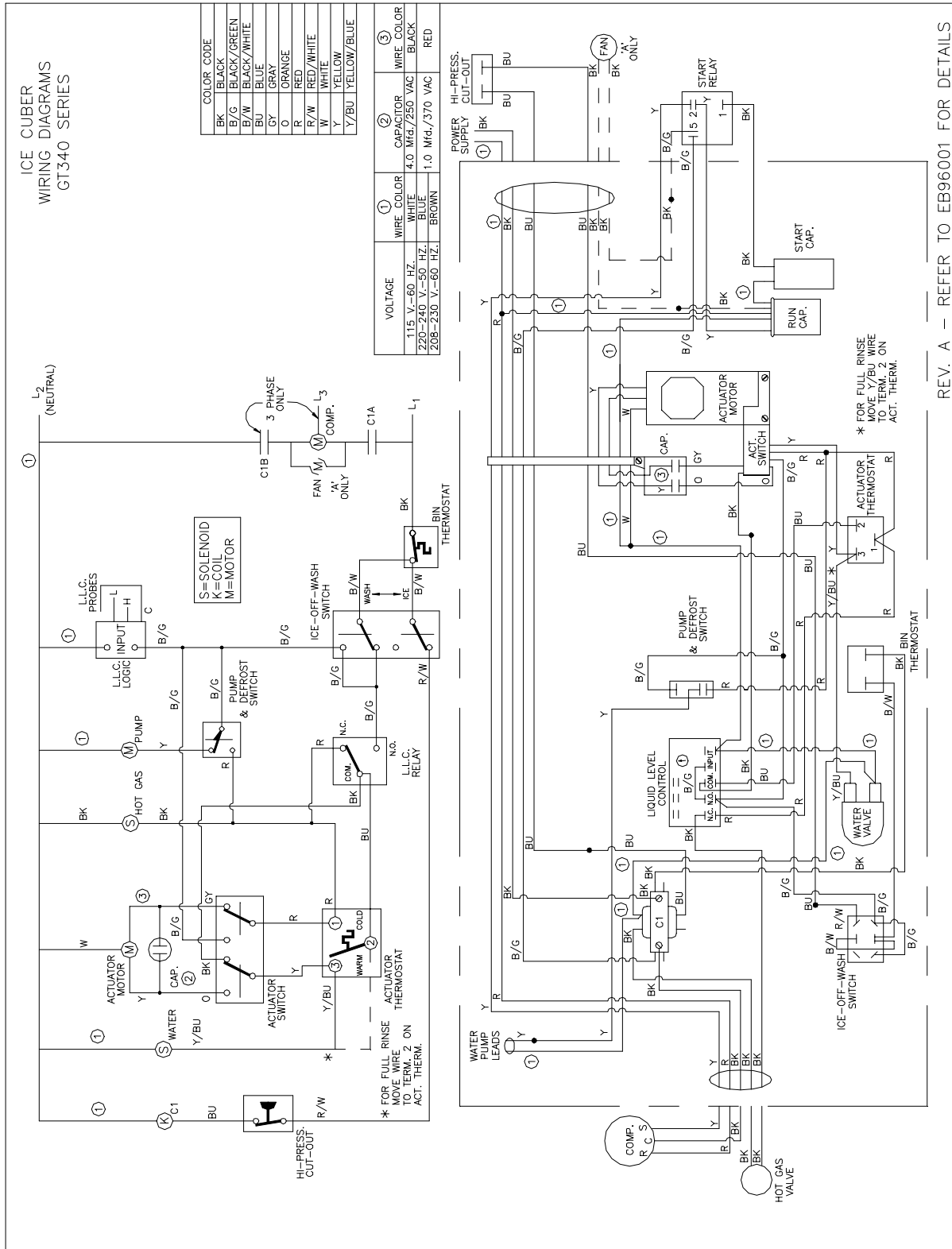

Wiring Diagrams

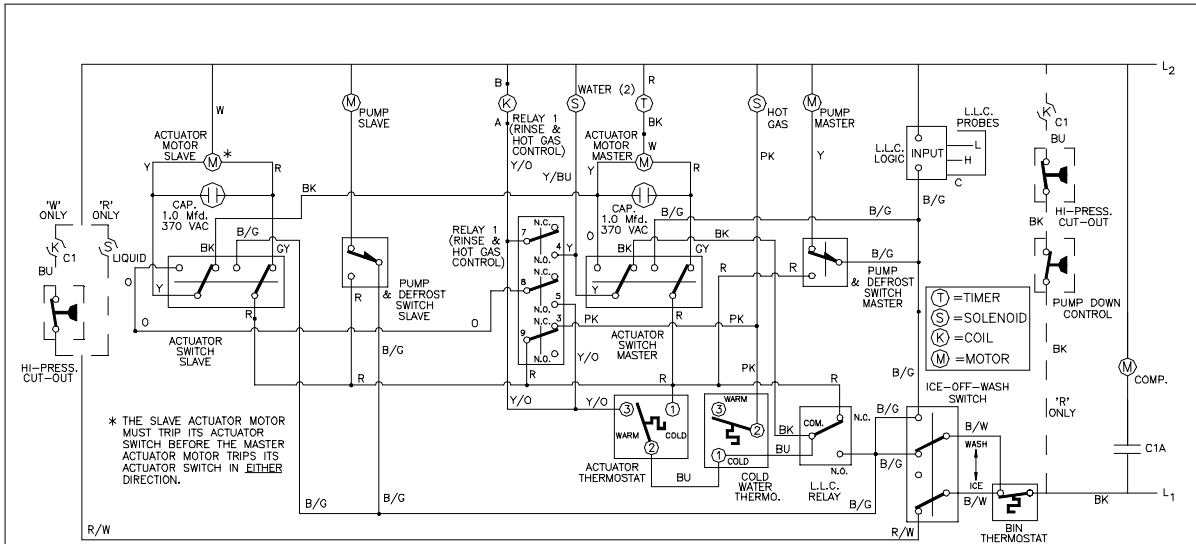

MASTER ELECTRICAL BOX

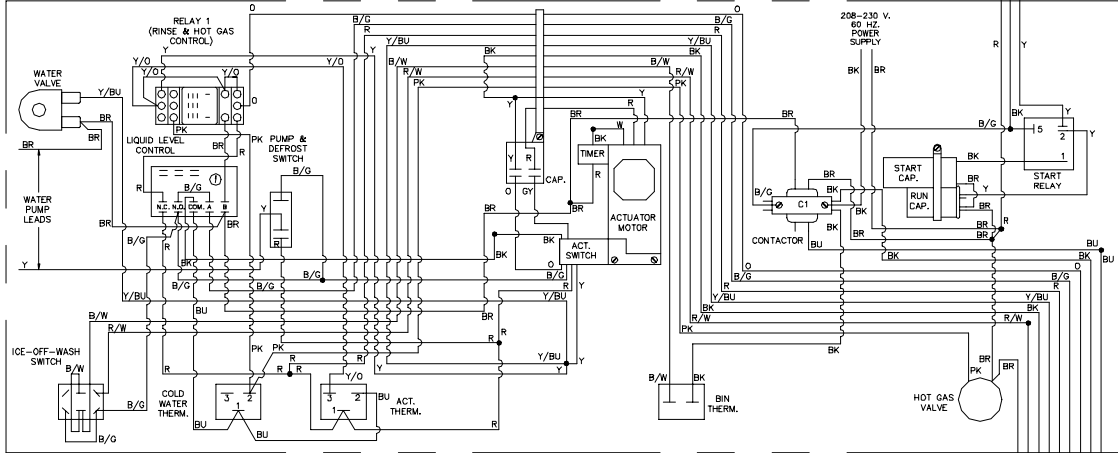

SLAVE ELECTRICAL BOX

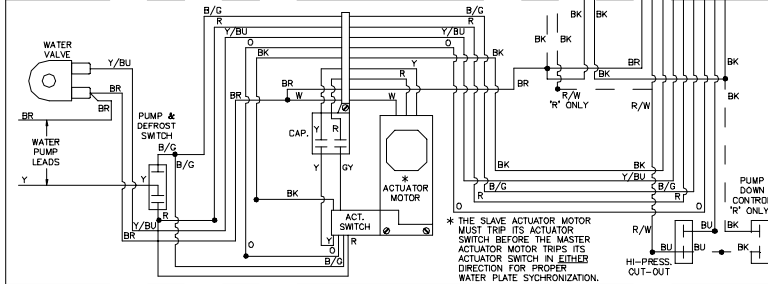

COLOR CODE	
BK	BLACK
B/G	BLACK/GREEN
B/W	BLACK/WHITE
BR	BROWN
BU	BLUE
GY	GRAY
O	ORANGE
PK	PINK
R	RED
R/W	RED/WHITE
W	WHITE
Y	YELLOW
Y/BU	YELLOW/BLUE
Y/O	YELLOW/ORANGE

REV. A - REFER TO EB96001 FOR DETAILS
 REV. B - DRAWING CORRECTION

ICE CUBER
 WIRING DIAGRAMS
 GB1244

SEE ENG. BULLETINS #96003, & 97001 FOR WIRING UPGRADES

Wiring Diagrams

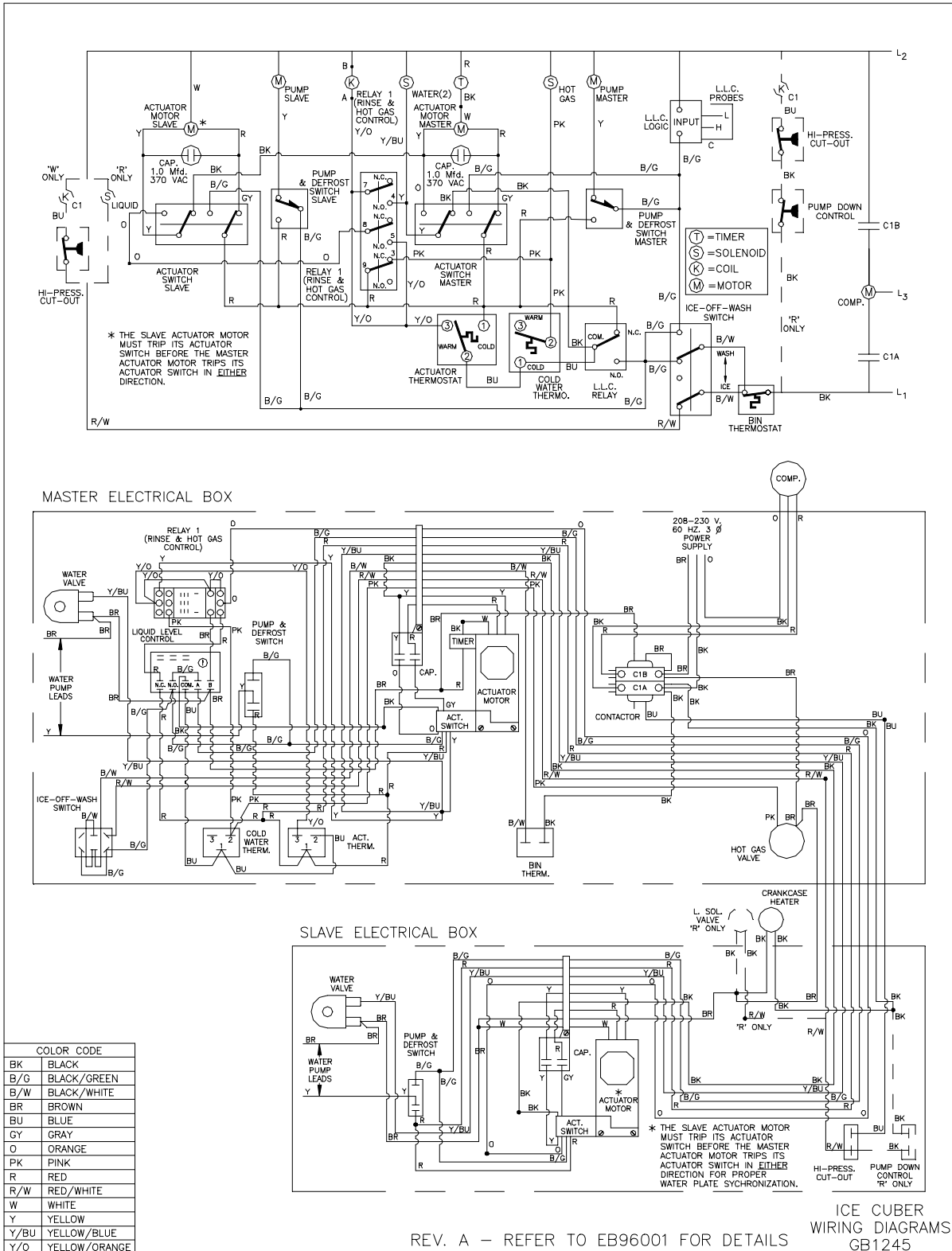

SEE ENG. BULLETINS #96003, & 97001 FOR WIRING UPGRADES

Wiring Diagrams

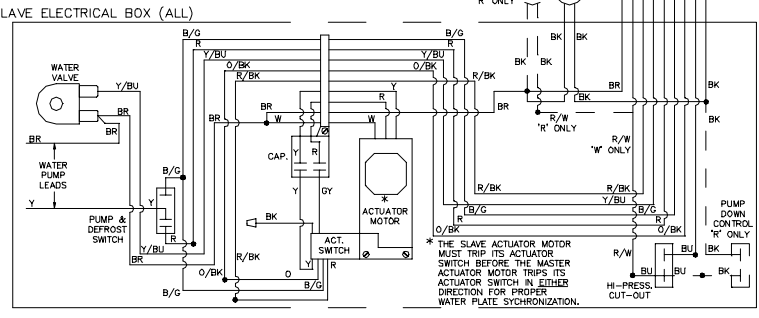
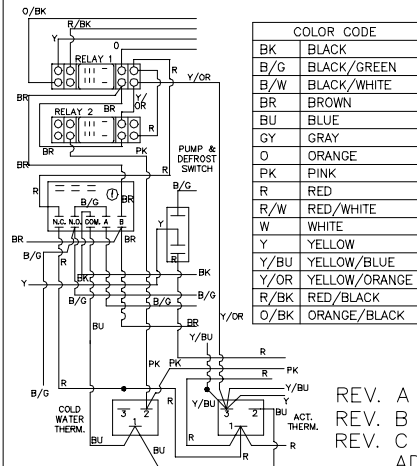
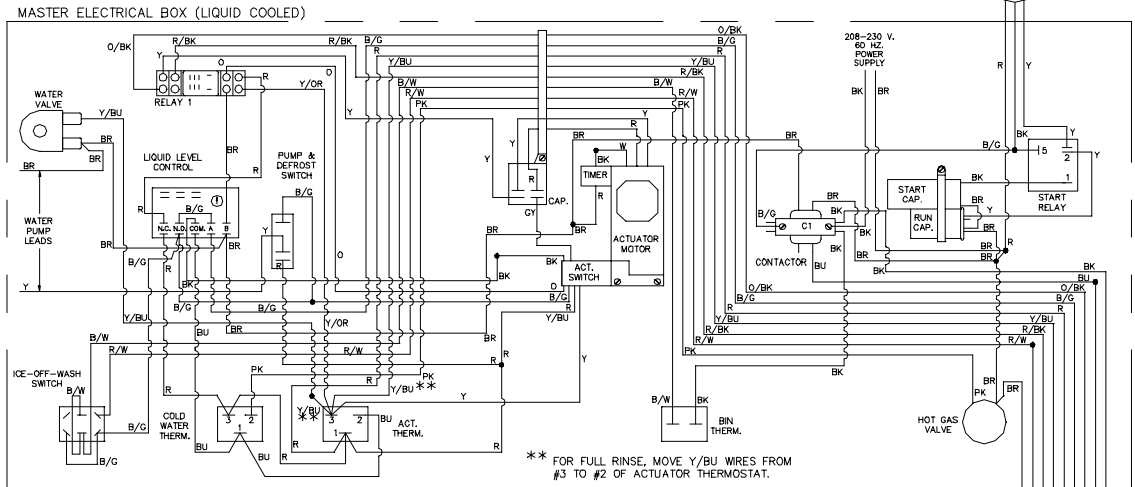
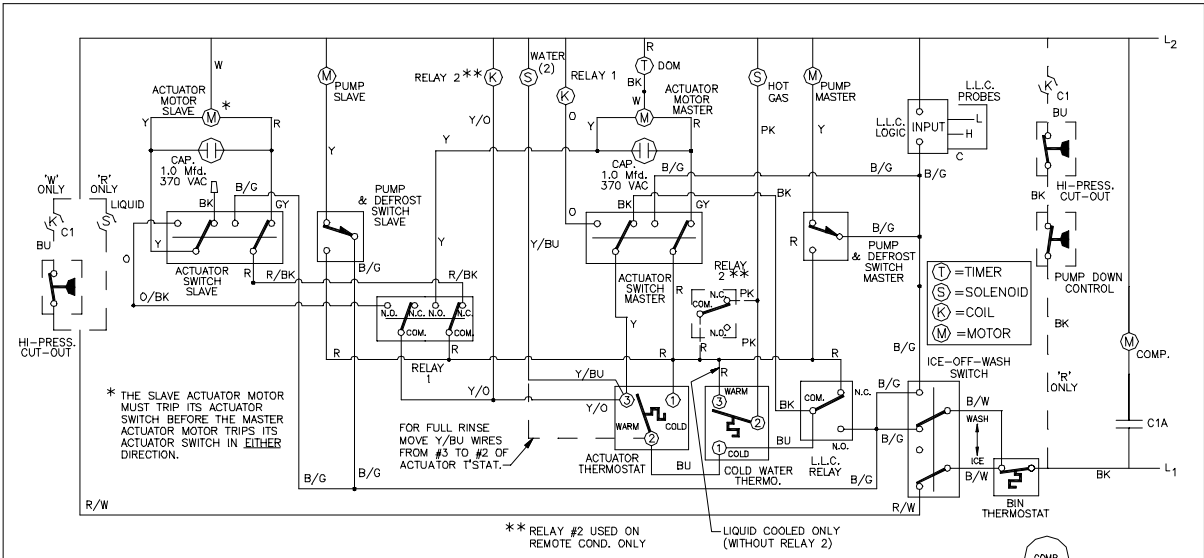

REV. A - REFER TO EB96001 FOR DETAILS
 REV. B - DRAWING CORRECTION
 REV. C - RELAY #1 FROM THREE POLE TO TWO POLE.
 ADD RELAY #2 FOR REMOTE COND. APPLICATION.

ICE CUBER
 WIRING DIAGRAMS
 GB1244

SEE ENG. BULLETIN #97001 FOR WIRING UPGRADE

Wiring Diagrams

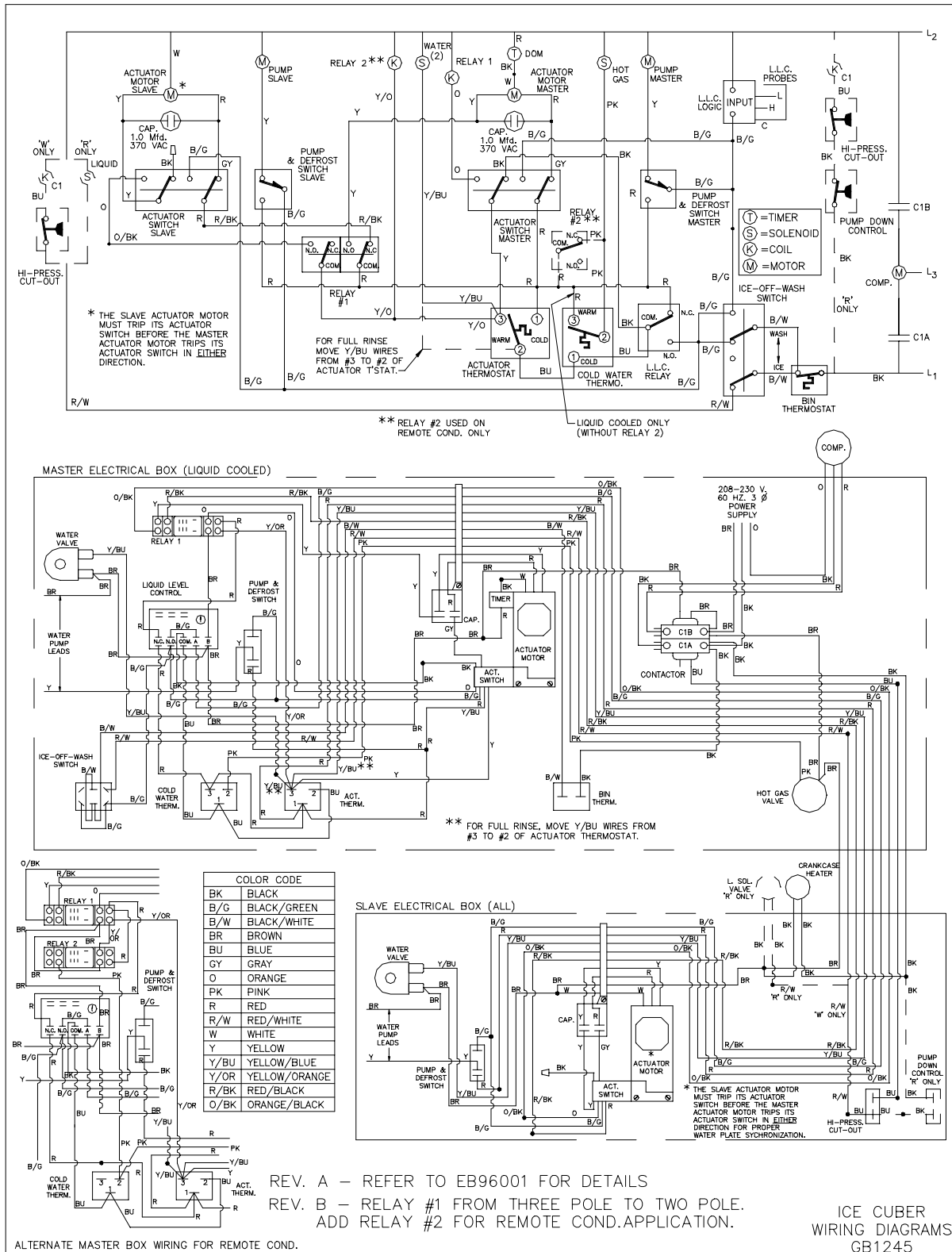

SEE ENG. BULLETIN #97001 FOR WIRING UPGRADE

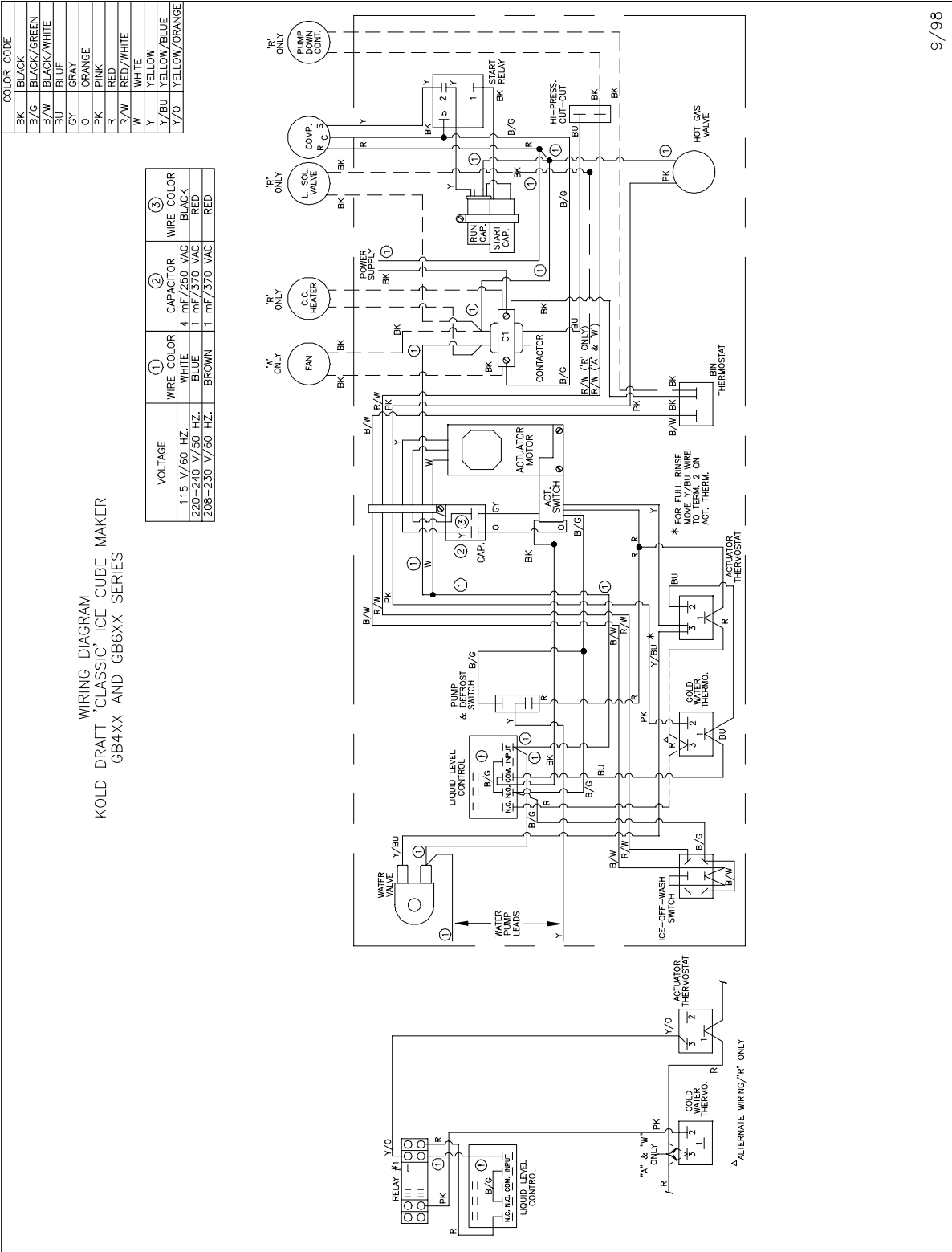

Wiring Diagrams

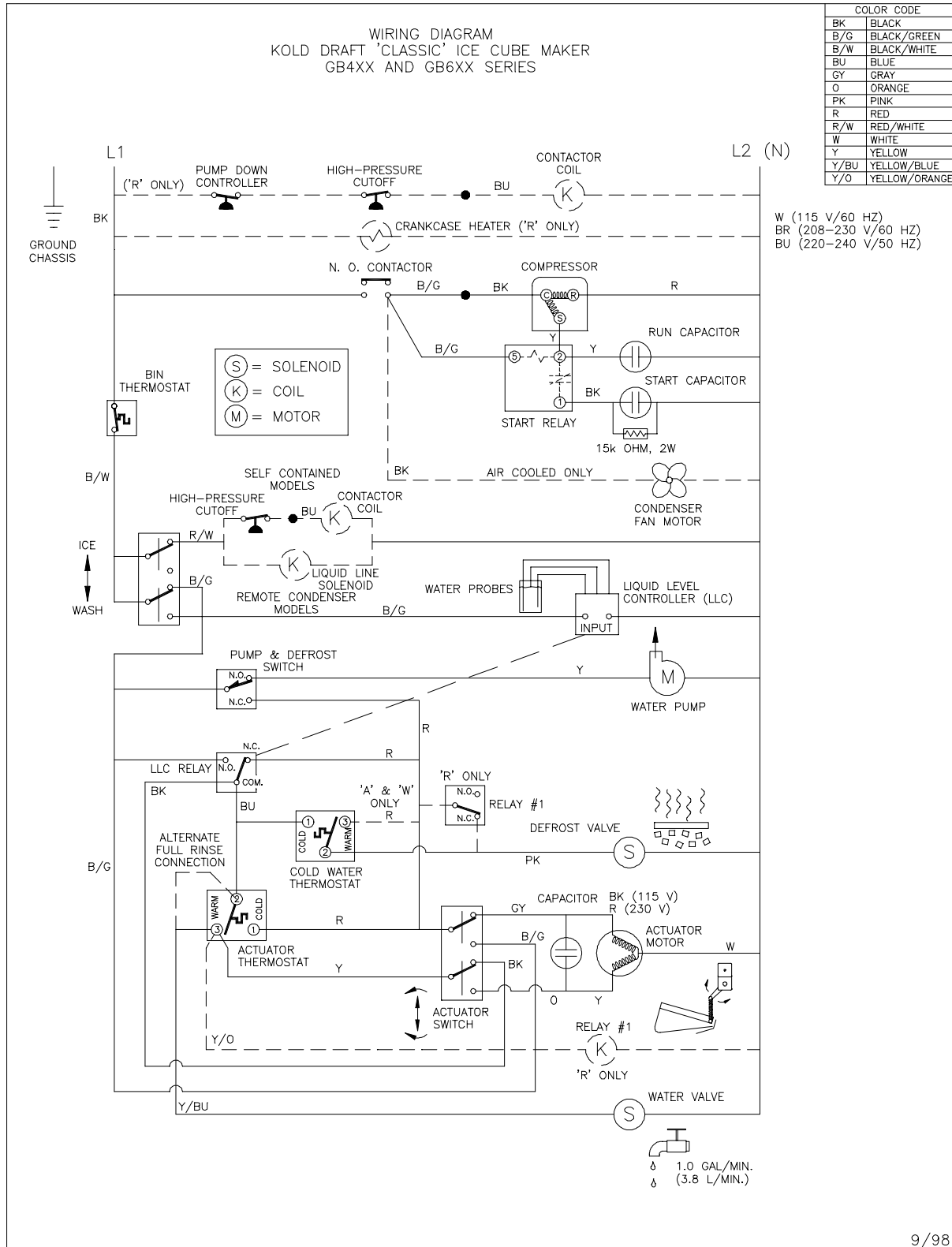

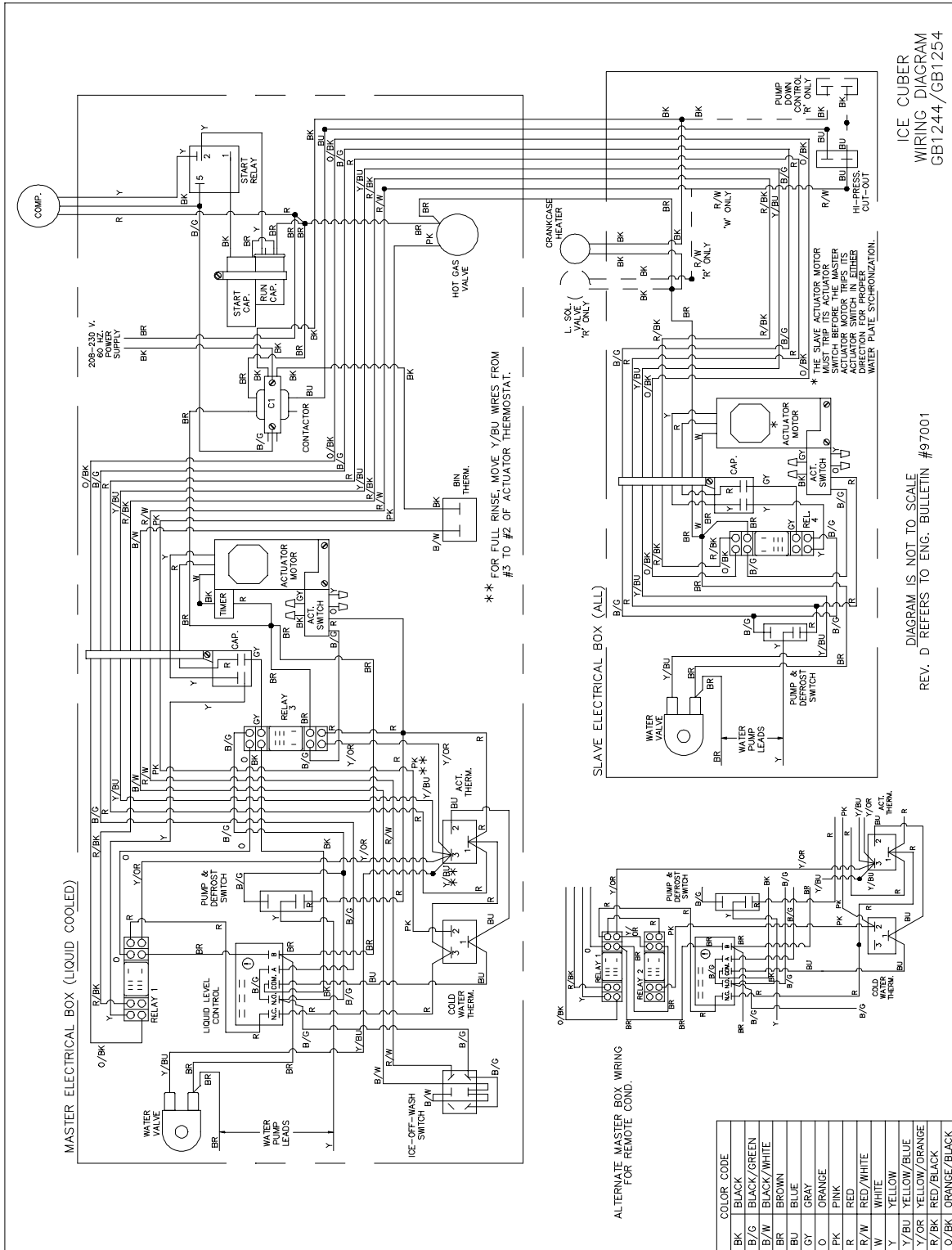

ICE CUBER
WIRING DIAGRAM
GB1244/GB1254

DIAGRAM IS NOT TO SCALE
REV. D REFERS TO ENG. BULLETIN #97001

Wiring Diagrams

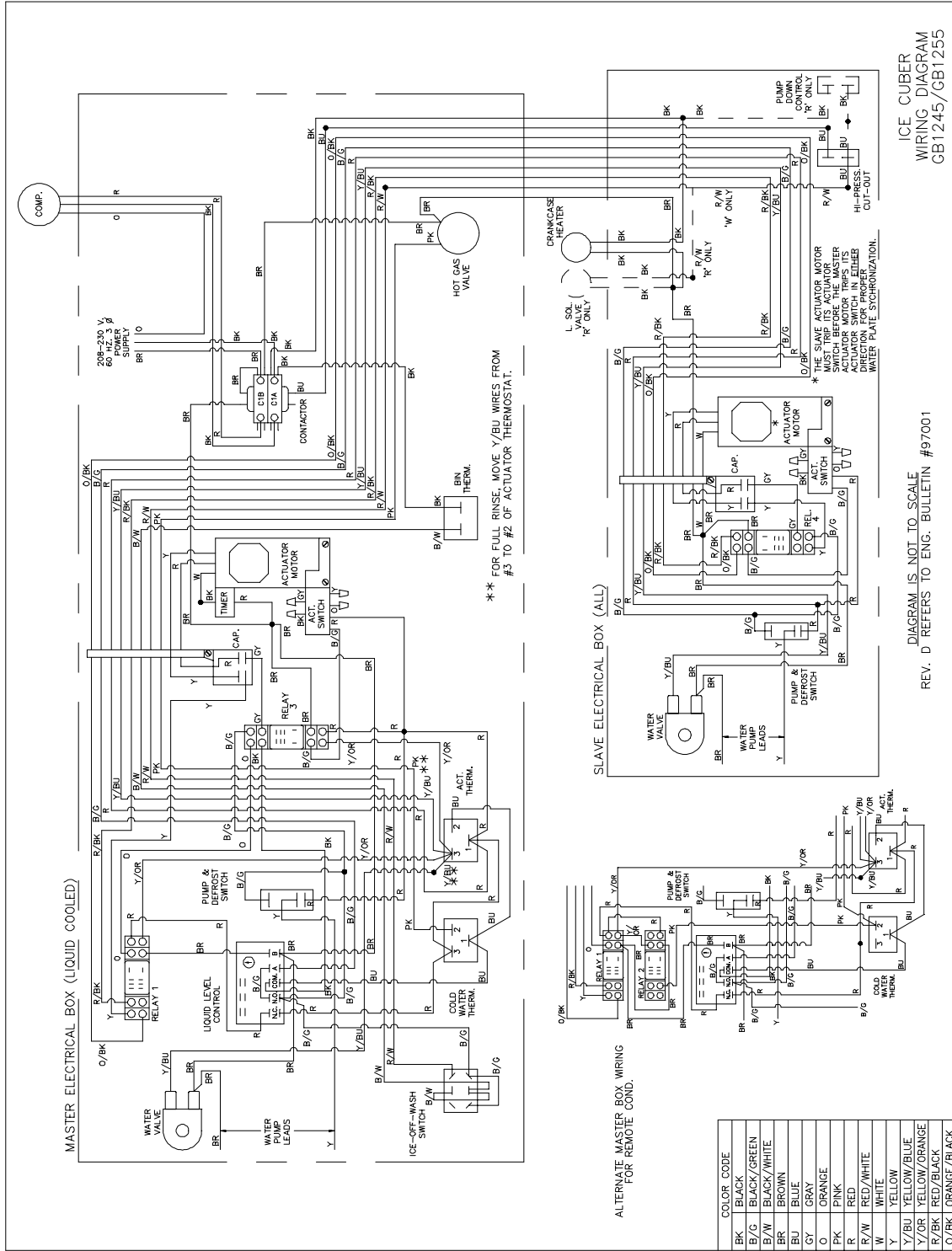

ICE CUBER
WIRING DIAGRAM
GB1245/GB1255

DIAGRAM IS NOT TO SCALE
REV. D REFERS TO ENG. BULLETIN #97001

Wiring Diagrams

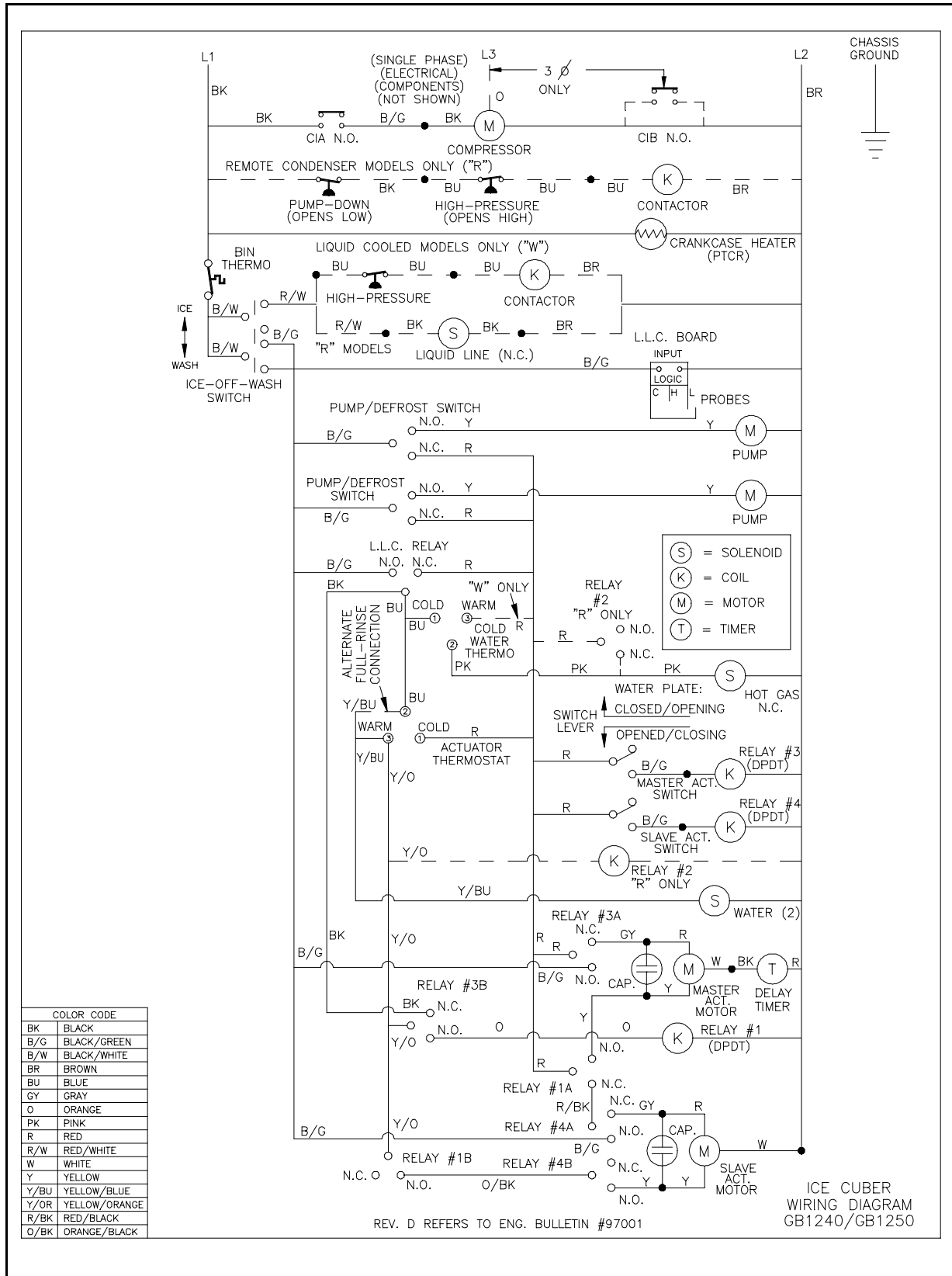

Wiring Diagrams

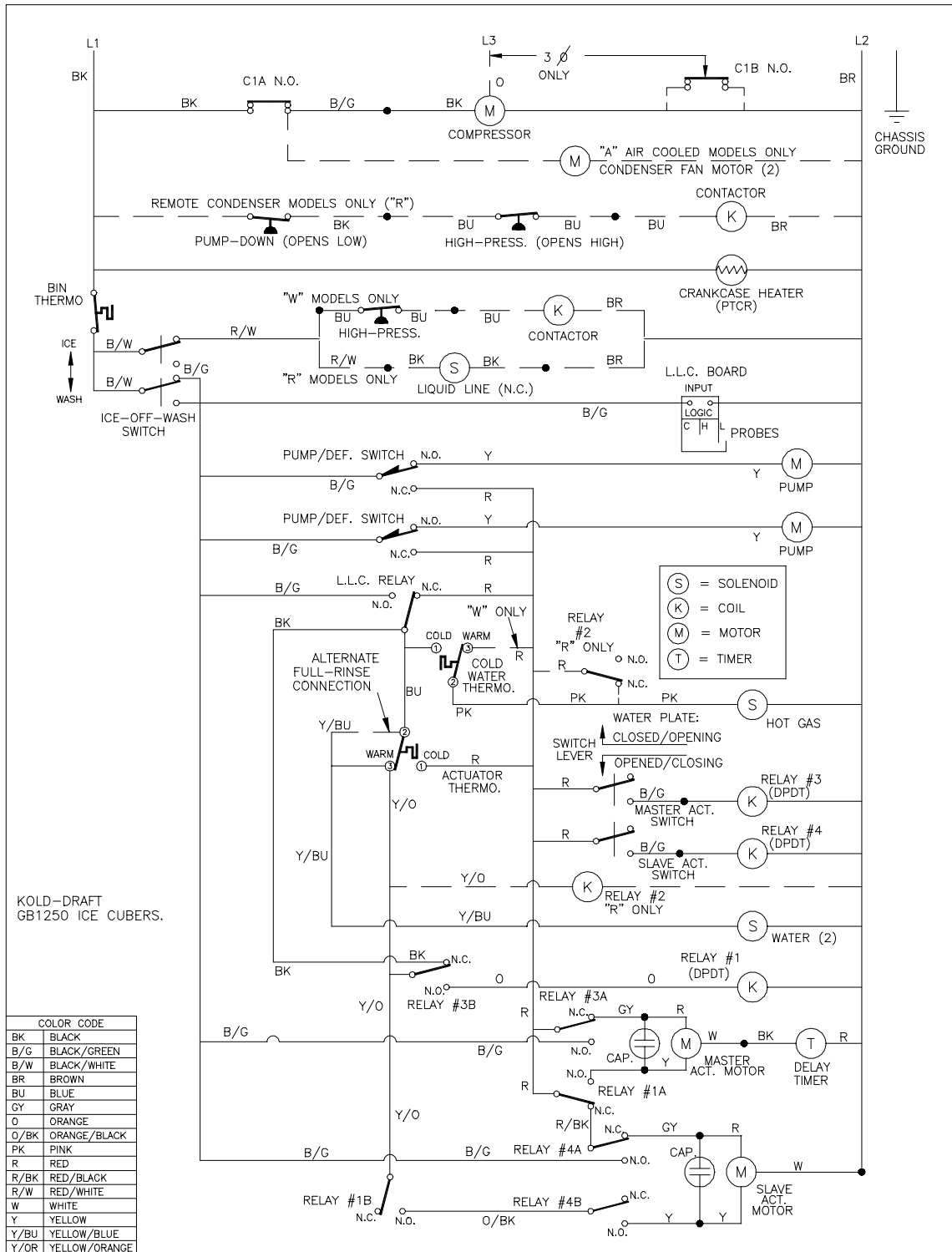

New 5/16/03

Wiring Diagrams

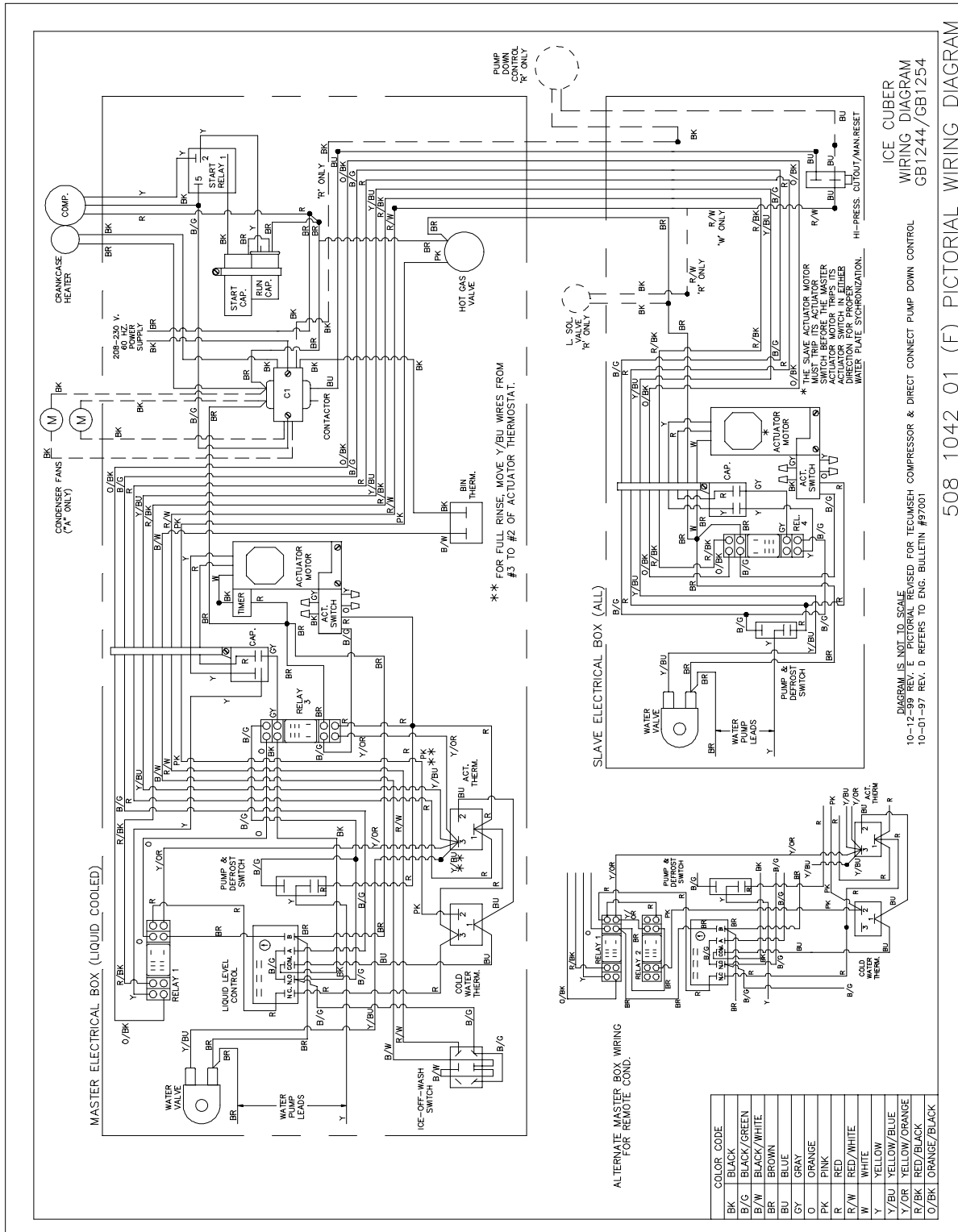

508 1042 01 (F) PICTORIAL WIRING DIAGRAM

New 5/16/03

Wiring Diagrams

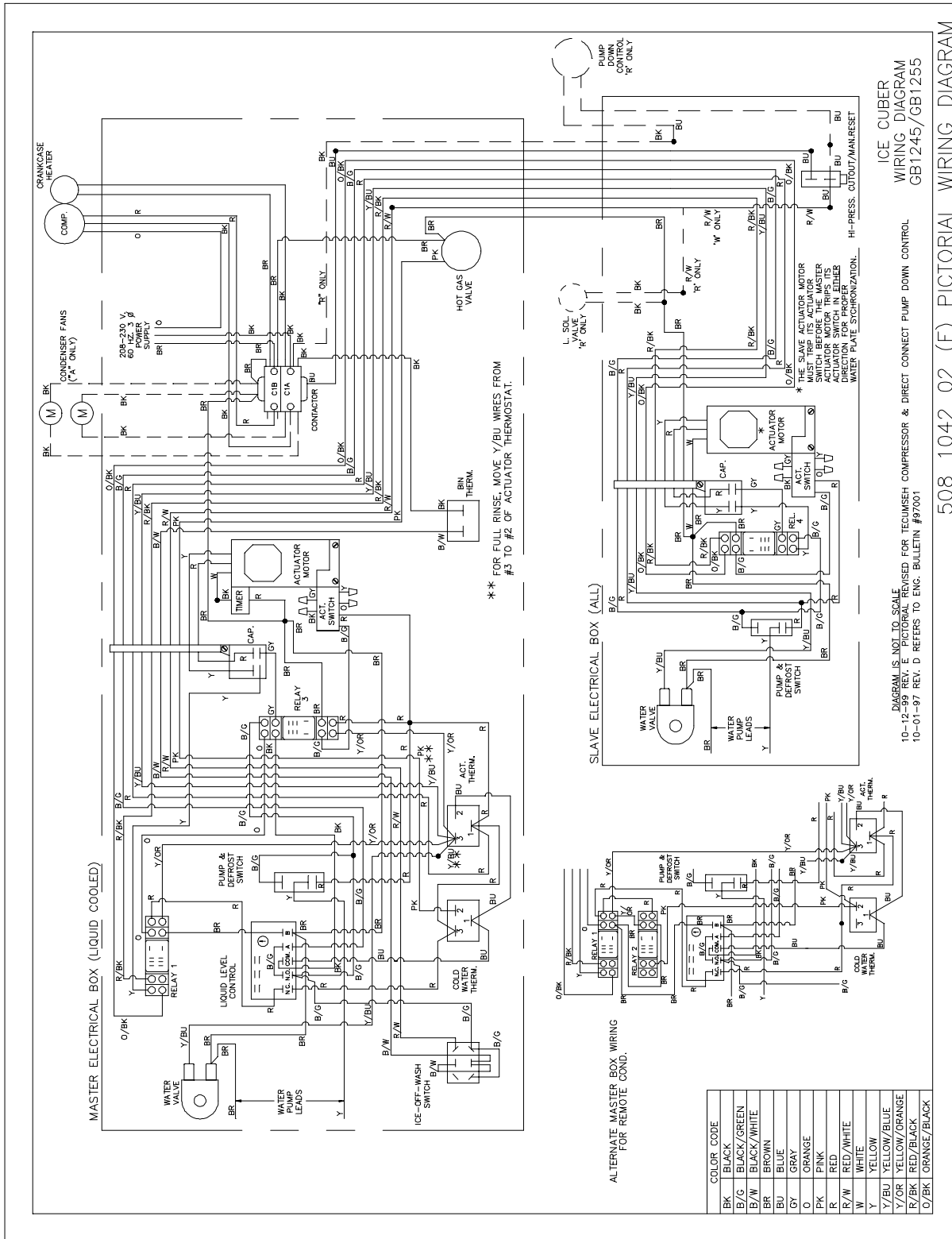

ICE CUBER
 WIRING DIAGRAM
 GB1245/GB1255

FOR TECHNISEH COMPRESSOR & DIRECT CONNECT PUMP DOWN CONTROL
 HI-PRESS. OUTPUT/MAN-RESET
 WATER PUMP MOTOR

508 1042 02 (F) PICTORIAL WIRING DIAGRAM

New 5/16/03

Wiring Diagrams

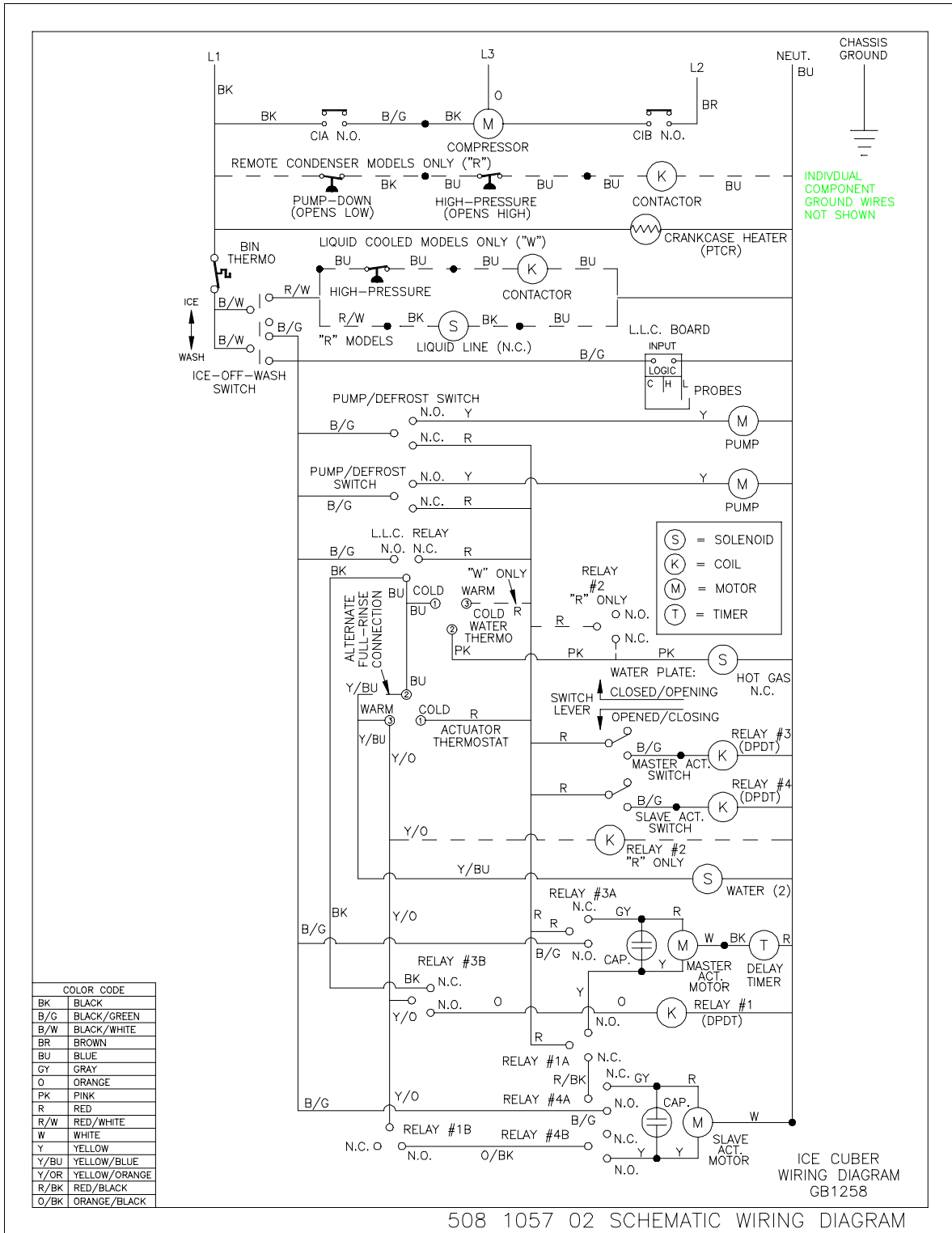

New 5/16/03

Wiring Diagrams

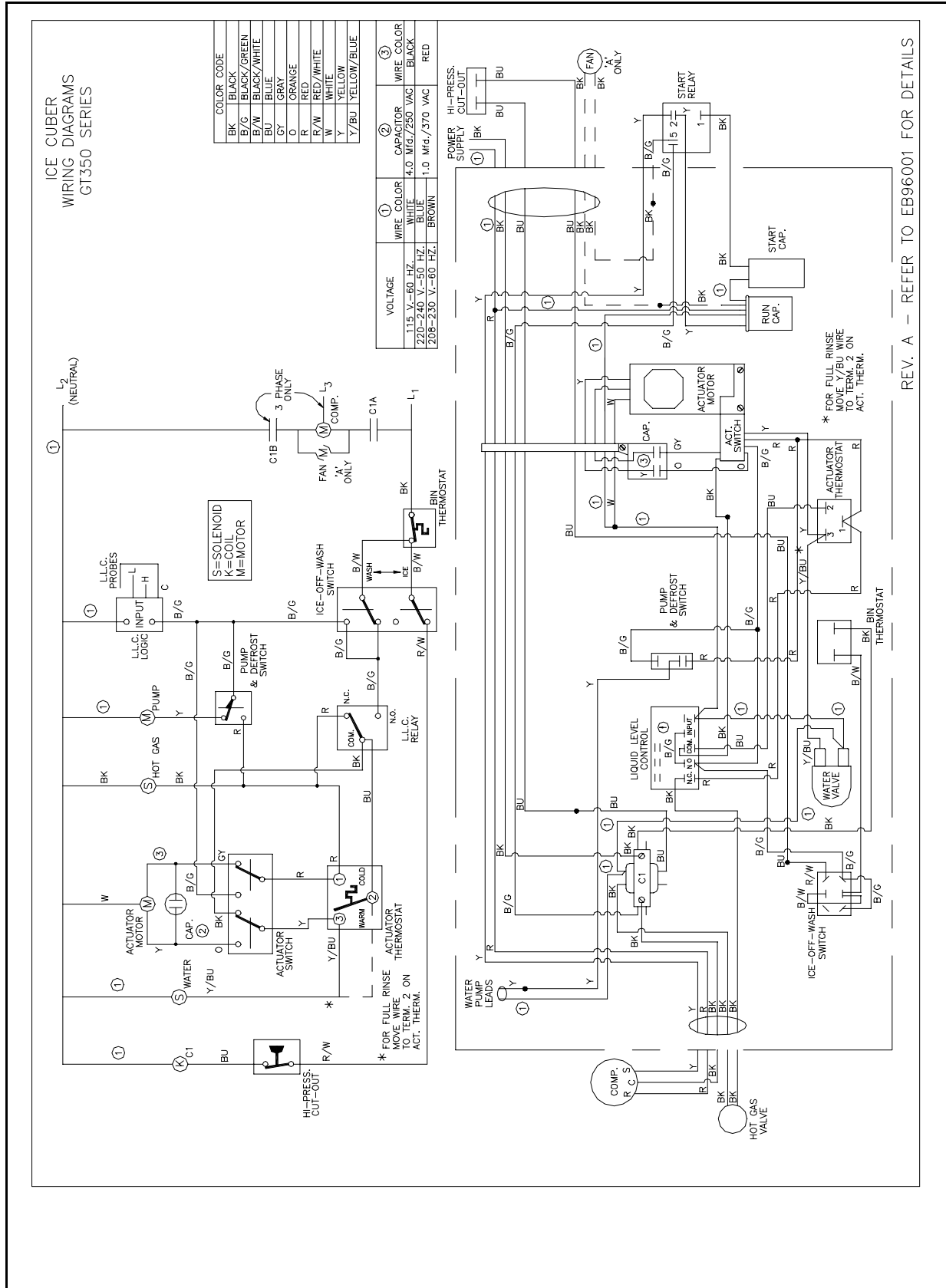

Wiring Diagrams

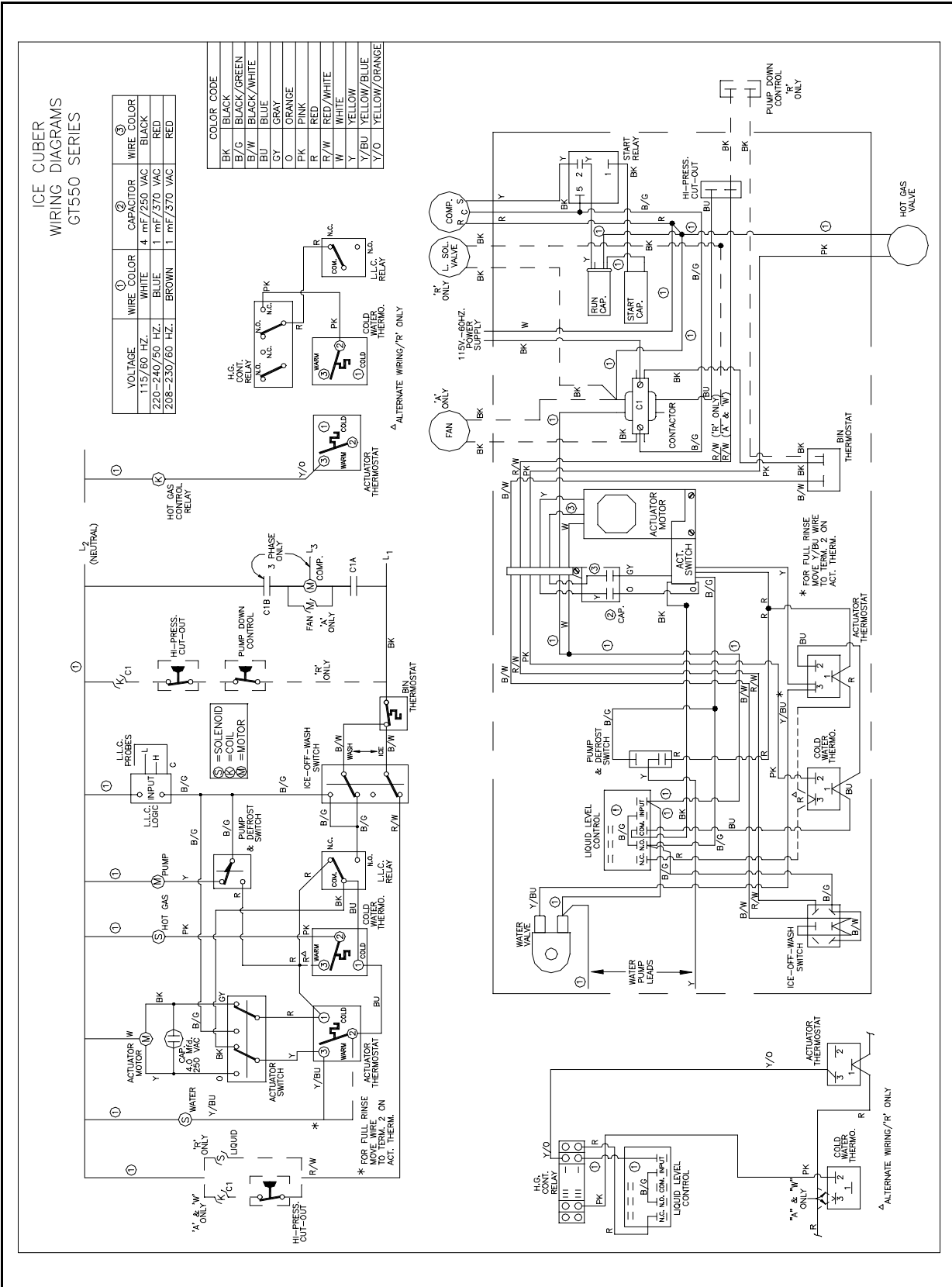

T-25X/T-26X Crusher Installation Instructions

CHECK FOR FREIGHT DAMAGE BEFORE PROCEEDING: Even though damage to the carton may not have been evident, check for hidden damage and contact freight carrier immediately if necessary to file a claim.

THIS EQUIPMENT MUST BE INSTALLED IN COMPLIANCE WITH THE APPLICABLE FEDERAL, STATE/PROVINCE AND/OR LOCAL PLUMBING, ELECTRICAL AND HEALTH/SANITATION CODES AND REQUIREMENTS.

CAUTION:

- ◆ RISK OF PERSONAL INJURY, PROPERTY DAMAGE, EQUIPMENT FAILURE OR FIRE.
- ◆ Refer all maintenance to qualified personnel.
- ◆ Never operate this equipment with covers, panels or other parts removed or not properly secured.
- ◆ Warn all users to clean up spillage immediately, keep storage bin doors closed, and report any apparent leakage or unusual sounds to maintenance personnel.
- ◆ Proper installation must include **Kold-Draft®** GR Series Ice Cuber mounted

Installation

NOTE: Refer to ice cuber instructions before proceeding.

1. Position the ice storage bin maintaining the minimum clearances specified in the cuber instructions.

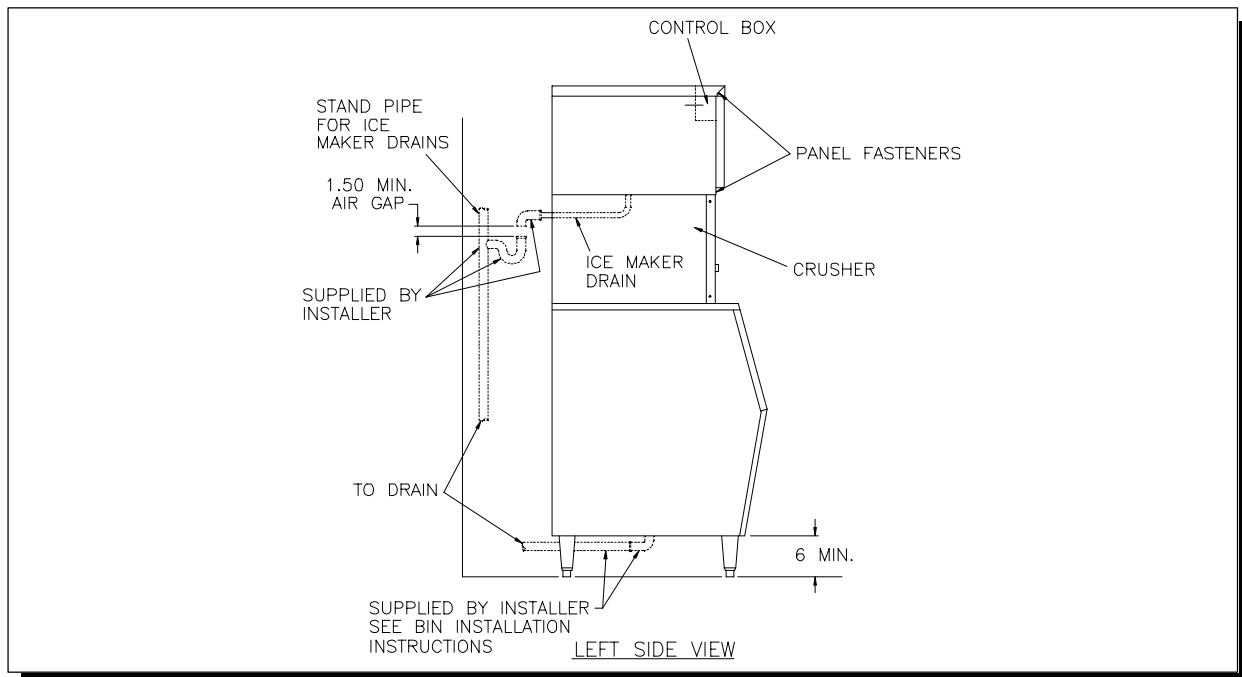

T-25X/T-26X Crusher Installation

2. Level the bin with adjusters on legs, or by shimming if the bin is to be sealed to the floor. If gaps due to shims are greater than 1/8 inch, install a cove molding around the bin bottom. Seal the bin or molding to the floor with NSF Certified RTV sealant (Dow-Corning RTV 732 or equal).
3. Install gasketing on top of bin if required. Gasket material must be positioned so that it extends to the outside edge of the perimeter of the crusher chassis when the crusher is in place.
4. **CAREFULLY** lift the crusher out of the carton and place onto the gasketed bin. Remove the front cover and note the alignment of the mounting holes in the chassis if mounting means are provided on the bin. Follow the bin installation instructions for securing the crusher to the bin. (**NOTE:** The selector knob must be removed before the front cover can be removed.)

CAUTION:

- ◆ RISK OF PERSONAL INJURY OR EQUIPMENT DAMAGE.
- ◆ Use a suitable lifting means and be careful of sharp edges.

5. Electrical and drain locations are shown below. All dimensions are in inches.

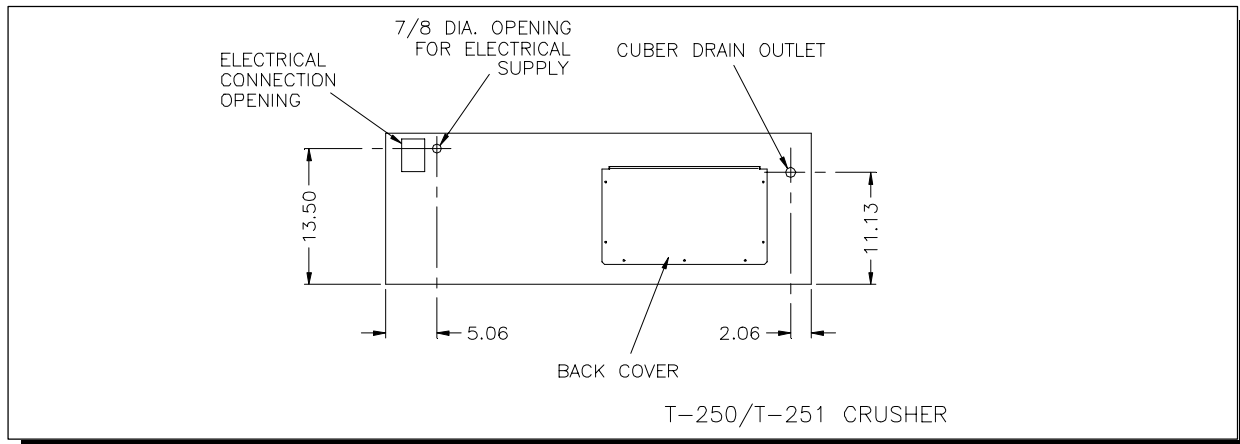

6. If a knockout is not provided, punch an 1-3/32 inch dia. hole in the ice maker condensing unit pan for the crusher control wiring. (See Illustration "A")

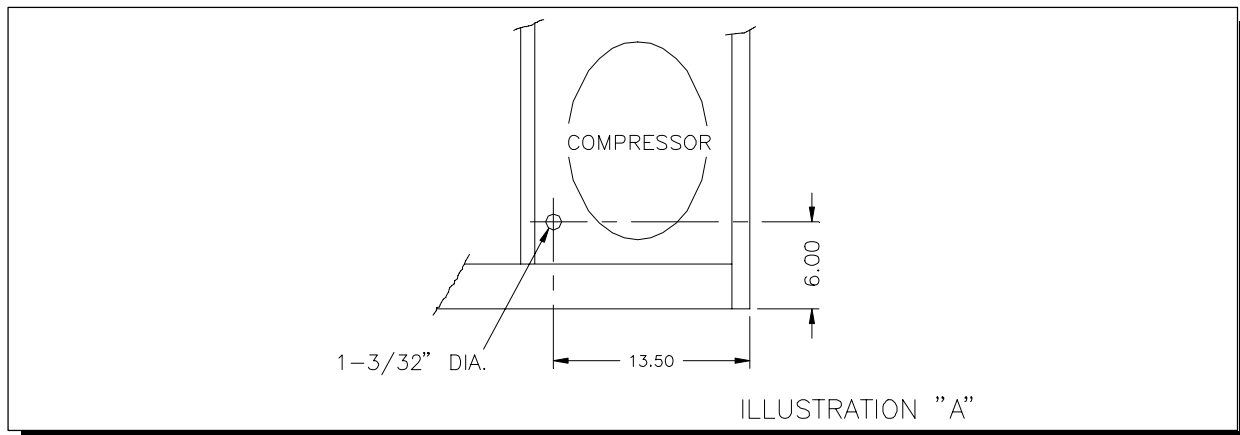

T-25X/T-26X Crusher Installation Instructions

7. Install gasketing on top of crusher. (See Illustration "B")

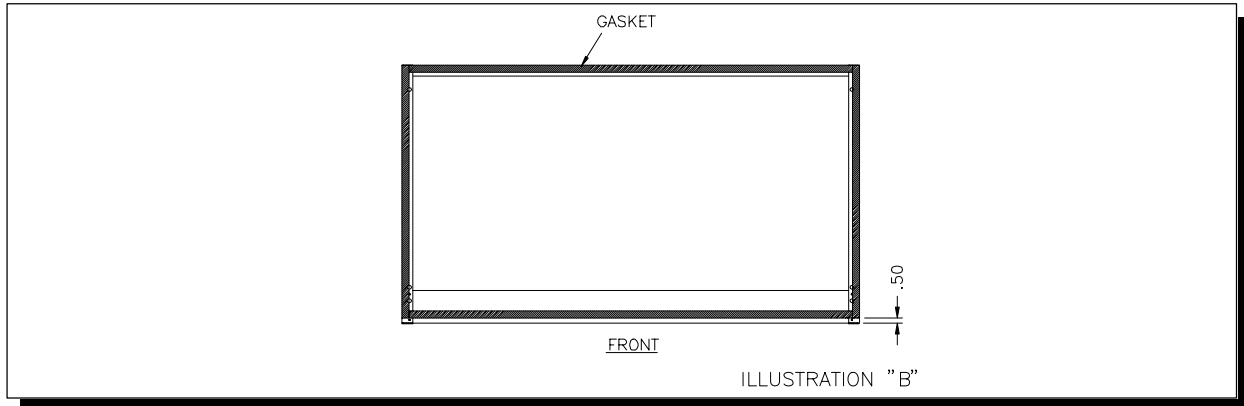

8. Remove the cuber cabinet panels, lift and position cuber on top of gasketed crusher and align mounting holes. Install cap screws, lockwashers and nuts. (See Illustration "C") **CAUTION:** Support cuber until all fasteners are secured.

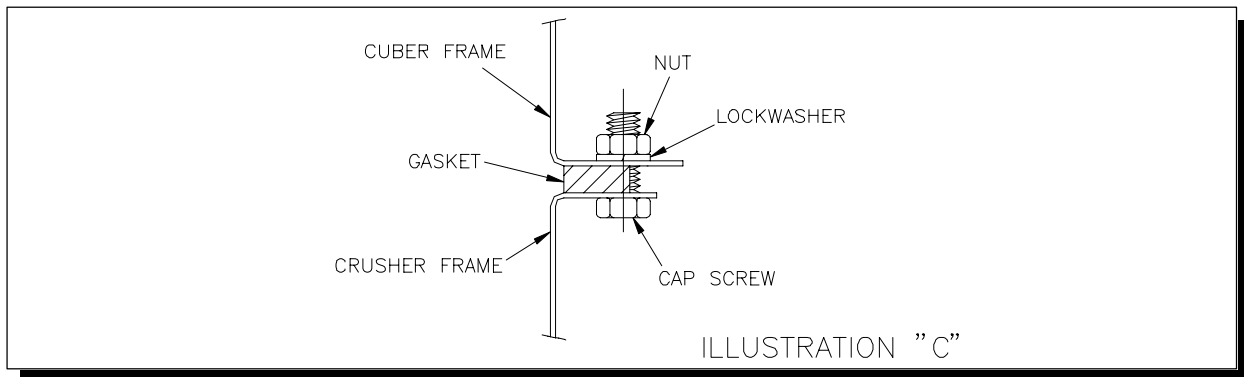

9. The crusher is designed to operate in conjunction with one or two **Kold-Draft®** cubers. Two motor control relay blocks are provided and a relay coil must be installed for each cuber used. Each relay coil must have a voltage rating matching the voltage of the ice cuber, regardless of the crusher motor voltage. The relay

coils are installed through the opening in the control box, by the installer, and are ordered separately. A third relay is provided for controlling one or two cubers with the same set of bin thermostats. This relay coil voltage rating is matched to the crusher motor voltage and is provided with the crusher.

10. A dual safety switch system is employed in the crusher design to break the circuit to the motor. If either the front panel of the crusher or the front panel of the bottom ice maker is removed, a switch will open the motor circuit. The crusher safety switch is mounted in the crusher control box. The ice maker safety switch

CAUTION:

- ◆ The safety switches **DO NOT** de-energize all circuits in the crusher or any circuits in the ice maker. Before cleaning or servicing this equipment, disconnect all power supplies.

T-25X/T-26X Crusher Installation

must be mounted by the installer. (See Illustration "D") If not provided, locate and drill two 3/16 inch dia. holes in the ice maker lower front rail. Mount the safety switch support with the #8-32 screws and nuts provided.

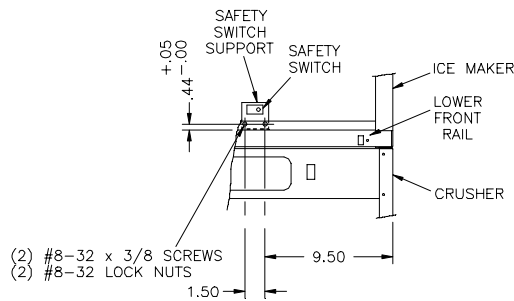

ILLUSTRATION "D"

11. Install a grommet in the 1-3/32 inch dia. hole in the ice maker condensing unit pan. Push the crusher control wire assemblies through the grommet into the ice maker.
12. Connect the safety switch wires from the crusher to the "Common" and "Normally Open" terminals of the cuber safety switch. (See Wiring Diagram)
13. Route the crusher control wires along the right side of the partition wall to a 7/8 inch hole located to the right of the contactor. Install a grommet in the hole and push the wires through.
14. The bin thermostat in the cuber must be disabled and replaced by the two thermostatic switches in the crusher. (See Wiring Diagram)
15. The crushed ice thermostat (left) cap tube is placed into the straight thermostat tube holder. Push the cap tube into the flared end until the cap tube is visible at the straight end. Install the tube holder into the hole in the motor platform directly behind the crusher motor.
16. The cube ice thermostat (right) cap tube is placed into the bent thermostat tube holder. Mount the tube holder as shown. (See Illustration "E") Tighten clamp screws. Adjust thermostats to shut off the cuber approximately 1 minute after ice contacts the tube holders.

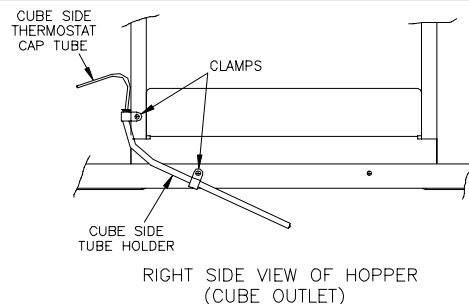

ILLUSTRATION "E"

CAUTION:

- ◆ Route bin thermostat cap tubes away from moving parts.

T-25X/T-26X Crusher Installation Specifications

INSTALLATION SPECIFICATIONS

The T-250 and T-264 are wired at the factory for 200-240 volt 50/60 hz. operation. The T-251 and T-261 are wired for 100-120 volt 50/60 hz. operation.

CAUTION:

- ◆ Risk of property damage, equipment failure or fire. Comply with all installation specifications for safe operation.

Refer to equipment name plate data for current value and maximum fuse size. This unit must be provided with a separate, properly protected circuit with no other loads. A fused disconnect installed adjacent to the crusher is recommended (must be supplied by installer), and may be required by local codes.

Crushers are intended for indoor use only with permanent connection to a field electrical supply. All models are intended to be installed only in conjunction with **Kold-Draft**® cubers on **Kold-Draft**® bins.

CRUSHER OPERATION

With the crusher knob in the "CRUSHED" position, ice falling from the cuber will be directed by the selector plate through the crusher mechanism and deposited into the left side of the bin.

The crusher motor is powered through a relay which is energized by the red circuit of the ice maker. The selector knob must be in the "CRUSHED" position to close a switch and complete the circuit to the motor. Additionally, the front panel safety switches must be depressed (covers on) for motor operation.

With the crusher knob in the "CUBE" position, ice falling from the cuber will bypass the crusher mechanism and be dumped into the right side of the bin. The crusher motor will not be energized.

T-25X/T-26X Crusher Preventative

CRUSHER MAINTENANCE

Every 6 Months Minimum

CAUTION:

- ◆ Risk of personal injury, equipment damage or contamination of the ice bin.
- ◆ Do not use ammonia solutions or strong detergents in cleaning the crusher.
- ◆ Never use appliance polishes, finish preservatives or cleaners in areas that could contact ice.
- ◆ Disconnect power before cleaning or servicing unit.

CLEANING

Always clean the ice maker first, following the ice maker cleaning instructions.

Remove all ice from the bin before starting the cleaning procedure.

Clean and sanitize storage bin last.

1. Remove ice maker panels, ice chute, drain pan, crusher front panel and belt guard.
2. Wash interior with a solution of 2 tablespoons of baking soda per quart of clean water (140° F. max.). The crusher ice hopper can be accessed from the front and left side of the ice cuber. Use a long handled brush to clean inside the hopper, as crusher teeth can cause injury.
3. The bottom area of the crusher ice hopper can be accessed from inside the ice bin. Use a long handled brush.
4. Wipe down internal cabinet walls with a cloth soaked in cleaning solution.
5. Rinse with clean tap water.
6. Sanitize all ice contact surfaces with a solution of 1 teaspoon 5-1/4% sodium hypochlorite (chlorine bleach) per quart of clean tap water (minimum 100 PPM free chlorine). A spray bottle will facilitate this process.
7. Pour the remaining solution into the crusher chute, slowly, while rotating the cutter wheel by hand turning the pulley.
8. After adjusting and lubricating crusher (See following section), replace all enclosure panels and connect the electrical supply.
9. Exterior surfaces may be cleaned by standard methods suitable to the stainless steel finish.

ADJUSTMENT AND LUBRICATION

1. Oil the crusher motor (if ports are provided) and grease the shaft bearings. (Do not over-lubricate)
2. Check the belt and pulleys for excessive wear. Adjust the belt tension to deflect 5/32 inch with two pounds applied to the center of the span.
3. Tighten any loose set screws, machine screws, nuts and electrical connections.

AKD-125 Dispenser Installation Instructions

CHECK FOR FREIGHT DAMAGE BEFORE PROCEEDING: Even though damage to the carton may not have been evident, check for hidden damage and contact freight carrier immediately if necessary to file a claim.

THIS EQUIPMENT MUST BE INSTALLED IN COMPLIANCE WITH THE APPLICABLE FEDERAL, STATE/PROVINCE AND/OR LOCAL PLUMBING, ELECTRICAL AND HEALTH/SANITATION CODES AND REQUIREMENTS.

CAUTION:

- ◆ RISK OF PERSONAL INJURY, PROPERTY DAMAGE, EQUIPMENT FAILURE OR FIRE.
- ◆ Refer all maintenance to qualified personnel.
- ◆ Never operate this equipment with covers, panels or other parts removed or not properly secured.
- ◆ Warn all users to clean up spillage immediately, and report any apparent leakage or unusual sounds to maintenance personnel.
- ◆ Proper installation must include **Kold-Draft®** GT Series Ice Cuber mounted above Dispenser.

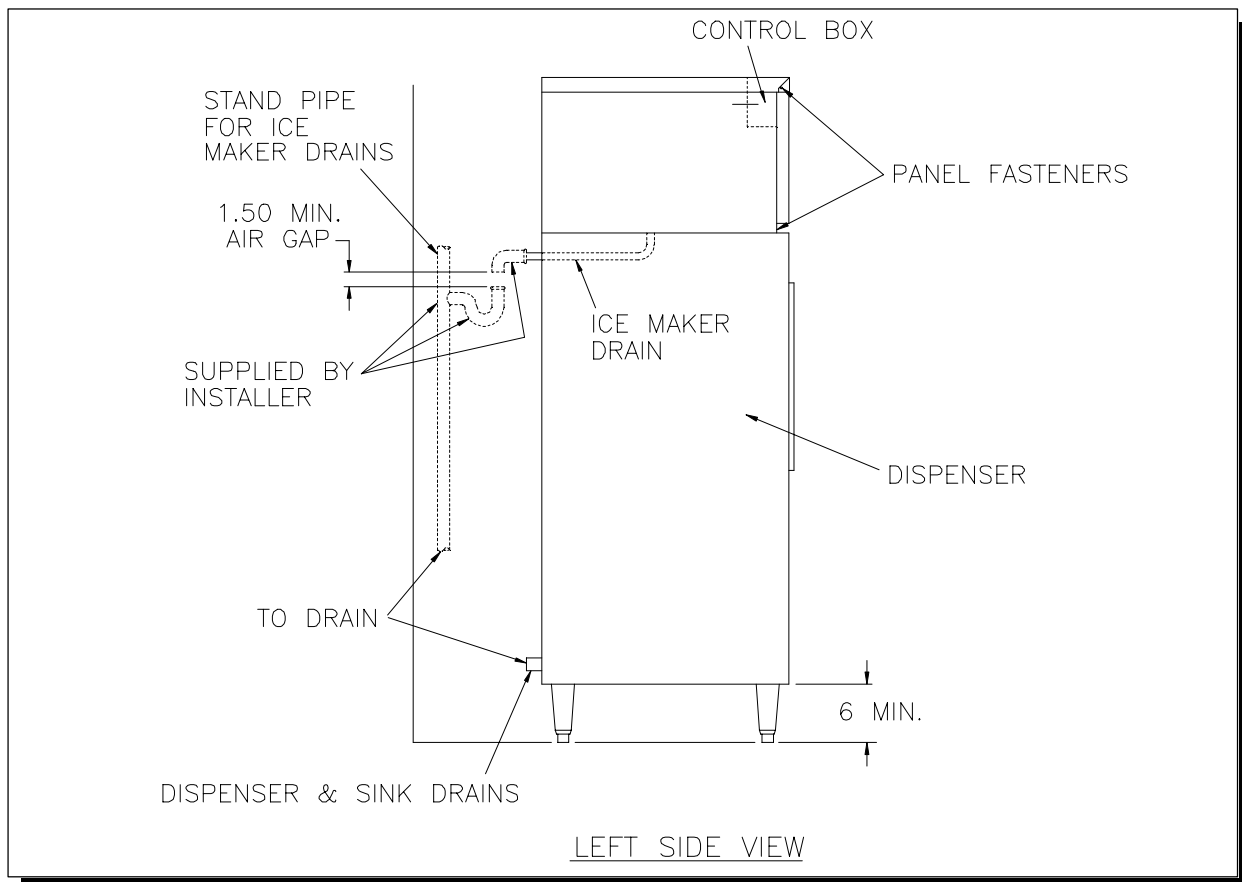

AKD-125 Dispenser Installation

Installation

NOTE: Refer to ice cuber instructions before proceeding.

1. **CAREFULLY** remove the carton from the dispenser.
2. If the dispenser is to be mounted on the 6" legs provided, carefully place the unit on its back and install the legs in the threaded mounting holes.
3. Position the dispenser maintaining the minimum clearances specified in the cuber instructions.
4. Level the dispenser by adjusting the legs, or by shimming if the unit is to be sealed to the floor. If gaps due to shims are greater than 1/8 inch, install a cove molding around the dispenser bottom. Seal the dispenser or molding to the floor with NSF Certified RTV sealant (Dow-Corning RTV 732 or equal).
5. Electrical and drain locations are shown below. All dimensions are in inches.

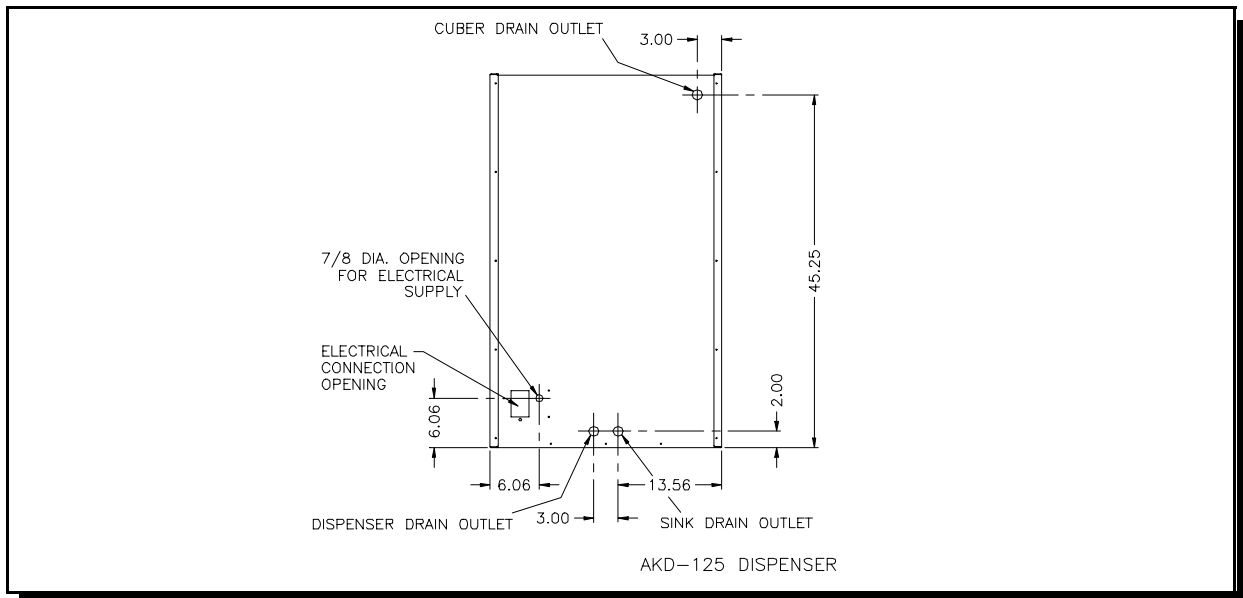

6. Install gasketing on top of dispenser. (See Illustration "A")

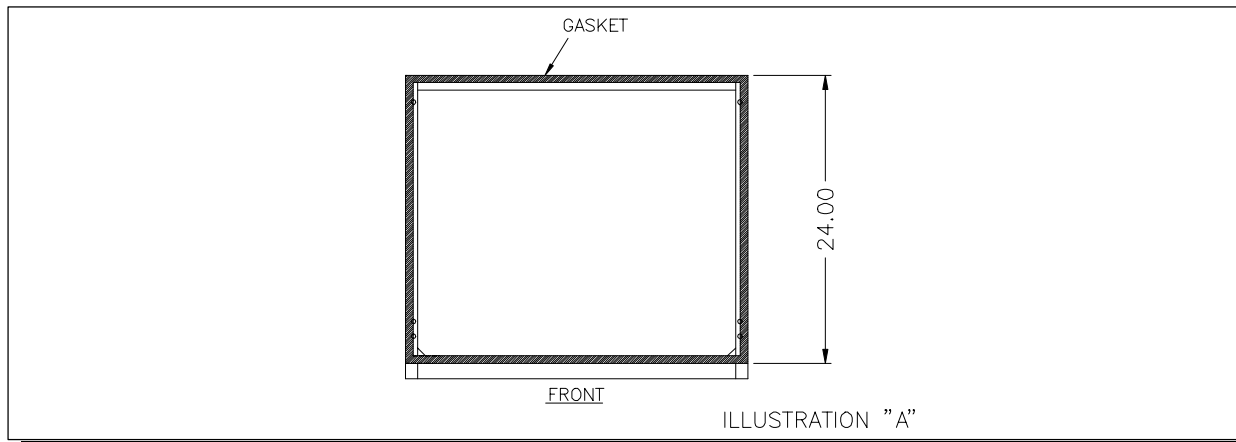

AKD-125 Dispenser Installation Instructions

7. Remove the cuber cabinet panels, lift and position cuber on top of gasketed dispenser and align mounting holes. Install 1/4"-20 stainless steel cap screws and lockwashers. **CAUTION:** support cuber until all fasteners are secure.
8. If the GT cuber, that you are mounting on the AKD, does not have the hole in the drain pan support, you must do the following:
 - A) Drill out the pop rivet, on the drain pan support that is nearest to the right side of the cuber, with a #27 (.144" dia.) drill.
 - B) Attach the bracket to the drain pan support with the s.m. screw provided.
 - C) Slide the S.S. tube through the hole in the bracket.
 - D) Run the bin thermostat cap tube along the right side of the cabinet, then into the S.S. tube. Allow the tip of the cap tube to protrude slightly past the end of the S.S. tube (See Illustration "B")

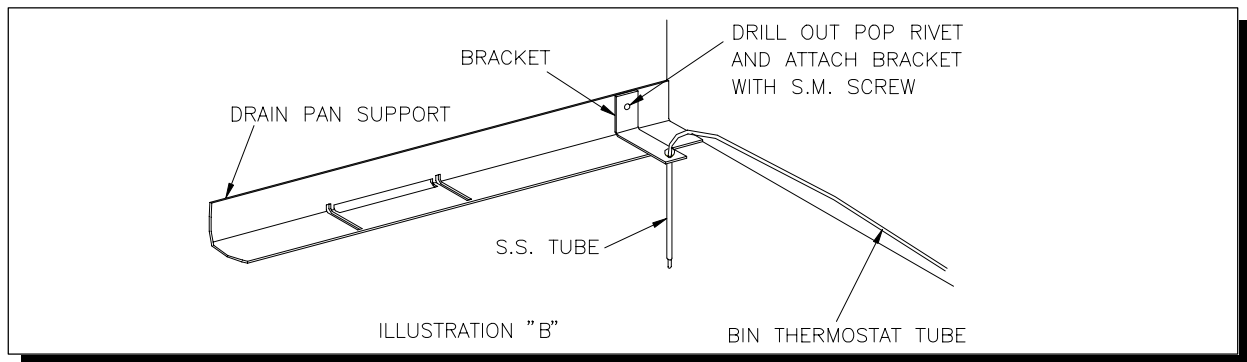

9. If the GT cuber has the hole in the drain pan support, then slide the S.S. tube through the hole in the drain pan support, route the bin thermostat cap tube along the right side of the cabinet and through the S.S. tube (See Illustration "C"). Allow the tip of the cap tube to protrude slightly past the end

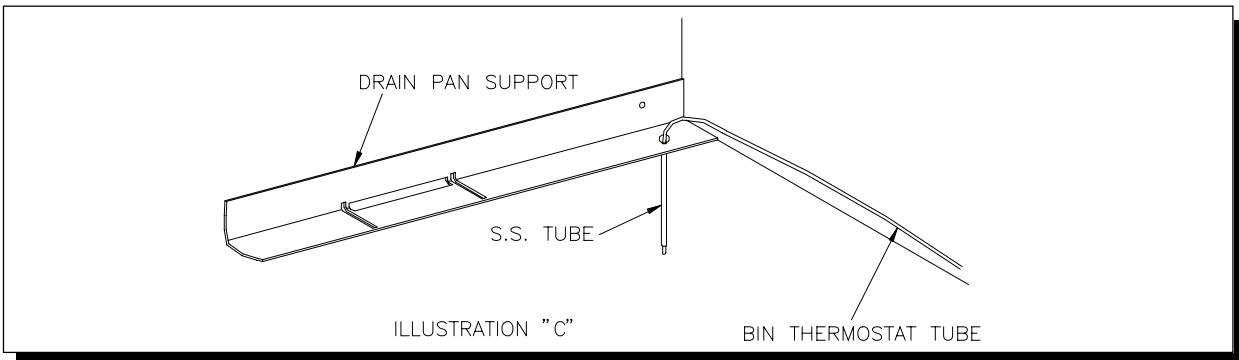

CAUTION:

- ◆ Route bin thermostat cap tube away from moving parts.

AKD-125 Dispenser Installation

INSTALLATION SPECIFICATIONS

The AKD-125 Ice Dispenser is designed for 115 volt 60 hz. operation

CAUTION:

- ◆ Risk of property damage, equipment failure or fire. Comply with all installation specifications for safe operation.

Refer to equipment name plate data for current value and maximum fuse size. This unit must be provided with a separate, properly protected circuit with no other loads. A fused disconnect installed adjacent to the dispenser is recommended (to be supplied by installer), and may be required by local codes.

This Dispenser is intended for indoor use only with permanent connection to a field electrical supply. This model is intended to be installed only in conjunction with a **Kold-Draft®** cuber.

AKD-125 Dispenser Preventative Maintenance

DISPENSER MAINTENANCE

Every 6 Months Minimum

CAUTION:

- ◆ Risk of personal injury, equipment damage or contamination of the dispenser bin.
- ◆ Do not use ammonia solutions or strong detergents in cleaning the dispenser.
- ◆ Never use appliance polishes, finish preservatives or cleaners in areas that contact ice.
- ◆ Disconnect power before cleaning or servicing unit.

CLEANING

Always clean the ice maker first, following the ice maker cleaning instructions.

Remove all ice from the dispenser before starting the cleaning procedure.

1. Remove ice maker top and front panels and drain pan/chute.
2. Loosen the wing nuts on the upper bearing clamp and pull it off to release the top of the auger.
3. Pull the auger up at least 1" on its axis to clear the lower drive mechanism and remove it through the front of the ice maker.
4. Wash the bin interior with a solution of 2 tablespoons of baking soda per quart of clean water (140° F. max.). The dispenser bin can be accessed through the front of the ice maker. Use a long handled brush to reach the bottom of the bin if needed.
5. Wash the sink interior with the baking soda solution and wipe dry with a clean cloth. **NOTE:** The spout and spout closure should be removed for thorough cleaning in the solution container and then replaced.
6. Rinse with clean tap water.
7. Replace the auger, making sure that it is fully engaged with the lower drive mechanism. Install the upper bearing clamp and tighten the wing nuts.
8. Sanitize all ice contact surfaces including the ice spout and spout closure with a solution of 1 teaspoon 5-1/4% sodium hypochlorite (chlorine bleach) per quart of clean tap water (minimum 100 PPM free chlorine). A spray bottle will facilitate this process. Pour the unused sanitizing solution over the auger and down the storage area drain.
9. Exterior surfaces may be cleaned by standard methods suitable to the stainless steel finish.
10. Replace the ice maker front and top panels before reconnecting the power supply.

Wiring Diagram

ICE CRUSHER WIRING DIAGRAMS T-250/T-251 SERIES T-261/T-264 SERIES

ICE MAKER VOLTAGE	WIRE COLOR
115 V.-60 HZ.	WHITE
220-240 V.-50 HZ.	BLUE
208-230 V.-60 HZ.	BROWN

COLOR CODE
BK
B/W
BU
BR/W/BU
R
Y
Y/GR

MODEL	ELECTRICAL RATING
T250	200-240V/50-60HZ.
T251	100-120V/50-60HZ.
T261	100-120V/50-60HZ.
T264	200-240V/50-60HZ.

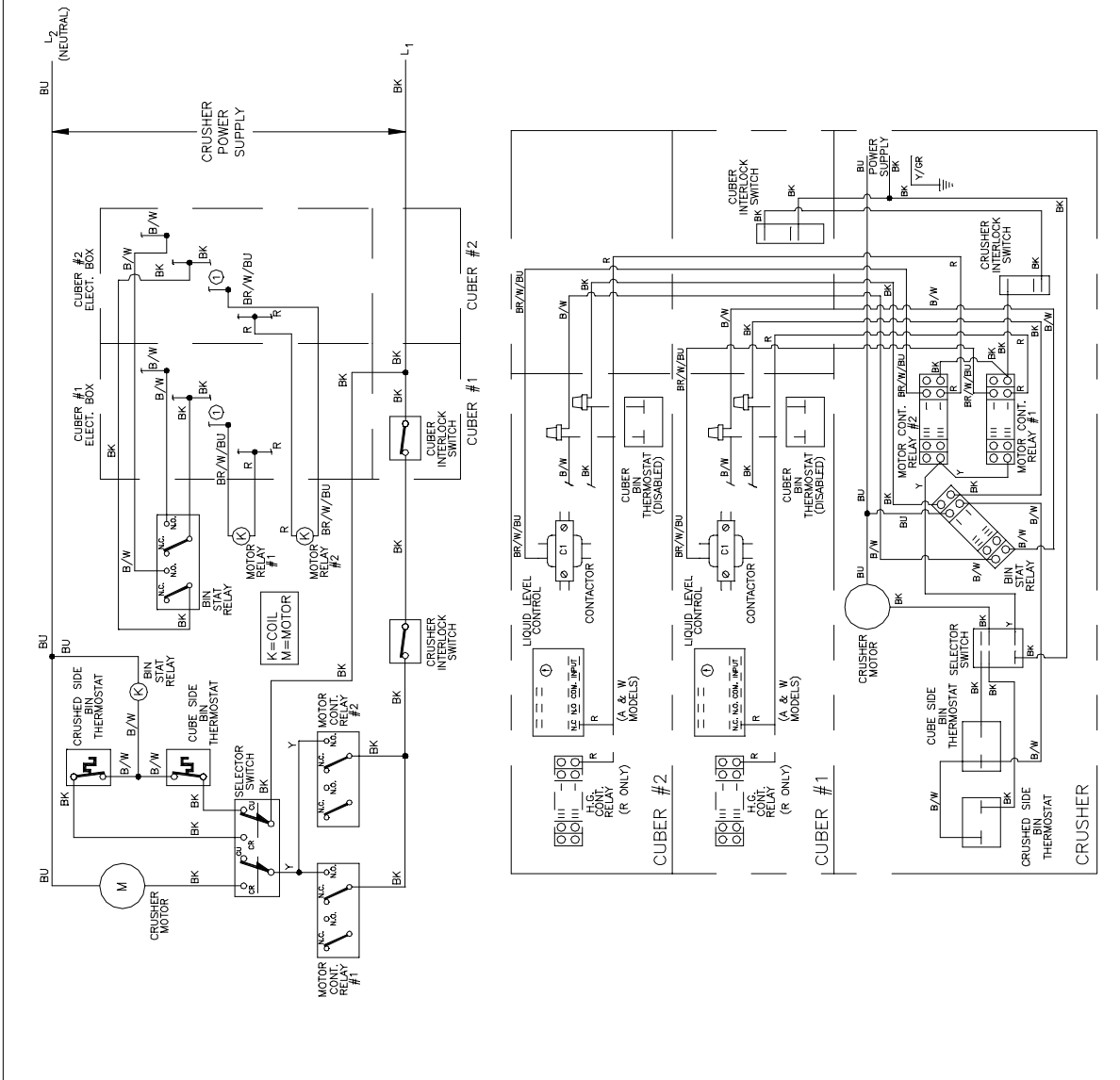

Wiring Diagrams

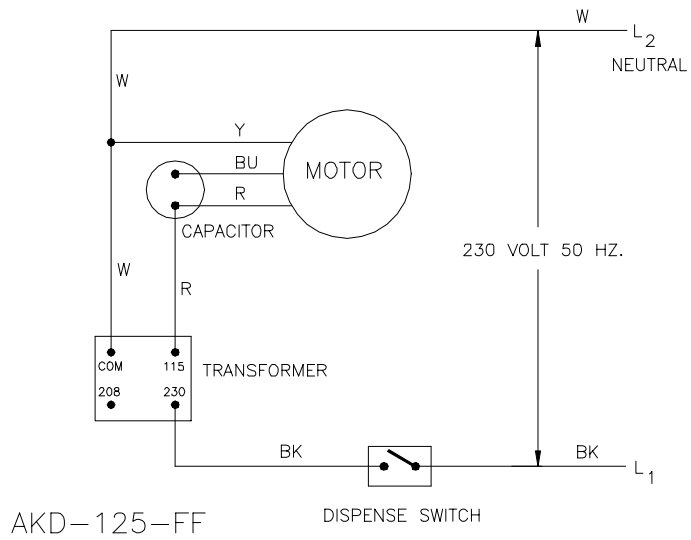
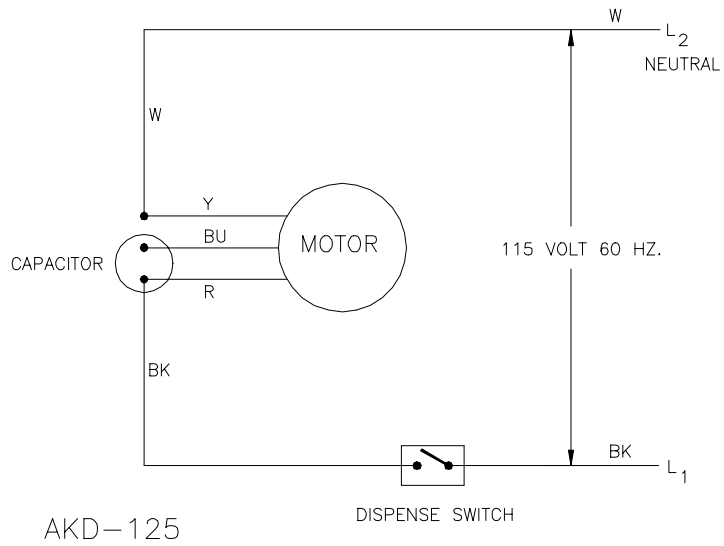

AKD-125 WIRING DIAGRAM
508 1044 01

Parts List-Pictorial

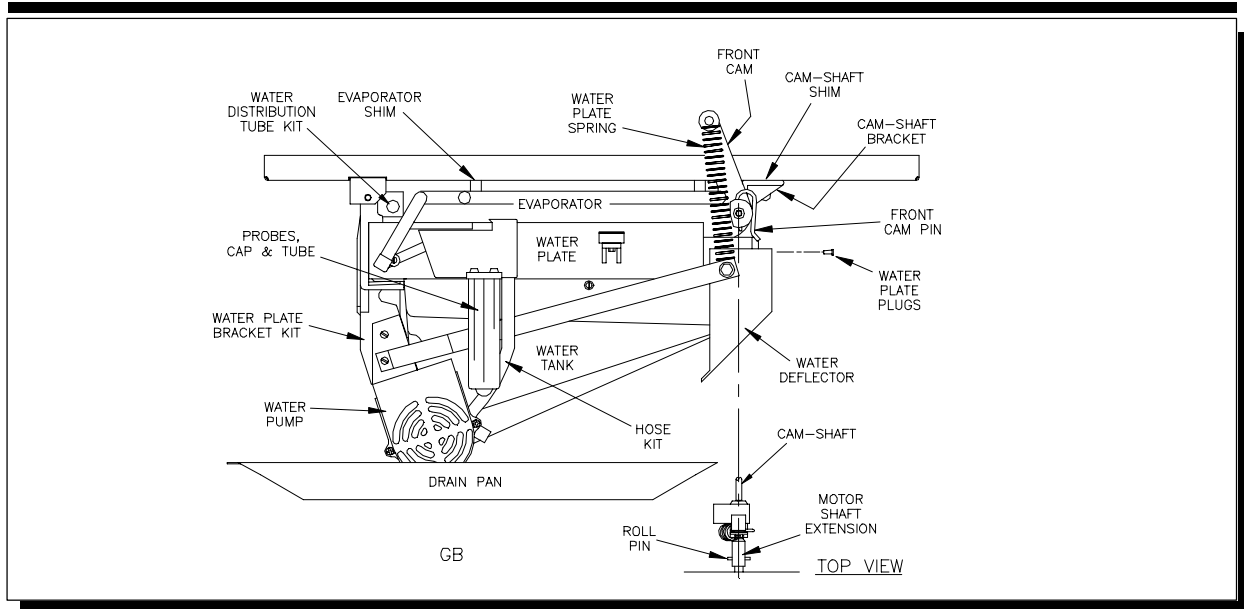

Part Number	Description	Part Number	Description
GAR-00203	Water Tank	GBR-00580	Cam Shaft Shim (2 thin-2 thick)
GBR-00111	Evaporator Shim (10)	GBR-00668	Ice Chute (not shown)
GBR-00113	Evaporator Spacer, "C" or "HK", 4 req'd. (not shown)	GBR-00909	Water Plate Spring (2 req'd.)
GBR-00126	Evaporator Spacer, "K", 4 req'd. (not shown)	GBR-00937	Cam Shaft Bracket (2 req'd.)
GBR-00148	Evaporator (C)	GBR-00942	Cam Shaft
GBR-00153	Evaporator (K)	GBR-00949	Rear Cam (not shown)
GBR-00167	Evaporator (HK)	GBR-00951	Water Plate Spring Boss
GBR-00200	Water Plate (C)	GBR-00959	Roll Pin (10)
GBR-00202	Water Deflector	GBR-00969	Front Cam
Click Here	Water Pump (GB421/431/441/451)	GBR-02087	Hose Kit
Click Here	Water Pump (GB427/437/ 447/457/627/637/647/657)	102 1100 01	Drain Pan Assembly
GBR-00223	Water Plate Plugs (12)	Click Here	WaterPump (GB434/444/454/624/634/ 644/654/1220/1240/1250)
GBR-00245	Water Tank Screen (not shown)	102 1209 01	Motor Shaft Extension
GBR-00270	Water Plate (HK & K)	102 1210 01	Front Cam Pin (5)
GBR-00282-06	Water Plate Bracket Kit (front & rear)	102 1211 01	Ice Deflector (not shown)
GBR-00403	Water Distrib. Tube Kit	102 1216 01	Probes, Cap & Tube

Parts List-Pictorial

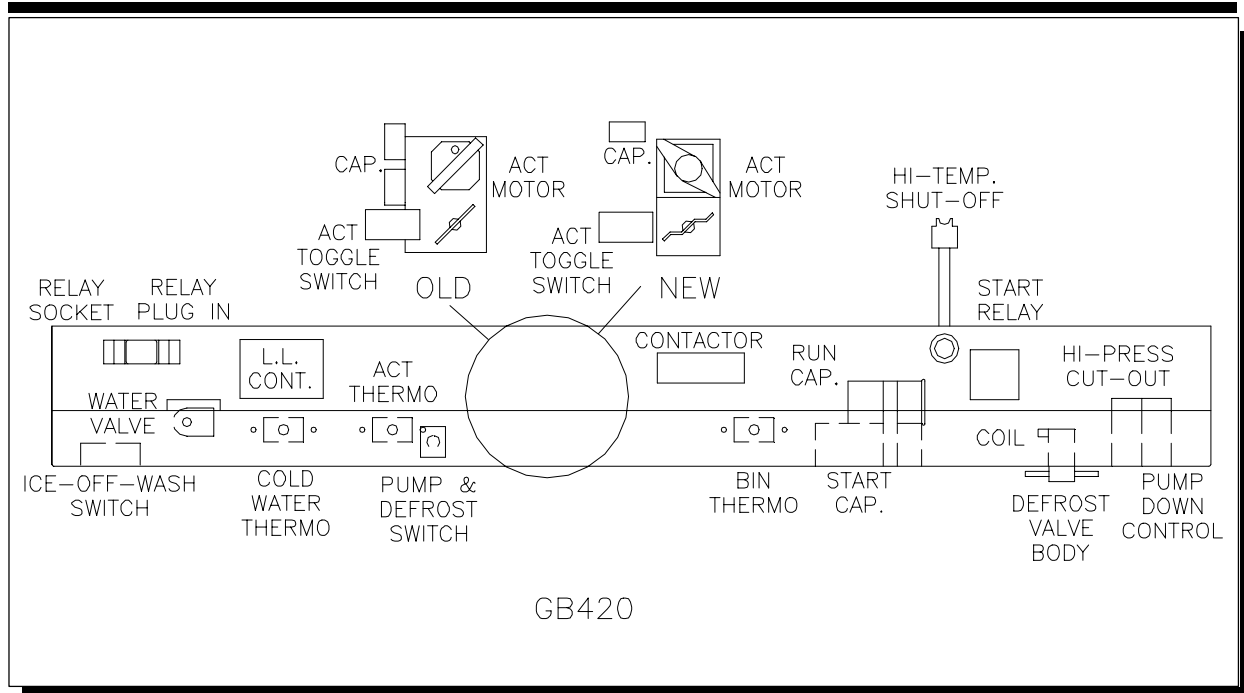

Part Number	Description	Part Number	Description
GBR-00813	Bin Thermo. 120" cap. tube	102 1036 01	Contactor (GB427)
GBR-00814	Actuator Thermostat	102 1037 01	Relay-Plug in (GB421R)
GBR-00826	Capacitor 1.5 Mfd. Old act. motor	102 1044 01	Run Cap. (GB421, RSU5)
GBR-00837	Cold Water Thermostat	102 1048 01	Start Relay (GB421, RSU5)
GBR-00856	Bin Thermo. 66" cap. tube	102 1053 01	ICE-OFF-WASH Switch
GBR-00897	Actuator Toggle Switch	102 1142 01	L.L.Cont. (GB427)
GBR-01375	Water Valve (GB421)	102 1190 01	Hi-Temp. Shutoff, OBS.
GBR-01376-FF	Water Valve (GB427)	102 1194 01	Start Relay (GB427, RSU5)
GBR-02354	High Pressure Cutoff (Auto. reset, R-502)	102 1195 01	Start Cap (GB427, RSU5)
GBR-03153	Actuator Motor <u>Old</u> , OBS.	102 1198 01	O/L Prot. (GB421, RSU5)
GBR-03370	Pump Down Cont.(Remotes)	102 1199 01	O/L Prot. (GB427, RSU5)
GTR-00373-02	Start Cap (GB421, RSU5)	102 1206 01	L.L.Cont. (GB421)
102 1007 01	Relay Socket (Remotes)	102 1217 01	P. & D. Switch
102 1010 01	Defrost Valve Body	102 1292 01	Act. Motor <u>New</u> (GB421)
102 1011 01	Coil (GB421)	102 1292 02	Act. Motor <u>New</u> (GB427)
102 1012 01	Coil (GB427)	102 1241 01	Cap. 4 Mfd. (GB421) <u>New</u>
102 1035 01	Contactor (GB421)	102 1241 02	Cap. 1 Mfd. (GB427) <u>New</u>

Parts List-Pictorial

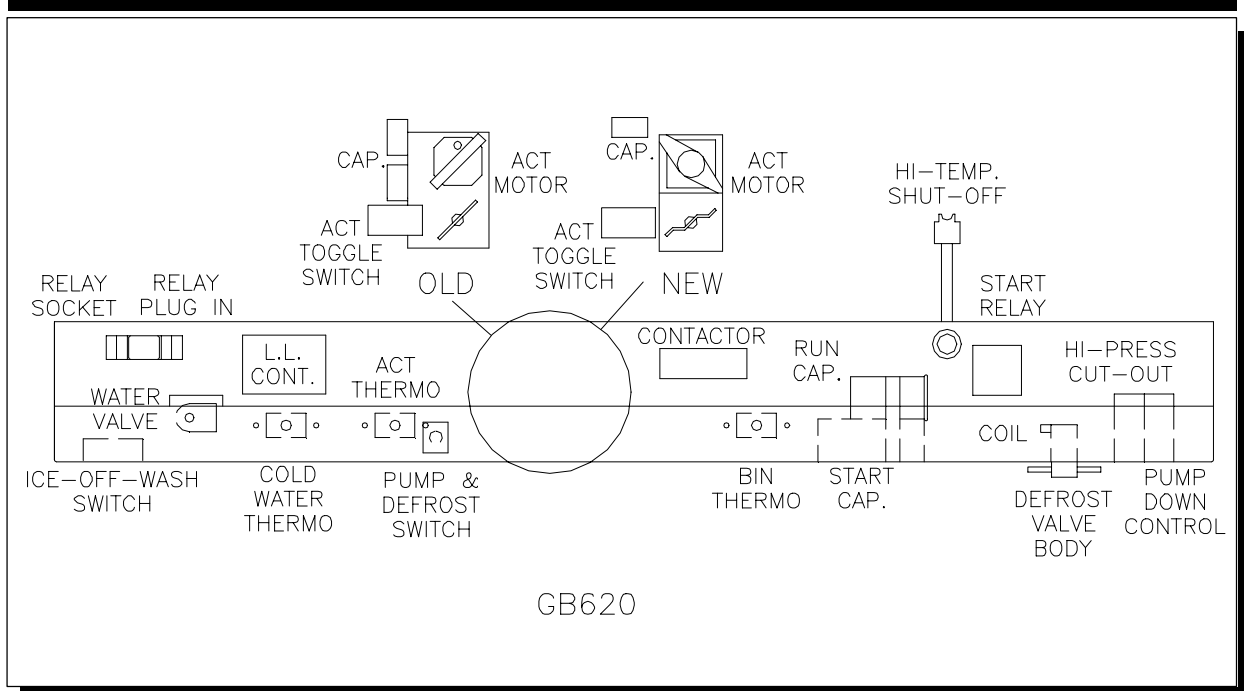

Part Number	Description	Part Number	Description
GBR-00813	Bin Thermo. 120" cap. tube	102 1036 01	Contactor (GB624/627)
GBR-00814	Actuator Thermostat	102 1038 01	Relay-Plug in (GB624R)
GBR-00826	Capacitor 1.5 Mfd. Old act. motor	102 1053 01	ICE-OFF-WASH Switch
GBR-00837	Cold Water Thermostat	102 1142 01	L.L.Cont. (GB624/627)
GBR-00856	Bin Thermo. 66" cap. tube	102 1190 01	Hi-Temp. Shutoff, OBS.
GBR-00897	Actuator Toggle Switch	102 1195 02	Start Cap. (GB627 C. RSL5)
GBR-01376-FF	Water Valve (GB624/627)	102 1196 01	Start Cap. (GB624, RSL5)
GBR-01385-01	Start Relay (GB624/627, RSL5)	102 1197 01	Run Cap. (GB624)
GBR-02354	High Pressure Cutoff (Auto. reset, R-502)	102 1197 02	Run Cap. (GB627, RSL5)
GBR-03153	Actuator Motor <u>Old</u> , OBS.	102 1200 01	O/L Prot. (GB624, RSL5)
GBR-03370	Pump Down Cont.(Remotes)	102 1217 01	P. & D. Switch
102 1007 01	Relay Socket (Remotes)	102 1223 01	Capacitor, 2.0 Mfd, GB624 OLD Actuator Motor only
102 1010 01	Defrost Valve Body	102 1292 02	Act. Motor <u>New</u>
102 1012 01	Coil (GB624/627)	102 1241 02	Cap. 1 Mfd. <u>New Act. Motor</u>

Parts List-Pictorial

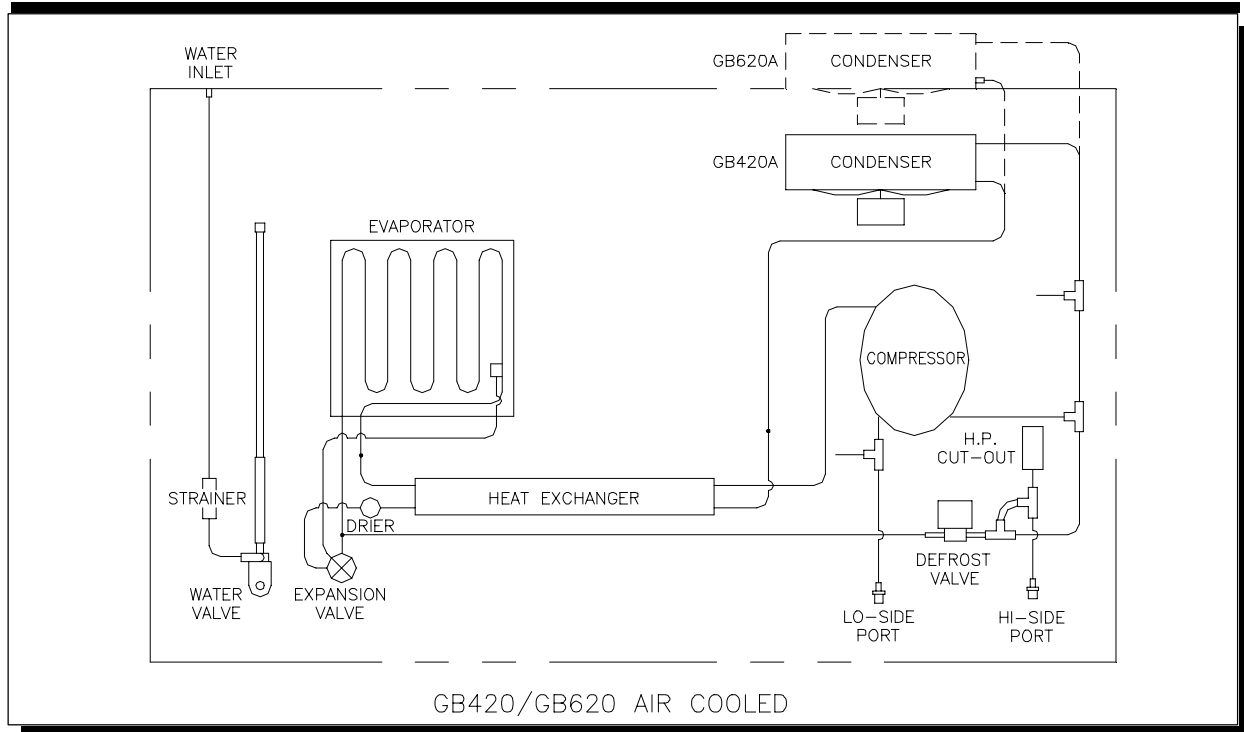

Part Number	Description	Part Number	Description
GBR-00148	Evaporator (C)	GBR-02750	Drier
GBR-00153	Evaporator (K)	GBR-03347	Air Cooled Condenser (GB624/627)
GBR-00167	Evaporator (HK)	102 1010 01	Defrost Valve Body
GBR-01353	Air Cooled Condenser (GB421/427)	102 1011 01	Defrost Valve Coil (GB421)
GBR-01360	Fan Blade	102 1012 01	Defrost Valve Coil (GB427/624/627)
GBR-01362	Fan Support (GB421)	102 1212 01	Fan Motor (GB427/624/627)
GBR-01363	Fan Shroud (GB421/427)	102 1213 01	Fan Support (GB427)
GBR-01364	Fan Motor (GB421)	102 1214 01	Fan Support (GB624/627)
GBR-01375	Water Valve (GB421)	102 1215 01	Fan Shroud (GB624/627)
GBR-01376-FF	Water Valve (GB427/624/627)	102 1242 14	Compressor Replacement Kit (GB624)
GBR-01379	Strainer	102 1242 15	Compressor Replacement Kit (GB421)
GBR-02354	High Pressure Cutoff, Auto. reset, R-502	102 1242 16	Compressor Replacement Kit (GB627)
GBR-02359	Expansion Valve	102 1242 17	Compressor Replacement Kit (GB427)

Parts List-Pictorial

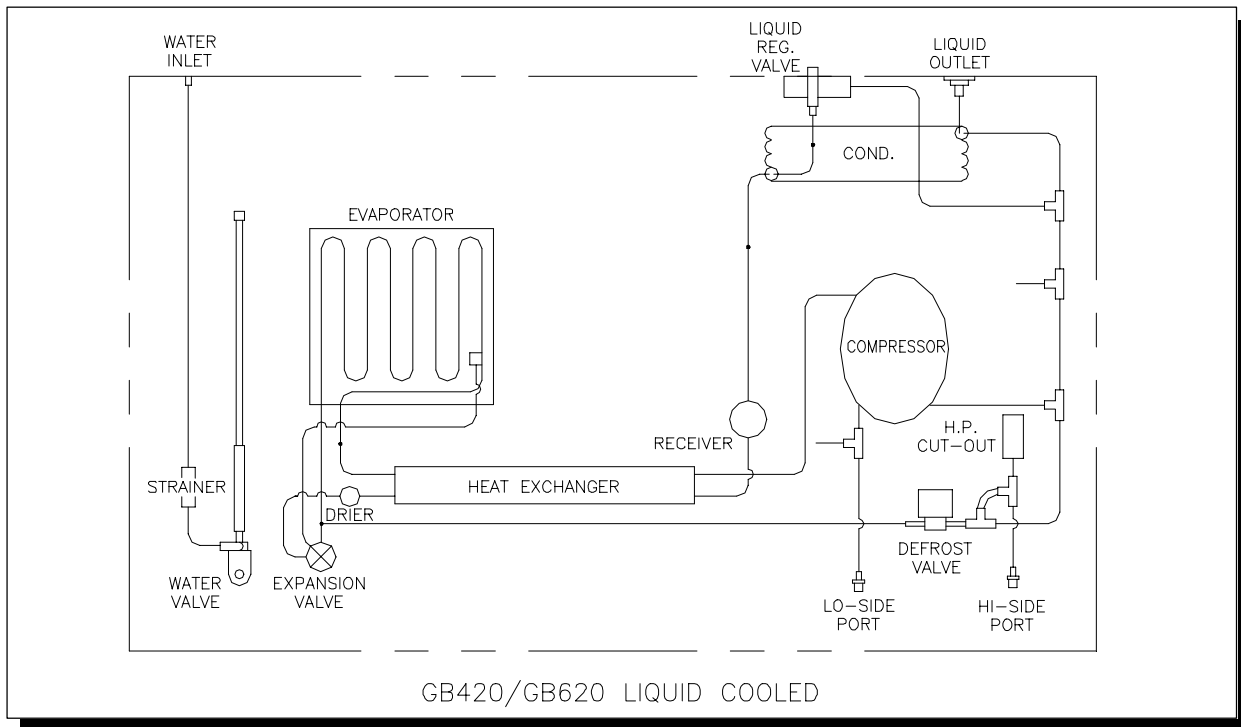

Part Number	Description	Part Number	Description
GAR-00701-D	Liquid Regulator Valve	GTR-00705	Liquid Cooled Condenser
GBR-00148	Evaporator (C)	102 1010 01	Defrost Valve Body
GBR-00153	Evaporator (K)	102 1011 01	Defrost Valve Coil (GB421)
GBR-00167	Evaporator (HK)	102 1012 01	Defrost Valve Coil (GB427/624/627)
GBR-01375	Water Valve (GB421)	102 1066 01	Receiver
GBR-01376-FF	Water Valve (GB427/624/627)	102 1242 14	Compressor Replacement Kit (GB624)
GBR-01379	Strainer	102 1242 15	Compressor Replacement Kit (GB421)
GBR-02354	High Pressure Cutoff, Auto. reset, R-502	102 1242 16	Compressor Replacement Kit (GB627)
GBR-02359	Expansion Valve	102 1242 17	Compressor Replacement Kit (GB427)
GBR-02750	Drier		

Parts List-Pictorial

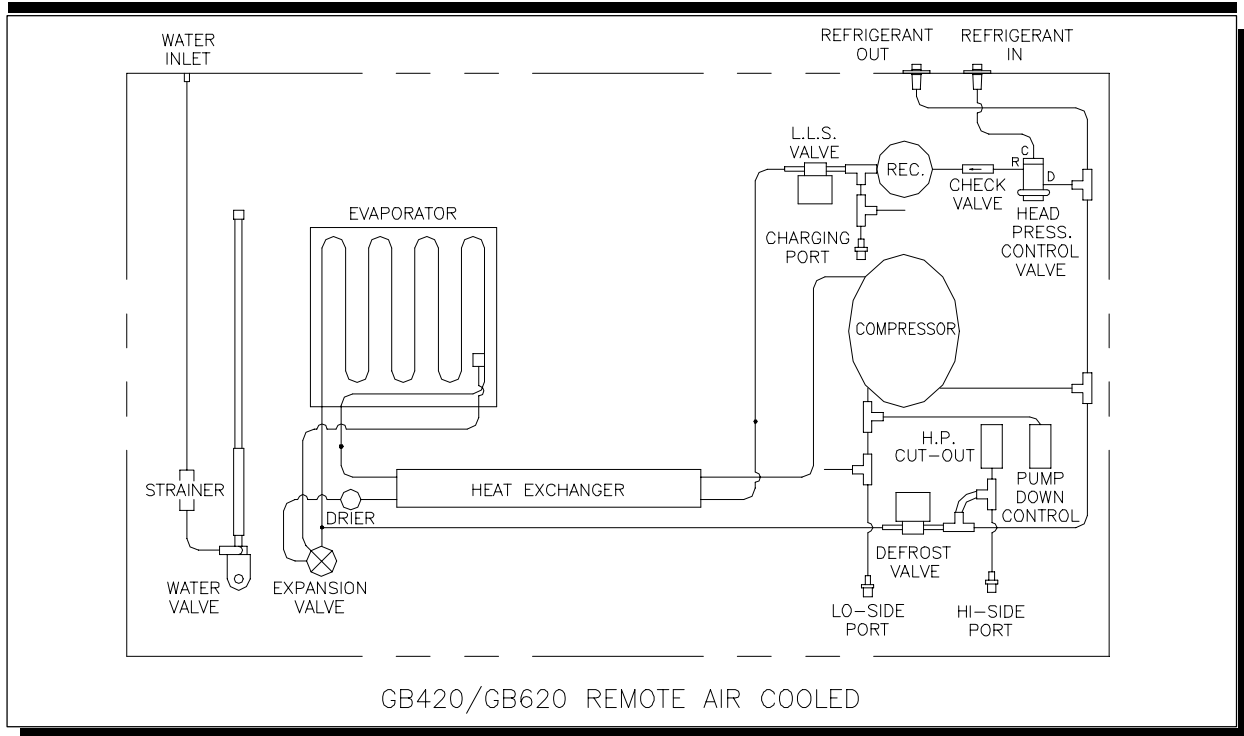

Part Number	Description	Part Number	Description
GBR-00148	Evaporator (C)	GBR-02359	Expansion Valve
GBR-00153	Evaporator (K)	GBR-02750	Drier
GBR-00167	Evaporator (HK)	GBR-03370	Pump Down Control
GBR-01375	Water Valve (GB421)	102 1010 01	Defrost & Liquid Line Solenoid Valve Body
GBR-01376-FF	Water Valve (GB427/624/627)	102 1011 01	Defrost & Liquid Line Solenoid Valve Coil (GB421)
GBR-01379	Strainer	102 1012 01	Defrost & Liquid Line Solenoid Valve Coil (GB427/624/627)
GBR-01889	Refrigerant Inlet Fitting 3/8"	102 1023 01	Receiver
GBR-01890	Refrigerant Discharge Fitting 1/2"	102 1242 14	Compressor Replacement Kit (GB624)
GBR-02290	Check Valve	102 1242 15	Compressor Replacement Kit (GB421)
GBR-02351	Head Pressure Control Valve	102 1242 16	Compressor Replacement Kit (GB627)
GBR-02354	High Pressure Cutoff, Auto. reset, R-502	102 1242 17	Compressor Replacement Kit (GB427)

Parts List-Pictorial

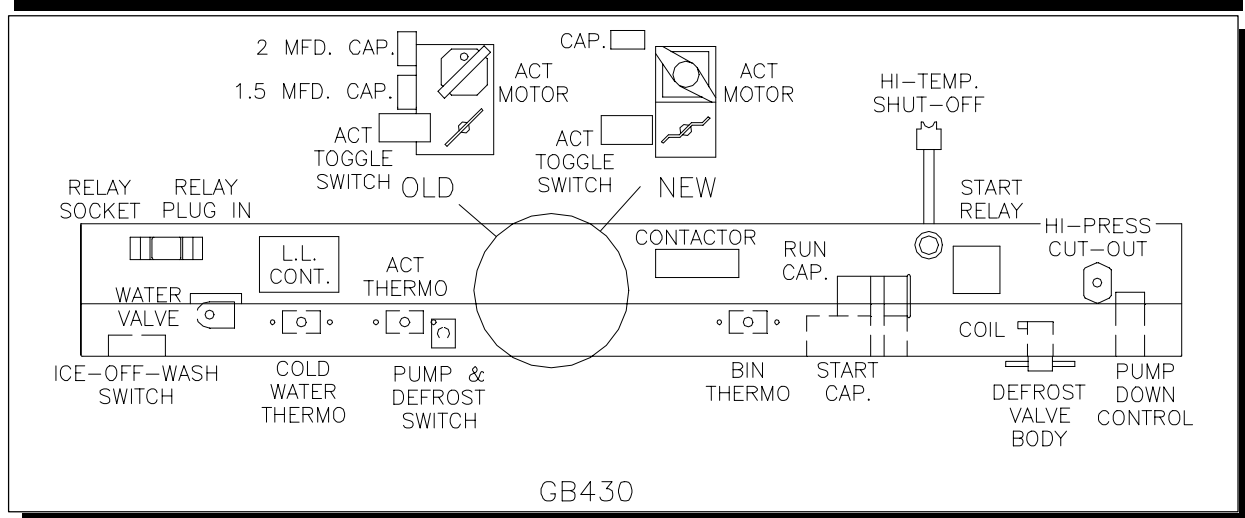

Part Number	Description	Part Number	Description
GBR-00813	Bin Thermo. 120" cap. tube	102 1047 02	Start relay (GB434)
GBR-00814	Actuator Thermostat	102 1047 03	Start relay (GB437)
GBR-00826	Capacitor 1.5 Mfd. Old act. motor	102 1047 04	Start relay (GB431)
GBR-00837	Cold Water Thermostat	102 1053 01	ICE-OFF-WASH Switch
GBR-00856	Bin Thermo. 66" cap. tube	102 1055 01	High Pressure Cutoff, Manual reset, R-502/404a
GBR-00897	Actuator Toggle Switch	102 1142 01	L.L.Cont. (GB434/437)
GBR-01375	Water Valve (GB431)	102 1190 01	Hi-Temp. Shutoff, OBS.
GBR-01376-FF	Water Valve (GB434/437)	102 1195 03	Start Cap (GB431)
GBR-03153	Actuator Motor <u>Old</u> , OBS.	102 1195 06	Start Cap (GB434)
GBR-03370	Pump Down Cont. (Remotes)	102 1196 01	Start Cap (GB437)
102 1007 01	Relay Socket (Remotes)	102 1197 04	Run Cap. (GB437)
102 1008 01	Defrost Valve Body (R)	102 1206 01	L.L.Cont. (GB431)
102 1010 01	Defrost Valve Body (A & W)	102 1217 01	P. & D. Switch
102 1011 01	Coil (GB431)	102 1223 01	Capacitor 2.0 Mfd., (GB434) <u>Old</u> act. motor
102 1012 01	Coil (GB434/437)	102 1292 01	Act. Motor <u>New</u> (GB431)
102 1035 01	Contactor (GB431)	102 1292 02	Act. Motor <u>New</u> (GB434/437)
102 1036 01	Contactor (GB434/437)	102 1241 01	Cap. 4 Mfd. (GB431) <u>New</u>
102 1037 01	Relay-Plug in (GB431R)	102 1241 02	Cap. 1 Mfd. (GB434/437) <u>New</u>
102 1044 01	Run Cap. (GB431/434)		

Parts List-Pictorial

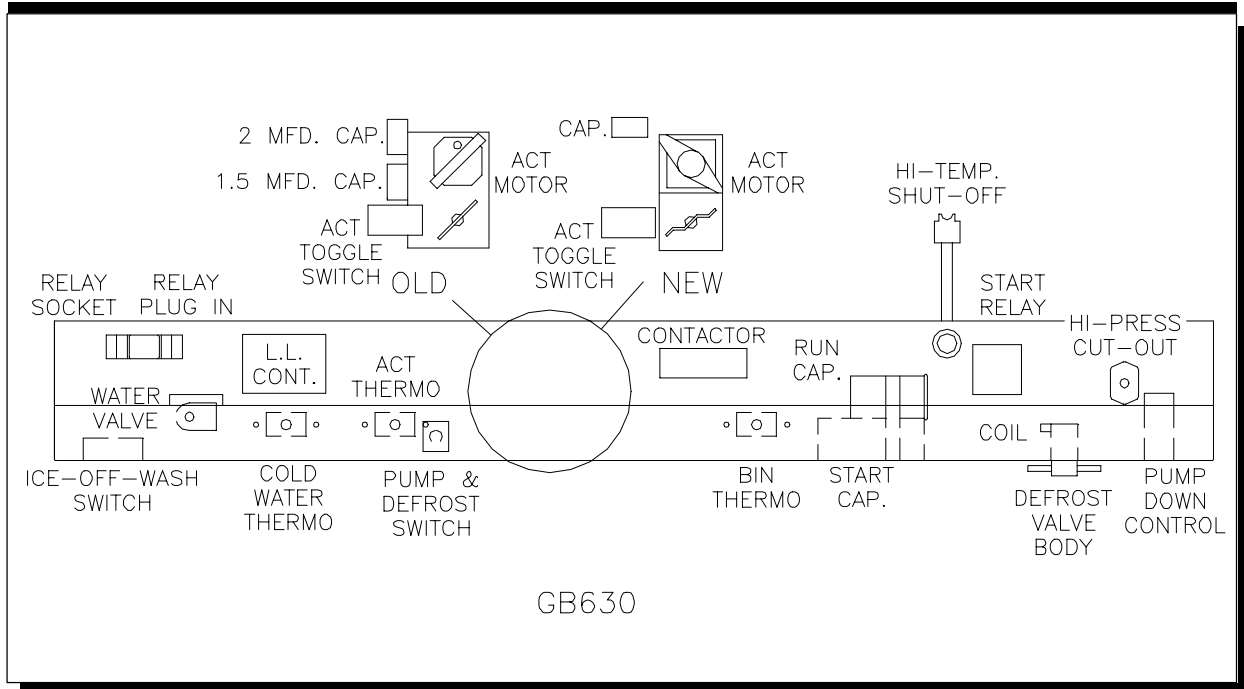

Part Number	Description	Part Number	Description
GBR-00813	Bin Thermo. 120" cap. tube	102 1036 01	Contactor (GB634/637)
GBR-00814	Actuator Thermostat	102 1038 01	Relay-Plug in (GB634R)
GBR-00826	Capacitor 1.5 Mfd. Old act. motor	102 1047 02	Start relay (GB634)
GBR-00837	Cold Water Thermostat	102 1047 03	Start relay (GB637)
GBR-00856	Bin Thermo. 66" cap. tube	102 1053 01	ICE-OFF-WASH Switch
GBR-00897	Actuator Toggle Switch	102 1055 01	High Pressure Cutoff, Manual reset, R-502/404a
GBR-01376-FF	Water Valve (GB634/637)	102 1142 01	L.L.Cont. (GB634/637)
GBR-01385-03	Run Cap. (GB634/637)	102 1190 01	Hi-Temp. Shutoff, OBS.
GBR-03153	Actuator Motor <u>Old</u> , OBS.	102 1195 04	Start Cap (GB634/637)
GBR-03370	Pump Down Cont.-Remotes	102 1217 01	P. & D. Switch
102 1007 01	Relay Socket (Remotes)	102 1223 01	Capacitor 2.0 Mfd. (GB634) <u>Old</u> act. motor
102 1010 01	Defrost Valve Body	102 1292 02	Act. Motor <u>New</u>
102 1012 01	Coil (GB634/637)	102 1241 02	Cap. 1 Mfd. <u>New</u>

Parts List-Pictorial

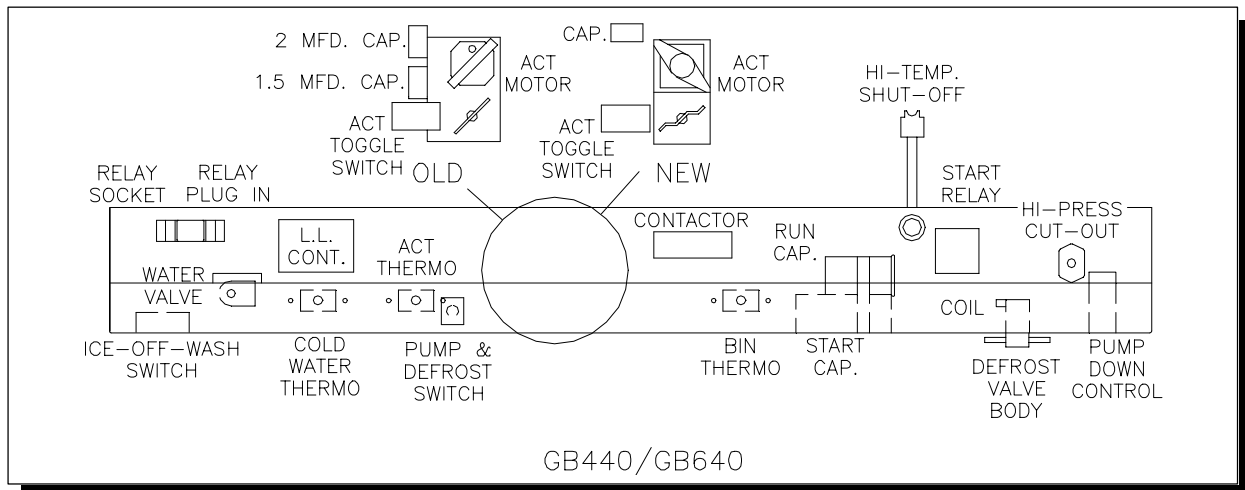

Part Number	Description	Part Number	Description
GBR-00813	Bin Thermo. 120" cap. tube	102 1047 03	Start relay (GB647)
GBR-00814	Actuator Thermostat	102 1047 04	Start relay (GB441)
GBR-00826	Capacitor 1.5 Mfd. Old act. motor	102 1047 05	Start relay (GB644)
GBR-00837	Cold Water Thermostat	102 1047 07	Start relay (GB447)
GBR-00856	Bin Thermo. 66" cap. tube	102 1047 08	Start relay (GB444)
GBR-00897	Actuator Toggle Switch	102 1053 01	ICE-OFF-WASH Switch
GBR-01375	Water Valve (GB441)	102 1055 01	High Pressure Cutoff, Manual reset, R-502/404a
GBR-01376-FF	Water Valve GB444/447/640	102 1142 01	L.L.Cont. (GB444/447/640)
GBR-01385-03	Run Cap. (GB441/647)	102 1190 01	Hi-Temp. Shutoff, OBS.
GBR-02353-02	Start Cap (GB441)	102 1195 03	Start Cap. (GB447)
GBR-03153	Actuator Motor <u>Old</u> , OBS.	102 1195 04	Start Cap. (GB647)
GBR-03370	Pump Down Cont. (Remotes)	102 1195 05	Start Cap. (GB444/644)
102 1007 01	Relay Socket (Remotes)	102 1197 01	Run Cap. (GB444/447/644)
102 1008 01	Defr. Valve Body (GB441R)	102 1206 01	Liquid Level Cont. (GB441)
102 1010 01	Defrost Valve Body (GB440A/440W/640)	102 1217 01	P. & D. Switch
102 1011 01	Coil (GB441)	102 1223 01	Capacitor 2.0 Mfd.,(GB444/644) <u>Old</u> act. motor
102 1012 01	Coil (GB444/447/640)	102 1292 01	Act. Motor <u>New</u> (GB441)
102 1035 01	Contactor (GB441)	102 1292 02	Act. Motor <u>New</u> (GB444/447/640)
102 1036 01	Contactor (GB444/447/640)	102 1241 01	Cap. 4 Mfd. (GB441) <u>New</u>
102 1037 01	Relay-Plug in (GB441R)	102 1241 02	Cap. 1 Mfd. (GB444/447/640) <u>New</u>
102 1038 01	Relay-Plug in (GB644R/447R)		

Parts List-Pictorial

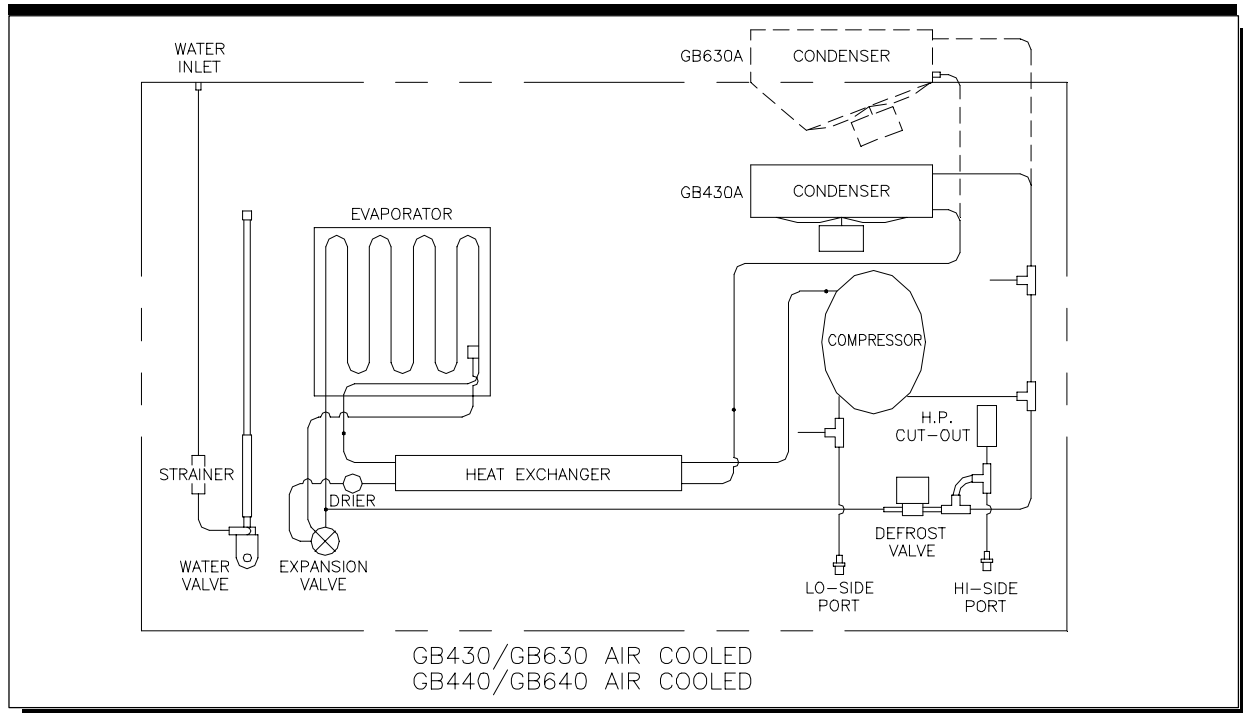

Part Number	Description	Part Number	Description
GBR-00148	Evaporator (C)	102 1011 01	Defr. Valve Coil (GB431/441)
GBR-00153	Evaporator (K)	102 1012 01	Defrost Valve Coil (GB434/437/444/447/630/640)
GBR-00167	Evaporator (HK)	102 1018 02	Air Cooled Condenser (GB630/640)
GBR-01353	Air Cooled Condenser (GB430/440)	102 1055 01	High Pressure Cutoff, Manual reset, R-502/404a
GBR-01360	Fan Blade	102 1212 01	Fan Motor GB434/437/444/447/630/640
GBR-01362	Fan Support (GB431/441)	102 1213 01	Fan Support GB434/437/444/447
GBR-01363	Fan Shroud (GB430/440)	102 1214 01	Fan Support (GB630/640)
GBR-01364	Fan Motor (GB431/441)	102 1215 02	Fan Shroud (GB630/640)
GBR-01375	Water Valve (GB431/441)	102 1242 14	Comp. Repl. Kit (GB634/644)
GBR-01376-FF	Water Valve(GB434/437/444/447/630/640)	102 1242 15	Comp. Repl. Kit (GB431/441)
GBR-01379	Strainer	102 1242 16	Comp. Repl. Kit (GB637/647)
GBR-02359	Expansion Valve	102 1242 17	Comp. Repl. Kit (GB437/447)
GBR-02750	Drier	102 1242 18	Comp. Repl. Kit (GB434/444)
102 1010 01	Defrost Valve Body		

Parts List-Pictorial

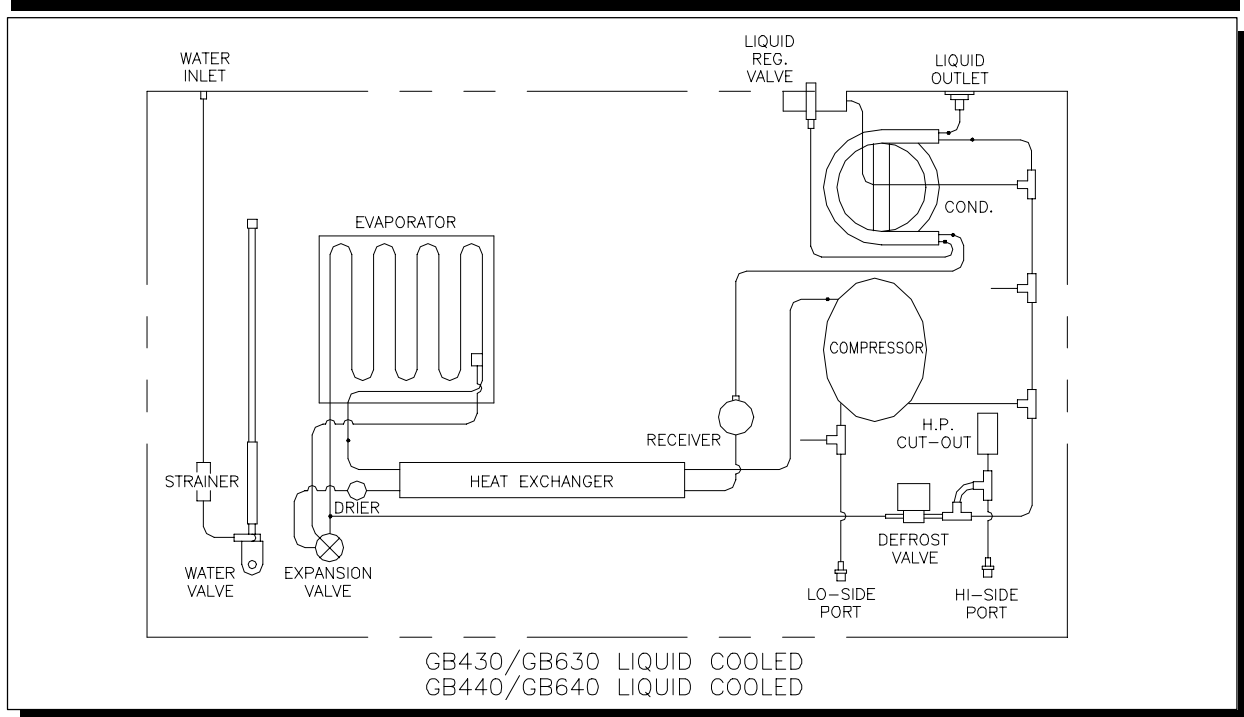

Part Number	Description	Part Number	Description
GAR-00701-D	Liquid Regulator Valve	102 1012 01	Defrost Valve Coil (GB434/437/444/447/630/640)
GBR-00148	Evaporator (C)	102 1020 01	Liquid Cooled Condenser (GB430/440)
GBR-00153	Evaporator (K)	102 1021 01	Liquid Cooled Condenser (GB630/640)
GBR-00167	Evaporator (HK)	102 1055 01	High Pressure Cutoff, Manual reset, R-502/404a
GBR-01375	Water Valve (GB431/441)	102 1066 01	Receiver
GBR-01376-FF	Water Valve (GB434/437/444/447/630/640)	102 1242 14	Comp. Repl. Kit (GB634/644)
GBR-01379	Strainer	102 1242 15	Comp. Repl. Kit (GB431/441)
GBR-02359	Expansion Valve	102 1242 16	Comp. Repl. Kit (GB637/647)
GBR-02750	Drier	102 1242 17	Comp. Repl. Kit (GB437/447)
102 1010 01	Defrost Valve Body	102 1242 18	Comp. Repl. Kit (GB434/444)
102 1011 01	Defrost Valve Coil (GB431/441)		

Parts List-Pictorial

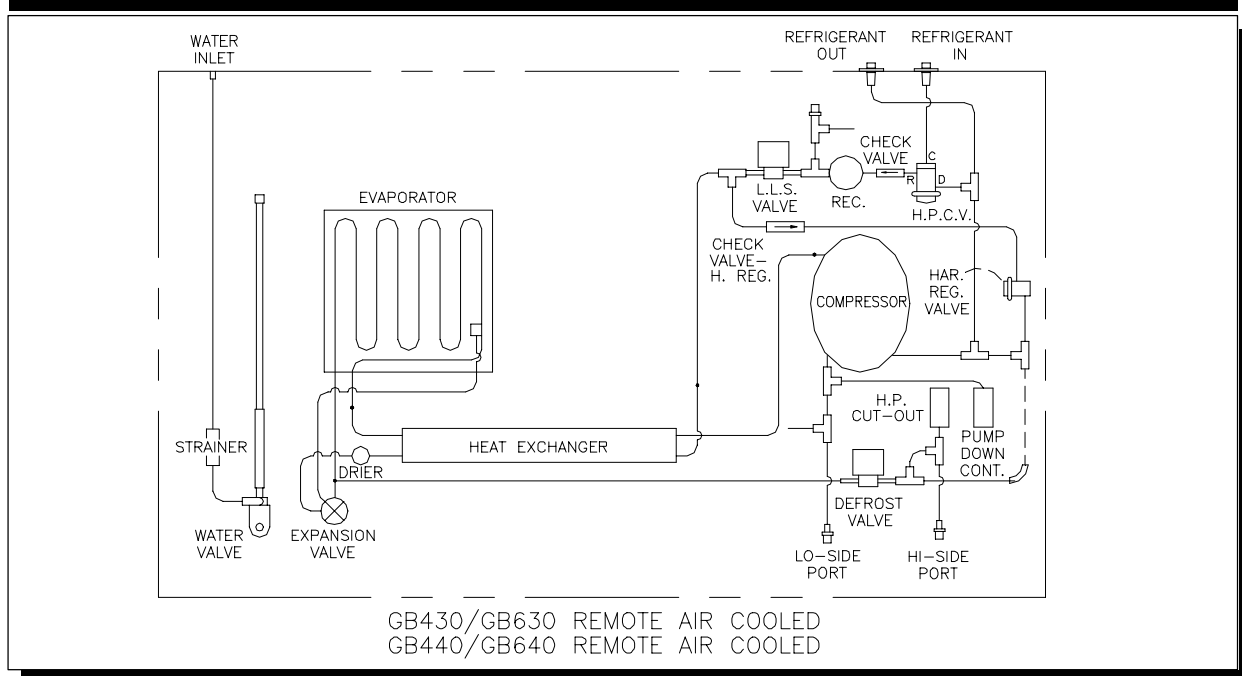

Part Number	Description	Part Number	Description
GBR-00148	Evaporator (C)	102 1010 01	Defrost (GB630/640) & L.L. Sol. Valve Body (GB430/440/630/640)
GBR-00153	Evaporator (K)	102 1011 01	Defr. & L.L. Sol. Valve Coil (GB431/441)
GBR-00167	Evaporator (HK)	102 1012 01	Defr. & L. L. Sol. Valve Coil (GB434/437/444/447/630/640)
GBR-01375	Water Valve (GB431/441)	102 1023 01	Receiver
GBR-01376-FF	Water Valve (GB434/437/444/447/630/640)	102 1055 01	High Pressure Cutoff, Manual reset, R-502/404a
GBR-01379	Strainer	102 1071 01	Drier (GB440/640)
GBR-01889	Refrigerant Inlet Fitting, 3/8"	102 1166 02	Check Valve, Harvest Regulator
GBR-01890	Refrigerant Discharge Fitting, 1/2"	102 1220 01	Harvest Regulator Valve
GBR-02290	Check Valve	102 1242 14	Comp. Repl. Kit (GB634/644)
GBR-02351	Head Press. Control Valve	102 1242 15	Comp. Repl. Kit (GB431/441)
GBR-02359	Expansion Valve	102 1242 16	Comp. Repl. Kit (GB637/647)
GBR-02750	Drier (GB430/630)	102 1242 17	Comp. Repl. Kit (GB437/447)
GBR-03370	Pump Down Control	102 1242 18	Comp. Repl. Kit (GB434/444)
102 1008 01	Defrost Valve Body (GB430/440)		

Parts List-Pictorial

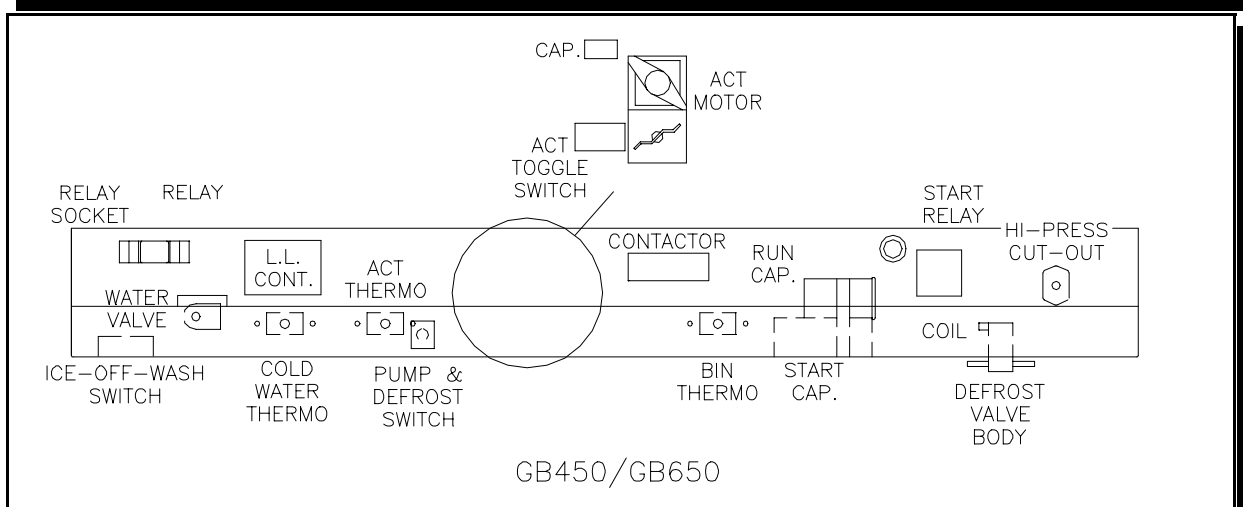

Part Number	Description	Part Number	Description
GBR-00813	Bin Thermo. 120" cap. tube	102 1047 12	Start relay (GB657)
GBR-00814	Actuator Thermostat	102 1047 13	Start relay (GB654)
GBR-00837	Cold Water Thermostat	102 1053 01	ICE-OFF-WASH Switch
GBR-00856	Bin Thermo. 66" cap. tube	102 1055 01	High Pressure Cutoff, Manual reset, R-404a
GBR-00897	Actuator Toggle Switch	102 1142 01	L.L.Cont. (GB454/457/650)
GBR-01375	Water Valve (GB451)	102 1195 02	Start Cap. (GB454/457)
GBR-01376-FF	Water Valve (GB454/457/650)	102 1195 08	Start Cap. (GB451)
102 1007 01	Relay Socket (Remotes)	102 1195 09	Start Cap. (GB654)
102 1010 01	Defrost Valve Body (GB450A/450W/650)	102 1195 10	Start Cap. (GB657)
102 1011 01	Coil (GB451)	102 1197 02	Run Cap. (GB654/657)
102 1012 01	Coil (GB454/457/650)	102 1197 04	Run Cap. (GB451)
102 1035 01	Contactor (GB451)	102 1206 01	Liquid Level Cont. (GB451)
102 1036 01	Contactor (GB454/457/650)	102 1217 01	P. & D. Switch
102 1038 01	Relay-Plug in (GB650R)	102 1292 01	Act. Motor <u>New</u> (GB451)
102 1044 01	Run Cap. (GB454/457)	102 1292 02	Act. Motor <u>New</u> (GB454/457/650)
102 1047 06	Start relay (GB454)	102 1241 01	Cap. 4 Mfd. (GB451) <u>New</u>
102 1047 09	Start relay (GB451)	102 1241 02	Cap. 1 Mfd. (GB454/457/650) <u>New</u>
102 1047 11	Start relay (GB457)		

Parts List-Pictorial

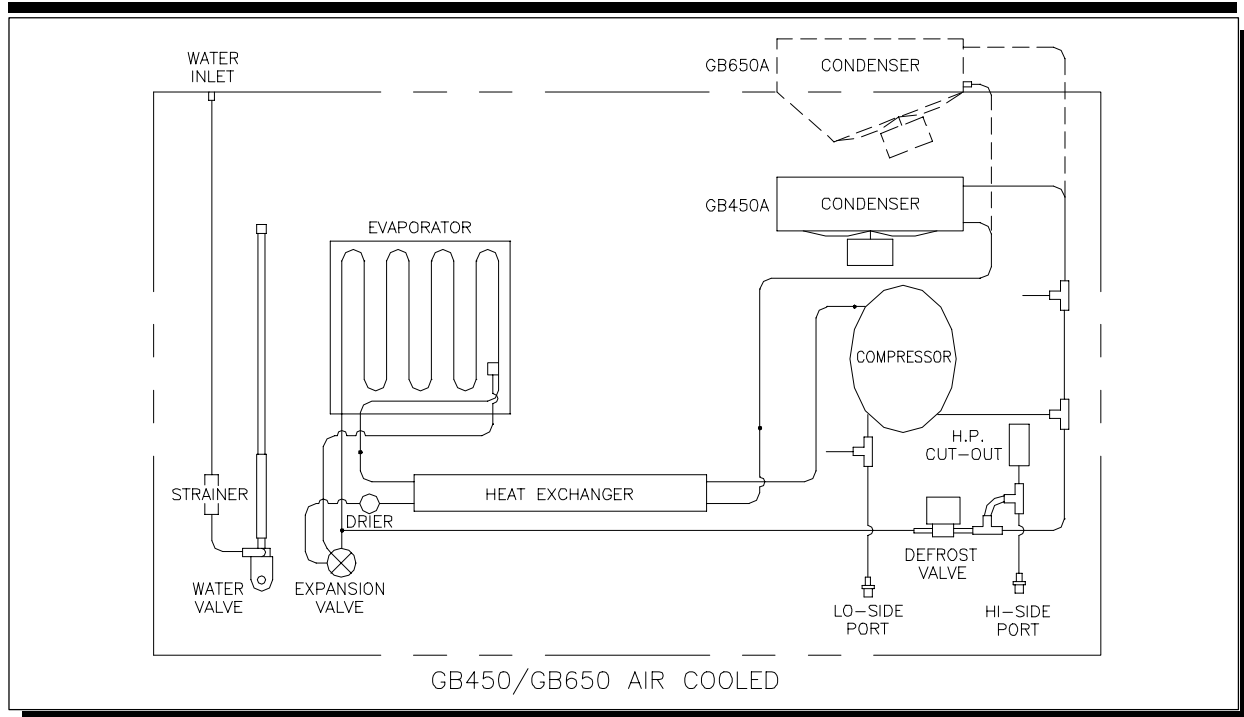

Part Number	Description	Part Number	Description
GBR-00148	Evaporator (C)	102 1016 03	Fan Blade (GB451A/454A)
GBR-00153	Evaporator (K)	102 1018 02	Air Cooled Condenser (GB650A)
GBR-00167	Evaporator (HK)	102 1055 01	High Pressure Cutoff, Manual reset, R-404a
GBR-01353	Air Cooled Condenser (GB450A)	102 1188 02	Expansion Valve (GB450)
GBR-01375	Water Valve (GB451)	102 1191 26	Compressor (GB654)
GBR-01376-FF	Water Valve (GB454/457/650)	102 1191 27	Compressor (GB657)
GBR-01379	Strainer	102 1191 28	Compressor (GB451)
GBR-02359	Expansion Valve (GB650)	102 1191 29	Compressor (GB457)
GBR-02750	Drier	102 1191 31	Compressor (GB454)
102 1010 01	Defrost Valve Body	102 1198 05	Comp. O/L (GB457)
102 1011 01	Defr. Valve Coil (GB451)	102 1198 06	Comp. O/L (GB451)
102 1012 01	Defrost Valve Coil (GB454/457/650)	102 1198 07	Comp. O/L (GB454)
102 1014 01	Fan Motor (GB451A)	102 1214 02	Fan Support (GB450A)
102 1014 02	Fan Motor (GB457A/657A)	102 1214 04	Fan Support (GB650A)
102 1015 01	Fan Motor (GB454A/654A)	102 1215 02	Fan Shroud (GB650A)
102 1016 02	Fan Blade (GB457A/650A)	102 1215 03	Fan Shroud (GB450A)

Parts List-Pictorial

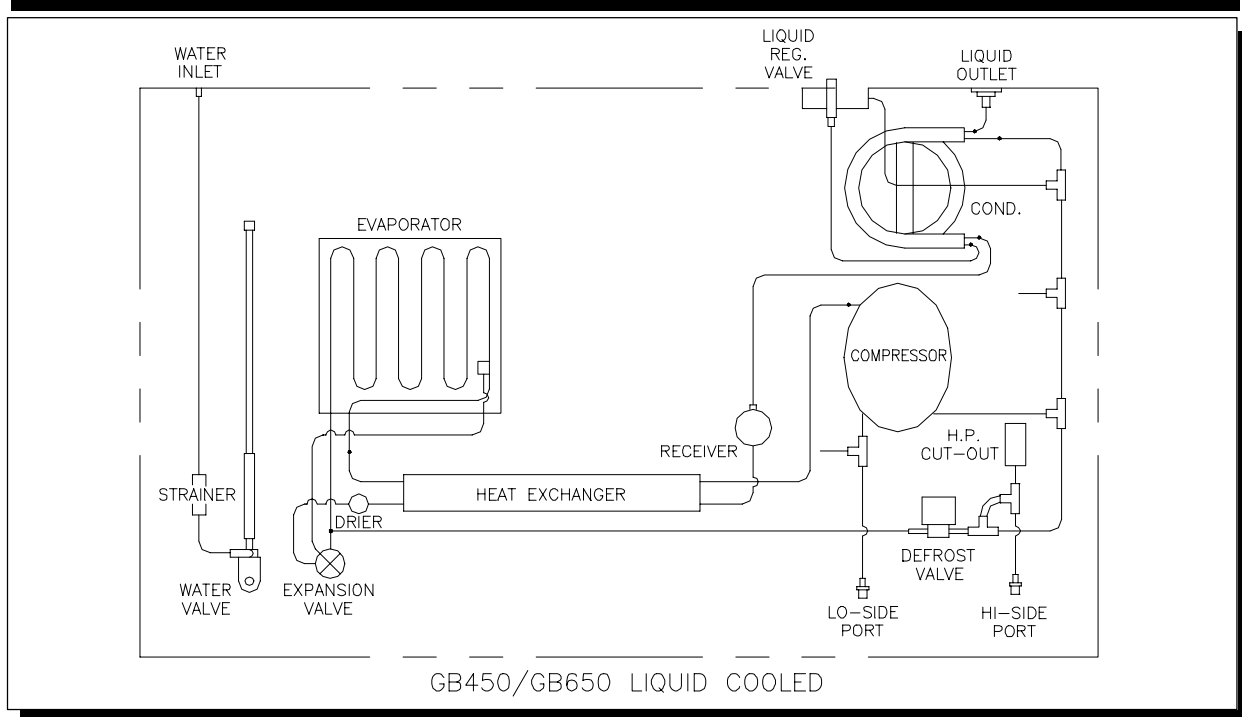

Part Number	Description	Part Number	Description
GAR-00701-D	Liquid Regulator Valve	102 1020 05	Marine Liquid Cooled Condenser (MGB450W)
GBR-00148	Evaporator (C)	102 1021 01	Liquid Cooled Condenser (GB650W)
GBR-00153	Evaporator (K)	102 1055 01	High Pressure Cutoff, Manual reset, R-404a
GBR-00167	Evaporator (HK)	102 1066 01	Receiver
GBR-01375	Water Valve (GB451)	102 1188 02	Expansion Valve (GB450)
GBR-01376-FF	Water Valve (GB454/457/650)	102 1191 26	Compressor (GB654)
GBR-01379	Strainer	102 1191 27	Compressor (GB657)
GBR-02359	Expansion Valve (GB650)	102 1191 28	Compressor (GB451)
GBR-02750	Drier	102 1191 29	Compressor (GB457)
102 1010 01	Defrost Valve Body	102 1191 31	Compressor (GB454)
102 1011 01	Defrost Valve Coil (GB451)	102 1198 05	Comp. O/L (GB457)
102 1012 01	Defrost Valve Coil (GB454/457/650)	102 1198 06	Comp. O/L (GB451)
102 1020 01	Liquid Cooled Condenser (GB450W)	102 1198 07	Comp. O/L (GB454)
102 1020 04	Marine Liquid Cooled Condenser (MGB650W)		

Parts List-Pictorial

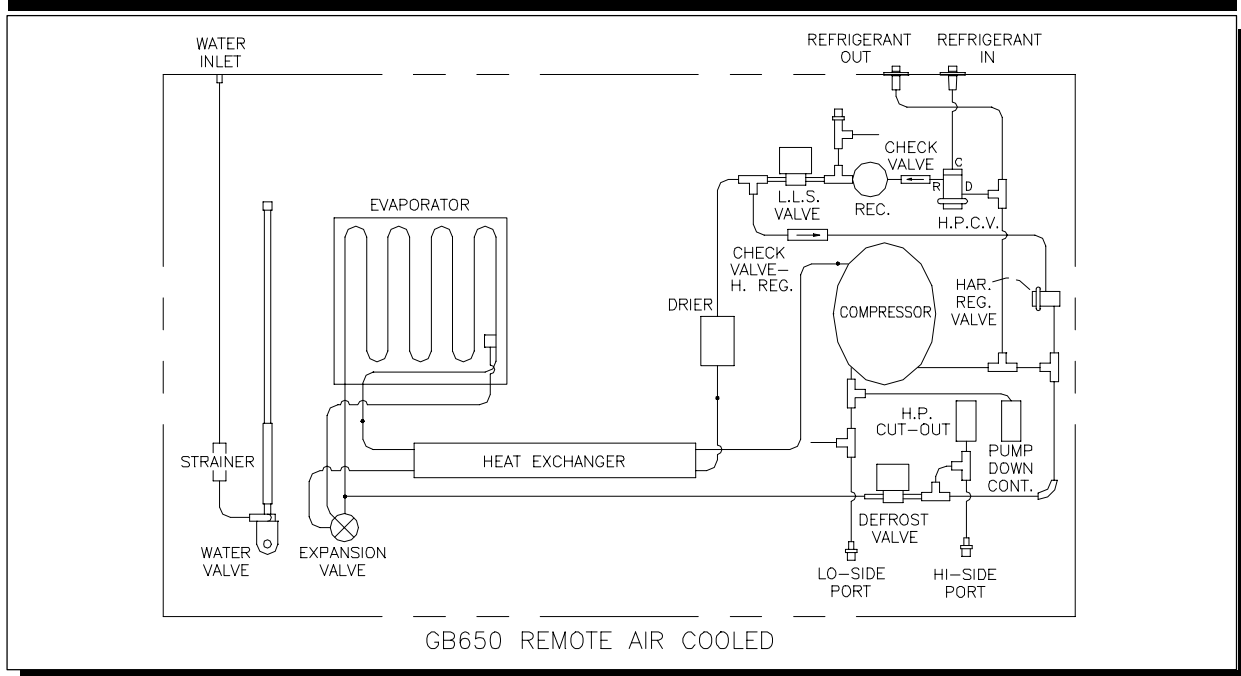

Part Number	Description	Part Number	Description
GBR-00148	Evaporator (C)	102 1012 01	Defr. & L.L. Sol. Valve Coil (GB454/650)
GBR-00153	Evaporator (K)	102 1023 01	Receiver
GBR-00167	Evaporator (HK)	102 1052 02	Pumpdown Control, direct connection (GB454/650R)
GBR-01376-FF	Water Valve (GB454/650)	102 1055 01	High Pressure Cutoff, Manual reset, R-404a
GBR-01379	Strainer	102 1071 01	Drier (GB454/650R)
GBR-01889	Refrigerant Inlet Fitting, 3/8"	102 1166 02	Check Valve, Harvest Regulator
GBR-01890	Refrigerant Discharge Fitting, 1/2"	102 1188 02	Expansion Valve (GB454)
GBR-02290	Check Valve	102 1191 26	Compressor (GB654)
GBR-02351	Head Press. Control Valve	102 1191 27	Compressor (GB657)
GBR-02359	Expansion Valve (GB650)	102 1191 31	Compressor (GB454)
102 1008 01	Defrost Valve Body (GB454)	102 1220 01	Harvest Regulator Valve
102 1010 01	Defrost (GB650) & L.L. Sol. Valve Body (GB454/650)	102 1253 01	Crankcase Heater (GB454/650R)

Parts List-Pictorial

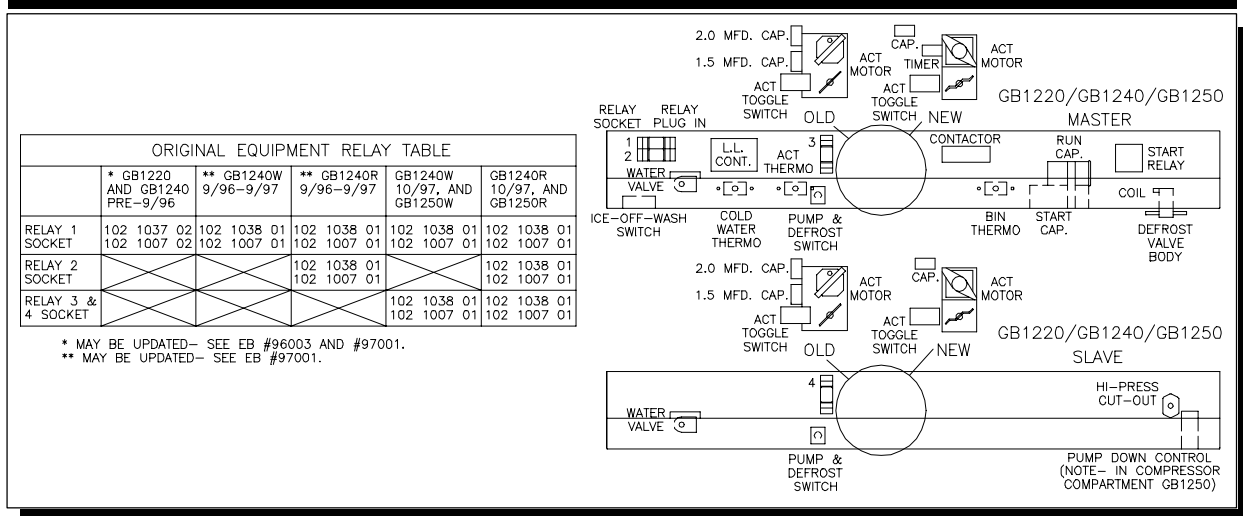

	* GB1220 AND GB1240 PRE-9/96	** GB1240W 9/96-9/97	** GB1240R 9/96-9/97	GB1240W 10/97, AND GB1250W	GB1240R 10/97, AND GB1250R
RELAY 1 SOCKET	102 1037 02 102 1007 02	102 1038 01 102 1007 01	102 1038 01 102 1007 01	102 1038 01 102 1007 01	102 1038 01 102 1007 01
RELAY 2 SOCKET					
RELAY 3 & 4 SOCKET				102 1038 01 102 1007 01	102 1038 01 102 1007 01

* MAY BE UPDATED- SEE EB #96003 AND #97001.
 ** MAY BE UPDATED- SEE EB #97001.

Part Number	Description	Part Number	Description
GBR-00813	Bin Thermo. 120" cap. tube	102 1036 01	Contactor, 1-pole (1 phase)
GBR-00814	Actuator Thermostat	102 1036 02	Contactor, 2-pole (3 phase)
GBR-00826	Capacitor 1.5 Mfd. <u>Old</u> act. motor	102 1037 02	Relay-Plug in, 3-pole (GB1220)
GBR-00837	Cold Water Thermostat	102 1038 01	Relay-Plug in, 2-pole (GB1240/1250)
GBR-00856	Bin Thermo. 66" cap. tube	102 1047 04	Start relay (GB1254)
GBR-00897	Actuator Toggle Switch	102 1052 02	Pump-down cont., direct connection (GB1250R)
GBR-00972	Act. Motor <u>Old</u> (GB1220 Master), OBS.	102 1053 01	ICE-OFF-WASH Switch
GBR-01376-FF	Water Valve	102 1055 01	High Pressure Cutoff, Manual reset, R-502/404a
GBR-01395-05	Run Cap. (GB1224)	102 1142 01	Liquid Level Control
GBR-02353-01	Start relay (GB1224/1244)	102 1195 05	Start Cap. (GB1244)
GBR-02353-02	Start Cap. (GB1224)	102 1195 09	Start Cap. (GB1254)
GBR-03110-01	Modified Rotor (GB1220 Master) <u>Old</u> Master act. motor	102 1197 05	Run Cap. (GB1244)
GBR-03153	Actuator Motor <u>Old</u> , Slave OBS	102 1197 06	Run Cap. (GB1254)
GBR-03370	Pump Down Cont., Cap. tube connection (GB1220/1240R)	102 1217 01	P. & D. Switch (Master & Slave)
102 1007 01	Relay Socket, 2-pole (GB1240/1250)	102 1223 01	Capacitor 2.0 Mfd. <u>Old</u> act. motor
102 1007 02	Relay Socket, 3-pole (GB1220)	102 1292 02	Act. Motor, <u>New</u> , 2 required
102 1010 01	Defrost Valve Body	102 1239 02	Master Actuator Motor Timer, <u>New</u>
102 1012 01	Defrost Valve Coil	102 1241 02	Actuator Motor Capacitor, 1 Mfd., <u>New</u>

Parts List-Pictorial

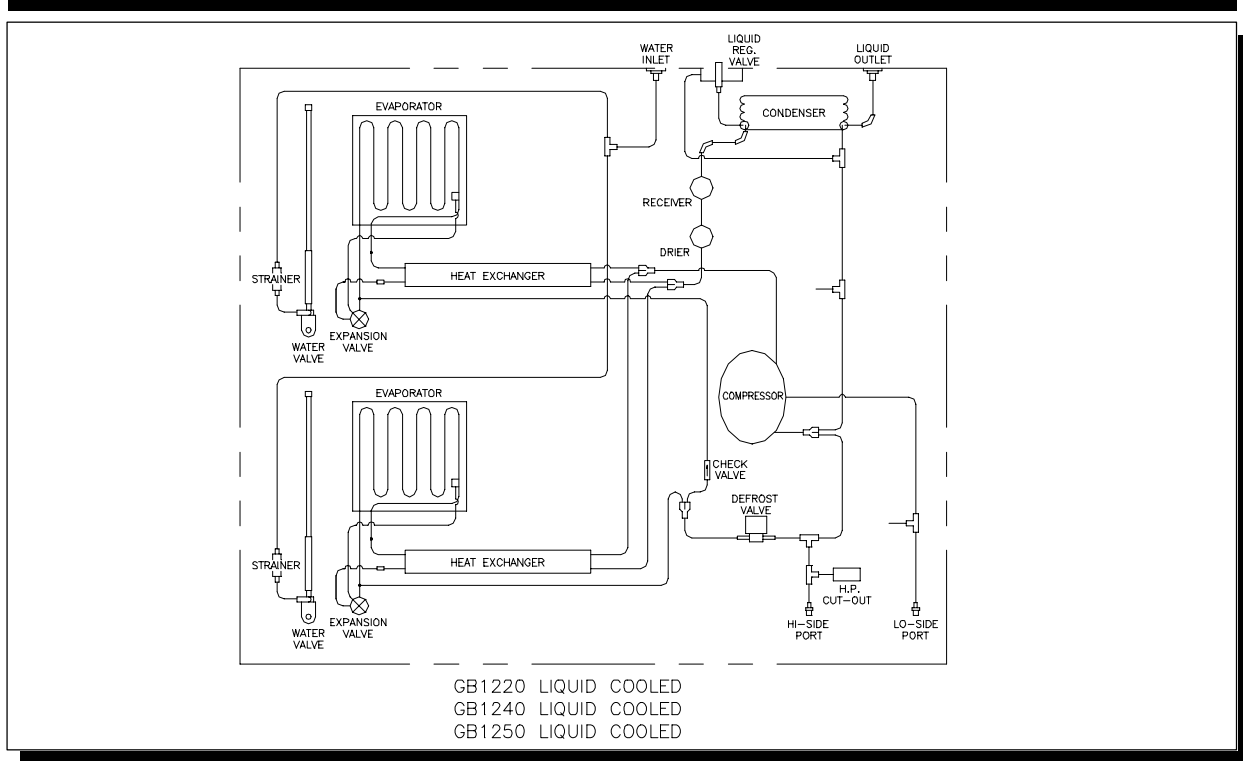

Part Number	Description	Part Number	Description
GAR-00701-D	Liquid Regulator Valve	102 1012 01	Defrost Valve Coil
GBR-00148	Evaporator (C)	102 1020 02	Liquid Cooled Condenser
GBR-00153	Evaporator (K)	102 1055 01	High Pressure Cutoff, Manual reset, R-502/404a
GBR-00167	Evaporator (HK)	102 1071 01	Drier
GBR-01376-FF	Water Valve	102 1191 22	Compressor (GB1254)
GBR-01379	Strainer	102 1191 23	Compressor (GB1255)
GBR-02290	Check Valve	102 1191 30	Compressor (GB1258)
GBR-02343	Receiver	102 1242 09	Comp. Repl. Kit (GB1224/1244 Br. to Tec.)
GBR-02359	Expansion Valve	102 1242 10	Comp. Repl. Kit (GB1225/1245 Br. to Tec.)
102 1010 02	Defrost Valve Body		

Parts List-Pictorial

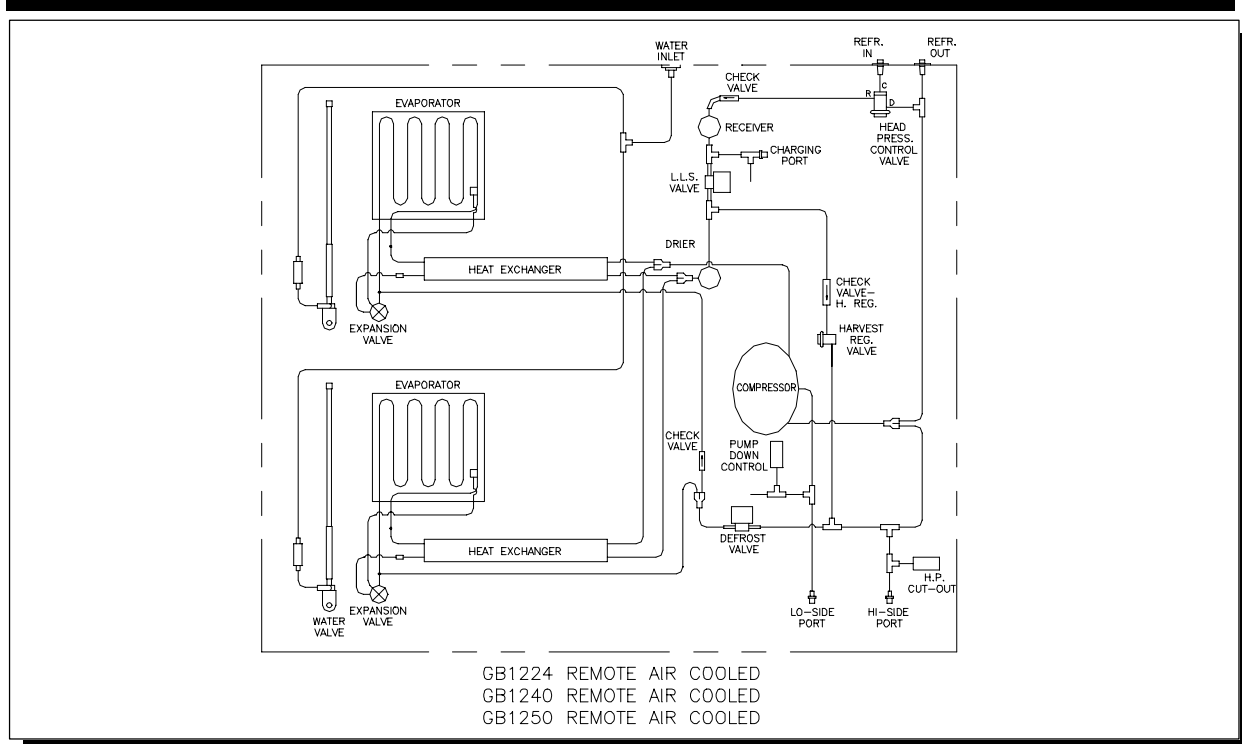

Part Number	Description	Part Number	Description
GBR-00148	Evaporator (C)	102 1012 01	Defrost & Liquid Line Solenoid Coil
GBR-00153	Evaporator (K)	102 1023 02	Receiver
GBR-00167	Evaporator (HK)	102 1052 02	Pump-down control, direct connection (GB1250R)
GBR-01376-FF	Water Valve	102 1055 01	High Pressure Cutoff, Manual reset, R-502/404a
GBR-01379	Strainer	102 1071 01	Drier
GBR-01889	Refrigerant Inlet Fitting 3/8"	102 1166 02	Check Valve, Harvest Regulator
GBR-01890	Refrigerant Discharge Fitting 1/2"	102 1191 22	Compressor (GB1254)
GBR-02290	Check Valve	102 1191 23	Compressor (GB1255)
GBR-02351	Head Press. Control Valve	102 1191 30	Compressor (GB1258)
GBR-02359	Expansion Valve	102 1220 01	Harvest Regulator Valve
GBR-03370	Pump Down Control, Cap. tube connection (GB1220/1240R)	102 1242 09	Comp. Repl. Kit (GB1224/1244 Br. to Tec.)
102 1010 01	Liquid Line Solenoid Valve Body	102 1242 10	Comp. Repl. Kit (GB1225/1245 Br. to Tec.)
102 1010 02	Defrost Valve Body		

Parts List-Pictorial

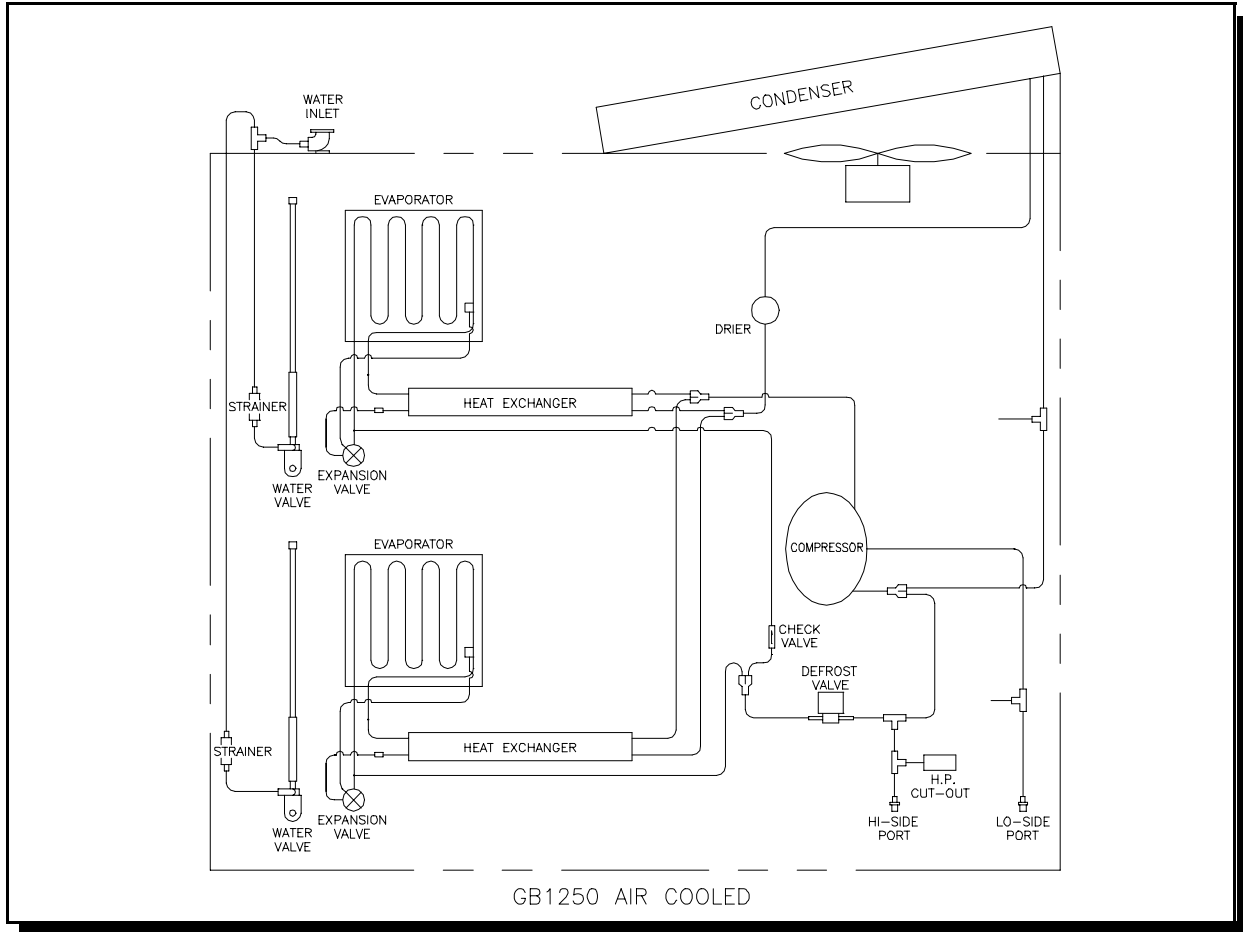

Part Number	Description	Part Number	Description
GBR-00148	Evaporator (C)	102 1018 02	Air Cooled Condenser (2 Required)
GBR-00153	Evaporator (K)	102 1055 01	High Pressure Cutoff, Manual reset, R-404a
GBR-00167	Evaporator (HK)	102 1071 01	Drier
GBR-01376-FF	Water Valve	102 1191 22	Compressor (GB1254)
GBR-01379	Strainer	102 1191 23	Compressor (GB1255)
GBR-02290	Check Valve	102 1191 30	Compressor (GB1258)
GBR-02359	Expansion Valve	102 1214 04	Fan Support (2 Required)
102 1010 02	Defrost Valve Body	102 1274 01	Fan Motor (2 Required)
102 1012 01	Defrost Valve Coil	102 1275 01	Fan Blade (2 Required)

Parts List-Pictorial

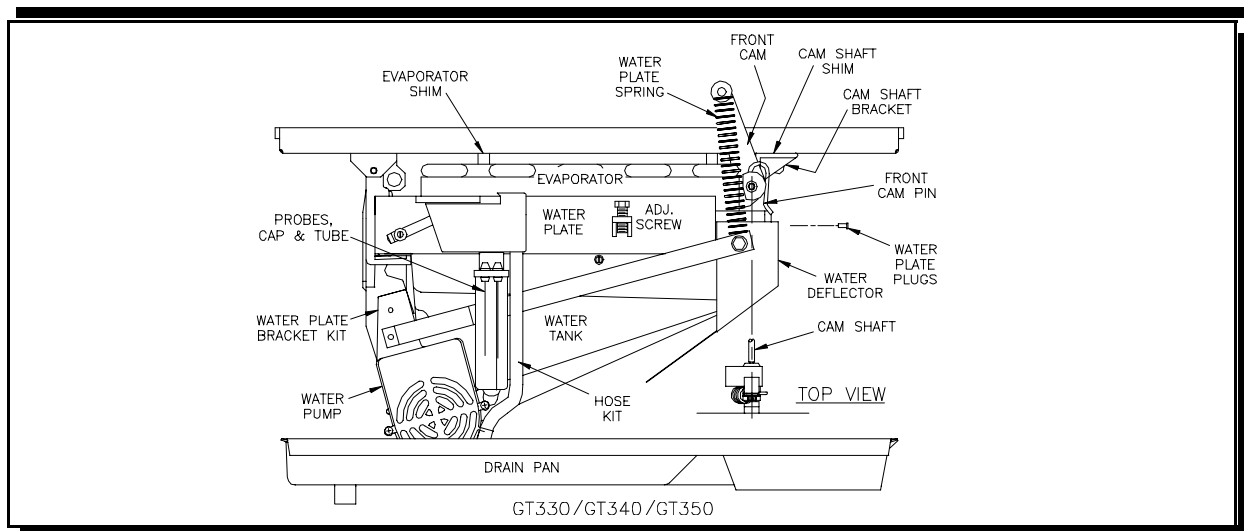

Part Number	Description	Part Number	Description
GBR-00111	Evaporator Shim (10)	GYR-00201	Water Tank
GBR-00113	Evaporator Spacer, "C" or "HK", 4 req'd. (not shown)	GYR-00202	Water Deflector
GBR-00126	Evaporator Spacer, "K", 4 req'd. (not shown)	GYR-00219	Water Tank Screen (not shown)
GBR-00223	Water Plate Plugs (12)	102 1025 02	Evaporator (C)
GBR-00282-06	Water Plate Bracket Kit (front & rear)	102 1025 03	Evaporator (HK)
GBR-00580	Cam Shaft Shim (2 thin-2 thick)	102 1025 04	Evaporator (K)
GBR-00909	Water Plate Spring (2 req'd.)	102 1100 02	Drain Pan/Chute, Bottom Drain
GBR-00937	Cam Shaft Bracket- Rear (1 req.)	102 1100 03	Drain Pan/Chute (Multiplex)
GBR-00949	Rear Cam (not shown)	Click Here	Water Pump (GT334/344/354)
GBR-00951	Water Plate Spring Boss	102 1154 02	Water Distrib. Tube Kit
GBR-00969	Front Cam	102 1201 01	Drain Tube, Bottom drain
GBR-02087	Hose Kit	102 1210 01	Front Cam Pin (5)
GBR-03230	Adjusting Screw	102 1216 02	Probes, Cap & Tube
Click Here	Water Pump (GT331/341/351)	102 1221 01	Cam Shaft
Click Here	Water Pump (GT337/347/357)	102 1222 01	Cam Shaft Bracket-Front (1 req.)
GTR-00221	Water Plate (C)	102 1290 01	Drain Tube, Back drain
GTR-00222	Water Plate (HK & K)	102 1291 01	Drain Pan/Chute, Back drain

Parts List-Pictorial

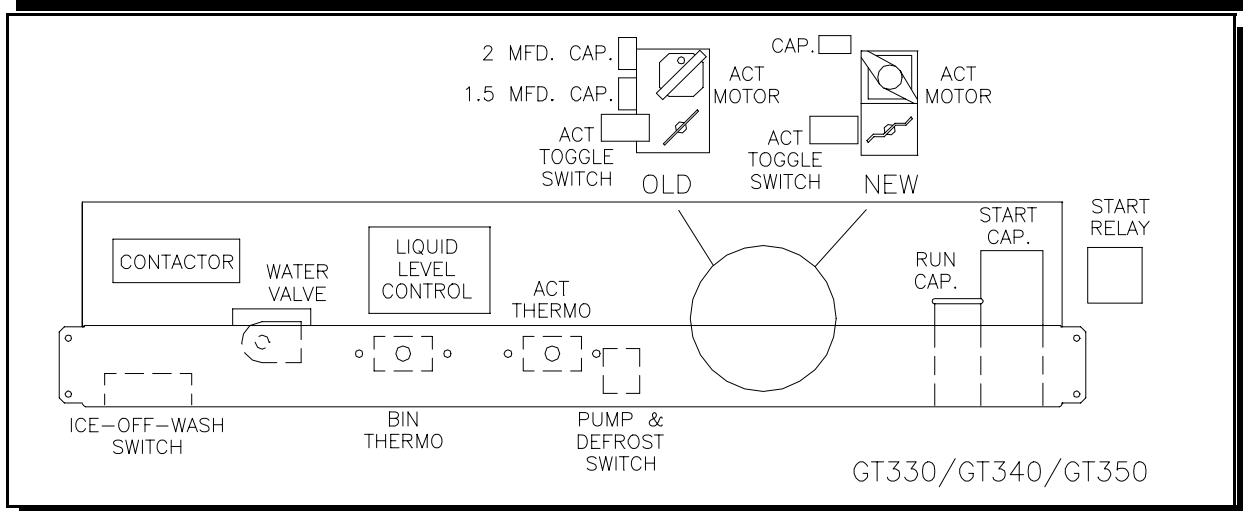

Part Number	Description	Part Number	Description
GBR-00813	Bin Thermo. 120" cap. tube	102 1142 01	L. L. Control (GT334/337/344/347/354/357)
GBR-00814	Actuator Thermostat	102 1180 02	Actuator Motor <u>Old</u>
GBR-00826	Capacitor 1.5 Mfd. <u>Old</u> act. motor	102 1195 02	Start Cap. (GT354/357)
GBR-00856	Bin Thermo. 66" cap. tube	102 1195 03	Start Cap. (GT331/337/341/347)
GBR-00897	Actuator Toggle Switch	102 1195 06	Start Cap. (GT334/344)
GYR-00361	Wtr. Valve (GT331/341/351)	102 1195 08	Start Cap. (GT351)
GYR-00362-FF	Water Valve (GT334/337/344/347/354/357)	102 1196 01	St. Cap. (GT337)
102 1035 01	Contactor (GT331/341/351)	102 1197 04	Run Cap. (GT337/351)
102 1036 01	Contactor (GT334/337/344/347/354/357)	102 1206 01	L.L.Cont. (GT331/341/351)
102 1044 01	Run Cap (GT331/334/341/344/354/357)	102 1217 01	P. & D. Switch
102 1047 03	Start relay (GT337)	102 1223 01	Capacitor 2.0 Mfd., <u>Old</u> act. motor (GT334/344)
102 1047 04	Start relay (GT331/341)	102 1238 01	Act. Motor <u>New</u> (GT331/341/351)
102 1047 06	Start relay (GT334/344/354)	102 1238 02	Act. Motor <u>New</u> (GT334/337/344/347/354/357)
102 1047 09	Start relay (GT351)	102 1241 01	Cap. 4 Mfd., <u>New</u> (GT331/341/351)
102 1047 10	Relay (GT357)	102 1241 02	Cap. 1 Mfd. <u>New</u> (GT334/337/344/347/354/357)
102 1053 01	ICE-OFF-WASH Switch		

Parts List-Pictorial

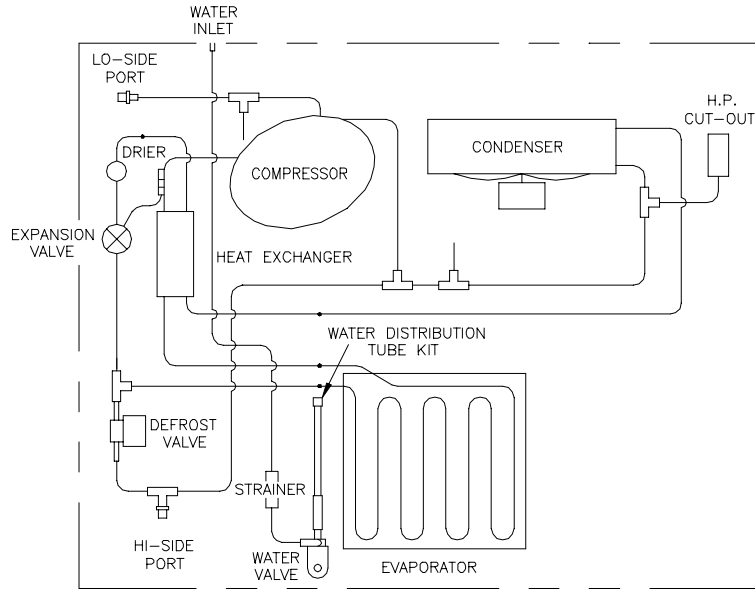

GT330/GT340/GT350 AIR COOLED

Part Number	Description	Part Number	Description
GBR-01353	Air Cooled Condenser	102 1055 01	High Pressure Cutoff, Manual reset, R-502/404a
GBR-01379	Strainer	102 1154 02	Water Distribution Tube Kit
GBR-02750	Drier	102 1188 02	Expansion Valve
GYR-00361	Water Valve (GT331/341/351)	102 1191 24	Compressor (GT351)
GYR-00362-FF	Water Valve (GT334/337/344/347/354/357)	102 1191 25	Compressor (GT357)
102 1008 01	Defrost Valve Body	102 1191 32	Compressor (GT354)
102 1011 01	Coil (GT331/341/351)	102 1198 02	Comp. O/L (GT351)
102 1012 01	Coil (GT334/337/344/347/354/357)	102 1198 04	Comp. O/L (GT357)
102 1014 01	Fan Motor (GT331/341/351)	102 1198 08	Comp. O/L (GT354)
102 1014 02	Fan Motor (GT337/347/357)	102 1214 02	Fan Support
102 1015 01	Fan Motor (GT334/344/354)	102 1215 03	Fan Shroud
102 1016 02	Fan Blade	102 1242 11	Comp. Repl. Kit (GT331/341)
102 1025 02	Evaporator (C)	102 1242 12	Comp. Repl. Kit (GT334/344)
102 1025 03	Evaporator (HK)	102 1242 13	Comp. Repl. Kit (GT337/347)
102 1025 04	Evaporator (K)		

Parts List-Pictorial

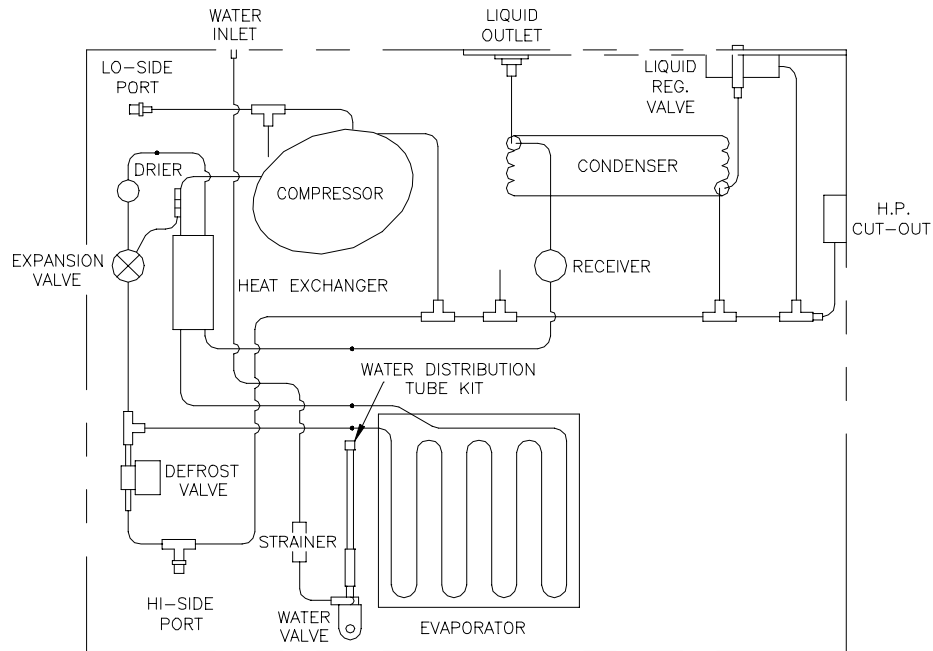

GT330/GT340/GT350 LIQUID COOLED

Part Number	Description	Part Number	Description
GAR-00701-D	Liquid Regulator Valve	102 1055 01	High Pressure Cutoff, Manual reset, R-502/404a
GBR-01379	Strainer	102 1066 01	Receiver
GBR-02750	Drier	102 1154 02	Water Distribution Tube Kit
GYR-00361	Water Valve (GT331/341/351)	102 1188 02	Expansion Valve
GYR-00362-FF	Water Valve (GT334/337/344/347/354/357)	102 1191 24	Compressor (GT351)
102 1008 01	Defrost Valve Body	102 1191 25	Compressor (GT357)
102 1011 01	Coil (GT331/341/351)	102 1191 32	Compressor (GT354)
102 1012 01	Coil (GT334/337/344/347/354/357)	102 1198 02	Comp. O/L (GT351)
102 1020 03	Liquid Cooled Condenser	102 1198 04	Comp. O/L (GT357)
102 1020 06	Marine Liquid Cooled Condenser (MGT3XXW)	102 1198 08	Comp. O/L (GT354)
102 1025 02	Evaporator (C)	102 1242 11	Comp. Retro. Kit (GT331/341)
102 1025 03	Evaporator (HK)	102 1242 12	Comp. Retro. Kit (GT334/344)
102 1025 04	Evaporator (K)	102 1242 13	Comp. Retro. Kit (GT337/347)

Parts List-Pictorial

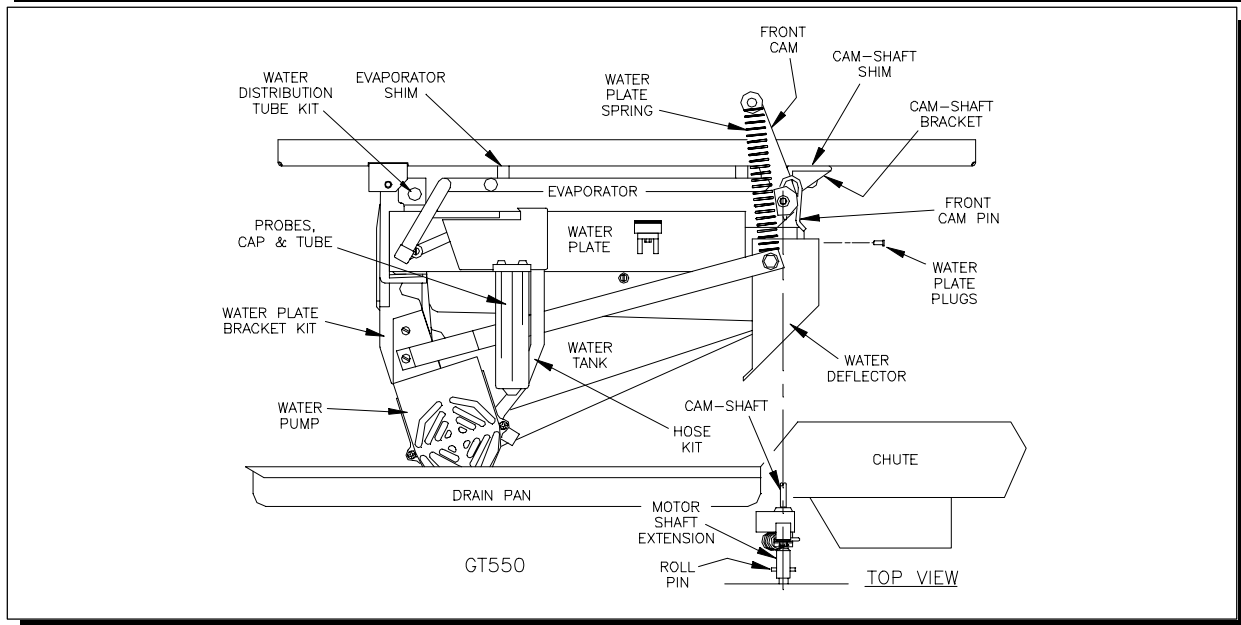

Part Number	Description	Part Number	Description
GAR-00203	Water Tank	GBR-00580	Cam Shaft Shim (2 thin-2 thick)
GBR-00111	Evaporator Shim (10)	GBR-00909	Water Plate Spring (2 req'd.)
GBR-00113	Evaporator Spacer, "C", or "HK", 4 req'd. (not shown)	GBR-00937	Cam Shaft Bracket (2 req'd.)
GBR-00126	Evaporator Spacer, "K", 4 req'd. (not shown)	GBR-00942	Cam Shaft
GBR-00148	Evaporator (C)	GBR-00949	Rear Cam (not shown)
GBR-00153	Evaporator (K)	GBR-00951	Water Plate Spring Boss
GBR-00167	Evaporator (HK)	GBR-00959	Roll Pin (10)
GBR-00200	Water Plate (C)	GBR-00969	Front Cam
GBR-00202	Water Deflector	GBR-02087	Hose Kit
Click Here	Water Pump (GT551)	102 1100 04	Drain Pan
GBR-00223	Water Plate Plugs (12)	102 1100 05	Chute
GBR-00245	Water Tank Screen (not shown)	Click Here	Water Pump (GT554)
GBR-00270	Water Plate (HK & K)	102 1209 01	Motor Shaft Extension
GBR-00282-06	Water Plate Bracket Kit (front & rear)	102 1210 01	Front Cam Pin (5)
GBR-00403	Water Distrib. Tube Kit	102 1216 01	Probes, Cap & Tube

Parts List-Pictorial

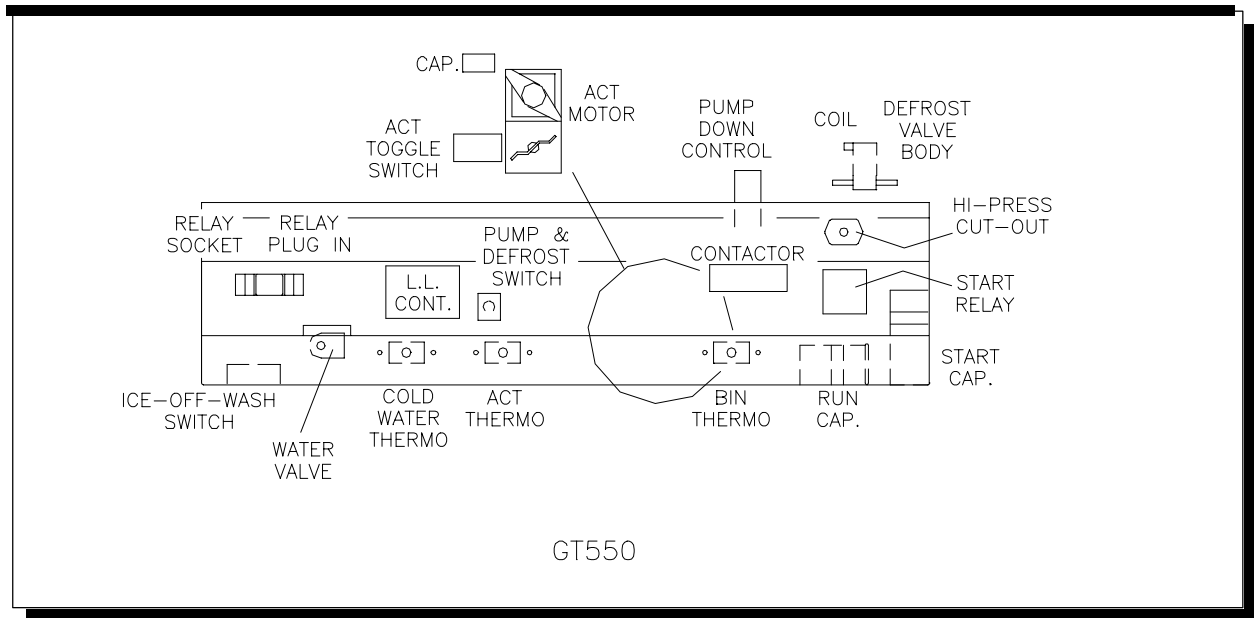

Part Number	Description	Part Number	Description
GBR-00813	Bin Thermo. 120" cap. tube, long	102 1044 01	Run Capacitor (GT554)
GBR-00814	Actuator Thermostat	102 1047 09	Start Relay (GT551)
GBR-00837	Cold Water Thermostat	102 1047 14	Start Relay (GT554)
GBR-00856	Bin Thermo. 66" cap. tube	102 1052 02	Pump-down Controller, Direct connection (GT550R)
GBR-00897	Actuator Toggle Switch	102 1053 01	ICE-OFF-WASH Switch
GBR-01375	Water Valve, 120V coil (GT551)	102 1055 01	High Pressure Cutoff, Man. reset (Cap. tube)
GBR-01376-FF	Water Valve, 240V coil (GT554)	102 1142 01	Liq. Level Cont., 230 Volt (GT554)
GBR-03370	Pump-Down Cont., Cap. tube connection (GT550R)	102 1195 02	Start Cap. (GT554)
102 1007 01	Relay Socket (GT550R)	102 1195 08	Start Cap. (GT551)
102 1010 01	Defrost Valve Body	102 1197 04	Run Cap. (GT551)
102 1011 01	Defrost Valve Coil , 120 Volt (GT551)	102 1206 01	Liq. Level Cont., 115 Volt (GT551)
102 1012 01	Defrost Valve Coil , 240 Volt (GT554)	102 1217 01	Pump & Defrost Switch
102 1035 01	Contactor, 120 Volt Coil (GT551)	102 1292 01	Act. Motor, 115 Volt (GT551)
102 1036 01	Contactor, 240 Volt Coil (GT554)	102 1292 02	Act. Motor, 230 Volt (GT554)
102 1037 01	Relay-Plug in , 120 Volt coil (GT551R)	102 1241 01	Cap, 4 mfd, 115V Act Motor (GT551)
102 1038 01	Relay-Plug in , 240 Volt coil (GT554R)	102 1241 02	Cap, 1 mfd, 230V Act Motor (GT554)

Parts List-Pictorial

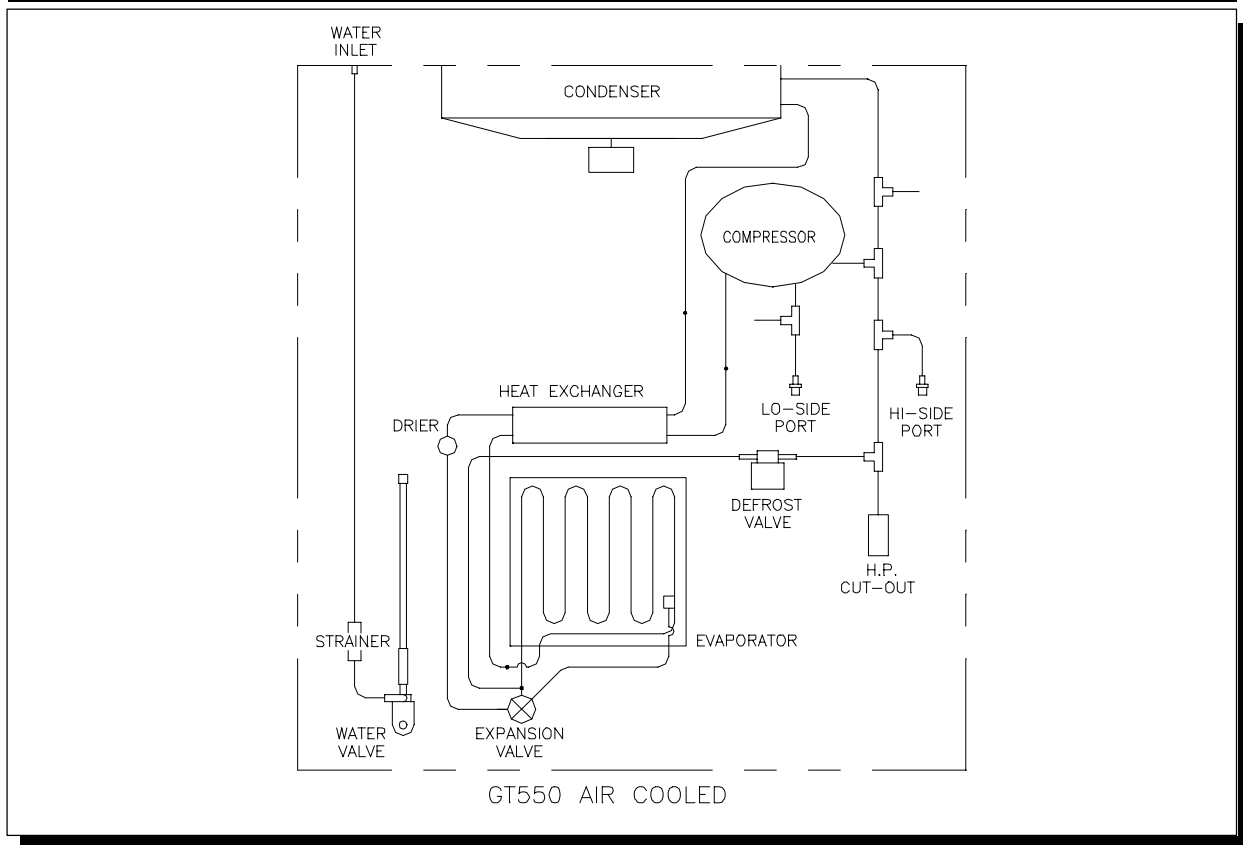

Part Number	Description	Part Number	Description
GBR-00148	Evaporator (C)	102 1014 01	Fan Motor, 115V(GT551A)
GBR-00153	Evaporator (K)	102 1015 01	Fan Motor, 230V(GT554A)
GBR-00167	Evaporator (HK)	102 1016 02	Fan Blade
GBR-01375	Water Valve, 120V (GT551)	102 1018 03	Air Cooled Condenser
GBR-01376-FF	Water Valve, 240V (GT554)	102 1055 01	High Pressure Cutoff, Manual reset, R-404a
GBR-01379	Strainer	102 1191 21	Compressor (GT551)
GBR-02359	Expansion Valve	102 1191 33	Compressor (GT554)
GBR-02750	Drier	102 1198 03	Comp. O/L (GT551)
102 1010 01	Defrost Valve Body	102 1198 07	Comp. O/L (GT554)
102 1011 01	Def. Valve Coil, 120V(GT551)	102 1214 01	Fan Support
102 1012 01	Def. Valve Coil, 240V(GT554)	102 1215 04	Fan Shroud

Parts List-Pictorial

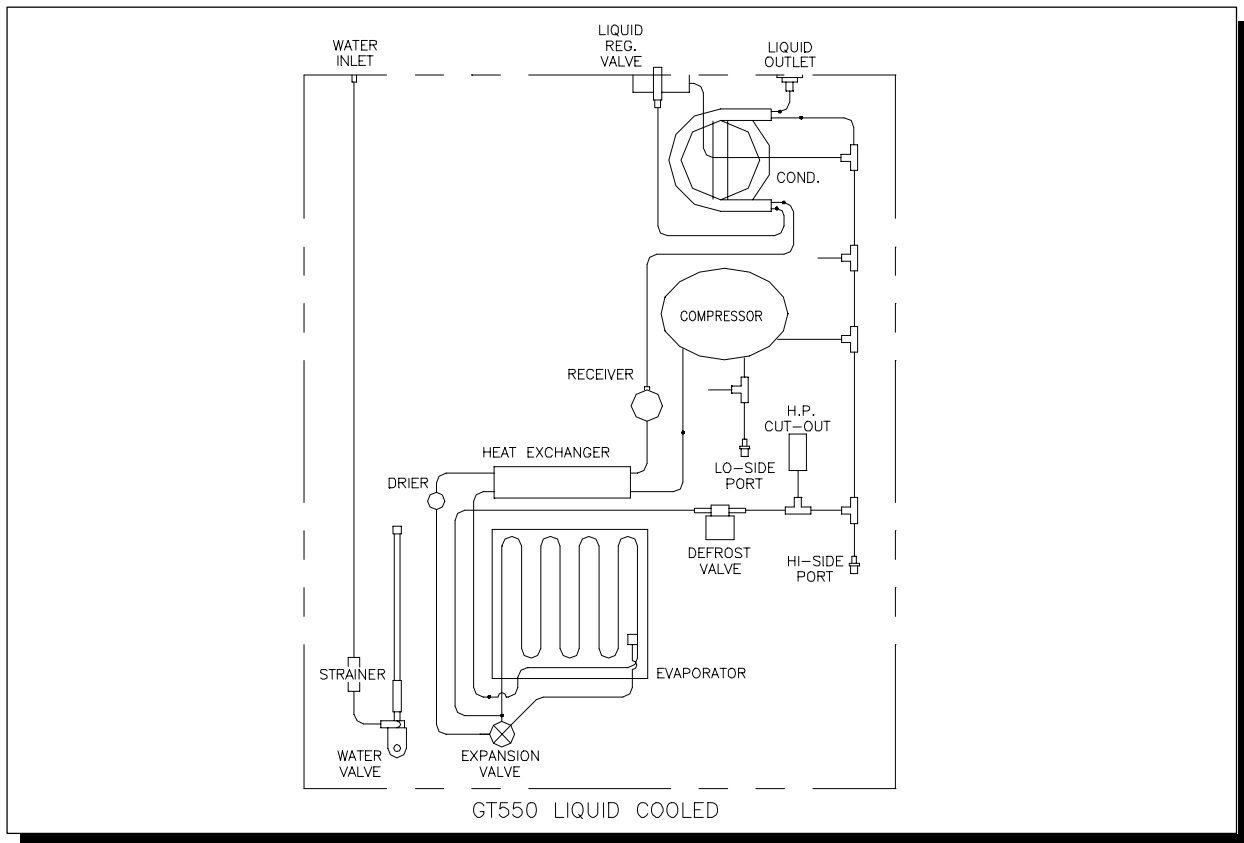

Part Number	Description	Part Number	Description
GAR-00701-D	Liquid Regulator Valve	102 1011 01	Def. Valve Coil,120V(GT551)
GBR-00148	Evaporator (C)	102 1012 01	Def. Valve Coil,240V(GT554)
GBR-00153	Evaporator (K)	102 1020 01	Liquid Cooled Condenser
GBR-00167	Evaporator (HK)	102 1020 05	Marine Liquid Cooled Condenser (MGT550W)
GBR-01375	Water Valve, 120V (GT551)	102 1055 01	High Pressure Cutoff, Manual reset, R-404a
GBR-01376-FF	Water Valve, 240V (GT554)	102 1066 01	Receiver
GBR-01379	Strainer	102 1191 21	Compressor (GT551)
GBR-02359	Expansion Valve	102 1191 33	Compressor (GT554)
GBR-02750	Drier	102 1198 03	Comp. O/L (GT551)
102 1010 01	Defrost Valve Body	102 1198 07	Comp. O/L (GT554)

Parts List-Pictorial

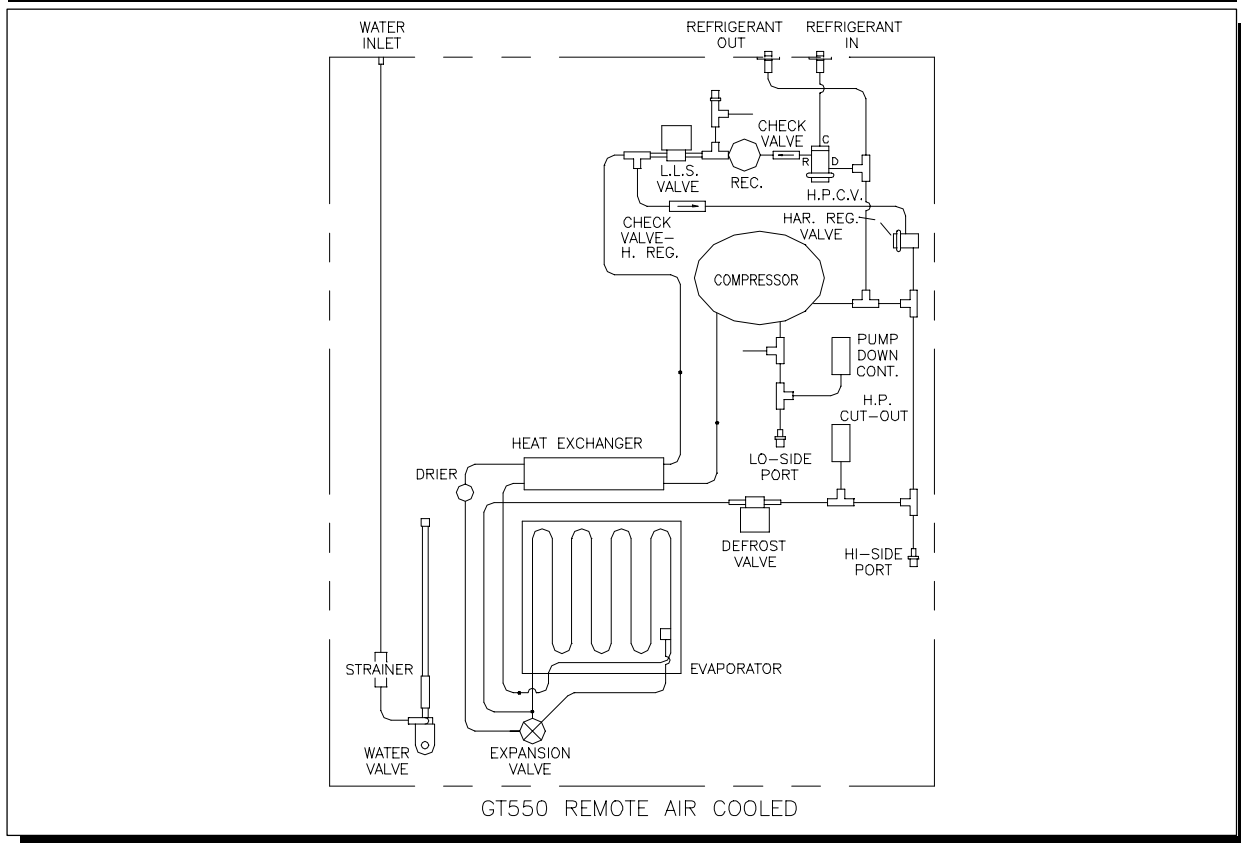

Part Number	Description	Part Number	Description
GBR-00148	Evaporator (C)	102 1011 01	Defrost & L.L. Solenoid Valve Coil, 120V (GT551R)
GBR-00153	Evaporator (K)	102 1012 01	Defrost & L.L. Solenoid Valve Coil, 240V (GT554R)
GBR-00167	Evaporator (HK)	102 1023 01	Receiver
GBR-01375	Water Valve, 120V (GT551)	102 1052 02	Pump Down Control, Direct connection
GBR-01376-FF	Water Valve, 240V (GT554)	102 1055 01	High Pressure Cutoff, Manual reset, R-404a
GBR-01379	Strainer	102 1071 01	Drier
GBR-01889	Refrigerant Inlet Fitting 3/8"	102 1166 02	Check Valve-Harvest Regulator
GBR-02290	Check Valve	102 1191 21	Compressor (GT551)
GBR-02351	Head Press. Control Valve	102 1191 33	Compressor (GT554)
GBR-02359	Expansion Valve	102 1198 03	Comp. O/L (GT551)
GBR-03370	Pump Down Control, Cap. tube connection	102 1198 07	Comp. O/L (GT554)
102 1010 01	Defrost & L.L. Solenoid Valve Body	102 1220 01	Harvest Regulator Valve

Parts List-Pictorial

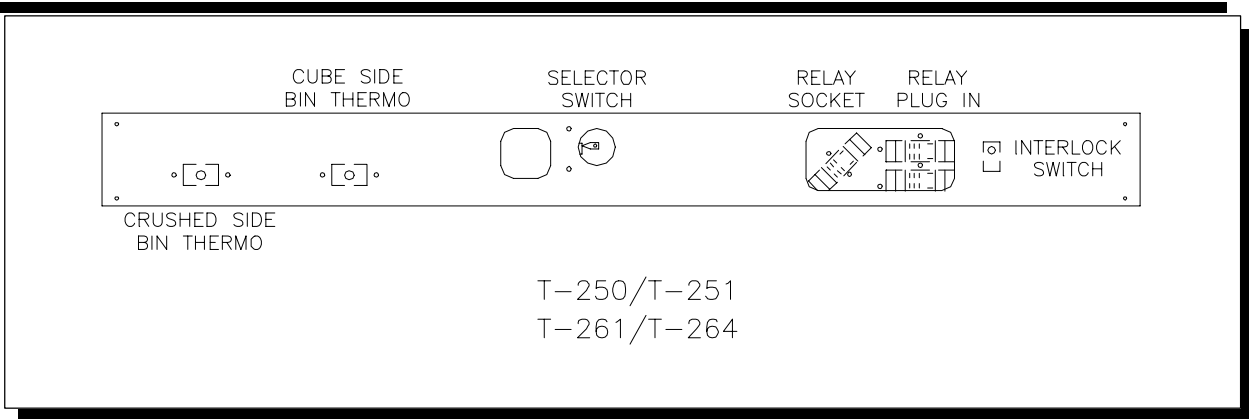

Part Number	Description
GBR-00856	Crusher & Cube Side Bin Thermostat
102 1007 01	Relay Socket
102 1037 01	Relay-Plug in (T-251/T-261)
102 1038 01	Relay-Plug in (T-250/T-264)
102 1217 04	Selector Switch
102 1217 03	Interlock Switch

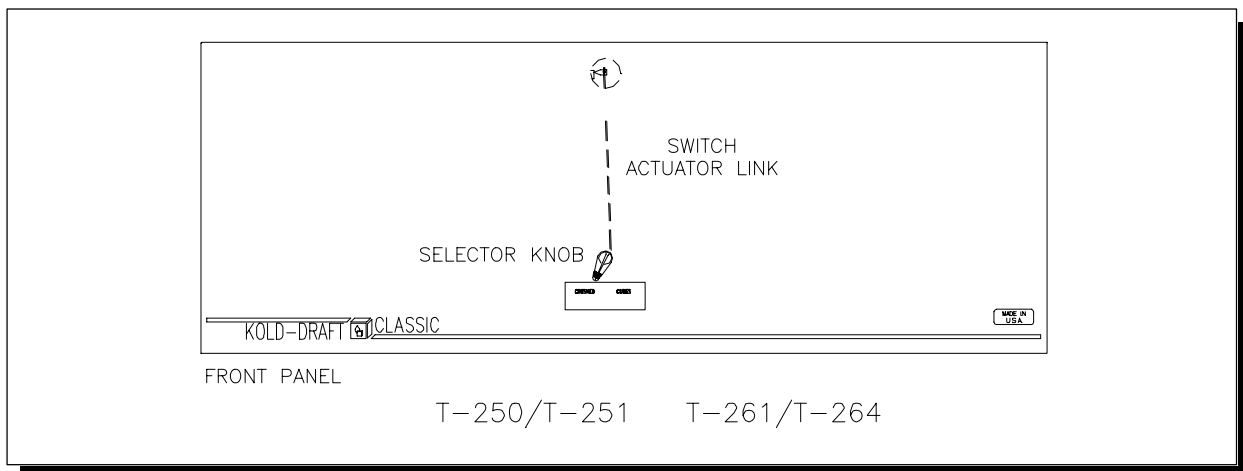

Part Number	Description
102 1202 04	Front Panel
102 1225 01	Selector Knob
102 1226 01	Switch Actuator Link

Parts List-Pictorial

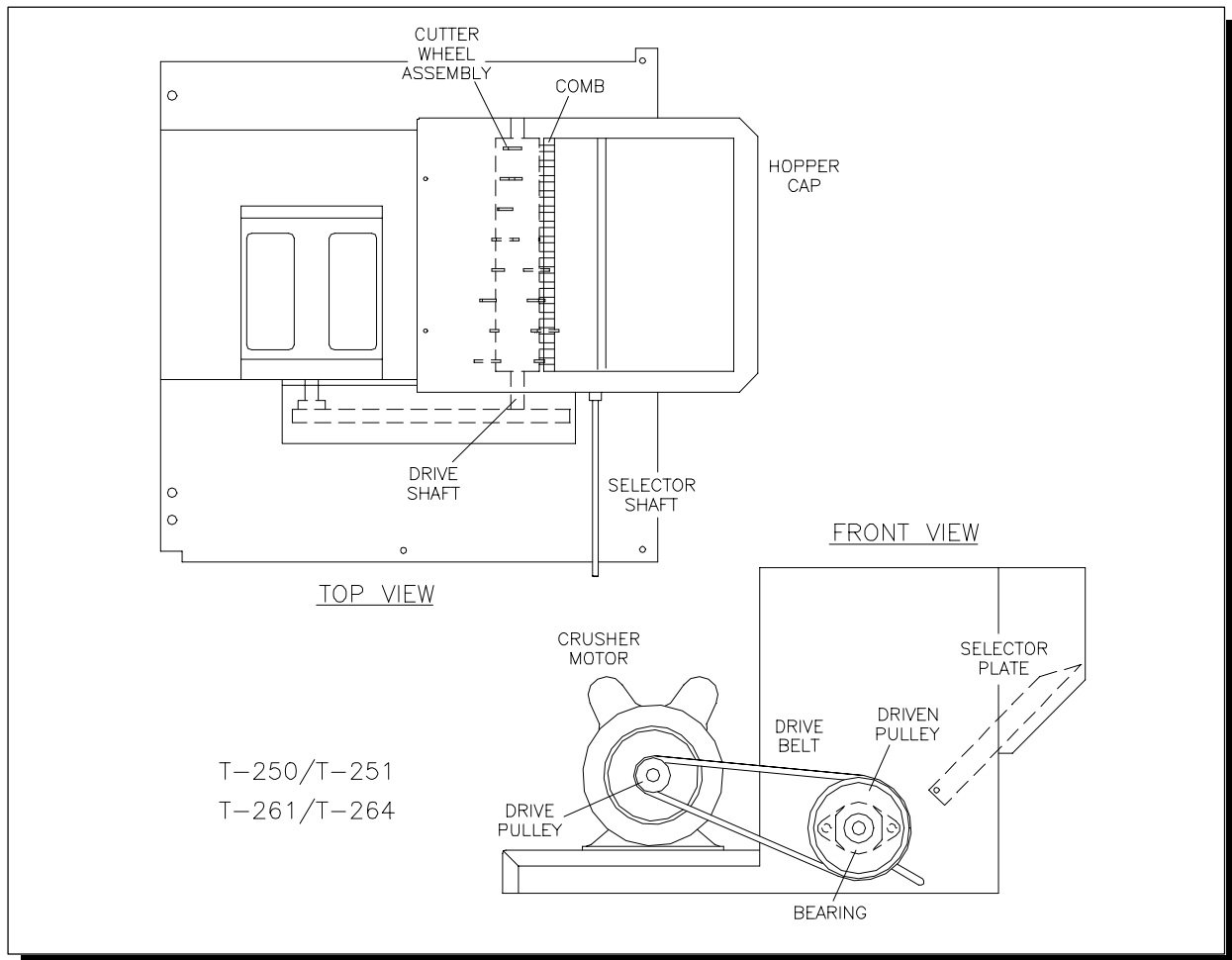

Part Number	Description
102 1133 02	Crusher Motor
102 1148 02	Drive Pulley-24 Tooth (T-250/T-251)
102 1148 03	Driven Pulley-72 Tooth (T-250/T-251)
102 1150 02	Drive Belt (T-250/T-251)
102 1152 02	Bearing (2 req'd.) (T-250/T-251)
102 1221 02	Selector Shaft
102 1221 03	Drive Shaft
102 1227 01	Hopper Cap
102 1230 01	Comb
102 1231 01	Selector Plate
102 1257 01	Drive Pulley-13 Tooth (T-261/T-264)
102 1258 01	Driven Pulley-36 Tooth (T-261/T-264)
102 1259 01	Drive Belt (T-261/T-264)
102 1260 01	Bearing (2-req'd.) (T-261/T-264)
102 1261 01	Cutter Wheel Assembly (Fits All)

Parts List-Pictorial

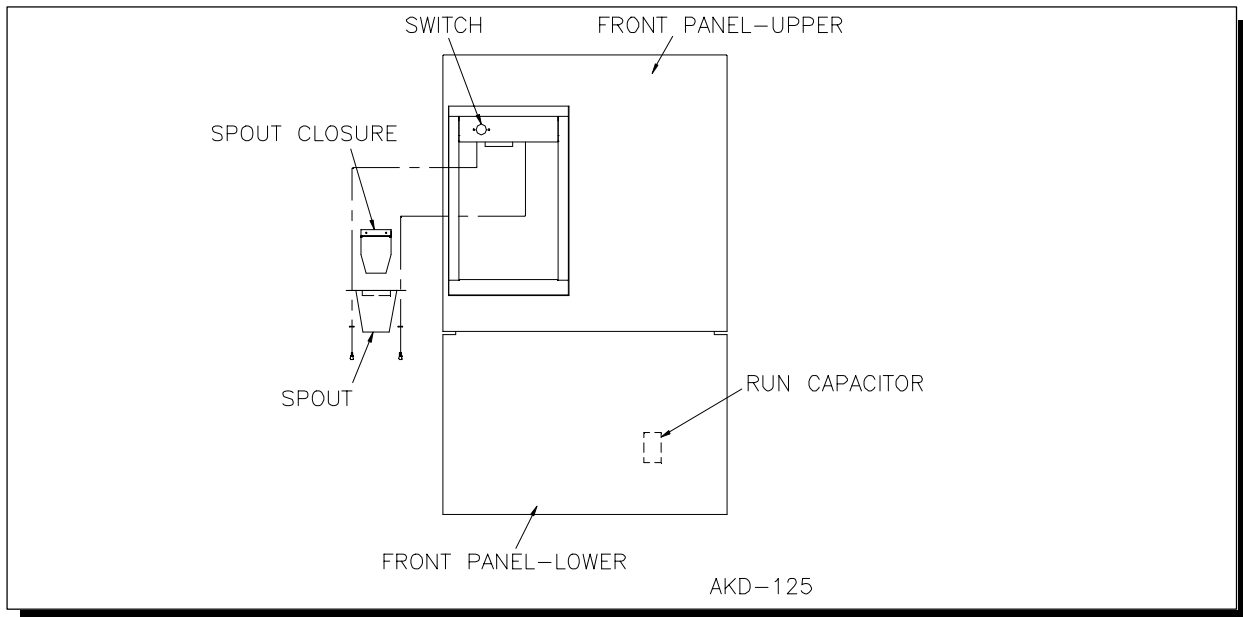

Part Number	Description
GBR-00894	Transformer (AKD-125-FF) (Not Shown)
TTR-05144	Push Button Switch
102 1197 04	Run Capacitor
102 1202 05	Front Panel-Upper
102 1202 06	Front Panel-Bottom
102 1243 01	Spout
102 1244 01	Spout Closure

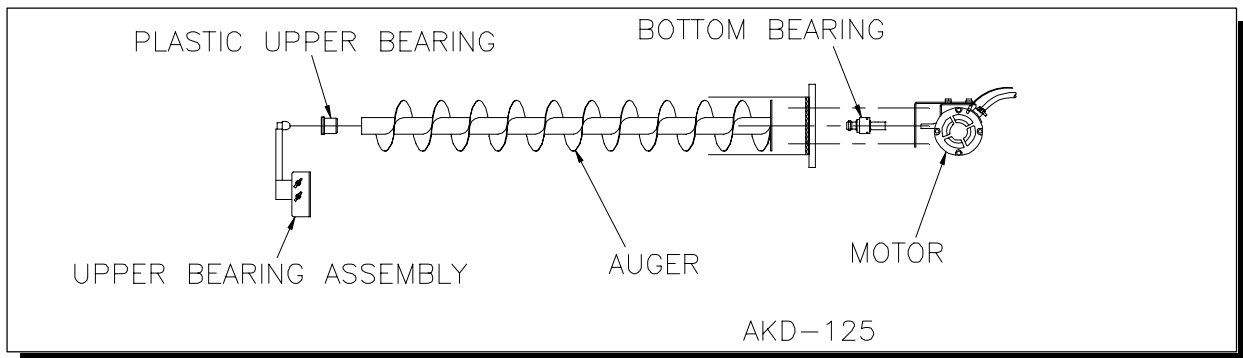

Part Number	Description
TTR-02698	Gearmotor
TTR-02711	Upper Bearing Assembly
TTR-02716	Auger
TTR-02717	Plastic Upper Bearing
102 1245 01	Bottom Bearing Assembly

Parts List-Numerical

Part Number	Description
GAR-00203	Water Tank (GB/GT550)
GAR-00701-D	Liquid Coolant Regulator Valve (Water-cooled)
GBR-00111	Evaporator Shim (10)
GBR-00113	Evaporator Spacer, "C" or "HK", 4 required
GBR-00126	Evaporator Spacer, "K", 4 required
GBR-00148	Evaporator (All GB/GT550, "C")
GBR-00153	Evaporator (All GB/GT550, "K")
GBR-00167	Evaporator (All GB/GT550 "HK")
GBR-00200	Water Plate (All GB/GT550 "C")
GBR-00202	Water Deflector (All GB/GT550)
Click Here	Water Pump, 115/60 (GB421/431/441/451/GT551)
Click Here	Water Pump, 220-240/50 (GB427/437/447/457/627/637/647/657)
GBR-00223	Water Plate Plugs (12)
GBR-00245	Water Tank Outlet Screen (All GB/GT550)
GBR-00270	Water Plate (All GB/GT551 "HK" & "K")
GBR-00282-06	Water Plate Bracket Kit (front & rear)
GBR-00403	Water Distribution Tube Kit (All GB/GT550)
GBR-00580	Cam Shaft Shim (2 thin-2 thick)
GBR-00668	Ice Chute, GB only
GBR-00813	Bin Thermostat 120" cap. tube (extra long when required)
GBR-00814	Actuator Thermostat
GBR-00826	Capacitor 1.5 Mfd. <u>Old</u> act. motor, Dir. of Rot. & 220-240/50 Volt. Red.
GBR-00837	Cold Water Thermostat
GBR-00856	Bin Thermostat 66" cap. tube (standard)
GBR-00897	Actuator Toggle Switch
GBR-00909	Water Plate Spring (2 req'd.)
GBR-00937	Cam Shaft Bracket (2 req'd.)
GBR-00942	Cam Shaft (All GB/GT550)
GBR-00949	Rear Cam
GBR-00959	Roll Pin (10)
GBR-00969	Front Cam
GBR-00972	Actuator Motor (GB1220 Upper) <u>Old</u> , See Actuator Motor application chart for replacement requirements.
GBR-01353	Air Cooled Condenser (GB420A/430A/440A/450A/GT330A/340A/350A)
GBR-01360	Fan Blade (GB420A/430A/440A/GB620A/630A/640A)
GBR-01362	Fan Support (GB421A/431A/441A)
GBR-01363	Fan Shroud (GB420A/430A/440A)

Parts List-Numerical

Part Number	Description
GBR-01364	Fan Motor, 115/60 (GB421A/431A/441A)
GBR-01375	Water Solenoid Valve, 120V coil (GB421/431/441/451/GT551)
GBR-01376-FF	Water Sol., 240V coil (GB4X4/4X7/6X4/6X7/12X4/12X5/12X8/GT554)
GBR-01379	Water Solenoid Valve Inlet Strainer
GBR-01385-01	Start Relay (GB624/627 Cope. RSL5)
GBR-01385-03	Run Capacitor (GB441/634/637/647)
GBR-01395-05	Run Capacitor (GB1224)
GBR-01498	Pump & Defrost Switch (GB1220/1240/1250 Lower)
GBR-01889	Refrigerant Inlet Fitting 3/8" (Remote condenser models)
GBR-01890	Refrigerant Discharge Fitting 1/2" (Remote condenser models)
GBR-02087	Hose Kit (All models)
GBR-02290	Check Valve (Remote cond. models & GB1220W/1240W/1250W)
GBR-02343	Receiver (GB1220W/1240W/1250W)
GBR-02351	Head Pressure Control Valve (Remote cond. models, R-502/R-404a)
GBR-02353-01	Start Relay (GB1224/1244)
GBR-02353-02	Start Cap. (GB441/1224)
GBR-02354	High Pressure Cutoff, Auto. reset, R-502 (GB420/620)
GBR-02359	Expansion Valve (GT550/All GB except 450)
GBR-02750	Drier, 3 cu. in. (All self-contained "A" & "W" models except GB1200W)
GBR-03110-01	Modified Rotor (GB1220 Upper) <u>Old</u> act. motor
GBR-03153	Actuator Motor <u>Old</u> , OBS., See actuator motor application chart.
GBR-03230	Adjusting Screw (GT330/340/350), Pump & Defrost Switch
GBR-03347	Air Cooled Condenser (GB620A)
GBR-03370	Pump Down Controller (Remote cond. models), Cap. tube connection.
Click Here	Water Pump, 115/60 (GT331/341/351)
Click Here	Water Pump 220-240/50 (GT337/347)
GTR-00221	Water Plate (GT330/340/350 "C")
GTR-00222	Water Plate (GT330/340/350 "HK" & "K")
GTR-00373-02	Start Capacitor (GB421 Cope. RSU5)
GTR-00705	Liquid Cooled Condenser (GB420W/620W)
GYR-00201	Water Tank (GT330/340/350)
GYR-00202	Water Deflector (GT330/340/350)
GYR-00219	Water Tank Outlet Screen (GT330/340/350)

Parts List-Numerical

Part Number	Description
GYR-00361	Water Solenoid Valve, 120V coil (GT331/341/351)
GYR-00362-FF	Water Solenoid Valve, 240V coil (GT334/337/344/347/354/357)
102 1007 01	Relay Socket, 2-pole (GB430R/440R/454R/620R/630R/640R/650R/1240/1250/GT550R)
102 1007 02	Relay Socket, 3-pole (GB1220/1240 before Sept., '96)
102 1008 01	Valve Body (GT330/340/350 & GB430R/440R/GT550R hot gas)
102 1010 01	Valve Body (all applications except GT330/340/350 & GB430R/440R/454R/1220/1240/1250 hot gas)
102 1010 02	Valve Body (GB1220/1240/1250 hot gas)
102 1011 01	Coil, 120V (GB421/431/441/451/GT331/341/351/551)
102 1012 01	Coil, 240V (GB427/434/437/444/447/454/457/620/630/640/650/1220/1240/1250/GT334/337/344/347/354/357/554)
102 1014 01	Fan Motor, 115/60 (GB451A/GT331A/341A/351A/551A)
102 1014 02	Fan Motor, 220-240/50 (GB457A/657A/GT337A/347A/357A)
102 1015 01	Fan Motor, 208-230/60 (GB454A/654A/GT334A/344A/354A/554A)
102 1016 02	Fan Blade (GT330A/340A/350A/551A/554A/GB457A/650A)
102 1016 03	Fan Blade (GB451A/454A)
102 1018 02	Air Cooled Condenser (GB630A/640A/650A/1250A)
102 1018 03	Air Cooled Condenser (GT550A)
102 1020 01	Liquid Cooled Condenser (GB430W/440W/450W/GT550W)
102 1020 02	Liquid Cooled Condenser (GB1220W/1240W/1250W)
102 1020 03	Liquid Cooled Condenser (GT330W/340W/350W)
102 1020 04	Marine Liquid Cooled Condenser (MGB650W)
102 1020 05	Marine Liquid Cooled Condenser (MGB450W/MGT550W)
102 1020 06	Marine Liquid Cooled Condenser (MGT3XXW)
102 1021 01	Liquid Cooled Condenser (GB630W/640W/650W)
102 1023 01	Receiver (GB420R/430R/440R/620R/630R/640R/650R/GT550R)
102 1023 02	Receiver (GB1220R/1240R/1250R)
102 1025 02	Evaporator (GT330/340/350 "C")
102 1025 03	Evaporator (GT330/340/350 "HK")
102 1025 04	Evaporator (GT330/340/350 "K")
102 1035 01	Contactors, 120V coil (GB421/431/441/451/GT331/341/351/551)
102 1036 01	Contactors, 240V coil, 1-pole (GB427/434/437/444/447/454/457/620/630/640/650/1224/1244/1254/GT334/337/344/347/354/357/554)
102 1036 02	Contactors, 240V coil, 2-pole (GB1225/1245/1255/1258)
102 1037 01	Relay-Plug in, 2-pole/120V coil (GB421R/431R/441R/GT551R)

Parts List-Numerical

Part Number	Description
102 1037 02	Relay-Plug in, 3-pole/240V coil (GB1220/1240 before Sept., '96)
102 1038 01	Relay-Plug in, 2-pole/240V coil (GB624R/634R/644R/654R/1240 after Aug., '96/1250/GT554R)
102 1044 01	Run Capacitor (GB421 Cope. RSU5/GB431 Brist. M51B/GB434/454/457/GT331/334/341/344/GT354/357/554)
102 1047 02	Start Relay (GB434/634 Brist. M51B)
102 1047 03	Start Relay (GB437/637/647GT337)
102 1047 04	Start Relay (GB431/441/1254/GT331/341)
102 1047 05	Start Relay (GB644)
102 1047 06	Start Relay (GB454/GT334/344/354)
102 1047 07	Start Relay (GB447/GT347)
102 1047 08	Start Relay (GB444)
102 1047 09	Start Relay (GB451/GT351/551)
102 1047 10	Start Relay (GT357)
102 1047 11	Start Relay (GB457)
102 1047 12	Start Relay (GB657)
102 1047 13	Start Relay (GB654)
102 1047 14	Start Relay (GT554)
102 1048 01	Start Relay (GB421 Cope. RSU5)
102 1052 02	Pump-down Controller, Direct Conn. (GB454R/650R/1250R/GT550R)
102 1053 01	ICE-OFF-WASH Switch
102 1055 01	High Press. Cutoff, Manual Reset, R-502/404a (Cap. tube connection), (GB430/440/450/630/640/650/1220/1240/1250/GT330/340/350/550)
102 1066 01	Receiver (GB420/430/440/450/620/630/640/650/GT330/340/350/550W)
102 1071 01	Drier, 8 cu. in. (GB440R/454R/640R/650R/GT550R, and All GB1220/1240/1250)
102 1100 01	Drain Pan Assembly (All GB)
102 1100 02	Drain Pan/Chute (GT330/340/350)
102 1100 03	Drain Pan/Chute (GT330/340/350 Multiplex)
102 1100 04	Drain Pan (GT550)
102 1100 05	Ice Chute (GT550)
Click Here	Water Pump, 230/60 (GB434/444/454/624/634/644/654/1220/1240/1250/GT554)
Click Here	Water Pump, 230/60 (GT334/344/354)
102 1142 01	Liquid Level Control, 230V (GB427/434/437/444/447/454/457/620/630/640/650/1220/1240/1250/GT334/337/344/347354/357/554)
102 1154 02	Water Distribution Tube Kit (GT330/340/350)

Parts List-Numerical

Part Number	Description
102 1166 02	Check Valve-Harvest Regulator (GB430R/440R/454R/630R/640R/650R/1224R/1240R/1250R/GT550R)
102 1180 02	Actuator Motor (GT300) Old, OBS., use 102 1238 kit (see appl. chart)
102 1188 02	Expansion Valve (GB450/GT330/340/350)
102 1190 01	High Temperature Shutoff Thermostat (OBSOLETE, see EB#96002)
102 1191 09	Compressor (GB644 Brist.), OBS., use 102 1242 14 kit
102 1191 10	Compressor (GB434 Brist.), OBS., use 102 1242 18 kit
102 1191 11	Compressor (GT334 Brist.), OBS., use 102 1242 12 kit
102 1191 13	Compressor (GB441 Brist.), OBS., use 102 1242 15 kit
102 1191 14	Compressor (GB447 Brist.), OBS., use 102 1242 17 kit
102 1191 15	Compressor (GB647 Brist.), OBS., use 102 1242 16 kit
102 1191 16	Compressor (GT341 Brist.), OBS., use 102 1242 11 kit
102 1191 17	Compressor (GB1244 Brist.), OBS., use 102 1242 09 kit
102 1191 18	Compressor (GB1245 Brist.), OBS., use 102 1242 10 kit
102 1191 19	Compressor (GT344 Brist.), OBS., use 102 1242 12 kit
102 1191 20	Compressor (GB444 Brist.), OBS., use 102 1242 18 kit
102 1191 21	Compressor (GT551 Tec.)
102 1191 22	Compressor (GB1254 Tec.)
102 1191 23	Compressor (GB1255 Tec.)
102 1191 24	Compressor (GT351 Tec.)
102 1191 25	Compressor (GT357 Tec.)
102 1191 26	Compressor (GB654 Tec.)
102 1191 27	Compressor (GB657 Tec.)
102 1191 28	Compressor (GB451 Tec.)
102 1191 29	Compressor (GB457 Tec.)
102 1191 30	Compressor (GB1258)
102 1191 31	Compressor (GB454 Tec.)
102 1191 32	Compressor (GT354 Tec.)
102 1191 33	Compressor (GT554 Tec.)
102 1194 01	Start Relay (GB427 Cope. RSU5)
102 1195 01	Start Capacitor (GB427 Cope. RSU5)
102 1195 02	Start Capacitor (GB627, Cope. RSL5 & GB454/457/GT354/357/554)
102 1195 03	Start Capacitor (GB431//447/GT331//341/347 Brist.)
102 1195 04	Start Capacitor (GB634/637/647 Brist.)
102 1195 05	Start Capacitor (GB444/644/1244 Brist.)
102 1195 06	Start Capacitor (GB434/GT334/344 Brist.)

Parts List-Numerical

Part Number	Description
102 1195 08	Start Capacitor (GT351/551/GB451 Tec.)
102 1195 09	Start Capacitor (GB1254/GB654 Tec.)
102 1195 10	Start Capacitor (GB657 Tec.)
102 1196 01	Start Cap. (GB437/GT337 Brist. M51B) & (GB624 Cope. RSL5)
102 1197 01	Run Capacitor (GB624, Cope. RSL5 & GB444/447/644/GT347 Brist.)
102 1197 02	Run Capacitor (GB627 Cope. RSL5 & GB654/657 Tec.)
102 1197 04	Run Capacitor (GB437/GT337 Brist. M51B & GB451/GT351/551 Tec.)
102 1197 05	Run Capacitor (GB1244 Brist.)
102 1197 06	Run Capacitor (GB1254 Tec.)
102 1198 01	Overload Protector (GB421 Cope. RSU5)
102 1198 02	Overload Protector (GT351 Tec.)
102 1198 03	Overload Protector (GT551 Tec.)
102 1198 04	Overload Protector (GT357 Tec.)
102 1198 05	Overload Protector (GB457 Tec.)
102 1198 06	Overload Protector (GB451 Tec.)
102 1198 07	Overload Protector (GB454/GT554 Tec.)
102 1199 01	Overload Protector (GB427 Cope. RSU5)
102 1200 01	Overload Protector (GB624 Cope. RSL5)
102 1201 01	Drain Assembly (All GB)
102 1201 02	Drain Assembly (GT330/340/350)
102 1202 01	Front Panel (GB420/430/440/450/620/630/640/650)
102 1202 02	Front Panel (GB1220/1240/1250)
102 1202 03	Front Panel (GT330/340/350)
102 1202 07	Front Panel (GT550)
102 1203 01	Left End Panel (GB420/430/440/450/620/630/640/650/GT330/340/350)
102 1203 02	Left End Panel (GB1220/1240/1250)
102 1203 03	Left End Panel (GT550A)
102 1203 04	Left End Panel (GT550W/R)
102 1204 01	Right End Panel (GB420/430/440/450/620/630/640/650/GT330/340/350)
102 1204 02	Right End Panel (GB1220/1240/1250)
102 1204 03	Right End Panel (GT550A)
102 1204 04	Right End Panel (GT550W/R)
102 1205 01	Top Panel (All GB)
102 1205 02	Top Panel (GT330/GT340/350)
102 1205 03	Top Panel (GT550)
102 1206 01	Liquid Level Control, 115V (GB421/431/441/451/GT331/341/351/551)

Parts List-Numerical

Part Number	Description
102 1207 01	Stacking Kit (All GB)
102 1207 03	Stacking Kit (GT330/340/350 on GT330/340/350 or GT330/340/350 CLASSIC on GT300 Electronic)
102 1207 04	Stacking Kit (GT400/500/600 Electronic on GT330/340/350 CLASSIC)
102 1209 01	Actuator Motor Shaft Extension (All CLASSIC GB & GT550)
102 1210 01	Front Cam Pin (5)
102 1211 01	Ice Deflector (All GB)
102 1212 01	Fan Motor, 208-240/50-60, Retrofit Kit (see E.B. #02001) (GB427A/434A/437A/444A/447A/620A/630A/640A)
102 1213 01	Fan Support (GB427A/434A/437A/444A/447A)
102 1214 01	Fan Support (GB620A/630A/640A)
102 1214 02	Fan Support (GB450A/GT330A/340A/350A)
102 1214 03	Fan Support (GT550A)
102 1214 04	Fan Support (GB650A/1250A)
102 1215 01	Fan Shroud (GB624A/627A)
102 1215 02	Fan Shroud (GB630A/640A/650A)
102 1215 03	Fan Shroud (GT330A/340A/350A/GB450A)
102 1215 04	Fan Shroud (GT550A)
102 1216 01	Probes, Cap & Tube (All GB & GT550)
102 1216 02	Probes, Cap & Tube (GT330/340/350)
102 1217 01	Pump & Defrost Switch (all applications-see EB#96001)
102 1220 01	Harvest Regulator Valve, Remote Condenser models (GB430R/440R/454R/630R/640R/650R/1220R/1240R/1250R/GT550R)
102 1221 01	Cam Shaft (GT330/340/350)
102 1222 01	Cam Shaft Bracket-Front (GT330/340/350)
102 1223 01	Capacitor, 2 mfd. (GB434/444/624/634/644/1220/GT334 OLD actuator motor), 208-230/60 Voltage Reduction only.
102 1238 01	Actuator Motor Kit <u>New</u> , All 115/60 GT3XX CLASSIC models
102 1238 02	Actuator Motor Kit <u>New</u> , All 208-230/60 & 220-240/50 GT3XX CLASSIC models
102 1239 02	Timer, 230V (GB1220/1240/1250) <u>New</u> act. motor
102 1241 01	Capacitor 4 Mfd. <u>New</u> 115 Volt act. motor
102 1241 02	Capacitor 1 Mfd. <u>New</u> 230 Volt act. motor
102 1242 01	Compressor Retrofit Kit (GT331) OBS., use 102 1242 11
102 1242 02	Compressor Retrofit Kit (GB421/431) OBS., use 102 1242 15
102 1242 03	Compressor Retrofit Kit (GB624/634) OBS., use 102 1242 14
102 1242 04	Compressor Retrofit Kit (GB427/437) OBS., use 102 1242 17

Parts List-Numerical

Part Number	Description
102 1242 05	Compressor Retrofit Kit (GB627/637) OBS., use 102 1242 16
102 1242 06	Compressor Retrofit Kit (GB1224) OBS., use 102 1242 09
102 1242 07	Compressor Retrofit Kit (GT337) OBS., use 102 1242 13
102 1242 09	Compressor Retrofit Kit (GB1224/1244 1 Ph. Bristol to Tecumseh)
102 1242 10	Compressor Retrofit Kit (GB1225/1245 3 Ph. Bristol to Tecumseh)
102 1242 11	Compressor Retrofit Kit (GT331/341 Bristol to Tecumseh)
102 1242 12	Compressor Retrofit Kit (GT334/344 Bristol to Tecumseh)
102 1242 13	Compressor Retrofit Kit (GT337/347 Bristol to Tecumseh)
102 1242 14	Compressor Retrofit Kit (GB624 Cope./634/644 Bristol to Tecumseh)
102 1242 15	Compressor Retrofit Kit (GB421 Cope./431/441 Bristol to Tecumseh)
102 1242 16	Compressor Retrofit Kit (GB627 Cope./637/647 Bristol to Tecumseh)
102 1242 17	Compressor Retrofit Kit (GB427 Cope./437/447 Bristol to Tecumseh)
102 1242 18	Compressor Retrofit Kit (GB434/444 Bristol to Tecumseh)
102 1247 01	Act. Motor Synchronization Kit (GB1220W/1240W before Sept., '96)
102 1247 02	Act. Motor Synchronization Kit (GB1220R/1240R before Sept., '96)
102 1252 01	Act. Switch Retro. kit (GB1220 w/102 1247 kit/GB1240 before Sept., 96)
102 1253 01	Crankcase Heater, 240V (GB454R/650R/GT554R)
102 1254 01	Ice Chute, GB Stainless Steel
102 1256 01	Manifold Kit, MGB 3-high
102 1262 01	Replacement Gasket, MGB-SK
102 1264 01	Expansion Valve, GBO12XCPI, R-22
102 1265 01	Panel Screws, #8-18 S.S. (Pkg. of 10)
102 1266 01	Liquid Line Solenoid Valve & Coil (GBO12XCPI)
102 1267 01	Suction Line Solenoid Valve & Coil (GBO12XCPI)
102 1268 01	Drain Tube (GT550)
102 1269 01	Bin Door Kit (B-650)
102 1270 01	Bin Door Kit (B-950)
102 1271 01	Cam Shaft (GB450/650/1250/GT550)
102 1272 01	Cam Shaft (GT350)
102 1273 01	Bin Cover, Right Side (GT on B-550)
102 1274 01	Condenser Fan Motor, 230/50-60/50W (GB1250A)
102 1275 01	Condenser Fan Blade, 11" Dia. (GB1250A)
102 1292 01	Actuator Motor Kit <u>New</u> , All 115/60 GB and GT550 CLASSIC models
102 1292 02	Actuator Motor Kit <u>New</u> , All 208-230/60 & 220-240/50 GB and GT550 CLASSIC models

Parts List-Numerical

Part Number	Description
GBR-00856	Crushed & Cube Side Bin Thermostat (T-250/T-251 T-261/T-264)
GBR-00894	Transformer (AKD-125-FF)
TTR-02698	Gearmotor (AKD)
TTR-02711	Upper Bearing Assembly (AKD)
TTR-02716	Auger (AKD)
TTR-02717	Plastic Upper Bearing (AKD)
TTR-05144	Push Button Switch (AKD)
102 1007 01	Relay Socket (T-250/T-251 T-261/T-264)
102 1037 01	Relay-Plug in (T-251/T-261)
102 1038 01	Relay-Plug in (T-250/T-264)
102 1133 02	Crusher Motor (T-250/T-251 T-261/T-264)
102 1148 02	Drive Pulley-24 Tooth (T-250/T-251)
102 1148 03	Driven Pulley-72 Tooth (T-250/T-251)
102 1150 02	Drive Belt (T-250/T-251)
102 1152 02	Bearing (2 req'd.) (T-250/T-251)
102 1197 04	Run Capacitor (AKD)
102 1202 04	Front Panel (T-250/T-251 T-261/T-264)
102 1202 05	Front Panel-Upper (AKD)
102 1202 06	Front Panel-Bottom (AKD)
102 1217 04	Selector Switch (T-250/T-251 T-261/T-264)
102 1217 03	Interlock Switch (T-250/T-251 T-261/T-264)
102 1221 02	Selector Shaft (T-250/T-251 T-261/T-264)
102 1221 03	Drive Shaft (T-250/T-251 T-261/T-264)
102 1225 01	Selector Knob (T-250/T-251 T-261/T-264)
102 1226 01	Switch Actuator Link (T-250/T-251 T-261/T-264)
102 1227 01	Hopper Cap (T-250/T-251 T-261/T-264)
102 1230 01	Comb (T-250/T-251 T-261/T-264)
102 1231 01	Selector Plate (T-250/T-251 T-261/T-264)
102 1243 01	Spout (AKD)
102 1244 01	Spout Closure (AKD)
102 1245 01	Bottom Bearing Assembly (AKD)
102 1246 01	Straight Spout (AKD)
102 1257 01	Drive Pulley-13 Tooth (T-261/T-264)
102 1258 01	Driven Pulley-36 Tooth (T-261/T-264)
102 1259 01	Drive Belt (T-261/T-264)

Parts List-Numerical

Part Number	Description
102 1260 01	Bearing (2-req'd.) (T-261/T-264)
102 1261 01	Cutter Wheel Assembly (T-250/T-251 T-261/T-264)

Date Code

CODE: SERIAL NO'S.			
<u>YEAR</u>			
1958-0H	1974-2D	1990-4K	2006-5F
1959-0J	1975-2E	1991-4A	2007-5G
1960-1K	1976-2F	1992-4B	2008-5H
1961-1A	1977-2G	1993-4C	2009-5J
1962-1B	1978-2H	1994-4D	2010-6K
1963-1C	1979-2J	1995-4E	2011-6A
1964-1D	1980-3K	1996-4F	2012-6B
1965-1E	1981-3A	1997-4G	2013-6C
1966-1F	1982-3B	1998-4H	2014-6D
1967-1G	1983-3C	1999-4J	2015-6E
1968-1H	1984-3D	2000-5K	2016-6F
1969-1J	1985-3E	2001-5A	2017-6G
1970-2K	1986-3F	2002-5B	2018-6H
1971-2A	1987-3G	2003-5C	2019-6J
1972-2B	1988-3H	2004-5D	2020-7K
1973-2C	1989-3J	2005-5E	2021-7A
<u>MONTH</u>			
JAN.-M	APR.-R	JULY-U	OCT.-X
FEB.-N	MAY-S	AUG.-V	NOV.-Y
MAR.-P	JUNE-T	SEPT.-W	DEC.-Z
<u>EXAMPLE:</u>			
1000X1JM	1969	JAN.	
1000X4KH	1998	SEPT.	

KOLD-DRAFT

101 Corporate Woods Parkway
Vernon Hills, IL 60061

USA

847-215-4500

800-726-8762

FAX: 847-541-1759

www.kold-draft.com

KOLD-DRAFT

an Ali Group Company



The Spirit of Excellence