

# TABLE OF CONTENTS

Introduction .....	1
Dispensing System (How it Works) .....	2
Table of Contents .....	3
Specifications and Dimensions .....	4
Specifications .....	5
Electrical Requirements .....	6
Installation — Selecting Location .....	7
Location .....	8
Installation Limitations .....	9
Uncrating — Set Up .....	10, 11
Inlet Water Supply and Drain .....	12
Final Check List .....	13
Installation — Start Up .....	14
Cabinet Chassis Rear View .....	15
Chassis — Water Cooled .....	16
Chassis — Air Cooled .....	17
Storage Bin Rotor .....	18
Lower Front Door — Front and Side Views .....	19
Lower Front Door — Rear and Side Views .....	20
Gear Rotor Drive .....	21
Bearing Housing Assy .....	22
Gear Motor — Drive .....	23, 24
Dispensing Cycle .....	25
Harvest Cycle .....	26
Freezing Cycle .....	27
Control Box — Water Cooled .....	28
Wiring Diagram — Water Cooled .....	29
Control Box Air Cooled .....	30
Wiring Diagram — Air Cooled .....	31
Service Analysis .....	32
Water Pump .....	33
Compressor 115/60/1 .....	33
Graphics Plates .....	34
Instructions: Coin Key Hookup .....	35, 36
Functional Parts and Maintenance .....	37, 38, 39
Cleaning Instructions .....	40, 41
Ice Machine .....	40
Bin Rotor Areas .....	41
Cuber Section .....	41

**THIS PAGE  
INTENTIONALLY  
LEFT BLANK**

**THIS PAGE  
INTENTIONALLY  
LEFT BLANK**

**THIS PAGE  
INTENTIONALLY  
LEFT BLANK**



## CD20 SERIES

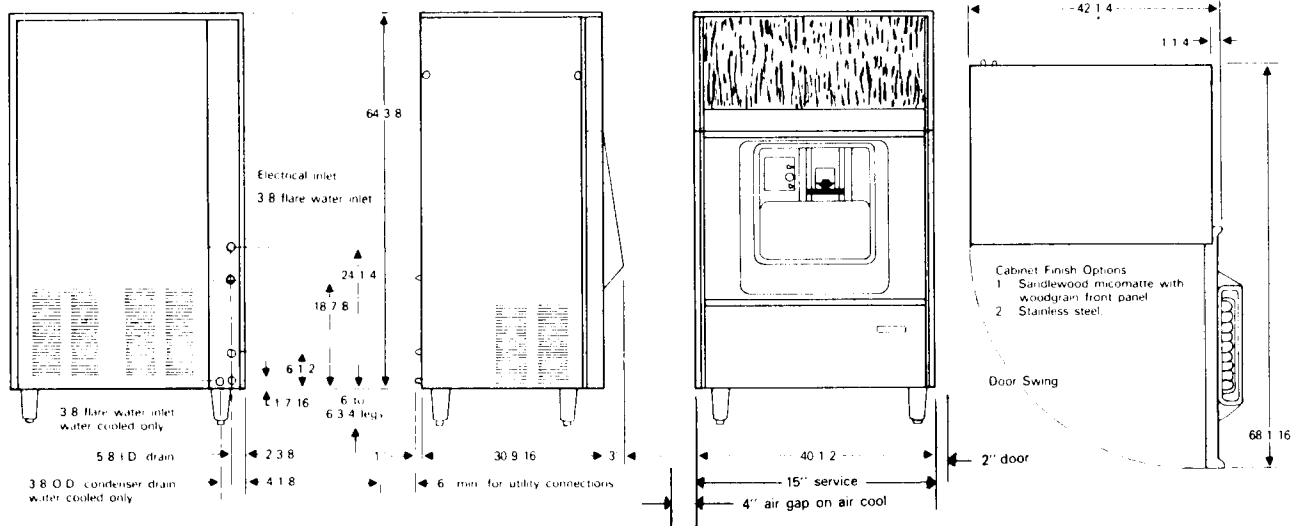

## SPECIFICATIONS:

Cubes	Model	Condensing Unit	Compressor Horsepower	Finish (P-Painted) (SS-Stainless steel)	Shipping Weight (lbs.)
Medium	CD20AE-1A	Air	3/4	P*	600
Medium	CD20AS-1A	Air	3/4	SS**	600
Medium	CD20WE-1A	Water	3/4	P*	600
Medium	CD20WS-1A	Water	3/4	SS**	600

\*Painted Models have sandlewood micomatte finish with woodgrain front panel.

\*\*Stainless Steel panels also available.

Basic Electricals	Minimum Wire Sizes (w-wire) (g-gauge)	Total Amperages
Air Cooled 115/60/1	2-W 10-g	17.0
Water Cooled 115/60/1	2-W 10-g	16.2

Specifications subject to change without notice.

## SPECIFICATIONS

Water Pressure .....	(Minimum 20 pounds) Maximum 70 pounds
Refrigerant Control .....	Twin Capillary Tube
Compressor 3/4 H.P.....	Copelaweld — 115/60/1
Condenser .....	Water or Air Cooled
Refrigerant .....	Refrigerant 12
Refrigerant Charge.....	Air — 27 ounces Water — 28 ounces
Power Consumption .....	17.0 Amperes-Total
Cubes per Harvest .....	120 medium sized cubes
Water Consumption to Produce Ice .....	3 Gal. per hour
Ice storage capacity at normal shut off —	150 pounds.

### DIMENSION

*Height — with 6" legs .....	71"
Height — less 6" legs .....	65"
Width .....	40-1/2"
Depth (includes sink protrusion) .....	33-3/4"

### WEIGHTS

Uncrated .....	570 lbs.
Crated .....	600 lbs.

\* Standard Models CD-20 do not include legs. Sales department carries leg package under accessory items.

## ELECTRICAL REQUIREMENTS

This unit requires 115 volts, 60 Hertz, 1 phase current.

Total operating draw is 17.0 AMPS.

Recommended wiring is 10 gauge wire with solid ground wire and a separate 30 AMP circuit.

An electrical junction box with three wire cord and 6" stubs is located inside the cabinet left rear corner. Remove left side panel for hook-up. Green wire is ground wire, balance of the unit is pre-wired, this is the only connection required.

<b>Component</b>	<b>Rating</b>	<b>Full Load AMPS.</b>
Refrigerant Compressor	3/4 H.P.	12.6
Condenser Fan Motor		.80
Bin Gear Motor Drive	1/5 H.P.	2.0
Water Pump		1.3
Spray Bar Drive Motor		.3
	<b>Total Amperage</b>	<b>17.0</b>

All external wiring should conform with National, State and local code requirements.

Maximum allowable voltage variation should not exceed +10% of the nameplate rating. Low voltage will cause erratic operation and may be responsible for serious damage to the overload switches and motor windings.

## INSTALLATION

### SELECTING LOCATION

Shipping weight with crate is 600 pounds.

For installation purposes, the CD20 will rest on 4 legs covering an area approximately 40 inches wide, 32 inches deep, therefore the floor area should be capable of supporting:

CD20 - Net Weight .....	570 pounds
CD20 - Ice Storage Capacity .....	150 pounds
Total Net Weight .....	720 pounds

#### Physical dimensions

*Height with 6" legs .....	71 inches
Depth including front sink protrusion .....	33.75 inches
Depth including Max Door Swing .....	68.06 inches
Width - Left to Right .....	40.50 inches

### INSTALLATION INSTRUCTIONS

The following installation instructions were written for use by a authorized tradesman only, not the user or customer. We suggest you call your local authorized Scotsman Service Agency for hook-up, start-up, and check out. He's listed under "Ice Making Machinery & Equipment" in your telephone book, yellow pages.

\* Standard Models CD-20 do not include legs. Sales department carries leg package under accessory items.



## LOCATION

All utilities, plumbing, electric and drain are provided on the back lower left support panel.

The entire left side panel is removable for service and maintenance. The machine must be positioned to provide a minimum clearance of 15" at the left side for service access (or provision must be made to pull the machine out of a restrictive alcove location).

Both the top walnut colored panel and the entire lower front section are hinged panels allowing access to the internal components. These panels are hinged on the right side, opening left to right. These two door panels, when open extend approximately one and three quarters inches beyond cabinet right side dimension.

In order to open these doors, provide 2" clearance on right side.

Since the refrigeration unit in some models is air cooled, a minimum 4" air gap must be maintained on left side and back to provide sufficient quantities of circulating air.

# INSTALLATION LIMITATIONS

## ELECTRICAL

1. Scotsman, like most manufacturers, purchases electrical motors that are rated to operate within 10% variance above or below nameplate ratings.

Improper voltages applied to Scotsman equipment can cause premature failures and burnouts. Failures of this type are not considered as factory fault or defect.

## AMBIENT

2. **WARNING** — This machine is not designed for outdoor installations. This machine will not operate when air temperatures are below 50° F. or above 100° F.

**NOTE:** This unit incorporates a "hot gas" defrost system.

Air cooled units require a minimum 50° fahrenheit ambient air, otherwise, the hot gas system will not defrost the formed ice cubes, resulting in a freeze up that will ruin the freezer section, necessitating a costly repair.

Water cooled models pose no problem since pressure can be regulated by adjustment to the water regulating valve.

This unit was not fabricated nor intended to be installed outdoors.

## WATER

3. Scotsman Ice Systems require 20 pounds flowing water pressure to operate satisfactorily. Pressures lower than 20 pounds or interruptions in the water supply can cause serious mechanical damage to this product.

This machine will not operate when water supply temperatures are below 40°F. or above 100° F.

# UNCRATING — SET-UP

ITEM NO.	PART NO.	DESCRIPTION
1.	A23368-001	Top Panel
2.	A2335-001	Back Panel
3.	A25997-001	Upper Door
4.	A26001-001	Lower Door
5.	A23349-001	Left Side Panel
6.	02-2094-01	Lock Plug
7.	03-1544-01	Hex Socket Screw
8.	A233349-001	Right Side Panel
9.	03-1512-02	Top Hinge Pin

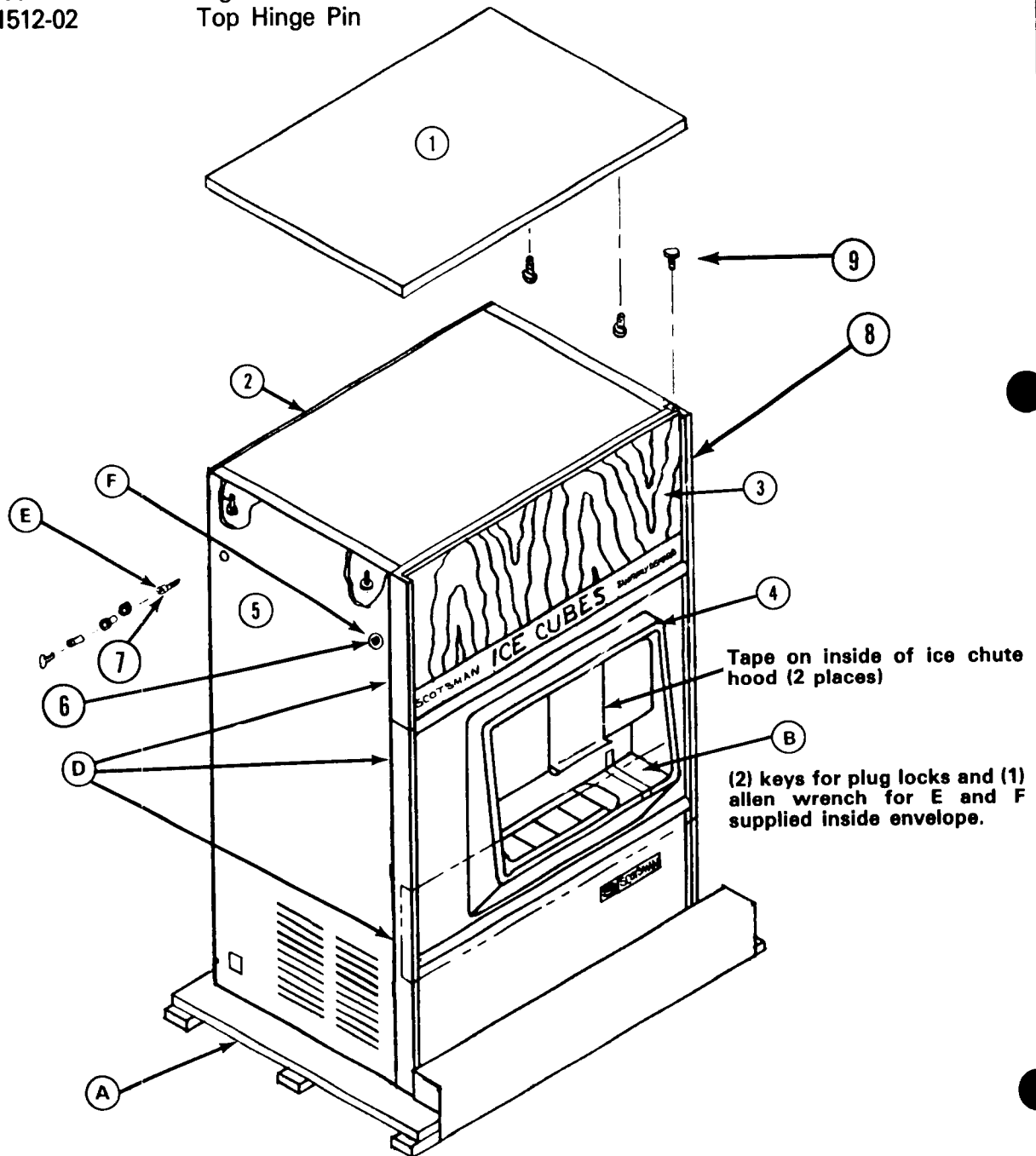

## UNCRATING — SET UP

The complete unit comes in one plywood crate, nailed together. Remove crating in normal manner, being careful not to scratch cabinetry with nails that protrude through crating.

Tip unit back far enough to remove four bolts holding crate bottom to unit base (A). Install legs in base and set unit upright.

Now remove envelope taped to front door grill, containing lock keys and allen wrench (b). Using key, remove the two locking tumblers from the top of the left side panel (E) (F). Now insert allen wrench thru key lock blank (E) and unscrew the socket head bolt holding panel. Next insert allen wrench into socket (F) and turn up or counter clockwise 1/2 turn. This releases a dual lock clutch that hold tight, also after releasing this lock, open top front door one inch to clear positioning pin from left side panel. Pull top side panel out far enough to clear top panel, then lift bottom of panel from two bottom positioning pins.

Remove all visible, external masking tape around panels, drain grill, etc. (2) fast-lead thumbscrews hold the lower panel securely to cabinet. Note: These fast-lead thumbscrews are found inside the left side panel area, facing the front of the cabinet.

After releasing 2 fasteners, pull doors open to expose inner front of machine. Remove masking tape from freezer curtains, splash guards, etc. Also from inside the back of the clear plastic delivery chute in front door.

Door panels can be closed and complete unit moved to final location for installation.

**NOTE:** Standard models CD-20 do not include legs. Sales department carries leg package under accessory items.

## INLET WATER SUPPLY

Only one supply line is required. A 3/8" SAE male flare fitting extends thru the left rear cabinet corner.

Two (2) 3/8" SAE male flare fittings are required for Water Cooled models. The second is for the condenser.

A minimum 3/8" copper supply line should be used. Connect to a cold water supply line with regular plumbing fittings with a shut off valve installed in an accessible place between supply line and machine.

**IMPORTANT:** Minimum 20# flowing water pressure is required.

When choosing the water supply for this cuber, consideration should be given to:

- A. Length of run
- B. Water clarity and purity.
- C. Adequate supply pressures

Since water is the most important single ingredient in producing ice, you cannot over emphasize the three items mentioned above. Low water pressure (below 20 pounds) may cause system malfunction. Water containing excessive minerals will tend to produce cloudy colored cubes and scale build up on parts in the water system.

Heavily chlorinated water can be controlled using charcoal or carbon filters.

In areas where water pressures exceed 70 pounds, install a pressure regulator, set at 40 pounds. NOTE: If a positive stop device such as a solenoid is in the same water line as cuber, install a water hammer arrestor.

**WARNING:** THIS MACHINE MUST NOT BE ALLOWED TO OPERATE WHEN THE WATER SUPPLY IS SHUT OFF, OR AT BELOW RECOMMENDED WATER PRESSURE. TURN MASTER SWITCH TO "OFF" POSITION WHEN WATER SUPPLY IS OFF, OR WHEN WATER PRESSURE IS BELOW RECOMMENDED OPERATING PRESSURE.

## DRAIN

This unit comes with all internal plumbing completed.

One 5/8" ID clear plastic tube carries all drain water out of cabinet at lower left rear corner. See page 4 .

Item 2 — Page 15 is an open drain pan which collects melted water from the ice storage bin and ice cubes or meltage from the serving area, drain grille.

For alcove installations, leave space to unhook drain for necessary service.

Use open, trapped or vented drains to avoid back-up, provide 1/4" fall per running foot of drain line.

## FINAL CHECK LIST

1. Is the unit level? (IMPORTANT)
2. Have all electrical and piping connections been made?
3. Has the voltage been tested and checked against the nameplate rating?
4. Have the compressor hold-down bolts been checked to insure the compressor is snug to its mounting pads?
5. Is the water supply valve open and the electric power properly hooked up?
6. All masking tape removed from doors, panels and inner freezer curtain?
7. Is the unit clean? Has storage bin been wiped clean with cold water cloth?
8. Check all refrigerant and conduit lines to guard against vibrations and possible failure.
9. Is there 4'' clearance behind unit for proper air circulation?
10. Is unit in a room where ambient temperatures are minimum 50° F. even in winter months?
11. Has water supply pressure been checked to insure at least a minimum pressure of 20 pounds?
12. Is there 15'' clearance on left side for service accessibility?

## INSTALLATION — START UP

1. Open top and bottom front doors to facilitate start up and check out.
2. Make sure water supply is turned on, then check timer finishing clock in main control box making sure the micro switch roller is resting down in offset slot in the cam (harvest position). If adjustment is necessary, turn timer knob clockwise into harvest position.
3. Inspect components in electrical control box, check for loose or frayed wire, then turn both manual switches to "on" position. All cubers have two manual on-off switches. One is for motor compressor only during cleaning operation, one is master switch for complete unit.
4. When both switches are thrown "on", water inlet solenoid will be energized allowing water to enter freezer cup section. This will "fill" icemaker for the freezing cycle. Check operation of spray bar drive motor. Spray bar motor should be running during harvest cycle.
5. Allow clock to carry unit through harvest cycle. This will be approximately two minutes. Dial pointer should be set on Number 2-1/2. After the compressor starts, turn the dial completely around and send it through another harvest cycle. Do this several times. This will completely flush out machine of any dust that may have accumulated in shipment.
6. After machine has been properly flushed, allow it to go into a freezing cycle. Check for possible water leaks, check water pump operation, should be running freely. Also note if jet tube operation is correct, and that none of the jets are plugged.
7. Time clock dial does not rotate at the start of a freeze cycle; it is started later by the cube size thermostat control located above the power on/off switches.
8. Freezing time will be approximately 20 to 30 minutes in a 70 degree ambient. (Longer if above, and shorter if below). Average complete cycle time is 25 to 35 minutes.
9. Watch first cube harvest and check to make sure that plastic curtain sections have not been damaged in shipment. Also that curtains do not swing back into freezer and catch on spray bar.
10. Check size of Cubes made: If too small, after a second cycle, adjust cube size control to lower or colder setting — until desired cube size is reached. Normal cube size is with a 1/4" depression in crown.
11. Check texture of cubes made: Partially cloudy cubes throughout suggest unit running short of water near end of freezing, or possibly an extremely bad water condition, which would indicate use of filtering or purifying equipment. Contact SCOTSMAN-Queen Products Division, Ice Machine Service Department, Albert Lea, Minnesota, for further details.

# CABINET CHASSIS

## Rear View

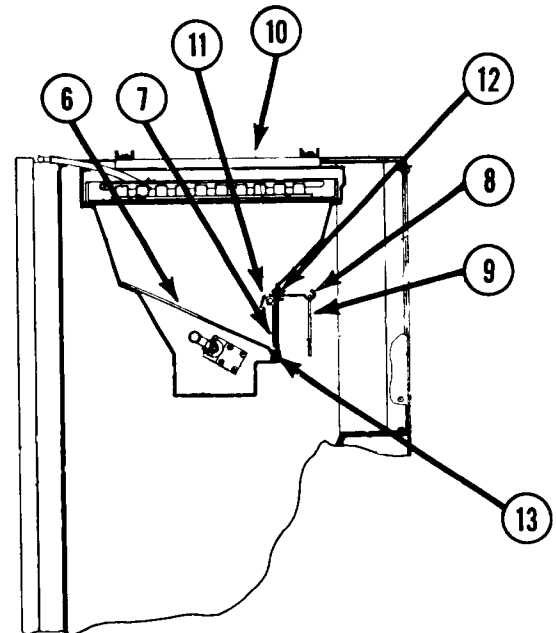
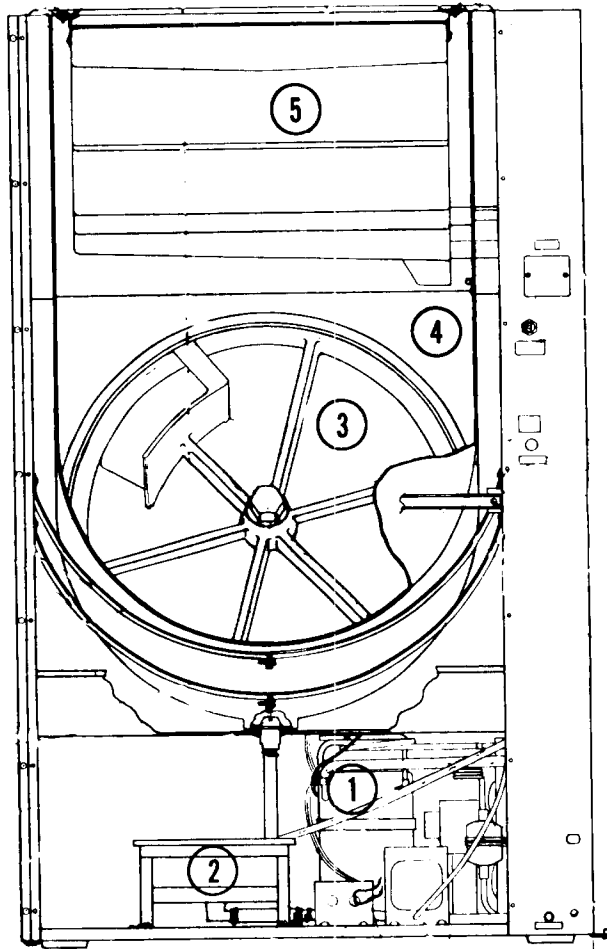

ITEM NO.	PART NO.	DESCRIPTION
1.	See Seperate P.L.	Compressor
2.	02-2309-02	Drip Pan
3.	A25368-001	Rotor Assy.
4.	11-0399-01	Bin Thermostat
5.	02-2309-01	Freezing Chamber
6.	02-1982-01	Cube Chute
7.	A24541-001	Curtain Assy.
8.	02-2136-01	Deflector Hanger
9.	02-2207-02	Cube Deflector
10.	A27274-001	Rubber Platen Assy.
	13-0638-00	Rubber Cup Holder (2)
11.	A24544-001	Hanger - Drip Lip
12.	A26661-001	Chamber Stiffener
13.	02-2137-01	Chip - Chute (2)



# CHASSIS Water Cooled

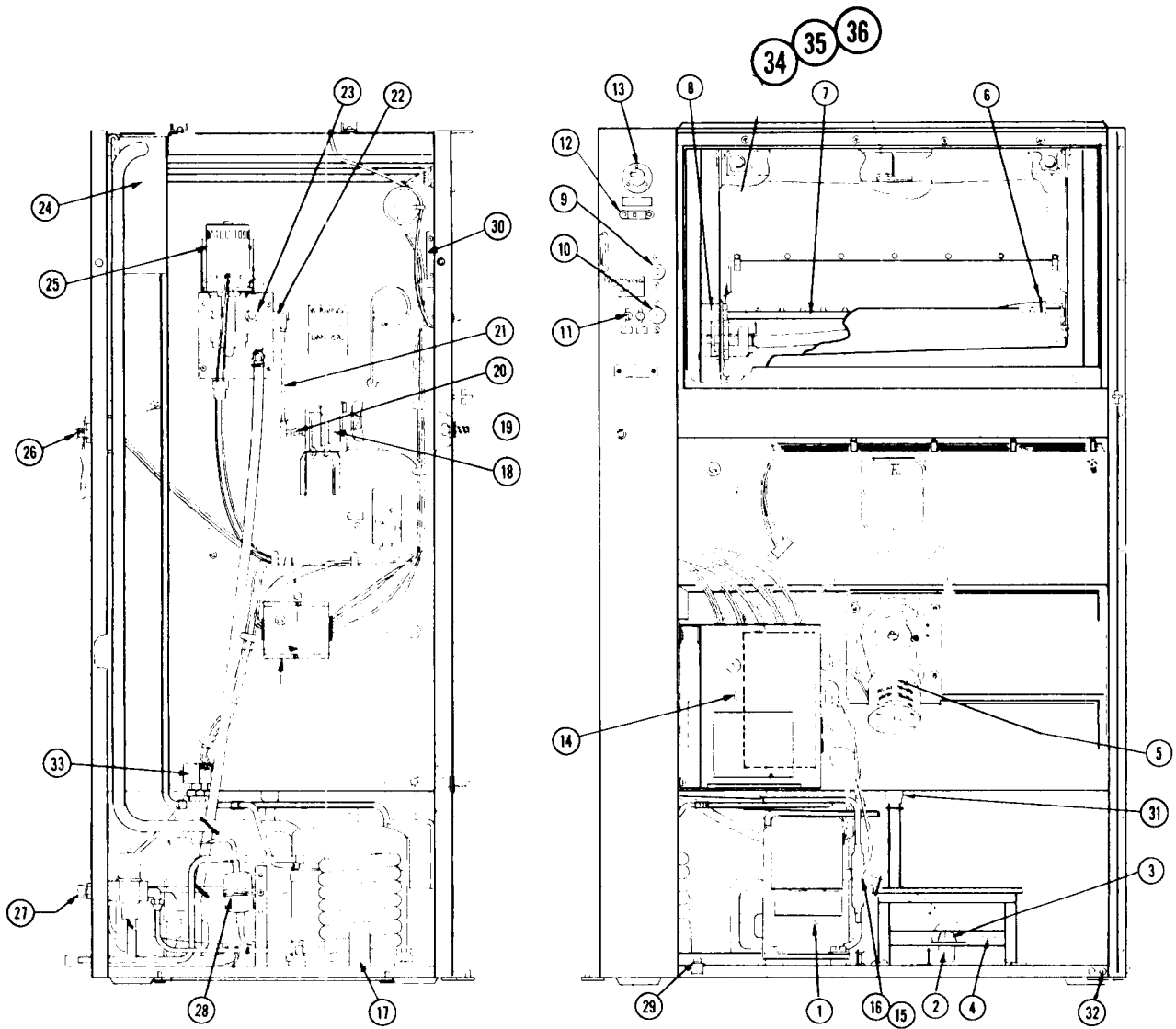

ITEM NO.	PART NO.	DESCRIPTION
1.	See Separate P.L.	Compressor
2.	02-1742-00	Drain Bottom
3.	02-1741-00	Drain Strainer Nut
4.	02-2309-02	Drain Pan
5.	See Separate P.L.	Gear Motor
6.	A16963-000	End Bearing
7.	A27288-001	Spray Bar
8.	A24512-001	Drive Bearing Support
9.	11-0399-01	Bin Thermostat
10.	11-0345-01	Cube Size Control
11.	12-0426-01	Toggle Switches (2)
12.	12-2054-01	Switch
13.	12-1993-01	Elapse Time Indicator
14.	See Separate P.L.	Control Box Assy.
15.	16-0560-00	Valve Core
16.	16-0563-00	Brass Cap
17.	18-3305-02	Water Cooled Condenser

ITEM NO.	PART NO.	DESCRIPTION
18.	A24743-001	Agitator Motor
19.	03-1541-02	Wing Screw
20.	A23694-001	Linkage Arm
21.	A23163-002	Linkage Rod
22.	A23884-001	Linkage Arm Spray Bar
23.	A27286-001	Drive Journal
24.	A26193-001	Suction Accum. Assy.
25.	See Separate P.L.	Water Pump
26.	12-1434-01	Inlet Water Solenoid
27.	11-0198-02	Water Regulating Valve
28.	02-0544-01	Refrigerant Drier
29.	A25549-001	Door Support
30.	02-2092-01	Dual Lock
31.	A24584-001	Bin Drain
32.	A25959-001	Bracket—Door
33.	12-2023-03	Hot Gas Valve
34.	03-1408-34	Washer
35.	03-1539-11	Retaining Ring
36.	03-1580-01	Pin

# CHASSIS

# Air Cooled

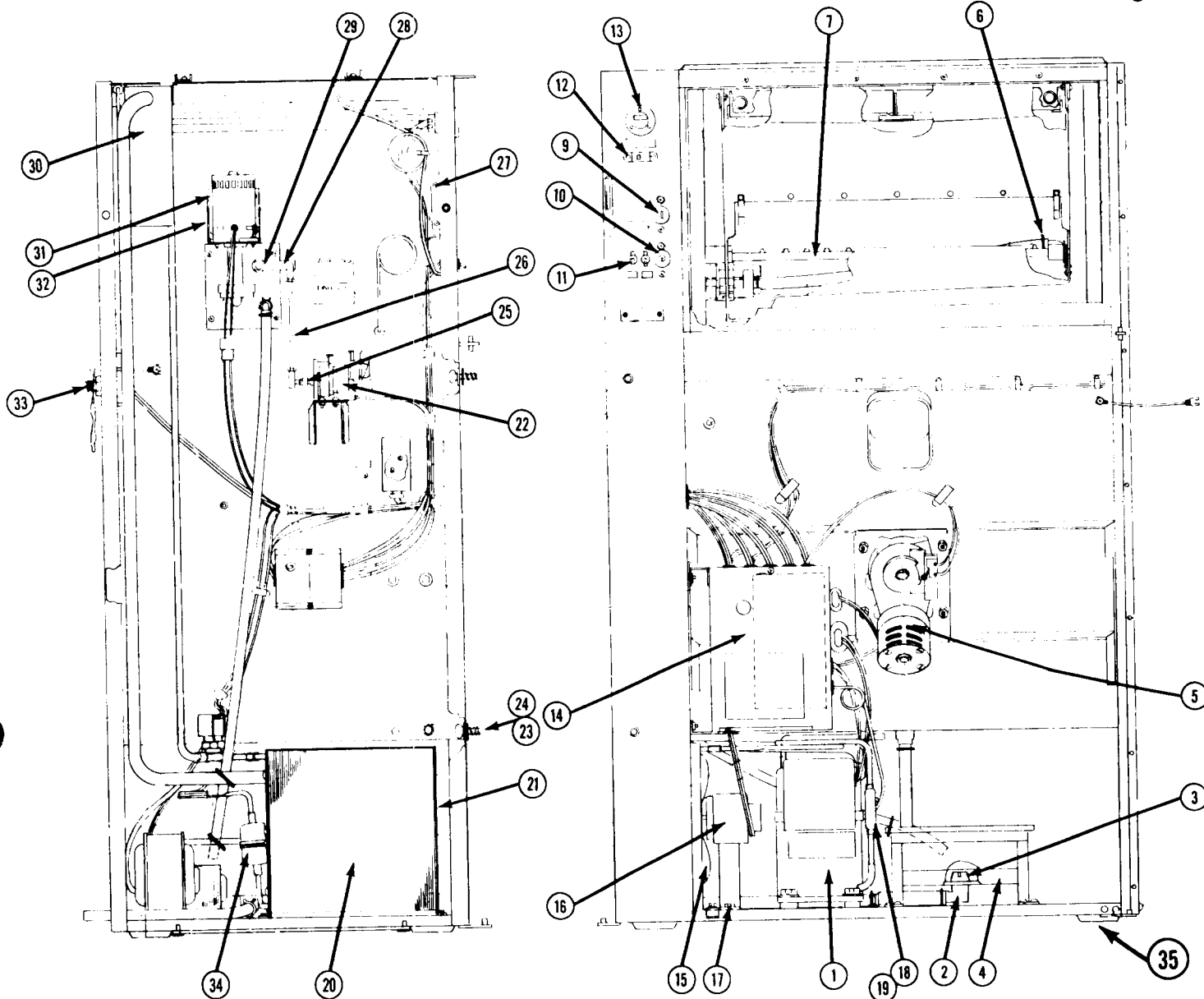

ITEM NO.	PART NO.	DESCRIPTION	ITEM NO.	PART NO.	DESCRIPTION
1.	See Separate P.L.	Compressor	18.	16-0560-00	Core - Service Port
2.	02-1742-00	Drain Bottom	19.	16-0563-00	Cap - Service Port
3.	02-1741-00	Drain Strainer Nut	20.	18-3703-01	Air Cooled Condenser
4.	02-2309-02	Drain Pan	21.	A23825-001	Shroud
5.	See Separate P.L.	Gear Motor	22.	A24743-001	Agitator Motor
6.	A16963-000	End Bearing	23.	03-1541-02	Wing Screw
7.	A27288-001	Spray Bar	24.	03-1543-01	Retaining Washer
8.	A24512-001	Drive Bearing Support	25.	A23694-001	Linkage Arm
9.	11-0399-01	Bin Thermostat	26.	A23163-002	Linkage Rod
10.	11-0345-01	Cube Size Control	27.	02-2092-01	Dual Lock
11.	12-0426-01	Toggle Switch	28.	A23884-001	Linkage Arm Spray Bar
12.	12-2054-01	Switch	29.	A27286-001	Drive Journal
13.	12-1993-01	Elapse Time Indicator	30.	A26193-001	Suction - Accum. Assy.
14.	See Separate P.L.	Control Box	31.	See Separaty P.L.	Water Pump
15.	18-0625-00	Fan Blade	32.	A26218-001	Pump Bracket
16.	12-1681-01	Fan Motor	33.	12-1434-01	Inlet Water solenoid
17.	A25548-001	Fan Motor Mount	34.	02-0544-01	Refrigerant Drier
			35.	A25959-001	Door Hinge

## STORAGE BIN ROTOR

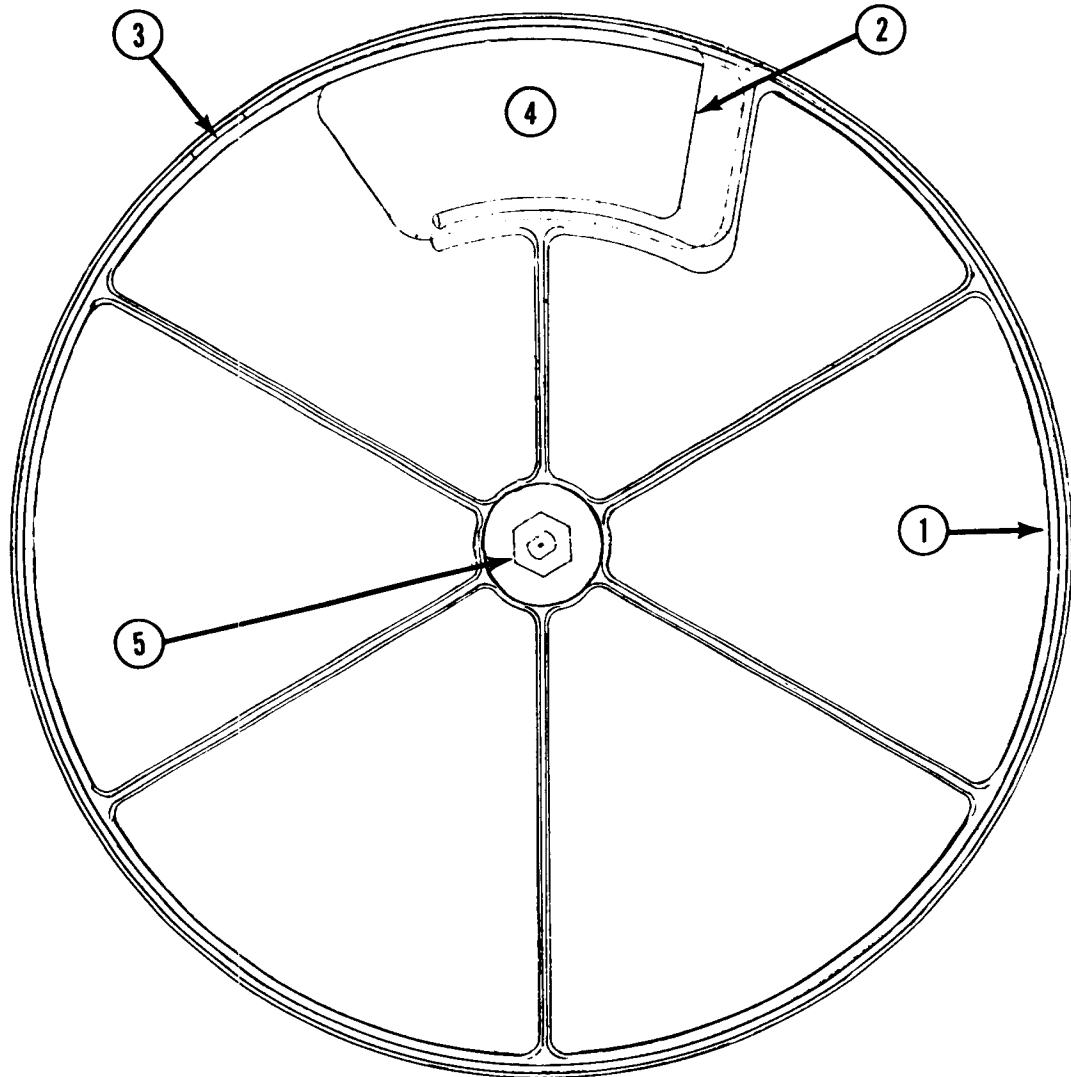

ITEM NO.	PART NO.	DESCRIPTION
1.	A25368-001	Rotor Assembly (Drum)
2.		Scoop Retainer
3.		Pick Up Shoe
4.		Ice Scoop
5.		Center Hub

**4 Ice Scoop** — The at rest drum position, inside storage bin, would have scoop in the 2:00 o'clock position, viewing machine from the front. As a vend is requested, the gear motor drive starts turning the drum clockwise through ice cubes in storage area. Scoop fills with ice and as it passes ice delivery opening at 12:00 o'clock, cubes fall by gravity into delivery chute. Drum continues thru to 2:00 o'clock, closing ice opening and stopping.

## LOWER FRONT DOOR

### Front & Side Views

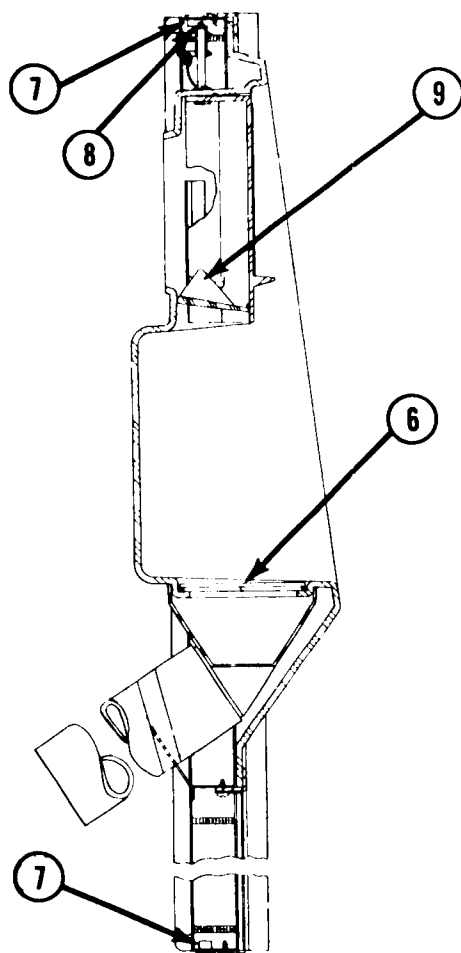

A. Clear plastic delivery chute. Fills with cubes during a vend. Customer pulls down, bottom of chute opens, dropping cubes into ice bucket. Chute is spring loaded and at its uppermost position, engages a safety micro switch in back of panel. This switch when open or disengaged, will not permit a dispensing operation. Chute must be entirely closed (uppermost position) before dispensing section will operate.

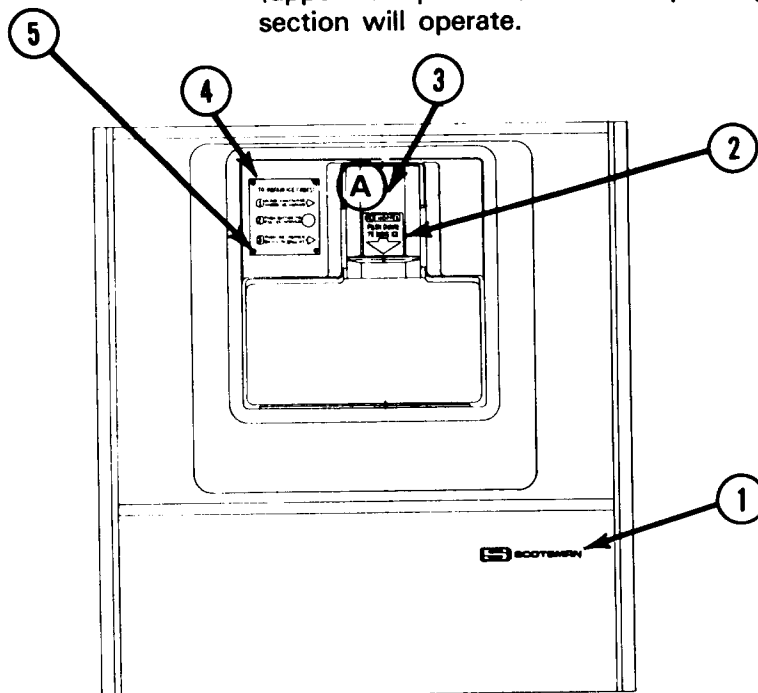

ITEM NO.	PART NO.	DESCRIPTION
1.	15-0156-00	Emblem
2.	15-0583-01	Decal — Ice Chute
3.	02-1994-01	Hood For Ice Chute
4.	See Separate P.L.	Instruction Plate
5.	03-1581-01	Screw 4/Unit
6.	02-1998-01	Grille
7.	02-2012-01	Bushings 2/Door
8.	03-1539-03	Retainer Ring
9.	02-1995-01	Ice Chute

## LOWER FRONT DOOR Rear & Side Views

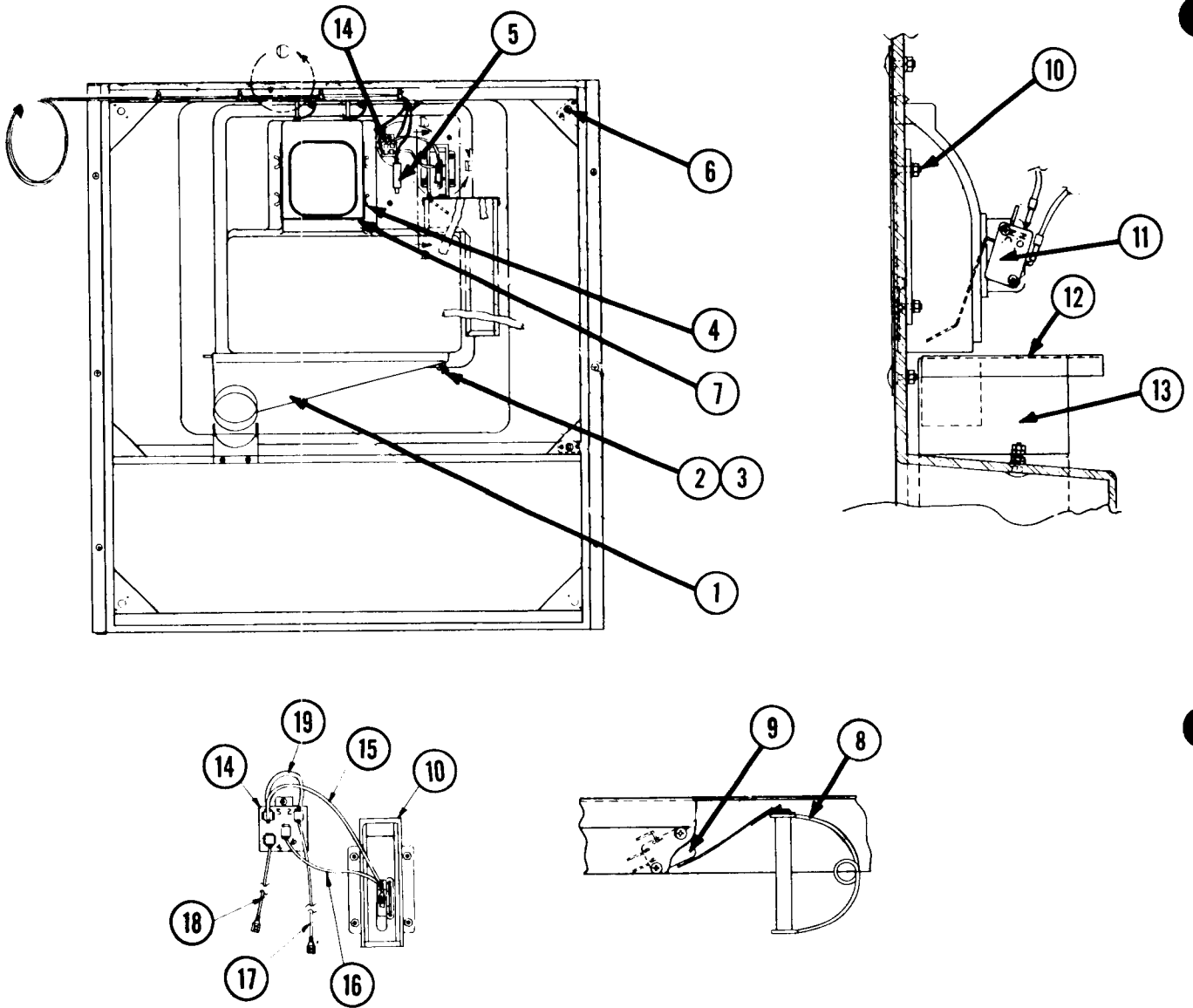

ITEM NO.	PART NO.	DESCRIPTION
1.	A24523-001	Drain Tray Ass'y.
2.	03-0255-02	Wing Nuts
3.	A24655-001	Spacers
4.	03-1279-01	Thumb
5.	12-1878-01	Push Button Switch
6.	03-1542-01	Retainer Nut
7.	A25377-001	Shield
8.	02-2097-01	Torsion Spring
9.	A25545-001	Safety Switch
10.	A27101-001	Body Coin Mech.
11.	12-2046-01	Switch Lever
12.	A26838-001	Coin Box Cover
13.	A26826-001	Coin Box Assy.
14.	12-1873-01	Relay
15.		Red Wire
16.		Orange Wire
17.		Yellow Wire
19.		Orange Wire

# GEAR ROTOR DRIVE

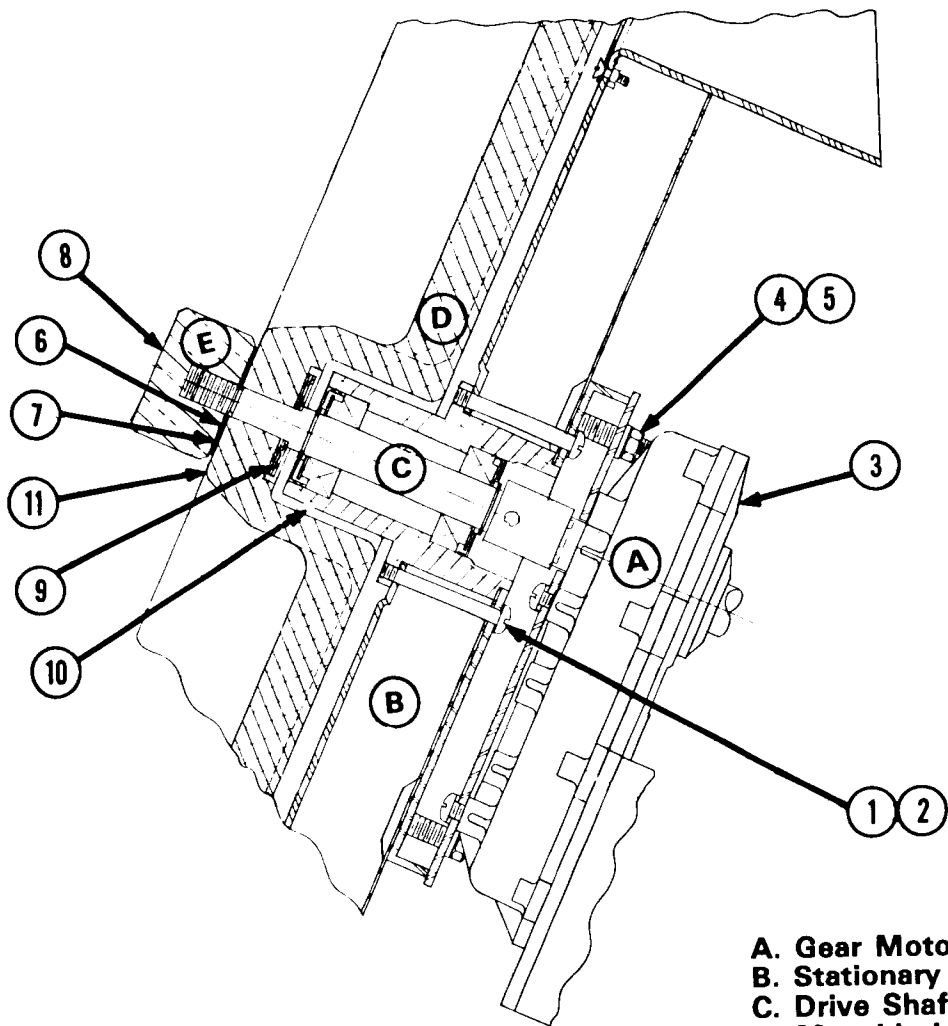

- A. Gear Motor Drive
- B. Stationary Front Panel
- C. Drive Shaft
- D. Movable Ice Rotor
- E. rotor Lock Nut

ITEM NO.	PART NO.	DESCRIPTION
1.	03-1403-72	Screws 6/Unit
2.	03-1417-08	Lockwasher 6/Unit
3.	See Separate P.L.	Gear Motor
4.	03-1410-05	Lockwasher
5.	03-1406-12	Nuts
6.	03-1408-26	Special Washer
7.	03-1409-16	Non-Metalic Washer
8.	A23408-001	Cap Nut
9.	A23685-001	Support Washer
10.	A26108-001	Bearing Housing Assy.
11.	A25363-001	Bin Rotor

# BEARING HOUSING ASSY.

## A26108-001

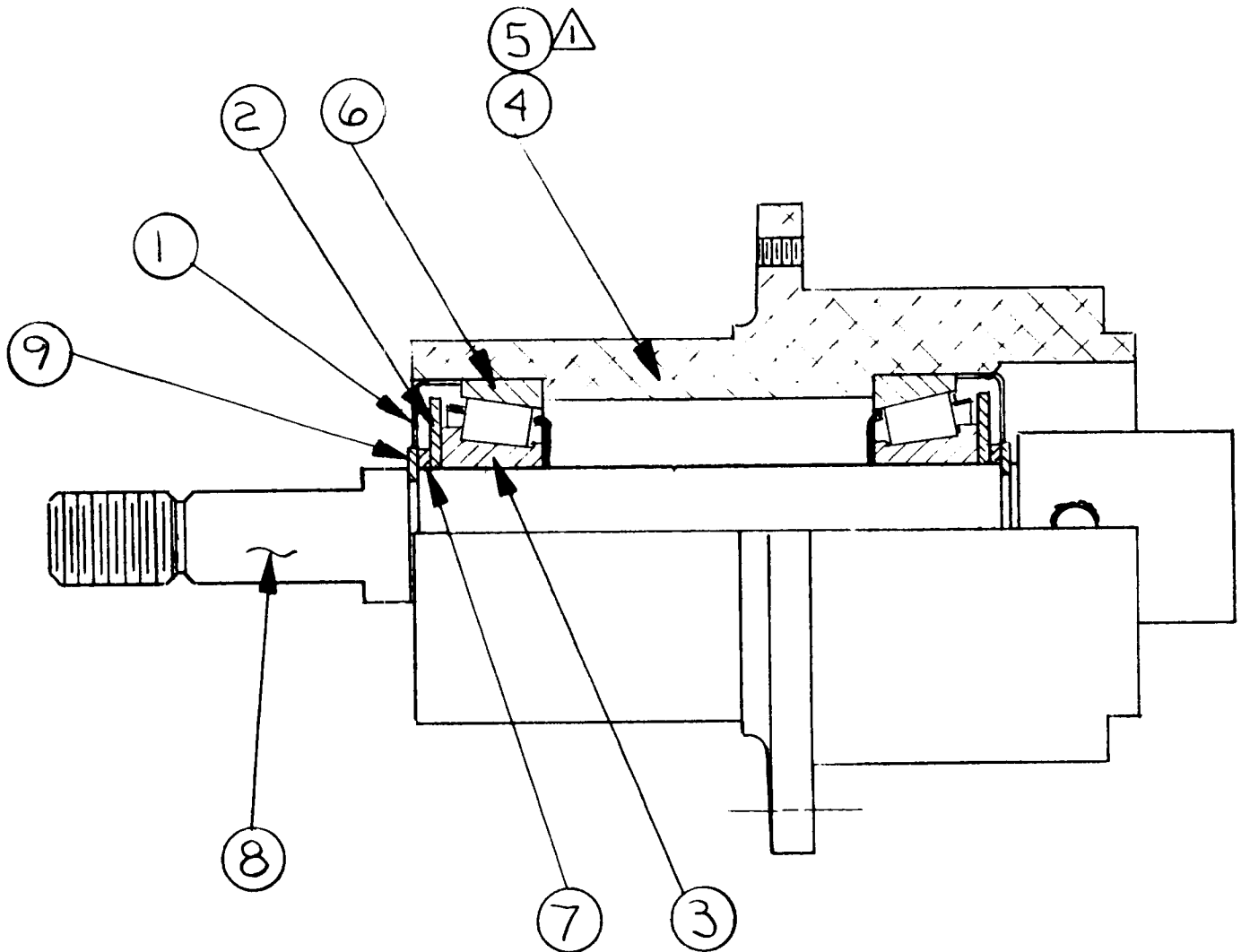

ITEM NO.	PART NO.	DESCRIPTION
1.	02-2026-01	Cup Closure
2.	02-2027-01	Flinger
3.	02-2186-02	Cone
4.	A26108-001	Bearing Housing Complete
5.	19-0309-01	Grease
6.	02-2186-01	Cup
7.	03-1408-27	Washer
8.	A26105-001	Bin Shaft Assy.
9.	03-1516-01	Retaining Ring

# A26398-021

## GEAR MOTOR — DRIVE

### 115/60/1

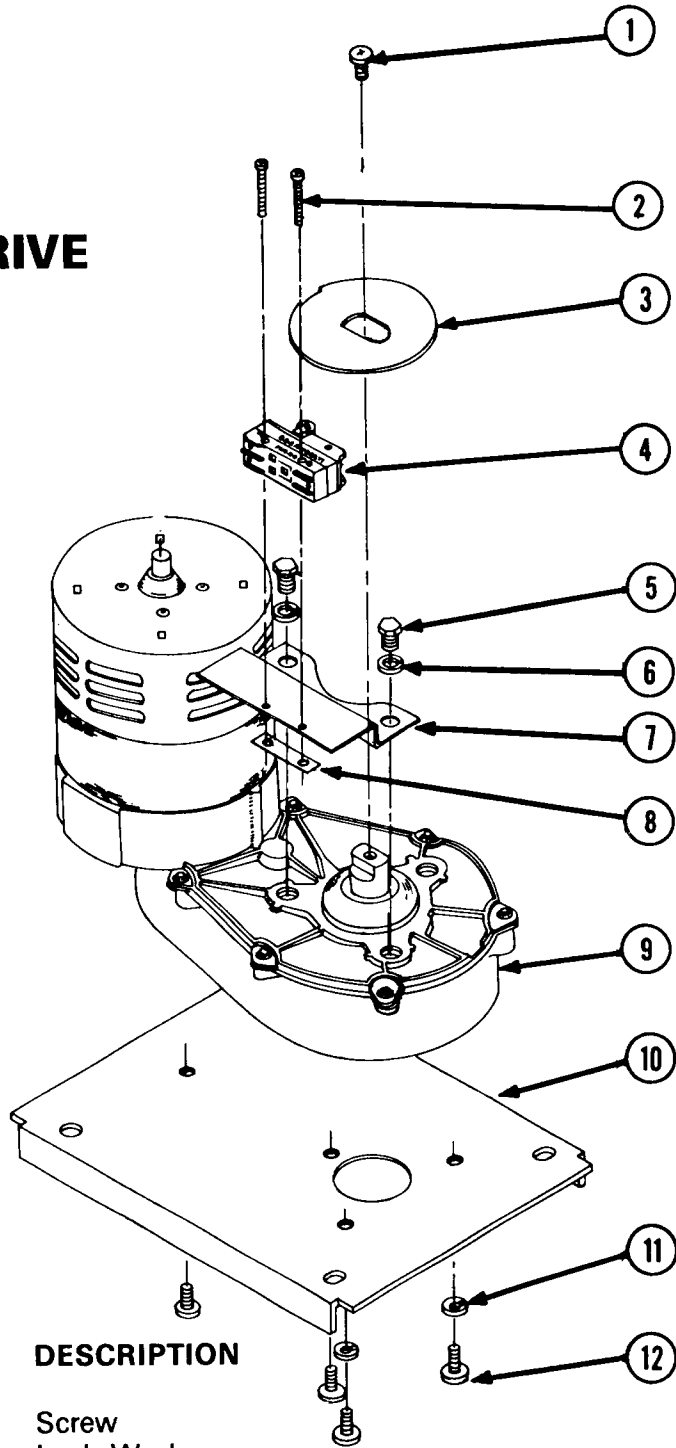

\*Items 2,4,5,6,7 & 8  
are not included  
with Gear Motor Assy.  
A26398-021

ITEM NO.	PART NO.	DESCRIPTION
1.	03-1405-03	Screw
1.	03-1410-03	Lock Washer
2.	03-1403-09	Screw
3.	A26686-001	Cam
4.	12-0876-00	Cam Switch
5.	03-1405-15	Screws
6.	03-1410-04	Lock Washer
7.	A24459-001	Bracket Cam Switch
8.	03-0886-00	Twin Speed Nut
9.	See Separate P.L.	Gear Motor (Less Switch Assy.)
10.	A23336-001	Motor Mount
11.	03-1410-03	Lock Washer
12.	03-1405-03	Screw



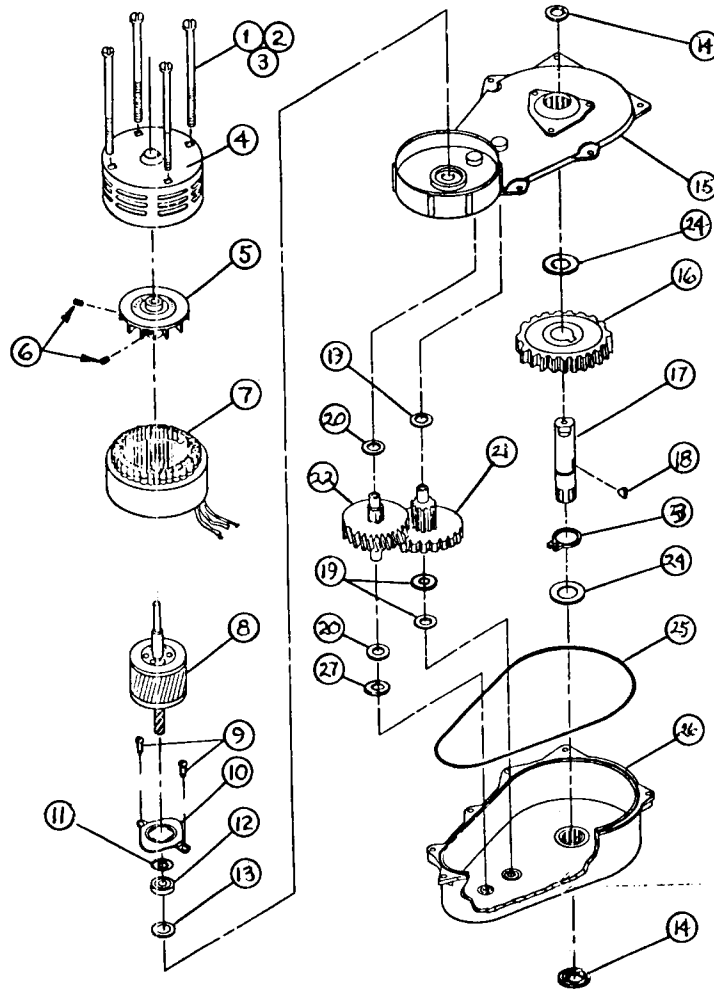

## Gear Motor Parts Breakdown

ITEM NO.	PART NO.	DESCRIPTION
1.	03-1403-74	Screw (4)
2.	03-1417-04	Star Washer (1)
3.	03-1410-02	Lockwasher (3)
4.	A17047-000	Housing w/bearing
5.	A16915-000	Cooling Fan
6.	03-1246-00	Set Screws (2)
7.	12-2036-01	Stator
8.	A19884-003	Rotor w/bearing & retainer
9.	03-1245-00	Sem Screw (2)
10.	A19871-000	Bearing Retainer
11.	03-1408-08	Washer
12.	02-1501-00	Bearing Only
13.	02-1504-00	Oil Seal-Input Shaft
14.	02-1503-00	Oil Seal - Output Shaft
15.	A16920-021	Gear Case Top w/bearings & seals
16.	02-2098-01	Output gear
17.	02-2311-01	Output Shaft
18.	03-1475-01	Key
19.	03-1408-06	Washer (3)
20.	03-1408-19	Washer (2)
21.	02-1510-00	2nd Gear & 3rd Pinion
22.	02-1511-00	1st Gear & 2nd Pinion
23.	03-1515-03	Snap Ring
24.	03-1408-21	Washer (2)
25.	02-1505-00	'O' Ring
26.	A23418-001	Gear Case Bottom w/bearings & seals
27.	03-1408-20	Washer

## DISPENSING CYCLE

### Gear Motor Drive — Control

Dispense cycle cam is attached to outboard end of gear motor shaft, turning clockwise at 6 revolutions per minute during the dispensing cycle. Inboard end of gear motor shaft is driving the dispensing bin rotor, on the inside of ice storage bin at the same time. The cam indent makes at one full revolution, stopping when micro switch roller drops in slot.

Micro Switch No. 12-0876-00. Starts - Stops after one full revolution.

A26398-021 Gear Motor — 1/5 HP motor-thermal reset. 6 RPM clockwise rotation on output shaft.

The operation of the dispensing circuit consists of a push button switch which when pushed energizes the coil of the 24 V. dispensing relay. This closes the contacts to furnish 115 VAC to the gear motor.

The motor turns the rotor and cam which lifts the arm of the cam switch to shut the leads to the dispensing switch. So the dispensing switch can be released and the machine will continue through the dispensing cycle until the cam switch travels down in the slot of the cam to open the shunting circuits.

The spout switch is connected in series with the 24 V. power to the relay coil. Should the spout be opened, power to the relay circuit is interrupted and the dispensing will stop.

## HARVEST CYCLE

When the finishing timer reaches the last 3 minutes of its cycle, the machine defrosts with hot gas from the compressor. Electrically, the components in circuit are the compressor, fan motor, water pump, pressure control and both the water and hot gas solenoids.

The water flows from the solenoid valve, through the top of the freezing chamber, into the reservoir. The level in the reservoir is controlled by a stand pipe which directs the excess water to drain. This overflow "washes" the mineral concentration out of the reservoir area.

The refrigerant is now following the path of least resistance. The capillary tube restricts the normal route enough to force hot, uncondensed gas from the compressor to flow through the hot gas solenoid valve. From there it passes directly into the evaporator inlet, through the coils and down the suction line to the compressor.

The cubes, which are released by the hot gas, drop onto the inclined chute and into the bin. After the two minute defrost, the finishing timer switches the electrical circuit back through the cube size control and a new freezing cycle begins.

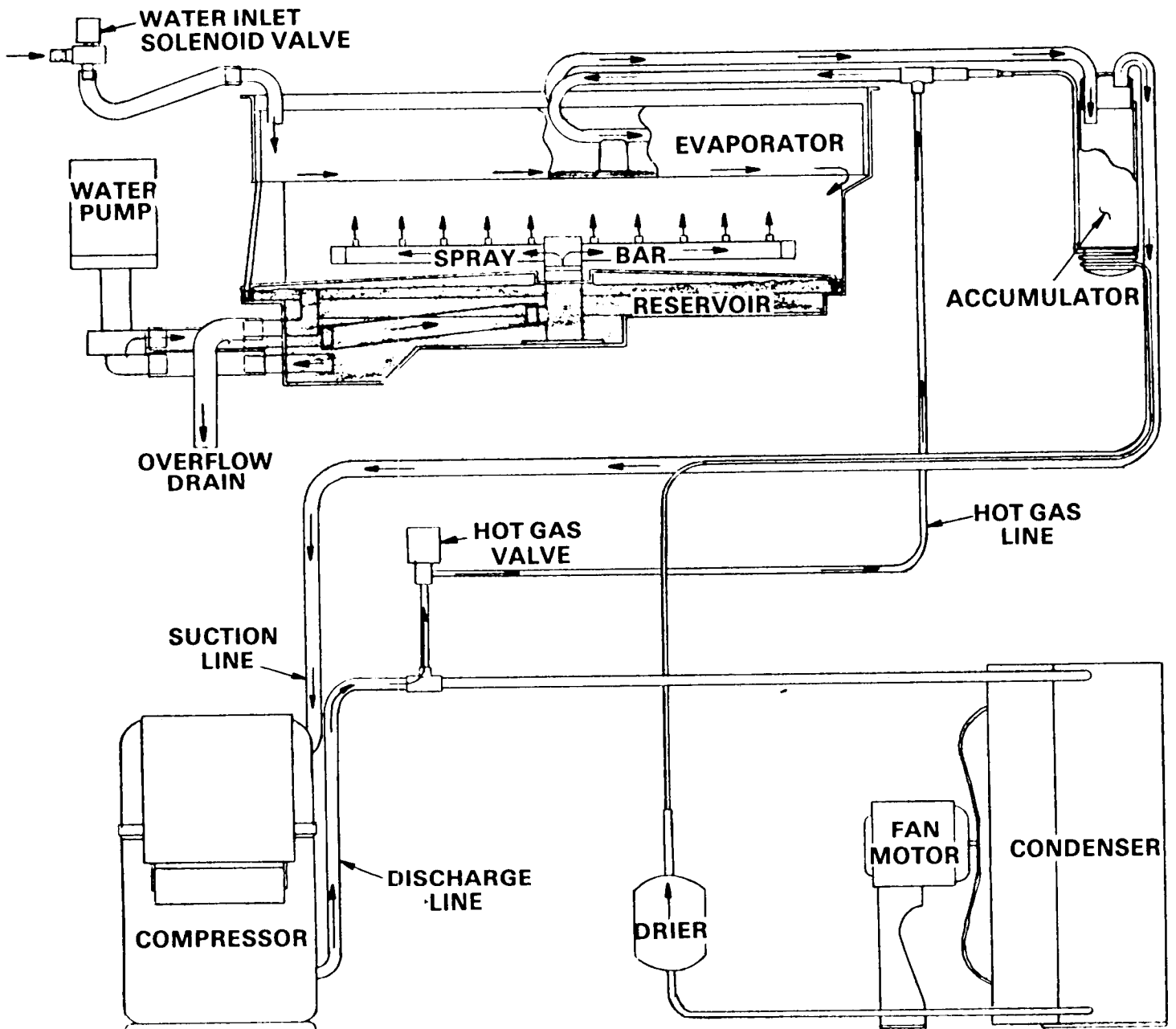

# FREEZING CYCLE

As the freezing cycle starts, the electrical circuit is completed to the compressor, fan motor, recirculating water pump and sprayer tube.

The refrigerant is moving from the compressor into the condenser. Then it passes through the capillary tube to the evaporator. From there, it goes back to the compressor to complete a normal refrigeration circuit. Both the water and the hot gas solenoid are closed.

When the ice cubes are about 3/4 formed, the cube size thermostat switches the electrical circuit to the finishing timer. This timer has a 15 minute cycle of which 12 minutes are used to complete the cubes and the last 3 minutes for defrost.

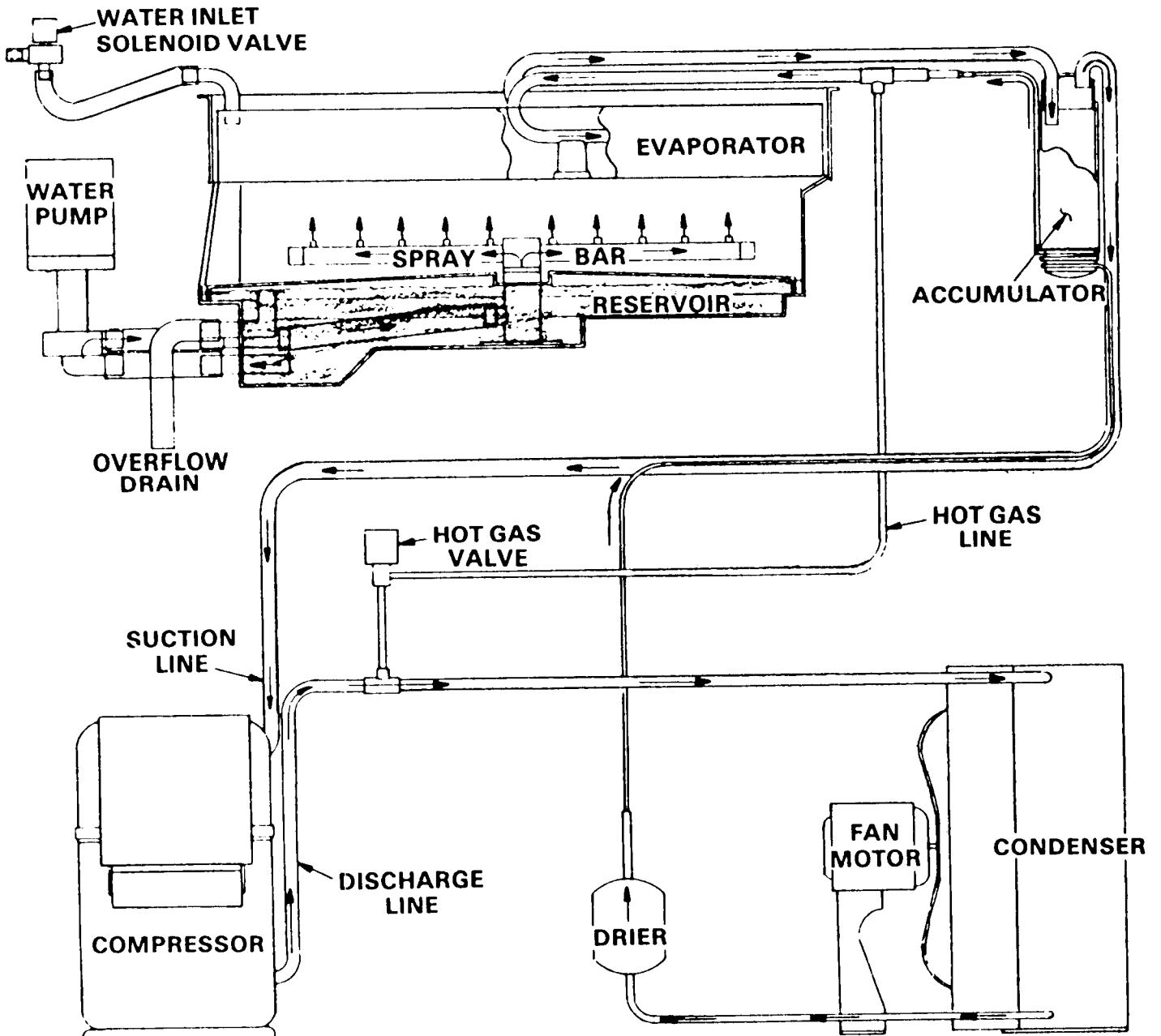

# CONTROL BOX ASSY.

## Water Cooled

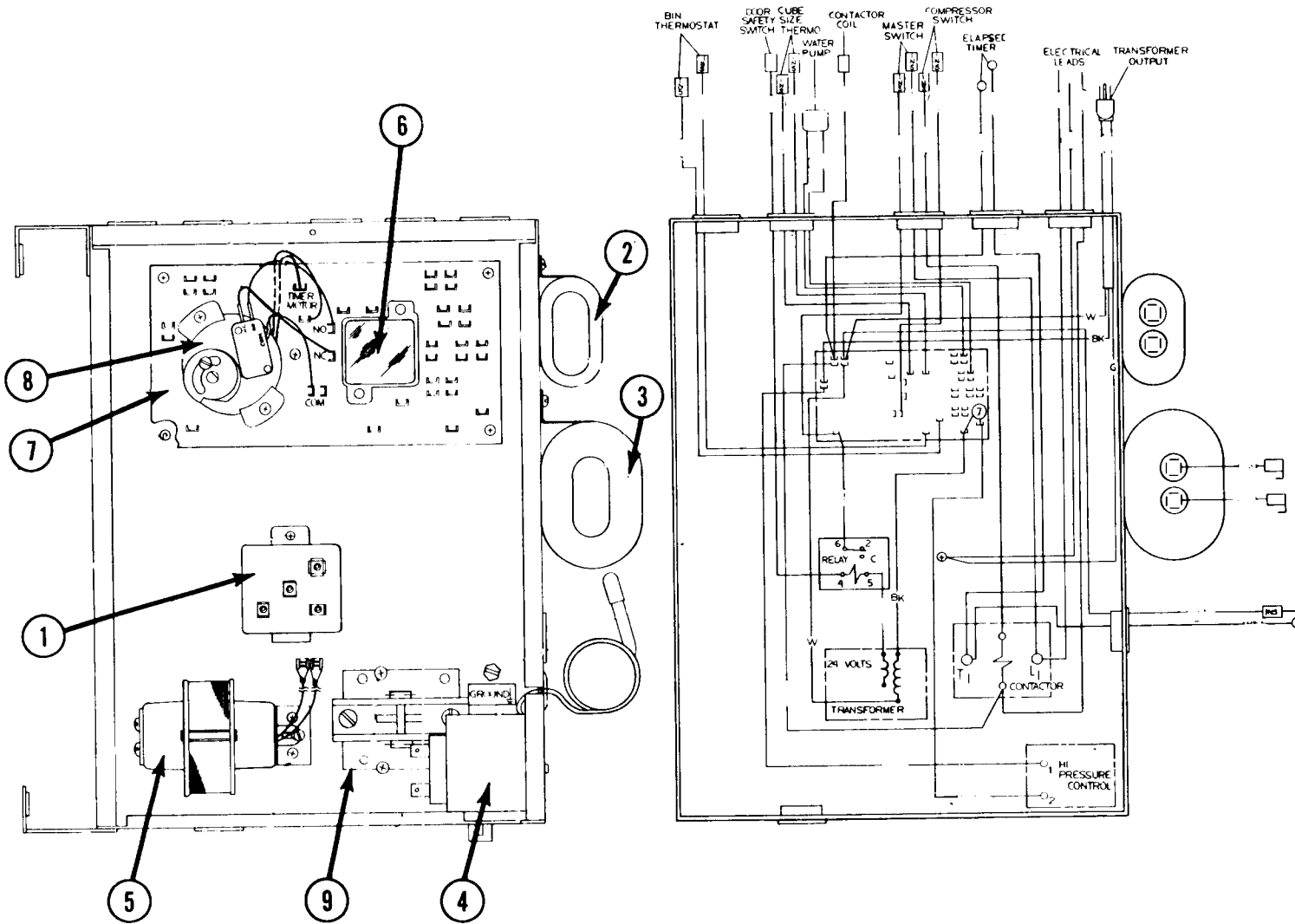

ITEM NO.	PART NO.	DESCRIPTION
1.	12-1873-01	Relay
2.	18-3701-01	Capacitor
3.	18-1902-17	Capacitor
4.	11-0357-03	Pressure Control
5.	12-1809-00	Transformer
6.	12-1879-02	Relay 3 PDT
7.	12-1912-01	Circuit Board
8.	12-1979-31	Timer
9.	12-2041-01	Contactor

# WIRING DIAGRAM 115/60/1

## Water Cooled Models

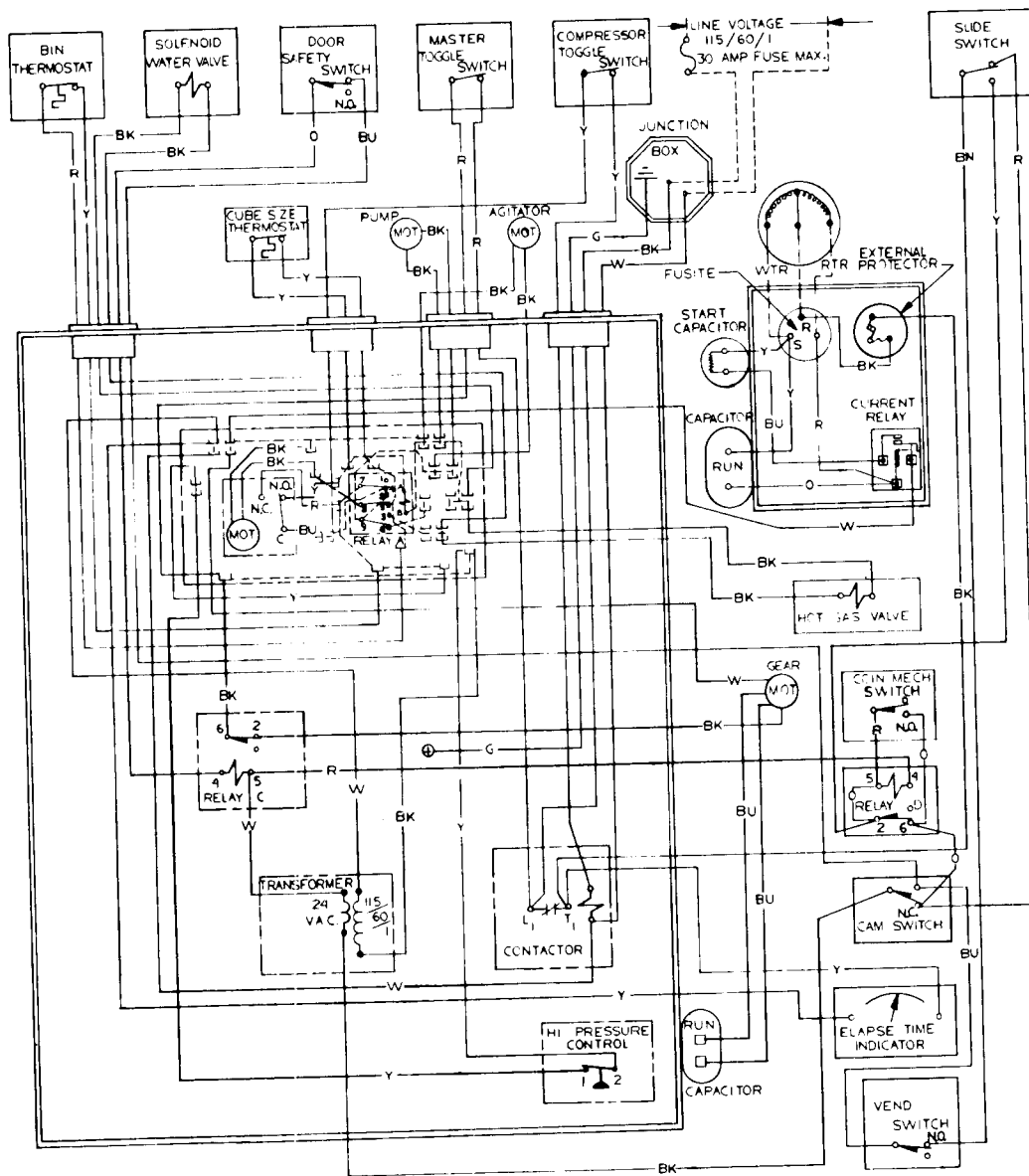

WIRING DIAGRAM / NOTE: SEE INSTRUCTION SHEET #17-1296-01 FOR WIRING DIAGRAM USED WITH KEY MECHANISM

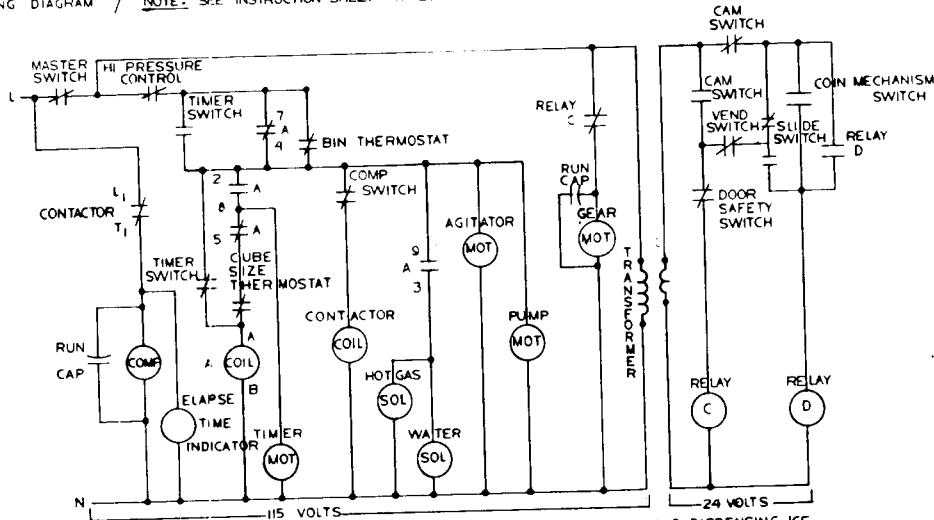

SCHEMATIC DIAGRAM WITH UNIT IN TIMED PORTION OF FREEZING CYCLE AND DISPENSING ICE  
**THIS UNIT MUST BE GROUNDED**

A27046-001

# CONTROL BOX ASSY.

## Air Cooled

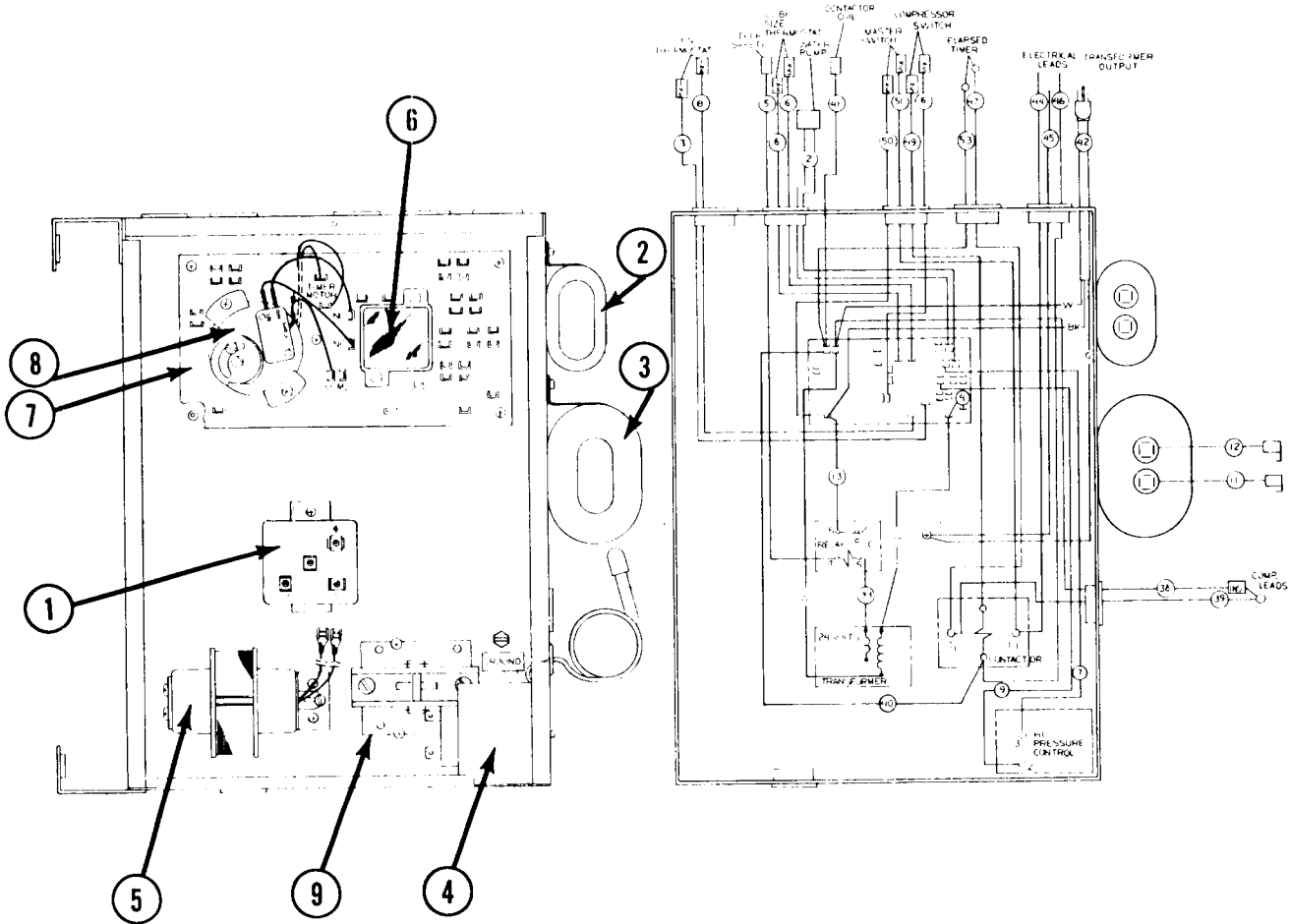

ITEM NO.	PART NO.	DESCRIPTION
1.	12-1873-01	Relay
2.	18-3701-01	Capacitor
3.	18-1902-17	Capacitor
4.	11-0352-01	Pressure Control
5.	12-1809-00	Transformer
6.	12-1879-02	Relay 3 P.D.T.
7.	12-1912-01	Circuit Board
8.	12-1979-31	Timer
9.	12-2041-01	Contactor

# WIRING DIAGRAM

## Air Cooled Models

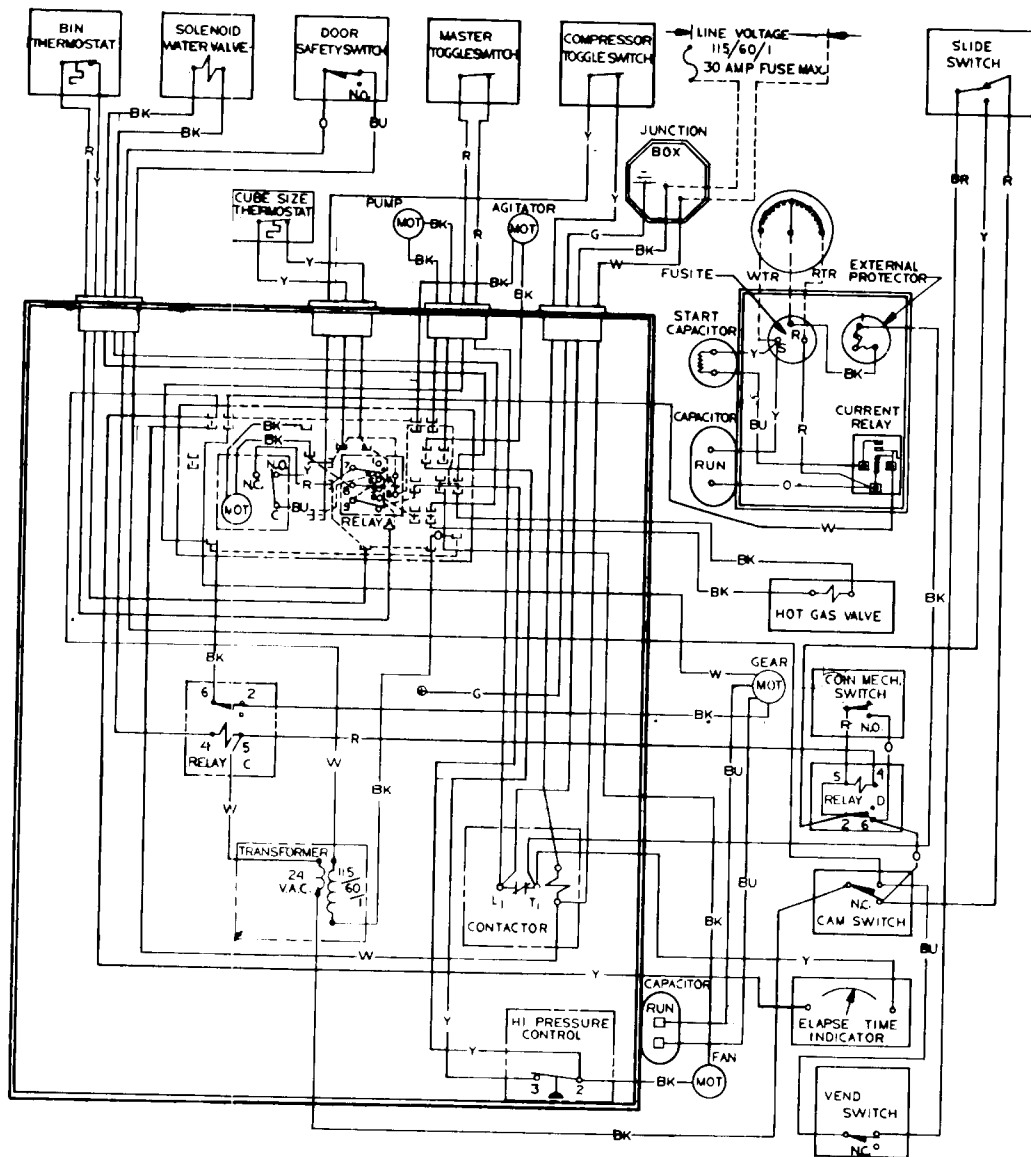

WIRING DIAGRAM / NOTE: SEE INSTRUCTIONS SHEET #17-1296-01 FOR WIRING DIAGRAM USED WITH KEY MECHANISM

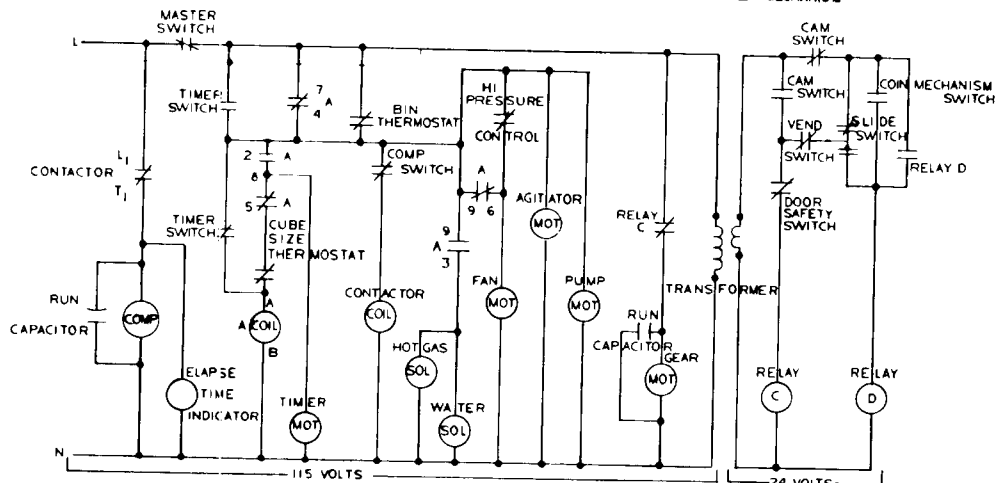

SCHEMATIC DIAGRAM WITH UNIT IN TIMED PORTION OF FREEZING CYCLE AND DISPENSING ICE  
**THIS UNIT MUST BE GROUNDED**

A27040-001



**POSSIBLE CAUSE**

**SUGGESTED CORRECTION**

**CUBES TOO LARGE**

Cube size control turned too cold ..... Turn setting on cube size control dial towards warmer

**DECREASED ICE CAPACITY**

Inefficient compressor ..... Replace  
 High head pressure ..... Dirty condenser. Clean. Bad fan motor. Replace  
 Non-condensable gas in the system ..... Purge the system  
 Poor Air circulation or excessively hot location ..... Relocate the unit, or provide for ventilation by cutting openings  
 Overcharge of refrigerant ..... Correct the charge. Purge off slowly  
 Partially restricted cap tube ..... Purge & replace charge and drier

**HOLE WASHED INSIDE CUBE**

Water over the top of the cube cups during harvest ..... Level unit

**POOR HARVESTS**

Too short defrost time ..... Check and adjust harvest cycle  
 Timer should be set at number 3  
 Restriction in incoming water ..... Check water feed line strainer and flow reducing valve. Do not remove flow control washers.

**UNIT WILL NOT RUN**

Blown fuse in building supply ..... Replace fuse & check for cause of blown fuse  
 Switch in Off position ..... Turn switch to On Position  
 Inoperative master switch ..... Replace switch  
 Timer contacts open ..... Replace timer micro-switch

**COMPRESSOR CYCLES INTERMITTENTLY**

Low voltage ..... Check circuit for overloading. Check voltage at the supply to the building. If low, contact the power company.  
 Dirty condenser .... Clean with vacuum cleaner, air or stiff brush. (Do NOT use wire brush.)  
 Air circulation blocked ..... All sufficient air space all around unit.  
 Inoperative condenser fan motor ..... Check to see if defective, if defective, replace  
 Non-condensable gases in system ..... Purge the system

**CUBES TOO SMALL**

Cube size control set too high ..... Lower the setting. Turn towards colder  
 Partially restricted capillary tube ..... Blow charge, add new gas & drier, after evacuating system with suction pump  
 Moisture in system ..... Same as above  
 Shortage of water ..... See remedies for shortage of water  
 Shortage of refrigerant ..... Check for leaks and recharge

**CLOUDY CUBES**

Shortage of water ..... See remedies for shortage of water  
 Dirty water supply ..... Use water softener or water filter  
 Accumulated impurities ..... Use SCOTSMAN Ice Machine Cleaner

**SHORTAGE OF WATER**

Water spraying out through curtains ..... Hang curtain in proper position  
 Partial restrictions in water strainer ..... Clean Strainer  
 Water pump not opening ..... Check pump for proper operation

**IRREGULAR SIZE CUBES AND SOME CLOUDY**

Some jets plugged ..... Clean jets  
 Shortage of Water ..... See Shortage of Water  
 Unit not level ..... Water overflowing air vent holes on low side burning cubes. Level as required

**EVAPORATOR FREEZE UP**

Several spray jets plugged ..... Clean jets  
 Shortage of water ..... See shortage of water

## PARTS LIST

### PUMP ASSY.

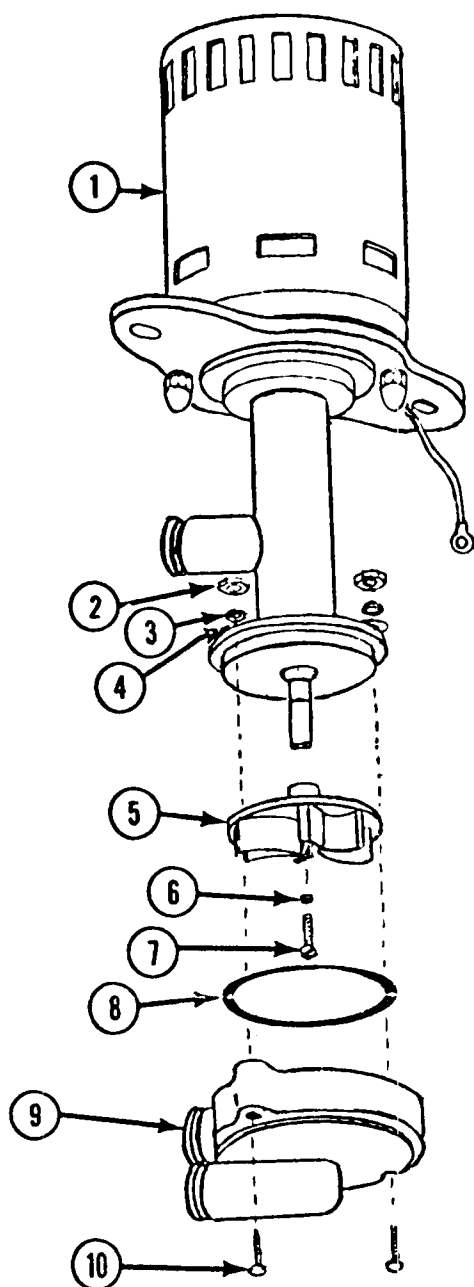

ITEM NO.	PART NO.	DESCRIPTION
1.	12-1930-01	Pump Assy. Complete
2.	12-1849-54	Nut (Hex)
3.	12-1849-55	Lock Washer
4.	12-1849-56	Washer
5.	12-1849-57	Impeller
6.	12-1849-58	Lock Washer
7.	12-1849-59	Screw
8.	12-1849-60	"O" Ring Seal
9.	12-1849-61	Pump Housing
10.	12-1849-62	Screw

### MOTOR COMPRESSOR Air and Water 3500 RPM — 115/60/1

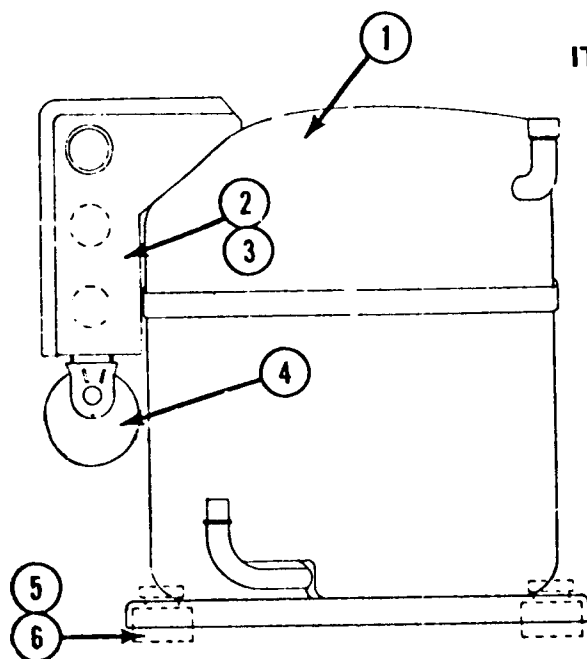

ITEM NO.	PART NO.	DESCRIPTION
1.	18-3900-01	Compressor Complete Cope. No. RSL2-0075-1AA-233
2.	18-2400-25	Overload Cope. No. 071-0127-06
3.	18-2410-00	Relay — Start Cope. No. 040-0098-01
4.	18-2420-00	Capacitor — Start Cope. No. 014-0008-69
5.	18-2200-27	Metal Sleeve Cope. No. 027-0072-02
6.	18-2200-28	Rubber Mount Cope. No. 027-0073-00

### 15-0609-01

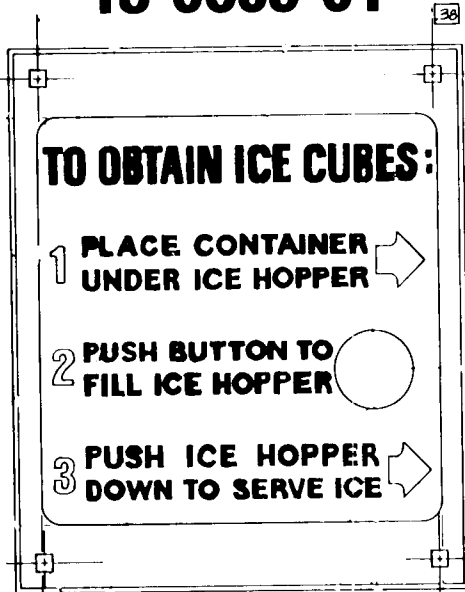

**PUSH BUTTON  
OPERATION**

### 15-0609-02

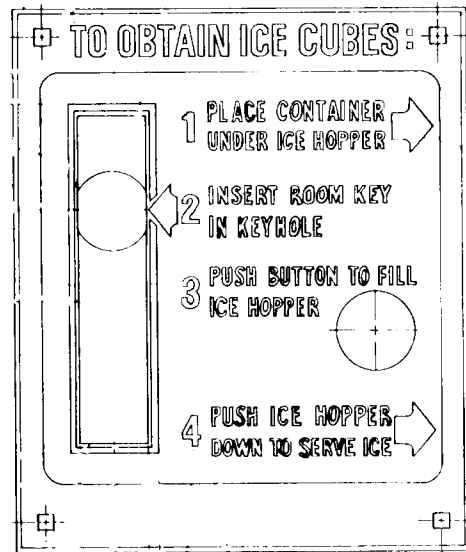

**FOR KEY  
OPERATION**

### 15-0609-03

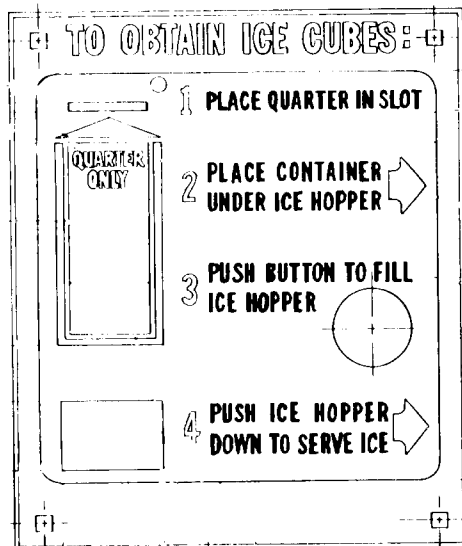

**FOR COIN OPERATION**

## INSTRUCTIONS FOR CHANGING TO COIN MECHANISM OPERATION

**Items Furnished:** Items necessary for changing to coin operation are in the envelope inside the lower door.

**Step 1** — Disconnect machine from power source.

**Step 2** — Remove existing graphics plate and mount new graphics plate with square opening, using carriage bolts provided.

**Step 3** — Move slide switch, located behind door, to "Coin Operation".

This completes the conversion.

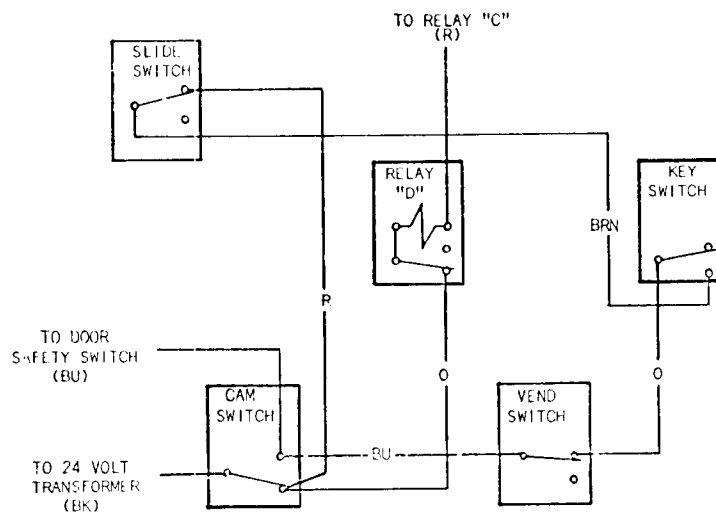

CD20 ICE DISPENSER WIRING DIAGRAM AND SCHEMATIC  
FOR INSTALLATION OF DOOR KEY MECHANISM

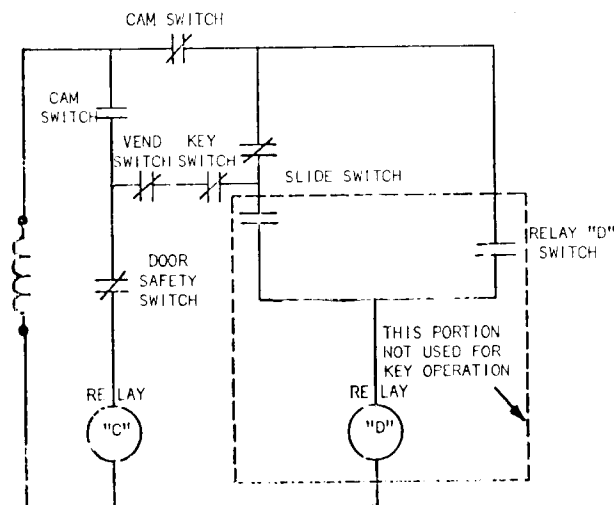

## INSTRUCTIONS FOR INSTALLATION OF THE DOOR KEY MECHANISM ON CDM20 ICE DISPENSERS

**Items Furnished:** Items necessary for hook-up of these mechanisms are packed inside coin box on lower door assembly — graphics plates, wiring diagram and instructions are also inside lower door in envelope.

- Step 1** — Disconnect machine from power source.
- Step 2** — Remove existing graphics plate and coin mechanism.
- Step 3** — Mount new graphics plate with double "D" opening using new carriage bolts supplied.
- Step 4** — Insert cylinder mount through double "D" from front of machine, add switch bracket and nut on inside of machine.
- Step 5** — Remove switch, bolts and nut strap from coin mechanism. Bolt switch to switch bracket with electrical insulation between switch and bracket.
- Step 6** — Move brown wire from vend switch to N.O. contacts on key switch.
- Step 7** — Remove yellow wire that is connected to the slide switch and relay "D".
- Step 8** — Remove the red wire that is connected to the coin switch and relay "D".
- Step 9** — Remove the orange wire that is connected to the coin switch and relay "D". Use this wire from N.O. on the vend switch to common on the key switch.
- Step 10** — Install key barrel, cut per attached sketch, in cylinder mount and secure with set screw.
- Step 11** — See additional pages for sketches and wiring diagrams.  
**This completes the conversion.**

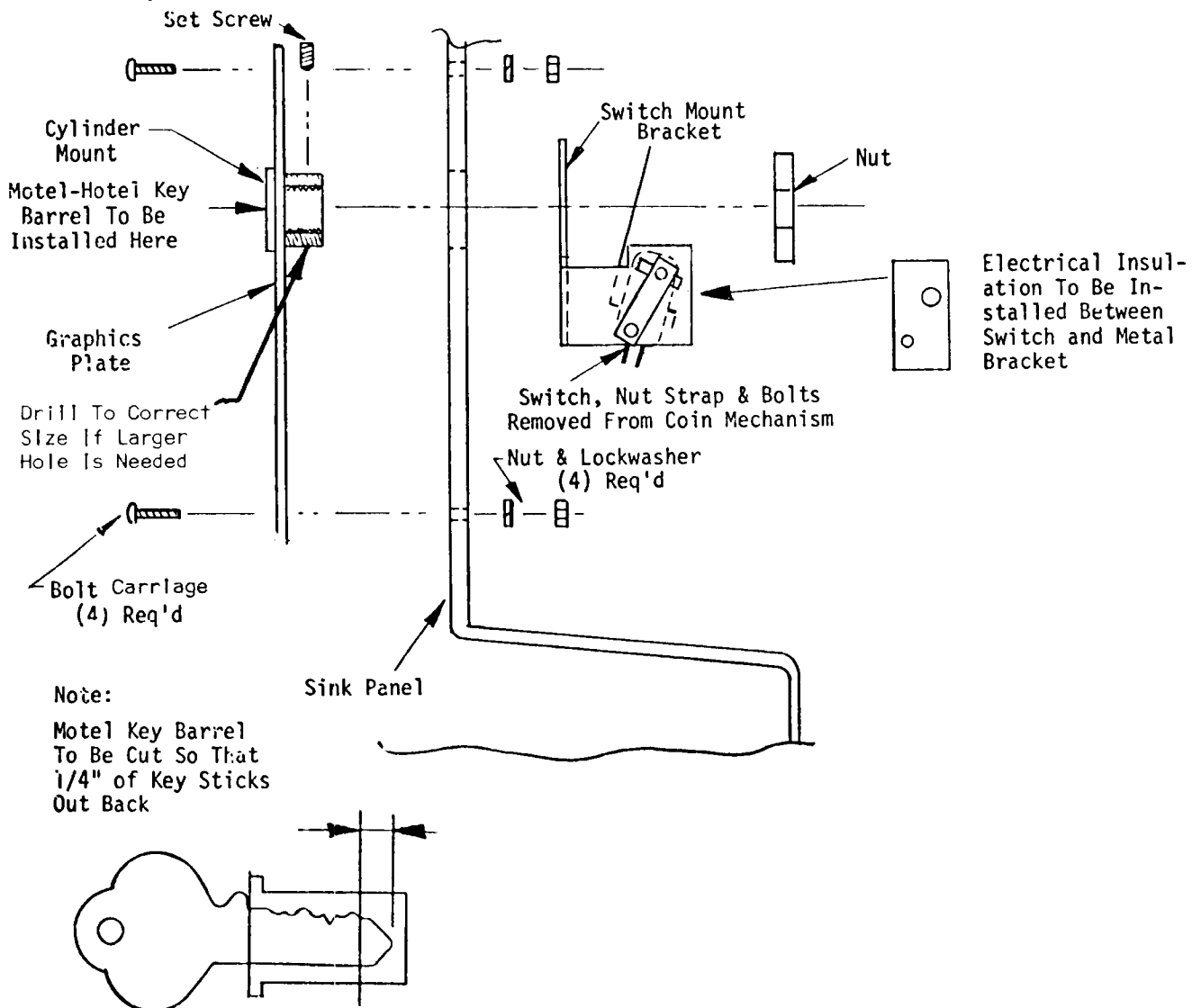

## FUNCTIONAL PARTS AND MAINTENANCE

**PART NAME:** Agitator Drive Motor — Merkle Korff — 40 RPM.

**NUMBER:** A24743-001

**FUNCTION:** This motor thru drive linkage member, rocks spray bar (jet tube) assembly during freezing cycle causing a continuous washing action across ice cup molds. Correction to spray bar travel is made by unhooking threaded friction catch linkage arm on either end and adjusting accordingly.

**SETTING:** No settings on motor.

**REPAIRABLE:** Yes -to some extent. Not recommended although front bearings and windings could possibly be replaced by electric motor shop. Normally replace motors.

**MAINTENANCE:** Oil every six months or less as use indicates. Use SAE 20 oil. There is a gear case slotted screw which has to be removed to add or change oil in gear case proper. Drive linkage should be inspected to insure free movement with no bindings or drag on drive motor.

**PART NAME:** Time-Finishing Clock — Manufactured by Queen Products Div.

**NUMBER:** 12-1979-31

**FUNCTION:** Heart of cyclematic control system is the reverse acting cube size control, No. 11-345, and the time clock it actuates. All electrical components are connected to the time clock terminal board and are shunted by means of a double pole single throw micro-switch to either the freezing cycle or harvest cycle. Micro-switch is in turn actuated by a brass cam that is directly connected to the electric timer clock motor. Timer has 15 minute cycle, 12 minutes on freezing cycle after being cut on by low temperature control and 3 minutes on defrost cycle.

The cam assembly on the timer consists of two discs which can be adjusted to lengthen or shorten the defrost cycle.

**SETTING:** Normal setting from defrost is on No. 3 which is 3 minutes.

**REPAIRABLE:** No. Replace when inoperative.

**MAINTENANCE:** Check all electrical connections, blow contact points free of dust, dirt, etc.

**PART NAME:** Cube Size Thermostat

**NUMBER:** 11-345-01

**FUNCTION:** Reverse acting temperature control, closes on temperature decrease, opens on temperature rise. Control determines length of freezing cycle and by the same token, the cube size. A lower setting on control will produce larger cubes, a higher setting, smaller cubes. This control actuates time clock motor, Part No. 12-1979-31, which then takes over balance of freezing cycle (12 minutes) and also defrost period 3 minutes.

**SETTING:** Adjustable by screw driver slot.

**REPAIRABLE:** No. Replace when inoperative.

**MAINTENANCE:** Check electrical connections. Blow points free of dust, dirt, lint, etc.

**PART NAME:** Contactor

**NUMBER:** 12-2041-01

**FUNCTION:** Across the line contactor used to provide protection for hi voltage compressor only. Contactor is wired so any of the controls in pilot circuit such as bin thermostat will cause contactor holding coil to drop contact points when actuated. There are no overloads or resets on this control.

**SETTINGS:** Factory set, no adjustments necessary.

**REPAIRABLE:** No. Replace.

**MAINTENANCE:** Check control for loose electrical connections and blow free any dust, dirt, etc.

**PART NAME:** Hot Gas Solenoid Valve  
**NUMBER:** 12-2023-03

**FUNCTION:** The hot gas solenoid valve assembly is comprised of two parts, the valve body and solenoid coil. These components are located on the discharge line of the compressor and activated by the finishing timer during the harvest cycle. As the finishing timer advances into Harvest, the solenoid coil, located on top of the valve body, is energized, thereby, lifting the valve stem within the valve body. This allows for the hot discharge gas from the compressor to by-pass the capillary tube and flow directly into the evaporator, releasing the cubes from the cube molds.

**REPAIRABLE:** No. Replace.

**MAINTENANCE:** Check electrical connections.

**PART NAME:** Water Pump — 3000 RPM  
**NUMBER:** 12-1930-01

**FUNCTION:** Recirculating pump used to pump supply water in reservoir to jet tubes during freezing cycle, and harvest cycle.

**SETTING:** None.

**REPAIRABLE:** Yes, see parts breakdown.

**MAINTENANCE:** Flush out reservoir and pump intake with Scotsman ice machine cleaner.

**PART NAME:** Inlet Water Solenoid  
**NUMBER:** 12-1434-01

**FUNCTION:** During freezing cycle this valve is closed.

During harvest or defrost cycle this valve opens and allows inlet water to pass thru flow control orifice into back of cup molds, performing the defrost.

**SETTING:** Factory set. Flow control rated at .75 GPM.

**REPAIRABLE:** Yes

**MAINTENANCE:** Flush control each six months.

**PART NAME:** Fan Motor  
**NUMBER:** 12-1681-01

**FUNCTION:** Maintain proper head pressures by circulating air across air cooled condenser.

**REPAIRABLE:** No.

**MAINTENANCE:** None.

**PART NAME:** Water Regulating Valve (Water cooled models only)  
**NUMBER:** 11-0198-02

**FUNCTION:** To maintain constant head pressures by regulating amount of incoming water thru water cooled condenser.

**REPAIRABLE:** No. However, valve can be flushed out.

**MAINTENANCE:** None.

**PART NAME:** Hermetic Motor Compressor.  
**NUMBER:** 18-3900-01

**FUNCTION:** Circulates and retrieves refrigerant throughout entire system.

**MAINTENANCE:** Keep clean and free of dust, grease, etc.

**PART NAME:** Spray Bar Assembly  
**NUMBER:** A27288-001

**FUNCTION:** This tube acts as a water distributor for the ice cube cups. The tube has jets over its length. Supply water is forced into the jet tubes by the water pump and is directed upward in a continuous stream. Drive motor thru drive shaft moves the spray bar to get a full coverage spray.

**REPAIRABLE:** Yes, jets replaceable.

**MAINTENANCE:** All jets should be cleaned by running Scotsman Ice Machine Cleaner through unit. This step will eliminate hand cleaning. Partially plugged jets will produce cloudy or partial cubes. Wholly plugged jet will not produce a cube in cube cups it normally covers.

**PART NAME:** Spray Tube Drive Linkage.

**NUMBER:** Parts listed in parts section.

**FUNCTION:** Drives spray tube during freezing cycle to produce clear cubes and also drives spray tube during harvest cycle to assist defrost by agitating the ice cubes with water.

**REPAIRABLE:** No. Replace defective parts.

**MAINTENANCE:** None.

**PART NAME:** Relay.

**NUMBER:** 12-1879-02

**FUNCTION:** Relay is used as a by-pass on the bin thermostat when it tries to cut unit off on a full bin of cubes during a freezing cycle. This insures full cubes every time a harvest occurs and prevents short cycling on ice level control.

**SETTING:** Factory set.

**REPAIRABLE:** No. Replace when inoperative.

**MAINTENANCE:** Check electrical connections.

**PART NAME:** Bin Overfill Thermostat

**NUMBER:** 11-0399-01

**FUNCTION:** To automatically cut machine off when ice level in storage bin reaches thermobulb. Automatically starts machine when ice level in bin falls below bulb location.

**SETTING:** Factory set.

**REPAIRABLE:** No. Replace when inoperative or out of adjustment.

**MAINTENANCE:** Check capillary for cracks or worn spots due to vibration.

**NOTE:** Hold an ice cube against thermostat capillary tube to check operation of the control.



## **CLEANING INSTRUCTIONS FOR SCOTSMAN ICE MACHINE MODEL CD20**

1. Open both front access doors.
2. Locate control box with time clock knob protruding through cover.
3. Put unit through a harvest cycle manually. This may be done by slowly turning time clock knob clockwise until you hear the micro-switch actuator arm click into cam slot.
4. Let unit finish cube harvest cycle and start into freezing cycle. This will be approximately 5 minutes after Step No. 3 has been carried out. At this time turn the compressor switch off.
5. The ice discharge opening is covered by a series of white plastic curtains which are free to swing out into the storage bin. Locate the water reservoir which is in the lower left corner directly behind the ice discharge opening. Pour 8 ounces (one bottle) of "Scotsman Ice Machine Cleaner" into the water reservoir.
6. Let unit operate normally for 10-15 minutes into the freezing cycle. No ice will be made because the motor compressor is not in operation.
7. At the end of this time, rotate the timer knob until the defrost cycle starts. Allow machine to run normally through this part of the cycle in the timer. When the defrost cycle has been completed, then rotate the knob manually through the freeze cycle until the defrost cycle starts again. Do this 3 times. Note that during freeze cycle, water is being sprayed into the cube forming cups.
8. Turn the compressor switch back on.
9. Check each new batch of cubes until they are clear and until acid taste has been removed from cubes
10. Put hot water in storage bin to melt the cubes. This cleans the drains with the same solution that has just cleaned the unit.
11. Clean storage bin with a long handled nylon bristle brush.
12. Damp wipe curtains and inside of storage bin.
13. Close all access doors.
14. Unit is now ready for continued automatic operation.

# CLEANING INSTRUCTION

CD20  
Page 41

## BIN-ROTOR AREAS

1. Vend all ice from CD20.
2. Remove left side panel, open front top and lower hinged panels (Refer to pages 10-11 of uncrating — set up instructions).
3. Rotor Removal.  
Remove rotor by removing large nut located in the center of the rotor. Care must be taken in noting position of the ice discharge opening on the rotor in relation to cam notch on the gear motor when removing rotor.
4. Cleaning storage bin and rotor.  
Scrub all areas of bin and rotor with ordinary cleaning powder, such as Bon-Ami and water. (Do not use cleaners that contain bleaching agents, as most of these are compounds of chlorine.) After cleaning, rinse thoroughly with clear water.
5. Rotor replacement.  
Replace rotor in unit with ice discharge opening on the rotor positioned with cam notch on gear motor. Failure to retain same position as when removed will cause abnormal vend operations. Hand tighten large nut in the center of the rotor.
6. Close top and bottom front doors, lock in place with wing screws provided, replace left side panel.

## CD20 CUBER SECTION

### MAINTENANCE INSTRUCTION FOR SCOTSMAN CUBERS

THE FOLLOWING MAINTENANCE SHOULD BE SCHEDULED EACH (6) SIX MONTHS ON ALL SCOTSMAN CUBERS. CALL YOUR AUTHORIZED SCOTSMAN SERVICE DEPARTMENT.

1. Clean air-cooled condenser. This is to be done frequently with the machine shut off.
2. Clean water system and evaporator, water tank and screen, using Scotsman Ice Machine Cleaner or equivalent.
3. Remove jet tube and manually clean jets.
4. Check curtain assembly.
5. Tighten all electrical connections.
6. Tighten all bolts.
7. Check water supply. Check water pressure. Clean water strainer.
8. Oil jet tubes drive motor. Use SAE 20 oil - 1 oil cup.
9. Oil Condenser fan motor. Punch sealed cap or remove screws where possible.
10. Check for refrigeration leaks.
11. Check for water leaks. Tighten drain line connections.
12. Check size and condition of cubes. Adjust as required.
13. Check bin thermostat setting by holding ice on bulb.
14. Check through two complete dispense cycles to insure all components are functioning properly.