

# CM1400

## TABLE OF CONTENTS

<b>INTRODUCTION SECTION</b>	
Specifications .....	3
<b>INSTALLATION SECTION</b>	
For the Installer .....	2
For the Electrician .....	6
For the Plumber .....	8
Final Checklist .....	10
<b>START-UP SECTION</b>	
Start-Up .....	12
Adjustment of Cube Size .....	14
<b>MAINTENANCE &amp; CLEANING INSTRUCTIONS</b>	
General .....	16
Icemaker .....	16
Cleaning - Icemaker .....	17
<b>OPERATION</b>	
Freezing Cycle .....	20
Harvest Cycle .....	21
Operating Characteristics .....	25
Beginning Freeze .....	23
Timed Freeze .....	24
Harvest Cycle .....	24
Component Description .....	26
Service Diagnosis .....	30
<b>ADJUSTMENT PROCEDURES</b>	
Cube Size Control .....	32
Timer and Switch Assembly .....	32
Water Regulator Assembly - Water-Cooled ...	33
<b>REMOVAL AND REPLACEMENT PROCEDURES</b>	
Bin Thermostat Control .....	33
Compressor Assembly .....	33
Condenser - Air-Cooled .....	33
Condenser - Water-Cooled .....	34
Cube Size Control .....	34
Drier .....	34
Evaporator Plate Assembly .....	36
Fan Motor - Air-Cooled .....	36
Inlet Water Solenoid Valve .....	36
Water Distributor Tubes and Manifold Tubes .....	37
Water Pump Assembly .....	37

## LIST OF ILLUSTRATIONS

Component Location .....	2
Specifications .....	3
Mounting Cuber to Bin .....	4
Electrical Connections .....	6
Installation, Water Supply and Drain Connections .....	8
Final Checklist .....	11
Timer Cam Positions .....	12
Cube Size Control Adjustment .....	14
Maintenance and Cleaning .....	17
<b>PARTS LIST AND WIRING DIAGRAMS</b> .....	1
(Printed in Yellow)	
<b>PARTS LIST:</b>	
Component Location .....	2
Cabinet Assembly .....	3
Refrigeration System .....	4
Air-Cooled Assembly .....	5
Water-Cooled Assembly .....	5
Water System .....	6
Control Box .....	7
Bins, BH750/BH1000 .....	8
<b>WIRING DIAGRAMS:</b>	
CM1400AE-3A (208-230/60/3) .....	9
CM1400WE-3A (208-230/60/3) .....	10
CM1400AE-32A (208-230/60/1) .....	11
CM1400WE-32A (208-230/60/1) .....	12
Freezing Cycle .....	20
Harvest Cycle .....	21
Component Description .....	27
Optional Bins .....	38

**THIS PAGE  
INTENTIONALLY  
LEFT BLANK**

# CM1400 FOR THE INSTALLER

## INTRODUCTION

These instructions provide the specifications and the step-by-step procedures for the installation, start up and operation for the Scotsman Model CM1400 Modular Cuber.

The Model CM1400 Modular Cubers are quality designed, engineered, constructed, and are thoroughly tested icemaking systems providing the utmost in flexibility to fit the needs of a particular user.

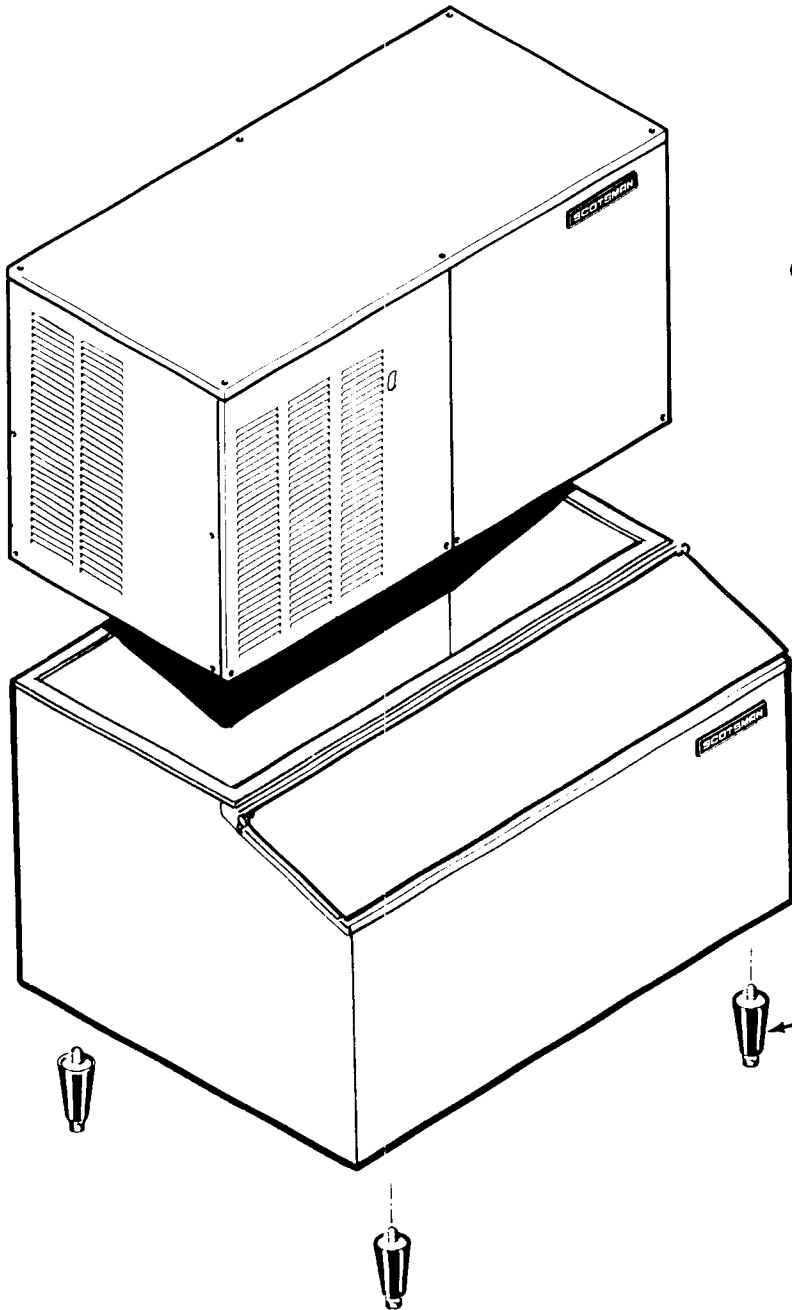

CM1400 MODULAR CUBER

BH750 STORAGE BIN  
OR  
BH1000 STORAGE BIN

ADJUSTABLE LEGS

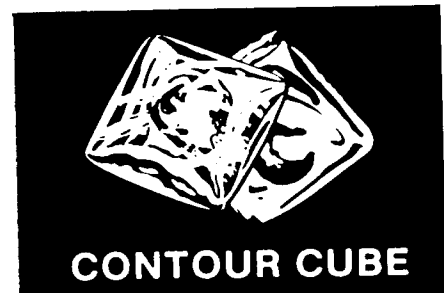

# CM1400 FOR THE INSTALLER

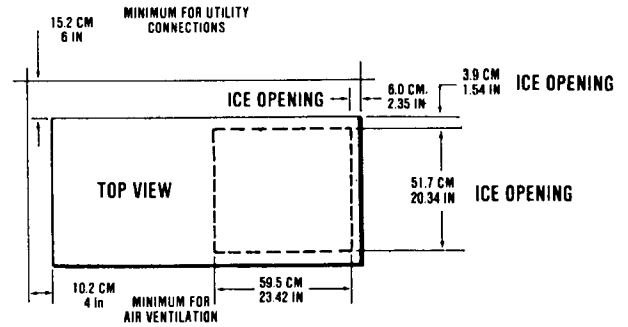
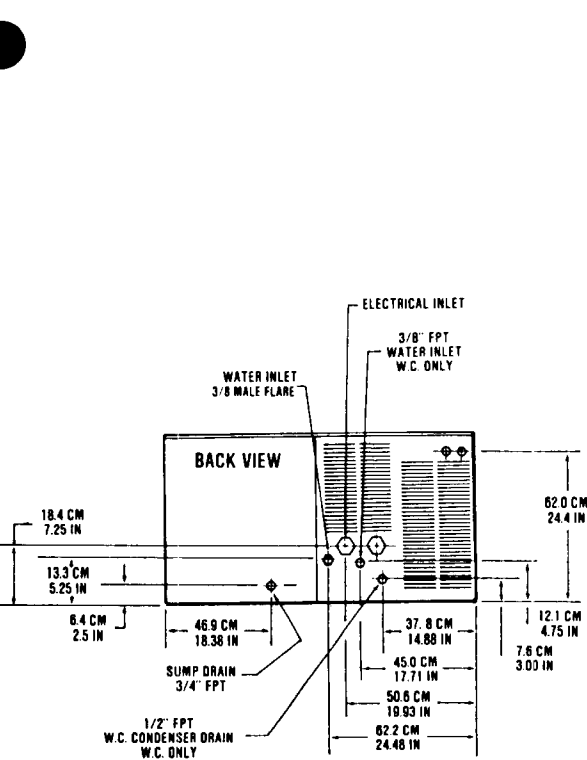

LEFT SIDE VIEW

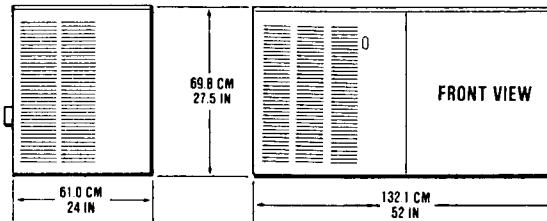

## SPECIFICATIONS

Model Number	(Height - w/o Legs) Dimensions H" x W" x D"	Bin Cap.	Cube Size	Cond. Unit	Finish **	Basic Electrical	Comp. H.P.	No. of Wires	Min. Circuit Ampac- ity †	Max. Fuse Size	Ship. Wt. lbs./kg.
CM1400AE-3A	28 x 52 x 24	—	Contour	Air	ES	208-230/60/3	3.25	3	14.4	20	370/168
CM1400WE-3A	28 x 52 x 24	—	Contour	Water	ES	208-230/60/3	3.25	3	13.2	15	370/168
CM1400AE-32A	28 x 52 x 24	—	Contour	Air	ES	208-230/60/1	3.25	2	24.6	30	360/163
CM1400WE-32A	28 x 52 x 24	—	Contour	Water	ES	208-230/60/1	3.25	2	20.9	25	360/163

## MODULAR ICE STORAGE BINS

Model Number	(Height - w/o Legs) Dimensions H" x W" x D"	Bin Cap.	Finish	Ship. Wt. lbs./kg.
BH750E	29 3/4 x 52 x 36	734 lbs	ES	171/100
BH750S	29 3/4 x 52 x 36	734 lbs	SS	166/100
BH1000E	44 x 52 x 31 1/2	1000 lbs	ES	231/105
BH1000S	44 x 52 x 31 1/2	1000 lbs	SS	231/105

\*\* (ES) Sandalwood, Leathergrain embossed steel with high gloss baked enamel finish.

† Use this value to determine minimum wire size as per National Electric Code Standards

## OPTIONAL STAINLESS STEEL PANEL KIT

SPKCM1400 contains top, front and 2 end panels. Not factory installed.

## IMPORTANT OPERATING REQUIREMENTS

Air Temperatures . . . .	MINIMUM 50°F (10.0°C)	MAXIMUM 100°F (38°C)
Water Temperatures . .	40°F (4.4°C)	100°F (38°C)
Water Pressures . . . . .	20 lbs. gauge	120 lbs. gauge

### Electrical Voltage Variation

Voltage rating specified on nameplate . . . . .	-5%	10%
---	-----	-----

Extended periods of operation exceeding these limitations constitutes misuse under the terms of Scotsman Manufacturer's Limited Warranty, resulting in a loss of warranty coverage.

## STORAGE BIN

The CM1400 stacks onto Scotsman bin model BH1000.

Scotsman Ice Systems are designed and manufactured with the highest regard for safety and performance. They meet or exceed the standards of U.L., N.S.F., and C.S.A. Scotsman assumes no liability of any kind for products manufactured by Scotsman that have been altered in any way, including the use of any parts and/or components not specifically approved by Scotsman.

Scotsman reserves the right to make design changes and/or improvements at any time. Specifications and designs are subject to change without notice.

# CM1400 FOR THE INSTALLER

## LOCATION & LEVELING

1. Position the Model BH750 or BH1000 Bin in the selected location, which should have a minimum room temperature of 50-degrees F. and maximum room temperature of 100-degrees F. Level the bin, adjusting the leg levelers in both the front-to-back and side-to-side directions.
2. Inspect the bin top mounting gasket which should be flat with no wrinkles to provide a good water seal when the CM1400 Cuber is installed on top of the bin.
3. Install the CM1400 Modular Cuber on top of the BH750 or BH1000 Bin using care to be sure a good seal is made between the two cabinets. Align the holes in the bottom rear of the CM1400 cabinet to mate with the two mounting straps on the top rear of the BH750.
4. Bolt icemaker to bin with mounting straps and bolt from shipping skid. When alignment and leveling are completed, tighten the bolts to secure the mounting straps.

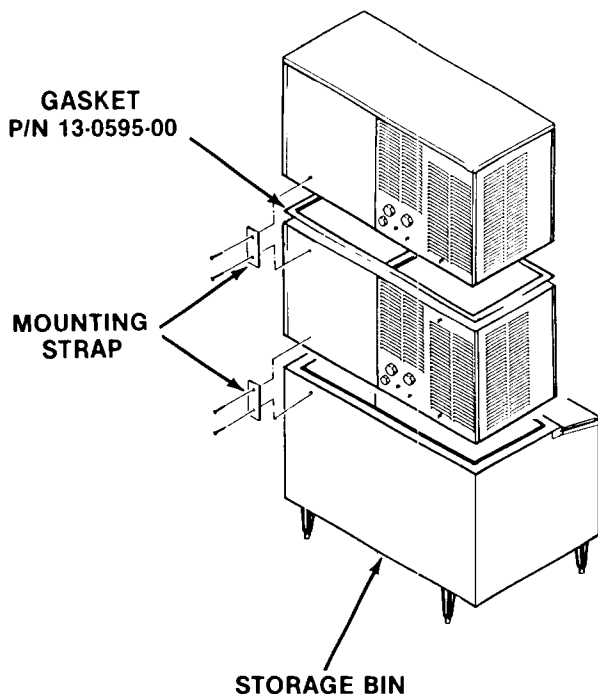

5. **STACKING INSTRUCTIONS, CM1400**  
When stacking two units, first remove the top panel from the bottom CM1400, and then remove the stainless steel liner top from that same unit. They will no longer have any function. Then either use gasket material 13-0595-00 (you will need about 15 feet) or food grade silicone rubber to make a seal on the top of the bottom unit. Carefully lift the uncrated top unit on to the bottom one, (use of a mechanical lift is recommended for this step) aligning the two so that the cabinets line up. Mount the upper unit bin control bracket assembly into the lower units bin control bracket. The lower units two front panels require four sheet metal screws to be added to the top of the panels to secure them to the icemaker. Fasten the two units together using mounting straps as illustrated.

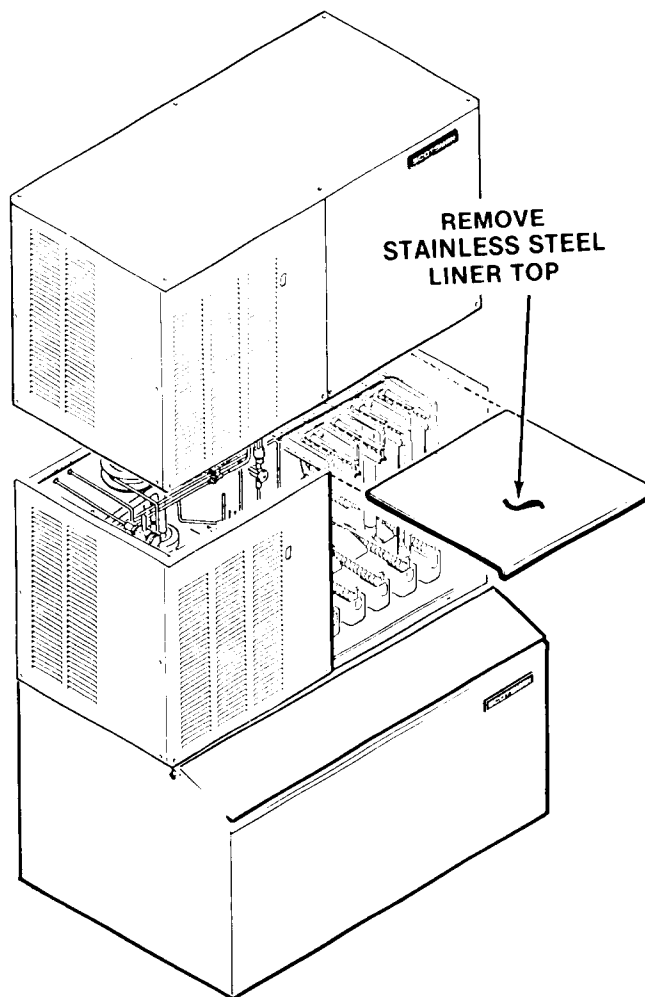

*Location & Leveling*

# CM1400 FOR THE INSTALLER

6. Remove bin thermostat bracket from shipping location on the evaporator supports.

Turn the three installed mounting brackets down to 6 o'clock position as illustrated.

Remove screw #1 shown and retain for use in attaching bracket.

Using screw #1, attach the bracket and tube assembly as shown and snap into the remaining three brackets.

Route the plastic tube thru the hole in the base (do not install on SS tube).

Insert approximately 28 inches of bin thermostat cap tube thru the plastic tube and then thru the stainless steel tube. The cap tube should extend the entire length of the stainless steel tube.

Install the plastic tube approximately 1 inch onto the stainless tube.

In stacking applications, run the cap tube through the top unit base and the lower unit control box as shown, using grommets provided. Then route both bin stat cap tubes through the same bracket.

7. Remove seven shipping supports from the evaporator supports.

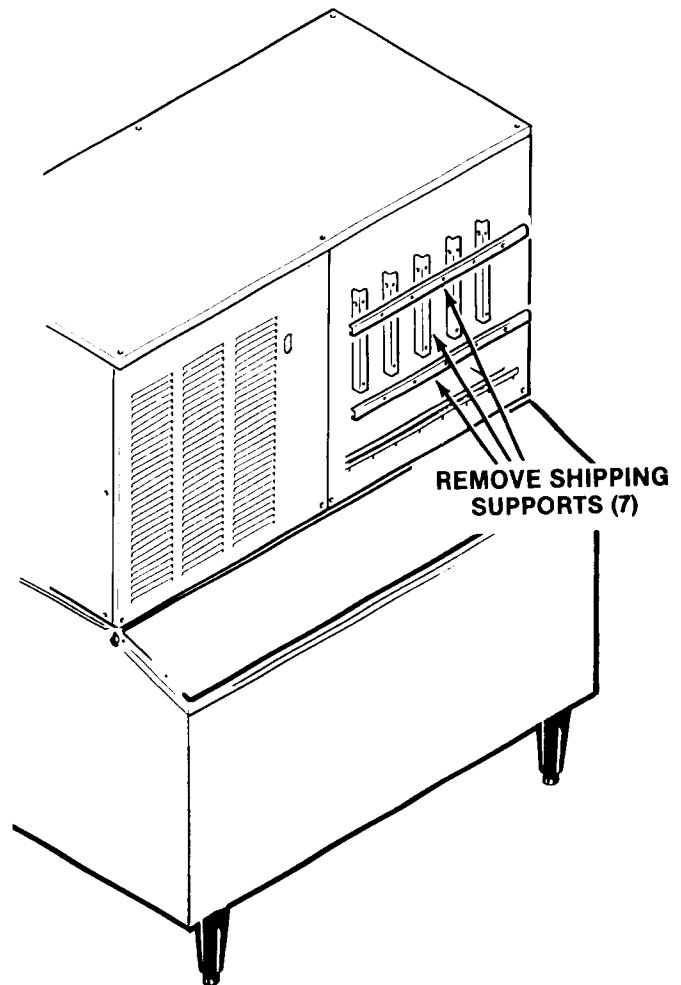

*Remove Shipping Supports*

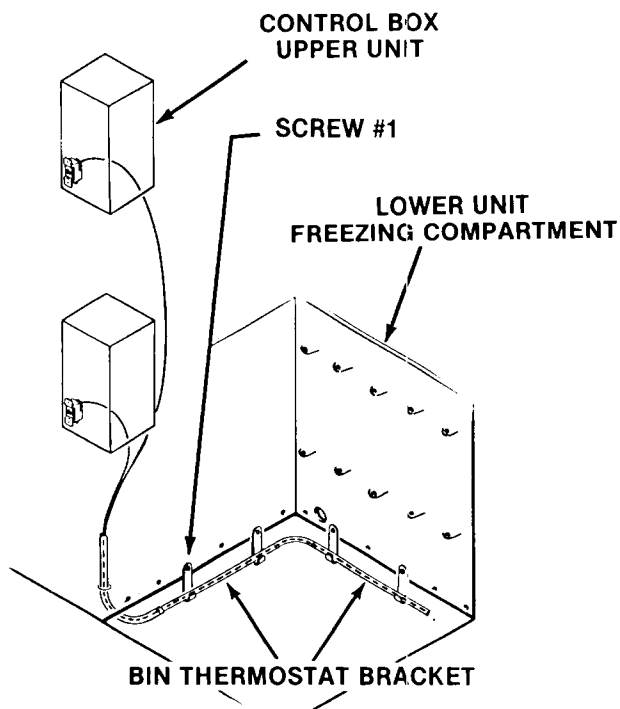

*Install Bin Thermostat Bracket*

# CM1400 FOR THE ELECTRICIAN

## ELECTRICAL CONNECTIONS

SEE NAMEPLATE for current requirements to determine wire size to be used for electrical hookup. The cuber requires a solid chassis-to-earth ground wire. See Wiring Diagram.

Be certain the cuber is connected to its own electrical circuit and individually fused. Voltage variation should not exceed  $\pm$  ten percent of the nameplate rating, even under starting conditions. Low voltages can cause erratic operation and may be responsible for serious damage to the icemaker.

**All external wiring should conform to the national, state and local electrical code requirements. Usually an electrical permit and services of a licensed electrician will be required.**

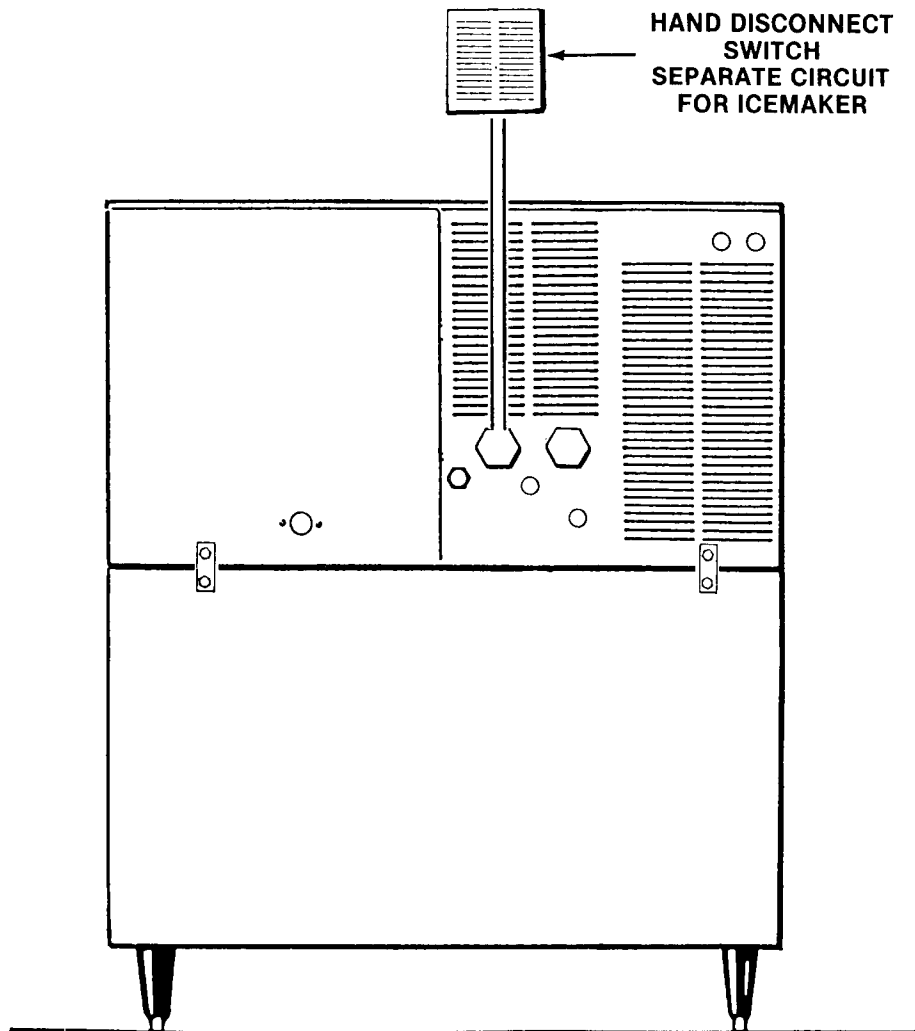





# CM1400 FOR THE PLUMBER

## WATER SUPPLY AND DRAIN CONNECTIONS

**AIR-COOLED MODELS:** The recommended water supply line is a 3/8" O.D. copper tubing. Connect to cold water supply line with standard plumbing fittings with a shutoff valve installed in an accessible place between the water supply and the cuber. In some cases a plumbing permit and services of a licensed plumber will be required.

**WATER-COOLED MODELS:** On water-cooled models, a separate cold water supply inlet is required, to be connected to a second 3/8-inch female pipe thread (FPT) fitting at the rear of the cabinet. Additional drain lines are required to drain the water-cooled condenser.

**DRAIN CONNECTIONS:** All drains are gravity type and must have a minimum of 1/4-inch fall per foot on horizontal runs. The drains to be installed to conform with the local plumbing code. Install a vertical open vent on drain line to insure good venting. The drain receptacle should be an open, trapped or vented construction.

Recommended bin drain is 3/4-inch O.D. copper tubing and should be vented and run separately.

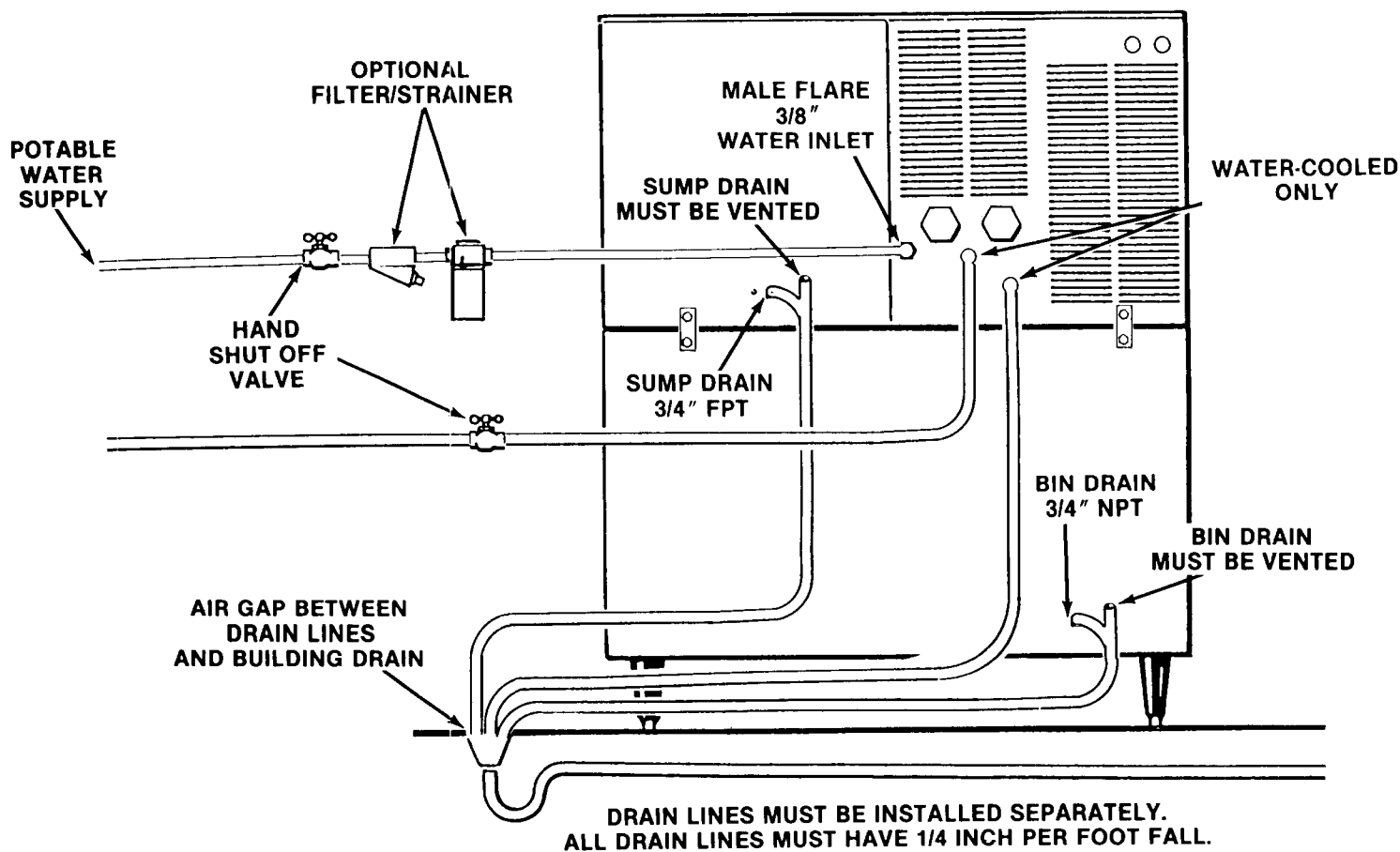

*Water Supply and Drain Connection*

# CM1400 FOR THE PLUMBER

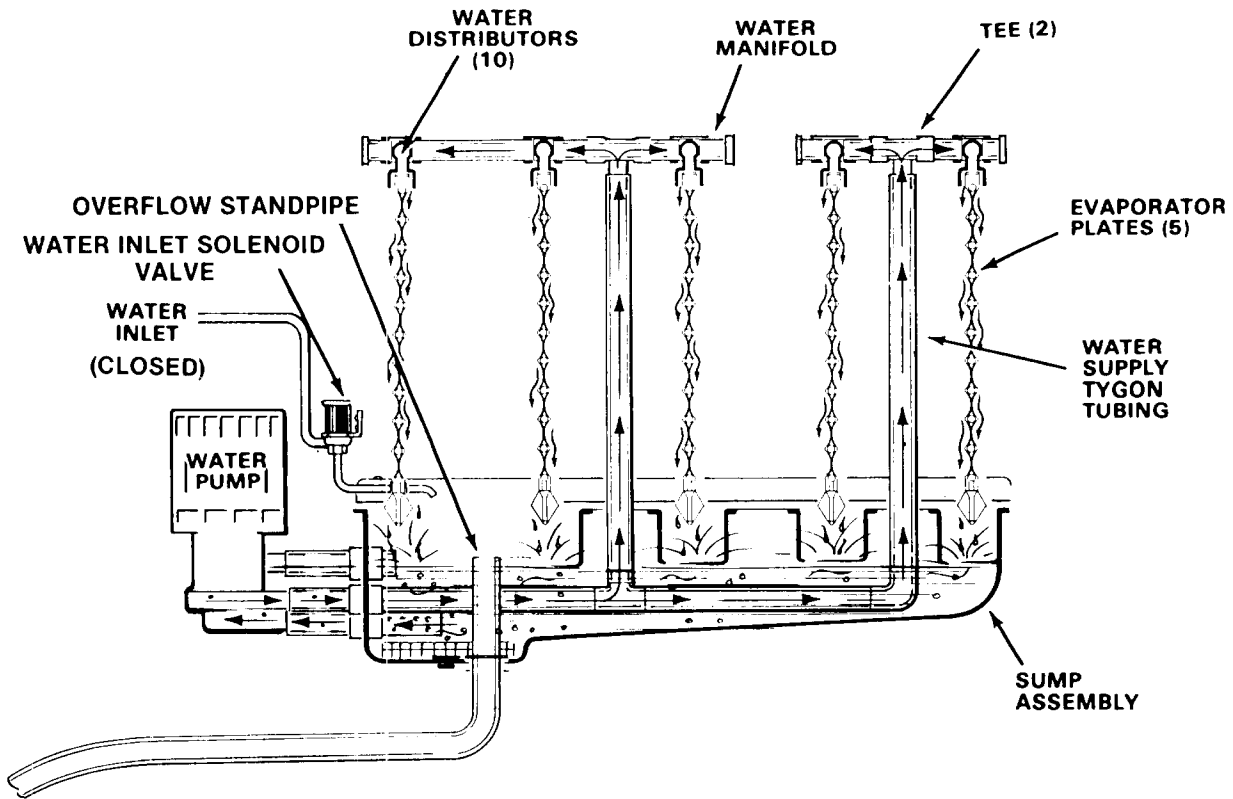

**FREEZING CYCLE**

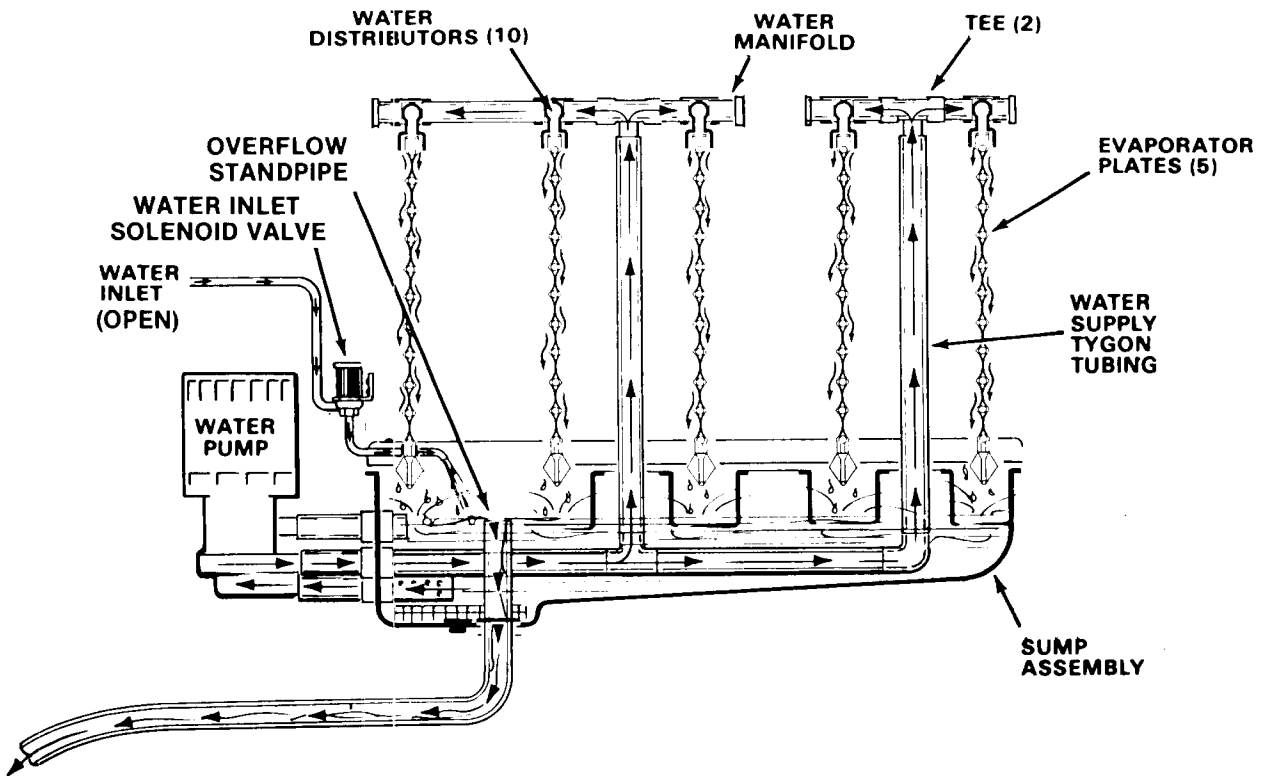

**HARVEST CYCLE**

*Freezing Compartment — Water Schematic*

# CM1400 FOR THE INSTALLER

## FINAL CHECK LIST

1. Is the cabinet/bin level?
2. Is the cuber in a location where ambient temperatures are a minimum of 50-degrees F. all year around and do not exceed a maximum of 100°F?
3. Is there at least a six-inch clearance behind and around the cabinet for all connections and for proper air circulation?
4. Have all electrical and piping connections been made?
5. Has the electrical power supply wiring been properly connected and the voltage tested and checked against the nameplate rating? Has proper chassis-to-earth ground been installed?
6. Is the water supply line shutoff valve installed and opened and has the inlet water supply pressure been checked to insure a minimum of 20 PSIG without exceeding a maximum of 120 PSIG?
7. Have the compressor holddown bolts been checked to be sure the compressor is snug on the mounting pads?
8. Check all refrigerant lines and conduit lines to guard against vibration and possible failure.
9. Has the bin thermostat bracket been properly installed?
10. Has the cuber and the bin been wiped clean with clean damp cloths?
11. Has the owner/user been given the User Manual and instructed on how to operate the icemaker and the importance of periodic maintenance?
12. Has the owner/user been given the name and telephone number of the Authorized Scotsman Distributor or Service Agency serving him?
13. Has the Manufacturer's Registration Card been properly filled out? Check for correct Model and Serial Numbers from nameplate, then mail the completed card to the SCOTSMAN factory.

# CM1400 FOR THE INSTALLER

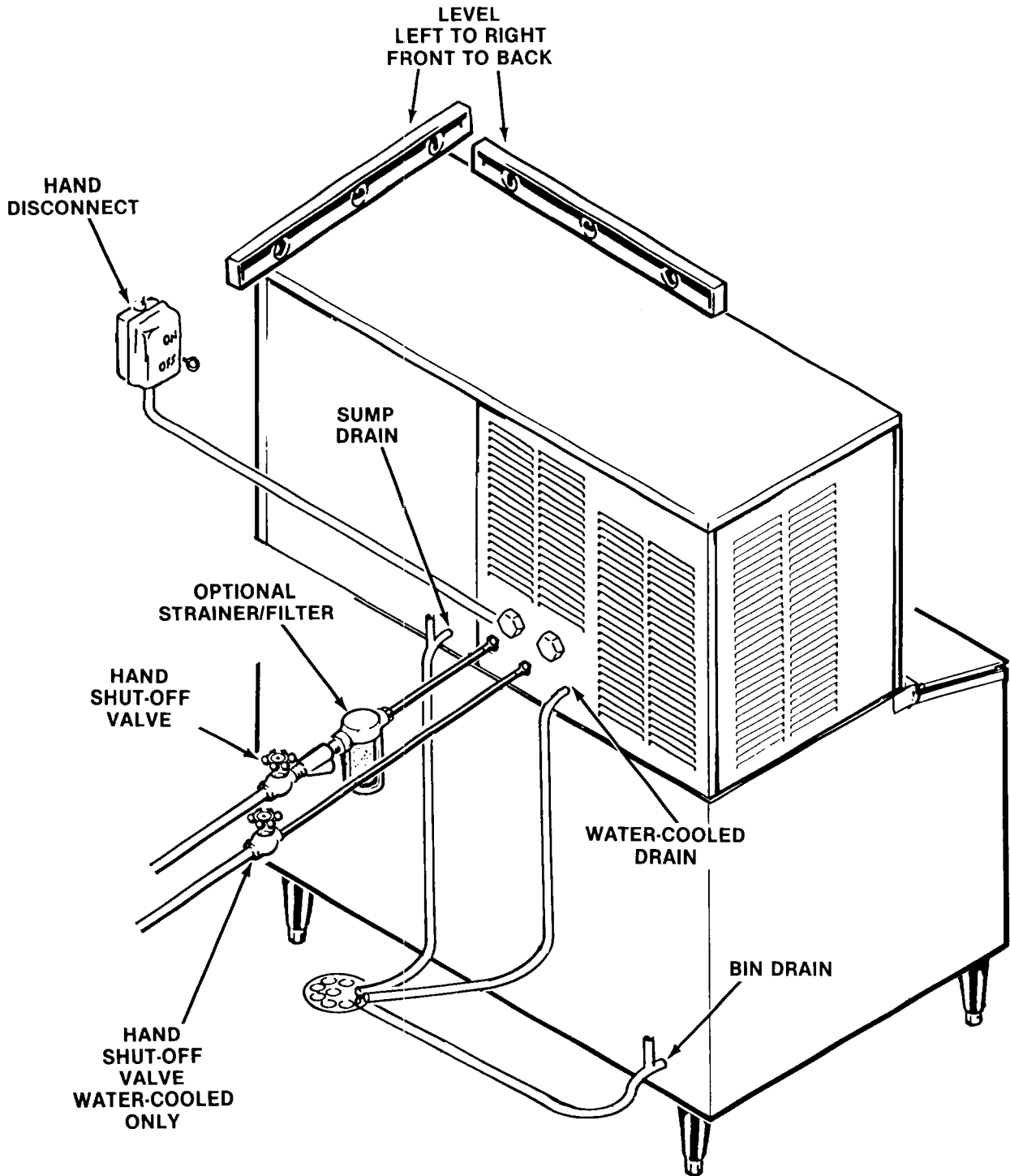

# CM1400 START-UP CHECK LIST

## START—UP

1. OPEN the water supply line shutoff valve.
2. Check that the two toggle switches, the MASTER ON-OFF toggle switch and the COMPRESSOR ON-OFF toggle switch are in the OFF position, on the control box.
3. Remove screws and remove both front panels.
4. Remove screws and remove the control box cover.
5. Inside the control box is the shaft of the timer and the switch assembly. Rotate the shaft of the timer and switch assembly clockwise until the actuator arm on the microswitch drops off outer cam into cam slot. See Timer Cam Positions. An audible click can be heard, but in a noisy area look at the cam and switch to observe the event.

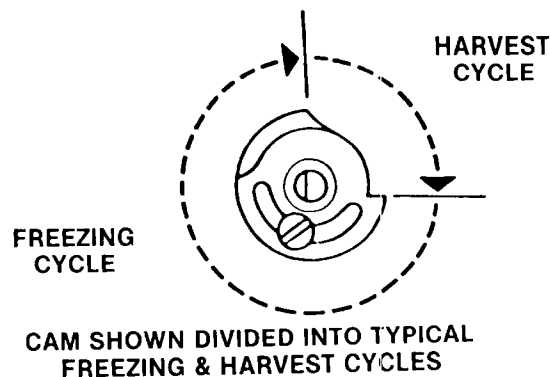
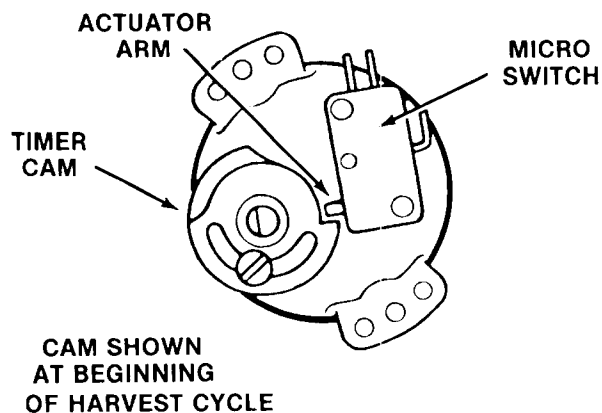

*Timer Cam Positions*

6. Move the master ON-OFF toggle switch, the bottom toggle switch, to the ON position.
7. Observe water fill cycle: Water inlet solenoid valve OPENS, incoming water flows from the valve through the tubing, the reservoir fills and excess water is overflowed through the stand pipe. This cycle will take about three minutes. Timer will close the water inlet solenoid valve and the water fill cycle is complete.

Advancing the shaft of the timer and switch assembly through the remaining cycle into a new harvest cycle, restarts the timer and allows a check that: Water inlet solenoid valve OPENS and the reservoir overflows through the stand pipe. Water inlet valve CLOSES, stopping water overflow.

8. Check that the water cascades down over each cube mold and into the sump.
9. When the second cycle is completed, move the compressor ON-OFF toggle switch, to the ON position.
10. Check operation of the freezing cycle:

The compressor is operating.

The water pump is operating, as seen by water moving through the two tygon tubes between evaporator plates, up to the water manifold at the top of the evaporator plates, where water is uniformly dispensed and cascades down both sides of each evaporator plate and drains back into the sump assembly for recirculation.

The icemaking process begins; feeling the metal parts of the evaporator plates reveals cold temperature, very shortly ice begins to form. Tubing will become frosted at the top of the evaporator plates.

Freezing time will range between 9 and 14 minutes in a 70-degree F. ambient temperature. Longer time for temperatures above 70-degrees F., and shorter time required when temperatures are below 70-degrees F. Average complete cycle range is about 12 to 17 minutes.

11. Let the machine function as shipped. Observe the first harvest of cubes. ADJUSTMENTS MAY BE REQUIRED.

# CM1400 START-UP

12. Observe second and third cube harvest.

## Check size of SCOTSMAN CONTOUR CUBE

Unlike other SCOTSMAN cubes which are made in a definite molded shape, contour cubes are produced in indentations and many shapes and sizes of contour cubes may be produced — only ONE size and shape combination is correct.

Charge Refrigeration System with **REFRIGERANT 502 ONLY.**

In areas where extreme problem water condition exists, filtering or purifying equipment is recommended. Contact SCOTSMAN ICE SYSTEMS, Service Department, Albert Lea, Minnesota 56007 for further details.

TOO LARGE

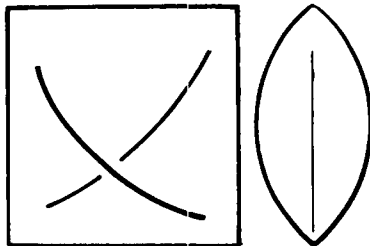

Too LARGE — may cause evaporator freeze ups. Adjust cube size control counter-clockwise to obtain smaller cubes

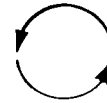

PROPER SIZE AND SHAPE

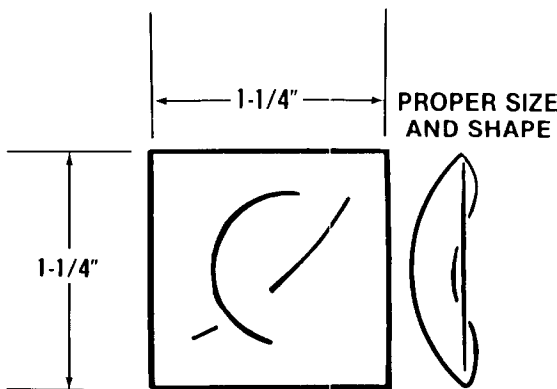

PROPER SIZE AND SHAPE of the contour cube. Icemaker operates at peak efficiency when a cube this size and shape is produced. A finely tuned system produces vertical strips of ice which easily break when they fall.

TOO SMALL

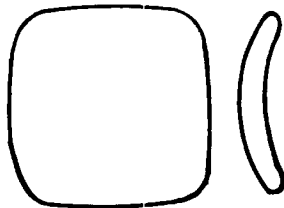

TOO SMALL. To obtain proper size cubes, adjust cube size control clockwise. May cause freeze up problems due to poor harvest.

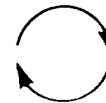

*Ice Cube Size & Shape*

# CM1400 START-UP

## ADJUSTMENT OF CUBE SIZE

To produce SMALLER sized ice cubes:

Locate cube size control knob in the front of the control box.

Rotate the adjusting screw one-eighth of a turn COUNTERCLOCKWISE to WARMER.

Observe size of the ice cubes in the next two ice cube harvests and adjust in one-eighth turn or less increments until desired ice cube is achieved.

To produce LARGER sized ice cubes:

Locate cube size control on the front of the control box.

Rotate the adjusting screw one-eighth of a turn CLOCKWISE to COLDER.

Observe size of ice cubes in the next two cube harvests and adjust in one-eighth turn or less increments until desired ice cube size is achieved.

Check texture of ice cubes; when partially cloudy throughout, suggests icemaker is operating short of water, or, possibly an extreme problem water condition exists where filtering or purifying equipment is recommended. Contact SCOTSMAN ICE SYSTEMS, Service Department, Albert Lea, Minnesota 56007 for further details. See SERVICE DIAGNOSIS chart for shortage of water symptoms and corrections.

**ROTATE ADJUSTMENT KNOB COUNTER-CLOCKWISE TO PRODUCE SMALLER CUBES**

**ROTATE ADJUSTMENT KNOB CLOCKWISE TO PRODUCE LARGER CUBES**

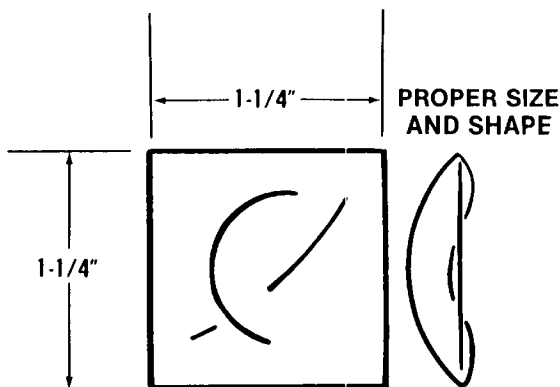

Check the Harvest time. The correct setting is one that allows enough time for all of the ice to fall from the evaporators and to fill the sump with water to the overflow point, plus 15-30 seconds extra time.

To adjust the timer:

- Disconnect electrical power supply to the icemaker.
- Loosen the screw on the timer that locks the two cams together.
- To decrease Harvest time, rotate the shaft of the timer counter-clockwise. To increase, turn the shaft clockwise.
- Retighten the screw to lock the two cams together again.
- Return power to icemaker. Check cube size and Harvest time.

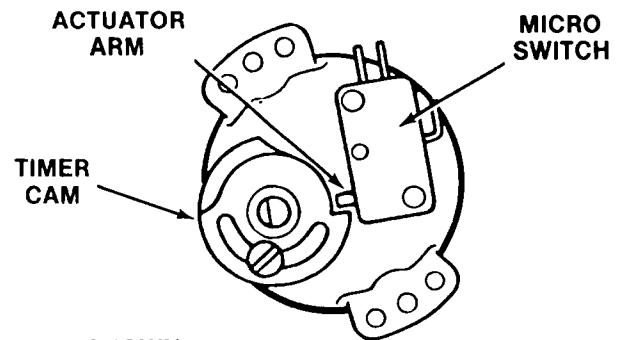

**CAM SHOWN AT BEGINNING OF HARVEST CYCLE**

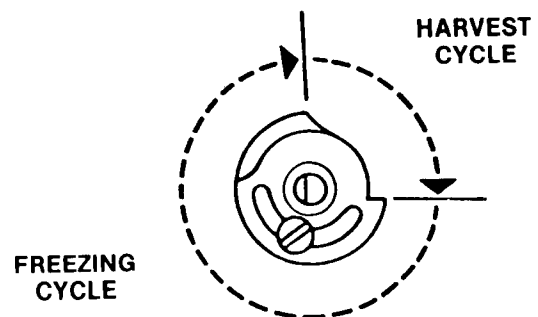

**CAM SHOWN DIVIDED INTO TYPICAL FREEZING & HARVEST CYCLES**

*Cube Size Control Adjustment*

# CM1400 START-UP

## BIN THERMOSTAT OPERATION

13. With the icemaker in the harvest cycle, hold ice against the bin thermostat control bulb to test shutoff which should cause the icemaker to shut OFF at the END OF THE HARVEST CYCLE.

Within minutes after the ice is removed from the sensing bulb, the bulb will warm up and cause the icemaker to restart. This control is factory set and should not be reset until testing is performed.

14. Replace control box cover and all cabinet panels and screws.

15. Thoroughly explain to the owner/user the significant specifications of the icemaker, start up and operation and go through the procedures in the operating instructions. Answer all questions about the icemaker by the owner and inform the owner of the name and telephone number of the authorized SCOTSMAN Distributor or service agency serving him.

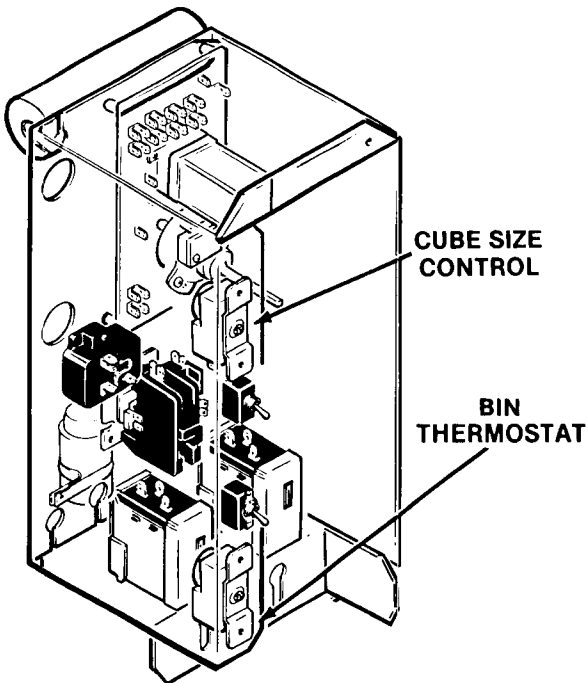



# CM1400 MAINTENANCE & CLEANING INSTRUCTIONS

## GENERAL

The periods and procedures for maintenance and cleaning are given as guides and are not to be construed as absolute or invariable. Cleaning especially will vary depending upon local water conditions and the ice volume produced and each icemaker must be maintained individually in accordance with its own particular location requirements.

## ICEMAKER

THE FOLLOWING MAINTENANCE SHOULD BE SCHEDULED AT LEAST TWO TIMES PER YEAR ON THIS ICEMAKER. CALL YOUR AUTHORIZED SCOTSMAN SERVICE AGENCY.

1. Check and clean or service any optional water treatment devices, if any installed.
2. Check the **CM1400** cabinet is level in the side-to-side and front-to-back directions.
3. Clean the water system, evaporator plates and sump assembly, using a solution of SCOTSMAN Ice Machine Cleaner. Refer to CLEANING

*Cleaning requirements vary according to local water conditions and individual user operation. Continuous check of the clarity of ice cubes and visual inspection of the water system parts, evaporator plates and the sump assembly before and after cleaning will indicate frequency and procedures to be followed in local areas.*

4. Check that each evaporator plate assembly is snug and secure on each wall support on the bin rear wall, in the holes of the front brace, and in each indent recessed in each arm of the sump assembly below the bottom corners of the evaporator plates.
5. Check and tighten all bolts and screws.
6. Check and tighten all electrical connections.
7. Check hot gas solenoid valve for correct operation.
8. With MASTER ON-OFF toggle switch and COMPRESSOR ON-OFF toggle switch in the OFF position, clean the condenser using vacuum cleaner, whisk broom or brush. Instruct customer to clean condenser frequently. DO NOT USE A WIRE BRUSH.
9. Check for water leaks and make corrections.
10. Check the bin thermostat control bulb to test shut off. Holding ice against bin thermostat control bulb should cause the icemaker to shut off at the end of the harvest cycle.

Within minutes after ice is removed from the bin thermostat control bulb, the icemaker will restart.

# CM1400 MAINTENANCE & CLEANING INSTRUCTIONS

## CLEANING - Icemaker

1. Remove screws and the front, and left side panels.
2. Check that both toggle switches on the control box are in the OFF position.
3. Rotate the shaft of the timer and switch assembly located in the control box **CLOCKWISE** until the actuator arm on the microswitch rides up out of the cam slot, to the outer surface of the cam, then stop. This is the start position for the freezing cycle. See **START Positions for the Freeze/Harvest Cycles**.
4. Position a container for catching drain water under the rubber plug at the bottom of the sump assembly.
5. Remove hose clamp, the rubber plug, and drain all water from the sump assembly into the container.

Replace rubber plug and hose clamp.

**WARNING**  
SCOTSMAN Ice Machine Cleaner contains Phosphoric and Hydroxyacetic acids. These compounds are corrosive and may cause burns. If swallowed, **DO NOT** induce vomiting. Give large amounts of water or milk. Call physician immediately. In case of external contact, flush with water. **KEEP OUT OF THE REACH OF CHILDREN.**

6. Prepare cleaning solution: Mix 24 ounces of SCOTSMAN Ice Machine Cleaner with two gallons of fresh, potable warm water. (95°F.-115°F.)
7. Carefully pour the cleaning solution into the sump assembly.
8. Immediately move the **MASTER ON-OFF** toggle switch on the control box to the **ON** position.
9. Allow the system to operate for about thirty minutes.

No ice cubes will be made because the **COMPRESSOR ON-OFF** toggle switch is off.

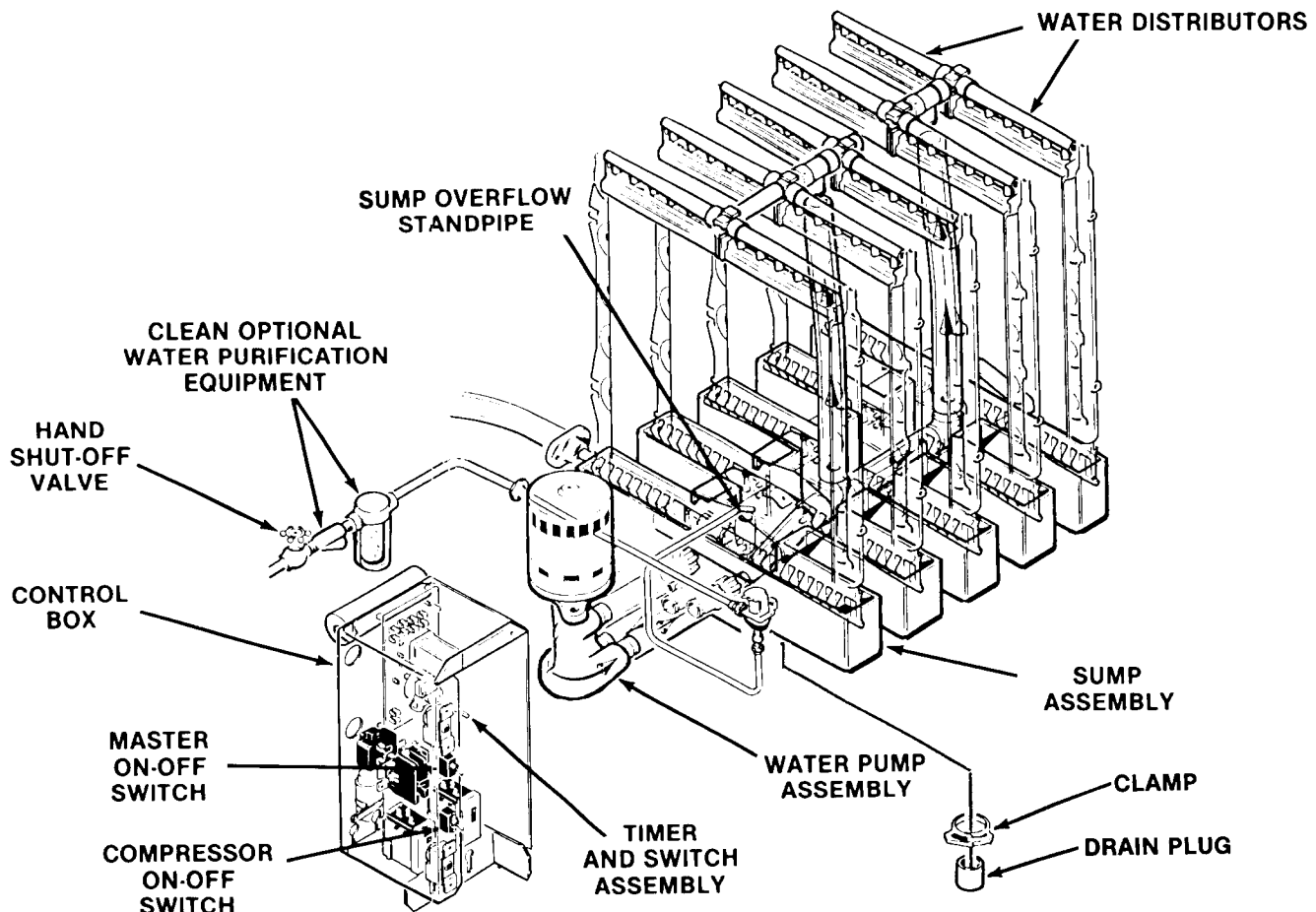

# CM1400 MAINTENANCE & CLEANING INSTRUCTIONS

10. Move the master ON-Off switch to the OFF position.

11. Remove the plug and drain the cleaning solution from the sump and rinse. Replace the drain plug, add two gallons of fresh water to sump. Restart the water pump and operate for 5 minutes, and then drain. Repeat this procedure two more times.

12. Rotate the shaft of the timer and switch assembly CLOCKWISE advancing through the freezing cycle to the harvest position (low part of the cam against microswitch). Move the master switch to the ON position to start the Harvest cycle. During each harvest cycle fresh water enters the water reservoir; diluting any leftover water, rinsing all water related parts, and washing away most mineral concentrations through the overflow drain.

If after completing the cleaning and flushing procedure, inspection of the water flow reveals that

one or more evaporator plates does not have a full flow of water for each vertical column of cubes, shut down the operation and remove and clean all water distributor manifolds. Reinstall the water distributor manifolds.

13. Move the compressor ON-OFF switch to the ON position to start the icemaking process.

////////////////////CAUTION////////////////////////////////////

**DO NOT use Ice produced from the cleaning solution. Be sure none remains in the bin.**

////////////////////////////////////

14. Check the next few ice cube harvests until the ice cubes are clear and the acid taste is gone.

15. Add hot water to the bin to melt the ice.

16. Replace all panels.

## ICE STORAGE BIN

The interior liner of the bin is in contact with a **food product: Ice**. The storage bin must be **cleaned** regularly to maintain a **sanitary** environment. Once a week cleaning with soap and water, a hot water rinse and an air dry is a **basic** procedure.

Scale that may form on the plastic liner can be removed by scrubbing the surface with a mixture of Scotsman Ice Machine Cleaner and hot water. Remove any scale prior to sanitizing.

////////////////////////////////////**WARNING**////////////////////////////////////

**Scotsman Ice Machine Cleaner contains Phosphoric and Hydroxyacetic acids. These compounds are corrosive and may cause burns. If swallowed, DO NOT induce vomiting. Give large amounts of water or milk. Call Physician immediately. In case of external contact, flush with water. KEEP OUT OF THE REACH OF CHILDREN.**

////////////////////////////////////

To Remove Scale:

1. Mix a cleaning solution of 4 ounces of Scotsman Ice Machine Cleaner to 4 pints of hot (95<sup>0</sup>F. to 110<sup>0</sup>F.) water.

2. Using rubber gloves, dip a nylon scouring pad into the cleaning solution, and scrub the scale off of the liner.

3. After all the scale has been removed, rinse all of the surfaces inside the bin with clean, hot water. Sanitize the bin interior.

Every 90 days, the interior should be sanitized with an approved commercial ice machine sanitizer, according to the directions of the sanitizer. Check with the local health department for sanitizer that meet local codes.

# CM1400 MAINTENANCE & CLEANING INSTRUCTIONS

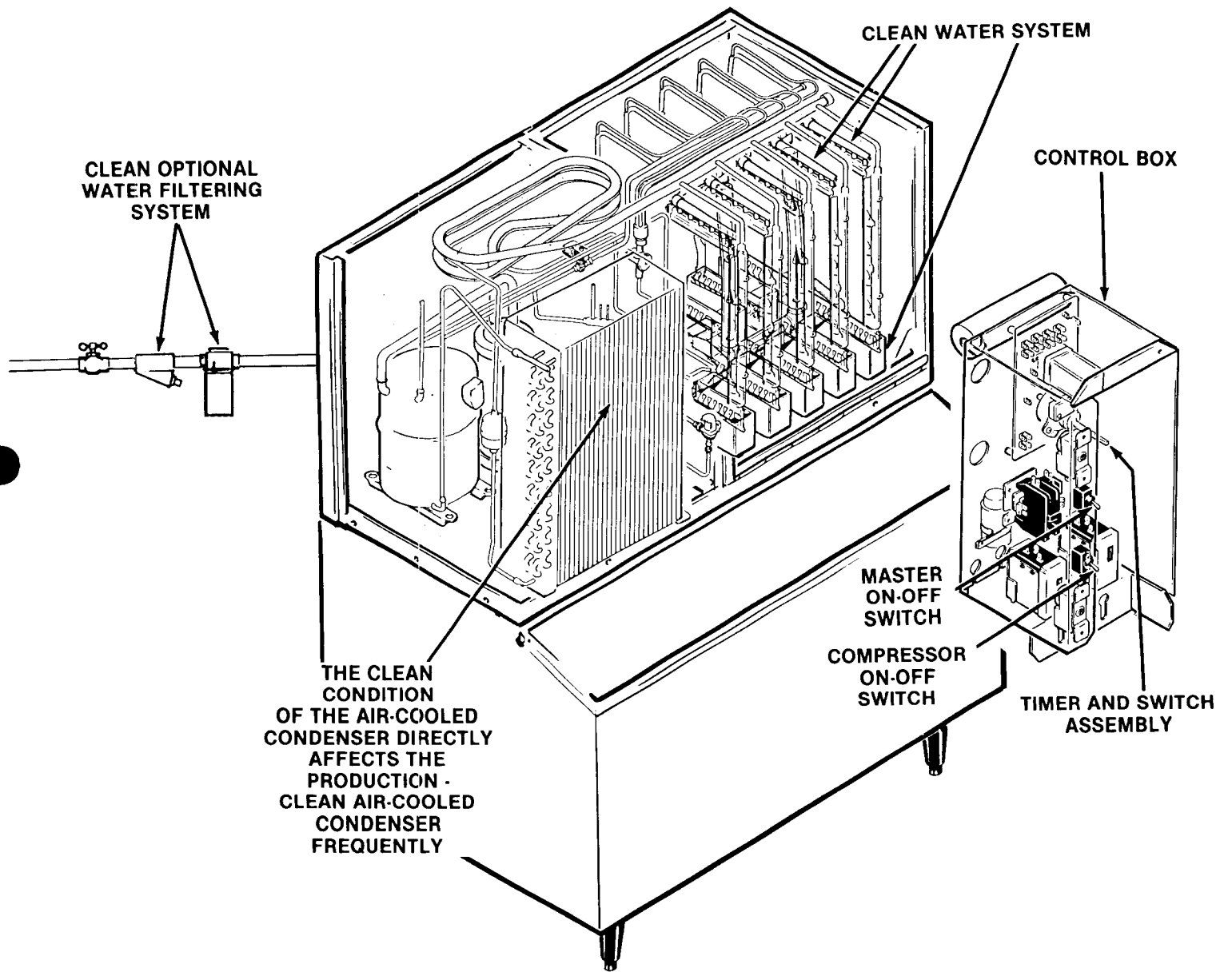

# CM1400 OPERATION

## OPERATION

### FREEZING CYCLE

Water from the sump assembly is pumped to the water distributor system at the top of each evaporator plate. From the water distributor the water cascades by gravity over all cells of the plate and to the sump assembly below for recirculation. At the beginning of the freezing cycle the electrical circuit is completed to the compressor and the water pump. The water pump operates continuously through both the freezing cycle and the harvest cycle.

In water-cooled models, water also flows through the condenser and out the drain. While in the condenser, water removes heat from the refrigerant and allows the refrigerant to condense from a gas to a liquid.

In the compressor, gaseous refrigerant is compressed and discharged into the condenser as a high pressure, high temperature gas. The refrigerant is cooled by either air or water and condenses into a high pressure, medium temperature liquid. This liquid refrigerant then passes through the thermostatic expansion valve where the temperature and pressure of the liquid refrigerant is lowered. From the TXV, the refrigerant moves through smaller diameter tubes and it next enters the evaporator plates. The refrigerant is warmed by the water cascading over the Evaporator plate and begins to boil off and become a gas. The refrigerant next

to boil off and become a gas. The refrigerant next travels through the accumulator and the heat exchange area of the suction line where any remaining liquid refrigerant boils off and returns to the compressor as a low pressure, low temperature gas, and the cycle starts again.

During the freezing cycle, the hot gas solenoid valve is CLOSED and the water inlet solenoid valve is CLOSED.

When the ice cubes are partially formed, the cube size control will sense the temperature at which it is preset to CLOSE. This will complete the electrical circuit to the timer. The timer then controls the remainder of the freezing cycle.

The timer will keep the icemaker operating in the freezing cycle for a selected length of time. This will give the ice cubes time to fully form. After that selected length of time, the timer will switch the icemaker into the harvest cycle through the contacts of the timer assembly microswitch.

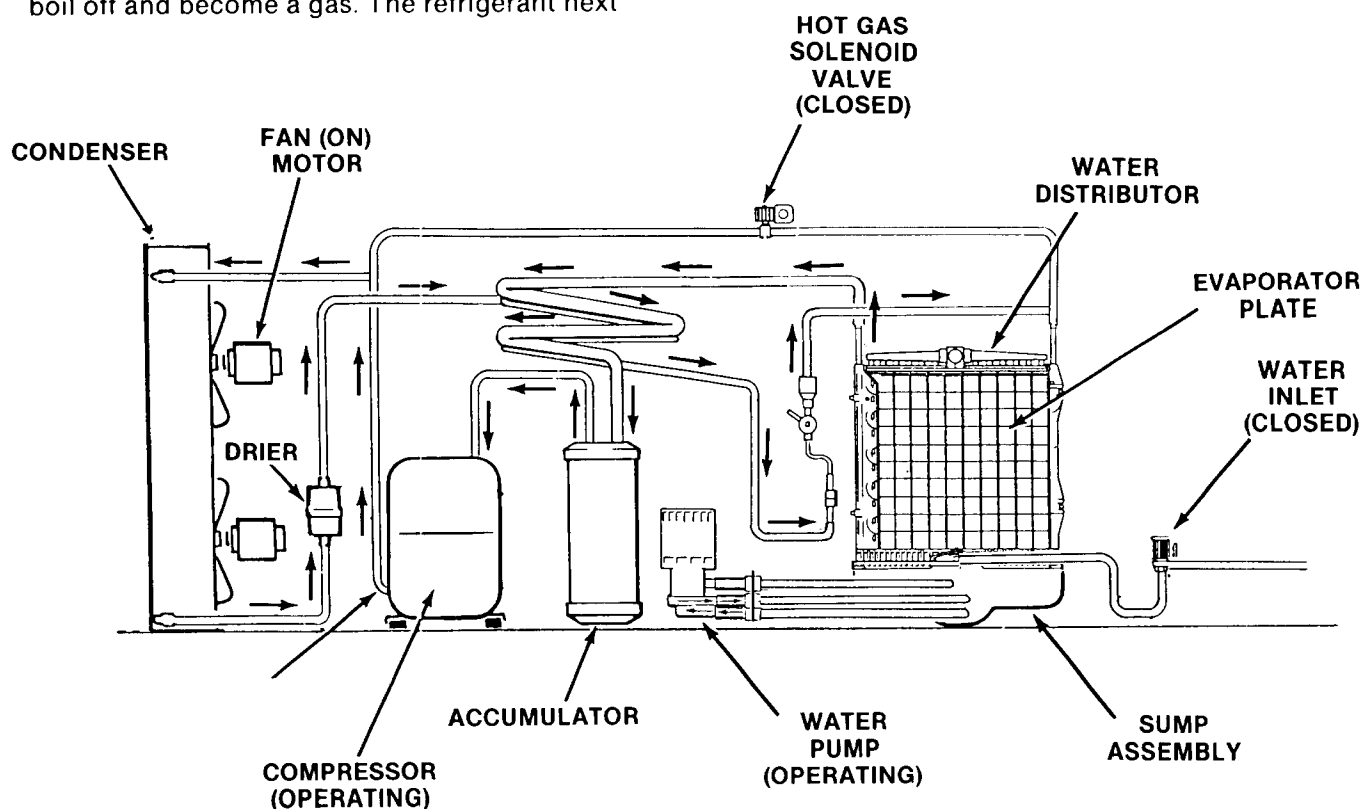

*Freezing Cycle*

# CM1400 OPERATION

## HARVEST CYCLE

When the timer switches the icemaker into the harvest cycle, high pressure, high temperature gas refrigerant being discharged from the compressor is diverted from the condenser through the hot gas solenoid valve into each evaporator plate. During this cycle, the gaseous refrigerant bypasses the condenser and the thermostatic expansion valve.

In the electrical circuit, both the compressor and the water pump are operating and the hot gas solenoid valve is energized and OPEN and the water inlet solenoid valve is OPEN.

The finished ice cubes are released from the sides of each evaporator plate, by the warming effect of

the hot gas flowing through each evaporator plate and the water cascading over the ice cubes. The released ice cubes drop into the ice storage bin below.

At the end of the harvest cycle, the timer cam will push the actuator arm of the microswitch IN. If the bin thermostat is still CLOSED, a whole new cycle will begin. If the bin thermostat is OPEN, the icemaker will shut OFF, at this time.

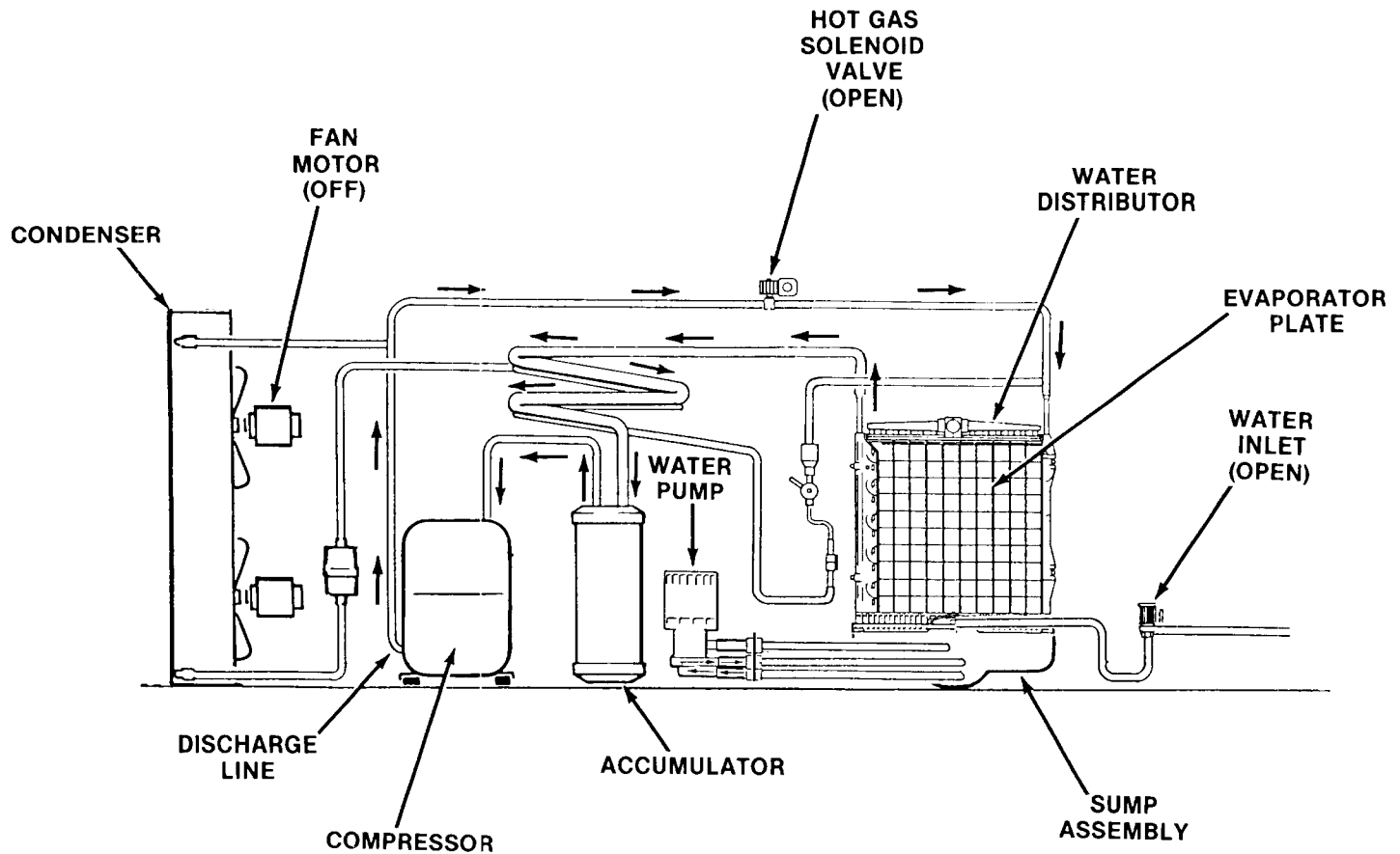

*Harvest Cycle*



# CM1400 OPERATION - ELECTRICAL SEQUENCE

The following charts illustrate which switches and which components are ON or OFF during a particular phase of the icemaking cycle.

Refer to the wiring diagram for a reference. Remember, the wiring diagram shows the unit as it is in the Timed Freeze Cycle.

## BEGINNING FREEZE

ELECTRICAL COMPONENTS (LOADS)	ON	OFF
Compressor	X	
*Fan Motor (Air-cooled only)	X	
Hot Gas Valve		X
Inlet Water Valve		X
P.C. Board Relay Coil	X	
Timer		X
Water Pump	X	

SWITCHES	ON	OFF
Bin Thermostat	X	
Cube Size Thermostat		X
H.P. Fan Control	X	
Toggle - Master	X	
Toggle - Compressor	X	
H.P. Control	X	
Timer Micro Switch N.C.		X
Timer Micro Switch N.O.	X	
High Temp Switch	X	

\*The fan control will open and close with changes in discharge pressure, but will usually be closed during early freeze, so the fan will usually be ON.

At the beginning of the freeze cycle, the timer is not turning, but the icemaker is refrigerating the water, starting to turn the water into ice.



# CM1400 OPERATION - ELECTRICAL SEQUENCE

## TIMED FREEZE

ELECTRICAL COMPONENTS (LOADS)	ON	OFF
Compressor	X	
*Fan Motors (Air-cooled only)	X	
Hot Gas Valve		X
Inlet Water Valve		X
P.C. Board Relay Coil	X	
Timer	X	
Water Pump	X	

SWITCHES	ON	OFF
Bin Thermostat	X	
Cube Size Thermostat	X	
H.P. Fan Control	X	X
Toggle Switch - Master	X	
Toggle Switch - Compressor	X	
H.P. Control	X	
Timer Micro Switch N.C.		X
Timer Micro Switch N.O.	X	
High Temp Switch	X	

After the icemaker has cooled the water and formed some ice on the evaporator, the evaporator will have gotten cold enough to have the cube size control close. All this does is start and run the timer.

\*The fan control will be opening and closing with the changes in discharge pressure, so the fan will be turning ON and OFF.

## HARVEST

ELECTRICAL COMPONENTS (LOADS)	ON	OFF
Compressor	X	
*Fan Motors (Air-cooled only)		X
Hot Gas Valve	X	
Inlet Water Valve	X	
P.C. Board Relay Coil		X
Timer	X	
Water Pump	X	

SWITCHES	ON	OFF
Bin Thermostat	X	
Cube Size Thermostat		X
H.P. Fan Control		X
Toggle Switch - Master	X	
Toggle Switch - Compressor	X	
H.P. Control	X	
Timer Micro Switch N.C.	X	
Timer Micro Switch N.O.		X
High Temp Switch	X	

The timer has now turned far enough so that the micro-switch plunger has dropped into the gap in the cam, this breaks the circuit to the relay in the P.C. Board - and that puts the machine into the Harvest cycle where the hot gas valve and inlet water valve have opened to harvest the ice. When ice is on the bin control, it will open and at the end of the harvest cycle shut off the machine.

\*The fan control will keep the fan OFF during the harvest cycle until the discharge pressure builds up to 190 PSIG, probably near the very end of the harvest cycle, then the fan will come ON.

# CM1400 SYSTEM SPECIFICATIONS

In servicing a machine, it is often useful to compare that individual units operating characteristics to those of a normally operating machine. The data that follows gives those characteristics, however, be aware that these values are for NEW, CLEAN machines. USE THESE NUMBERS AS A GUIDELINE ONLY.

## COMPONENT

Timer - 1 revolution of the cam, in minutes .....	8
Harvest Time, preset, in minutes .....	2-1/4
Inlet Water Valve, water flow in g.p.m. ....	1

	CI	CO
Cube Size Control, Reverse Acting, Temperature range (0°F. to +25°F.)	—	—
Bin Thermostat, Temperature Range	38.5°-43.5°	33.5°-38.5°
High Pressure Safety Switch, psig Air-cooled	Manual	450
High Pressure Safety Switch, psig Water-cooled	Manual	350
Fan Pressure Control, in psig	210	193

## OPERATING CHARACTERISTICS

On air-cooled models during the freezing cycle, the discharge pressure will slowly decline as the unit freezes ice and at the same time the suction pressure will also decline, reaching it's lowest point just before freeze. Compressor amps experience a similar drop.

On water-cooled, the discharge pressure is constant, maintained during the freeze cycle by the water regulating valve at 220 PSIG. However, suction pressure and compressor amps will still decline as the machine freezes ice.

### FREEZE CYCLE

Average Discharge Pressure A/C . . . . .	350-200 PSIG
Average Discharge Pressure W/C . . . . .	220 PSIG
Suction Pressure at the end of the Freeze Cycle . . . . .	20-40 PSIG
Cycle Time (Includes Harvest) . . . . .	12-30 Minutes

### HARVEST CYCLE

Average Discharge Pressure . . . . .	300-100 PSIG
Average Suction Pressure . . . . .	100-70 PSIG
Harvest Time, assumed to be	2-1/4 minutes.
This can be adjusted to suit local conditions.	

The values listed are representative of values seen at a wide range of air and water temperatures and are for a normal cube size.

When comparing these figures to field data, allow a variation from each end of the range given.

**TO SERVICE REFRIGERATION SYSTEM:  
TORQUE REFRIGERATION ACCESS VALVE  
CAPS TO 60-75 INCH POUNDS.**

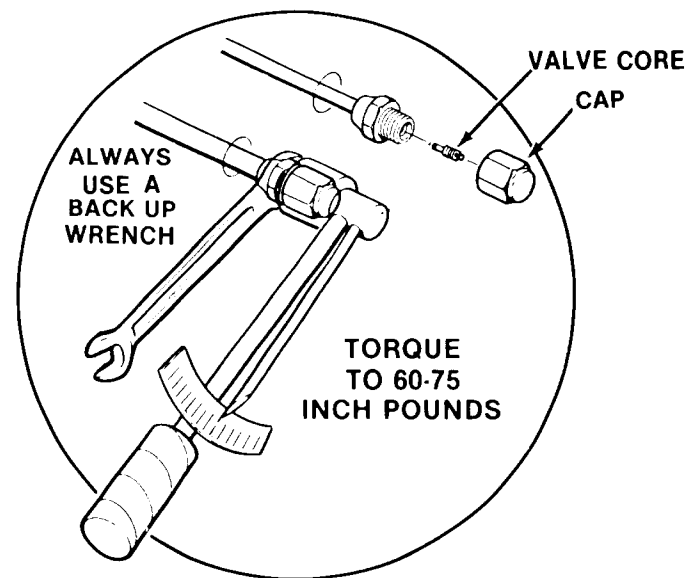

**ALWAYS USE A BACK-UP  
WRENCH TO AVOID DAMAGE  
TO THE REFRIGERANT TUBING.**

# CM1400 COMPONENT DESCRIPTION

## ① BIN THERMOSTAT CONTROL

The bin thermostat is located on the front edge of the control box with an accessible knob on the front. The sensing capillary tube is routed from the control out the side of the control box down and across the front edge of the sump and down into the bin thermostat bracket. The bin thermostat control functions to automatically shut OFF the icemaker when the ice storage bin is filled and ice contacts the capillary tube. It also signals the RESTART of the icemaker when the capillary tube starts to warm up after ice has been removed from the bin.

Bin thermostat control adjustment should ONLY be performed on icemakers installed in extreme warm or cold locations and adjust only in increments of one eighth turn at a time.

## ② COMPRESSOR CONTACTOR

The compressor contactor functions to carry the compressor line current. The contactor is wired so any control in the pilot circuit such as the bin thermostat, and high pressure controls, etc., will cause the contactor holding coil to be de-energized when the control contact OPENS, thereby, breaking the circuit to the compressor.

## ③ CUBE SIZE CONTROL

The temperature sensing cube size control affects the length of the freezing cycle prior to initiating the finishing timer. The cube size control closes its contacts when the evaporator reaches a preset temperature, starting the finishing timer. A variation in either ambient air or incoming water temperature will affect the efficiency of the refrigeration system. This will vary the length of time it takes the evaporator to reach the temperature at which the cube size control is preset to CLOSE which, in turn, will affect the overall cycle time.

See *Cube Size Adjustment* BEFORE attempting to adjust the control.

## ④ FINISH RELAY

The multi-function, three pole, double-throw, plug-in relay is installed directly into a receptacle on the printed circuit board in the control box. The relay functions, in part, to by-pass the bin thermostat control to prevent the icemaker from shutting OFF when a filled-bin condition occurs during the freezing cycle. The by-pass action serves to ensure full-sized ice cubes with each harvest cycle and to prevent short cycling on the bin thermostat control.

## ⑤ FINISHING TIMER — Timer & Switch Assembly.

The function of the finishing timer begins when activated by the cube size control. The outer surface, or large diameter lobe of the timer cam, determines the timer cycle for finish freezing of the ice cubes while the inner surface or small diameter lobe determines the time cycle for the harvest sequence. All electrical circuitry is connected through the printed circuit board and the finishing timer and shunted by the single-pole, double-throw microswitch to either the freezing cycle or the harvest cycle. The microswitch is actuated by a cam assembly directly connected to the timer motor. The timer cam can be adjusted to vary the defrost line, as required. One complete rotation of the cam will take eight minutes. Harvest is preset at two and one-fourth minutes.

## ⑥ HOT GAS SOLENOID VALVE

The hot gas solenoid valve functions only during the harvest cycle, to divert the hot discharge gas from the compressor, bypassing the condenser and capillary tube, for direct flow in the evaporator plates to release ice cubes from the ice cube molds. The hot gas solenoid valve is comprised of two parts, the body & plunger and the coil & frame assemblies. Installed in the discharge line of the compressor, the energized solenoid coil lifts the valve stem within the valve body, to cause the hot discharge gas to be diverted when the finishing timer has advanced to the start of the harvest cycle.

# CM1400 COMPONENT DESCRIPTION

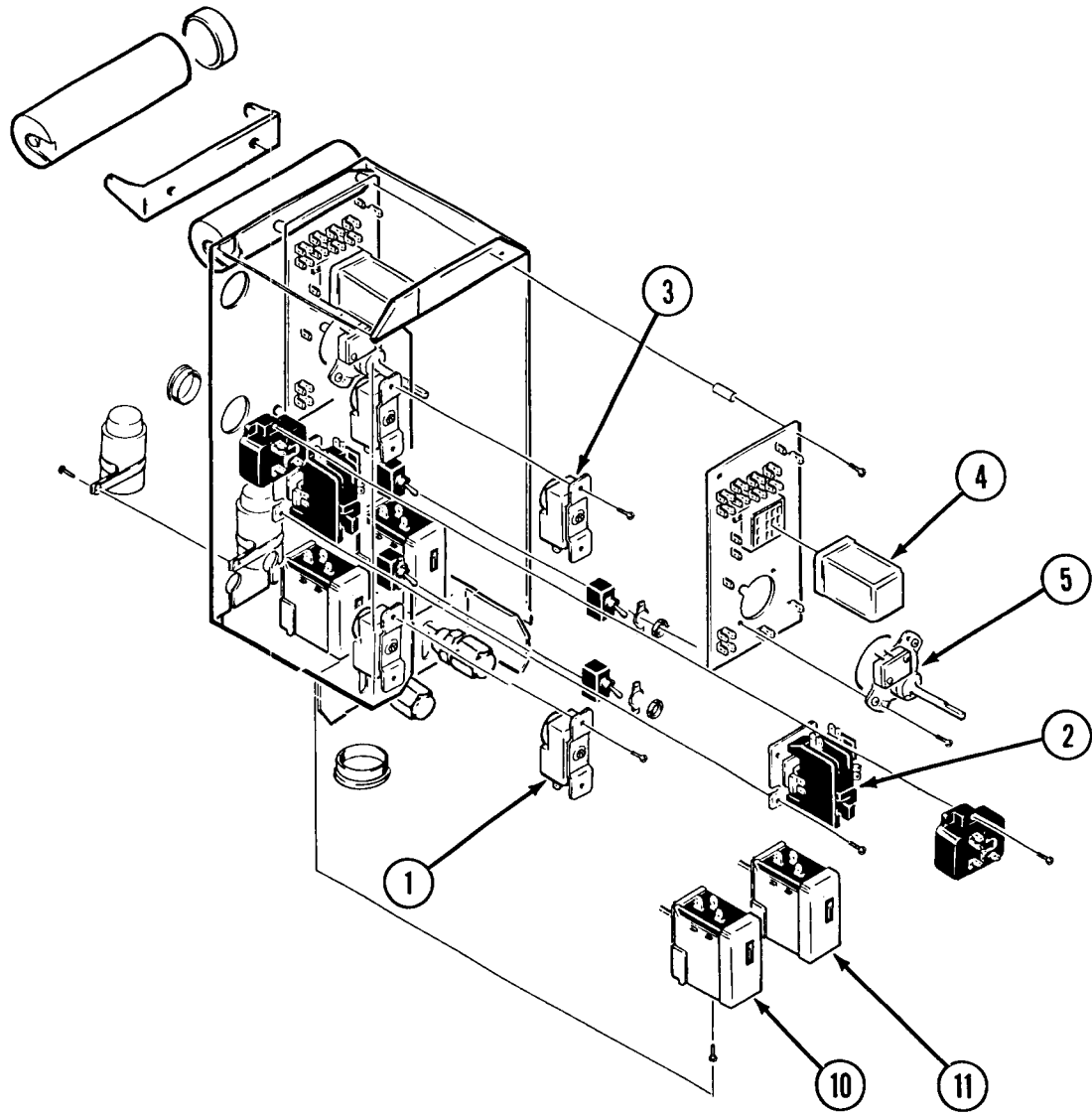

# CM1400 COMPONENT DESCRIPTION

## 7 WATER INLET SOLENOID VALVE

The water inlet solenoid valve functions to fill the sump assembly with water and overflow out the overflow standpipe located at the bottom of the sump. This action rinses the sump at the end of each harvest cycle. The flow rate is 1.0 g.p.m.

## 8 WATER REGULATOR VALVE -- Water-Cooled Model

The water regulator valve functions to maintain a constant compressor head pressure, by regulating the amount of inlet water flow through the condenser on water-cooled models. The valve operates through the refrigerant system high side pressure. Rotating the adjusting screw, located on top of the valve, can INCREASE or DECREASE the water flow through the water-cooled condenser, which in turn, will DECREASE or INCREASE the compressor operating head pressure. It is to be set at 220 PSIG.

When installing a replacement water regulator valve, be sure the replacement valve is installed with the arrow positioned in the direction of the water flow.

## 9 WATER DISTRIBUTION SYSTEM

The water distribution system functions to evenly supply water to all cells of the evaporator plates. The water pump pumps water from the sump up the vertical tygon tube to the tee. From there water

is channeled through the water manifold to the water distributors, above each evaporator plate, and from six holes within each distributor, water flows to the cells of each side of the evaporator plates. Gravity flow returns the unfrozen excess portion of water to the sump reservoir for recirculation.

Always CHECK NAMEPLATE on individual icemaker for specific refrigerant charge, BEFORE charging the refrigeration system.

## 10 FAN PRESSURE CONTROL -- Air-Cooled Models only.

The fan pressure control functions to maintain a minimum discharge pressure by cycling the fan on and off. The approximate C.I. is 210 PSIG and C.O. is 193 PSIG.

## 11 HIGH PRESSURE SAFETY CONTROL

This is a manual reset control that shuts down the icemaker, should the discharge pressure ever reach 450 PSIG on air-cooled and 350 PSIG on water-cooled.

## 12 THERMOSTATIC EXPANSION VALVE (TXV)(FBRE 1-1/2)

The thermostatic expansion valve regulates the flow of refrigerant to the evaporator and reduces pressure of liquid refrigerant from condensing pressure to evaporating pressure.

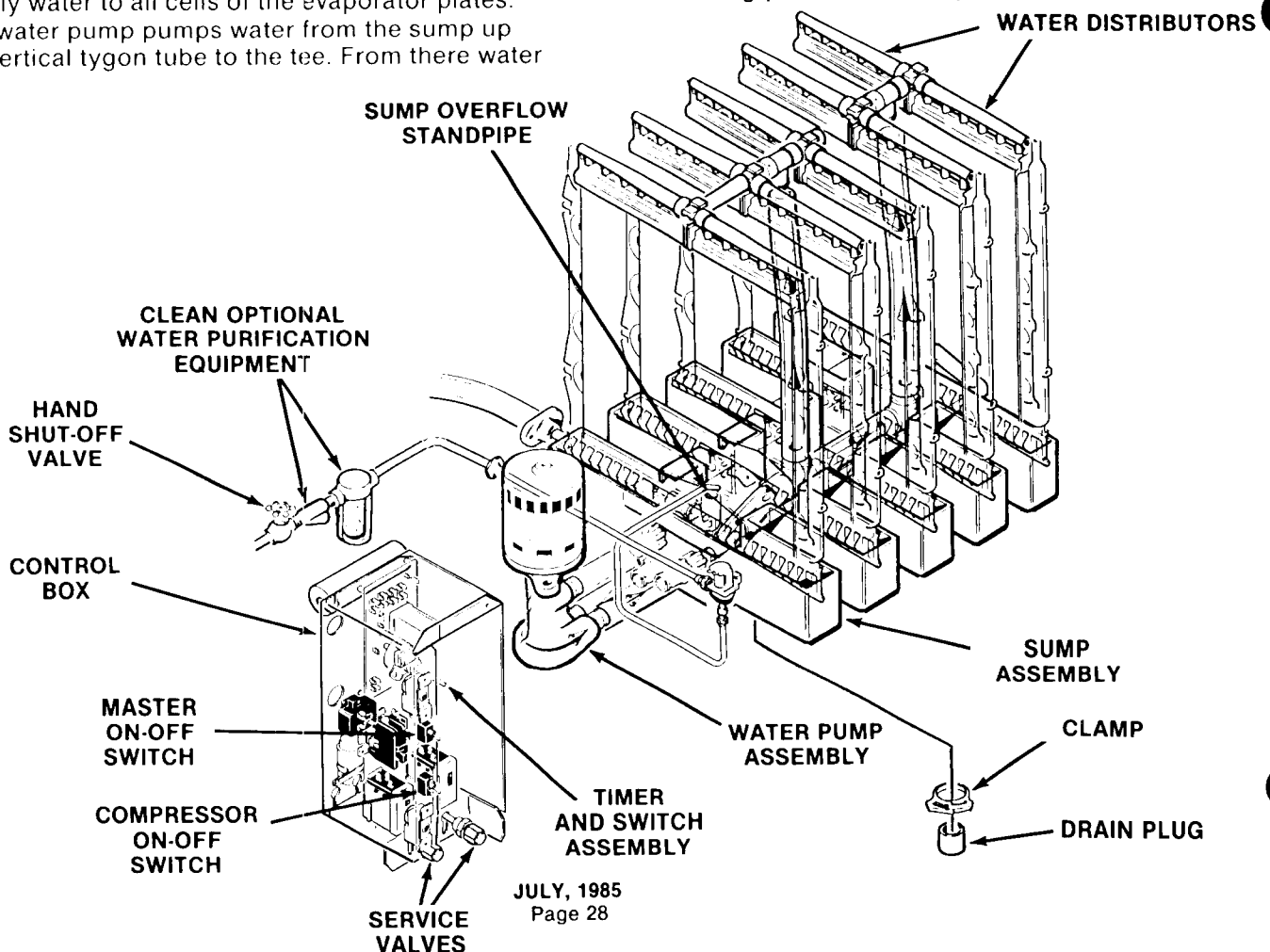

**WATER-COOLED  
REFRIGERATION  
SYSTEM**

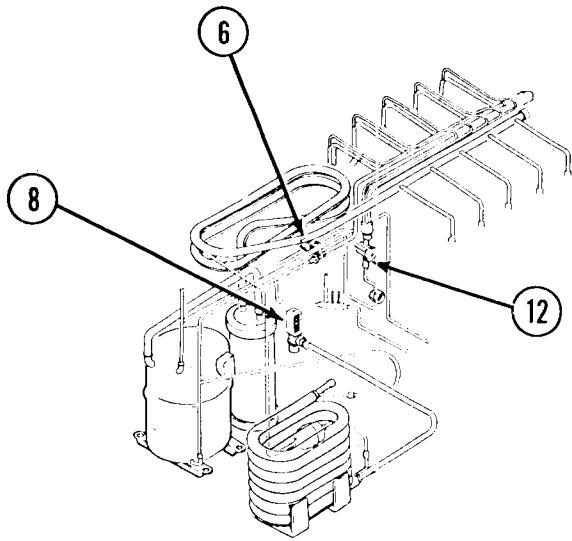

**AIR-COOLED  
REFRIGERATION  
SYSTEM**

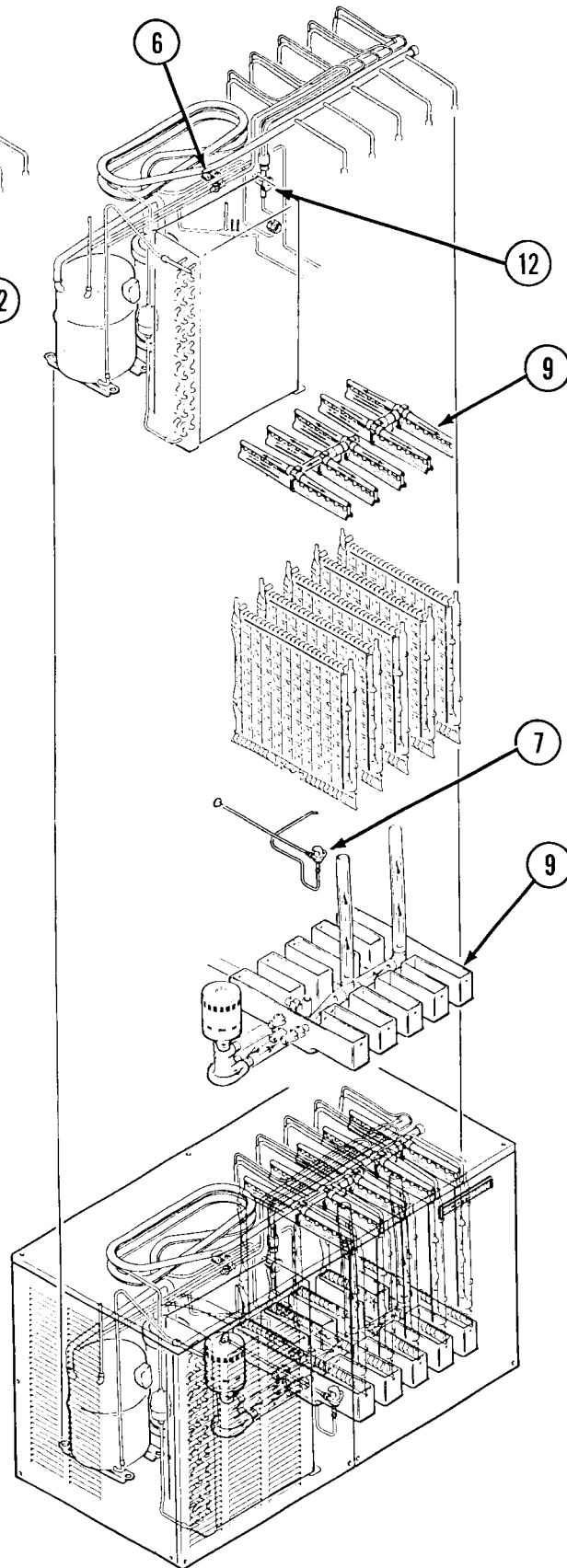

# CM1400 SERVICE DIAGNOSIS

The service diagnosis section is for use in aiding the serviceman in diagnosing a particular problem for pin-pointing the area in which the problem lies, thus, an ever available reference for proper corrective action.

The following chart lists corrective actions for the causes of known symptoms of certain problems that can occur in the icemaking-refrigeration system.

## ICEMAKING - REFRIGERATION SYSTEM

SYMPTOM	POSSIBLE CAUSE	CORRECTION
Irregular size cubes some cloudy.	Some distributor holes plugged.	Clean distributor holes. Clean water sump.
	Shortage of water.	See Shortage of water CORRECTION.
	Unit not level.	Level cabinet, as required.
Cubes too large.	Dirty air-cooled condenser.	Clean condenser.
	Cube Size Control set too cold.	Rotate Cube Size Control dial toward WARMER.
Cubes too small.	Cube Size Control set too warm.	Rotate Cube Size Control dial toward COLDER.
	Partially restricted capillary tube. (Kinked, pinched off, etc.)	Replace Heat Exch. Assy.
	Moisture in refrigeration system.	Blow refrigerant charge; replace drier; evacuate system; add proper refrigerant charge.
	Shortage of water.	See Shortage of water CORRECTION.
Cloudy Cubes.	Shortage of water.	See Shortage of water SYMPTOM.
	Dirty water supply.	Check water quality and install water purification system.
	Accumulated impurities.	Use SCOTSMAN Ice Machine Cleaner and clean icemaker.
Shortage of water.	Short Harvest Cycle.	Adjust cam of timer and switch assembly.
	Water leak in sump area or off evaporator plate.	Locate Leak and correct condition.
	Partial restrictions in water inlet strainer.	Clean or replace strainer.
	Water pressure too low.	Check for 20 PSI flowing water. Restore pressure.

# CM1400 SERVICE DIAGNOSIS

SYMPTOM	POSSIBLE CAUSE	CORRECTION
Decreased Ice capacity.	High head pressure, result of dirty Condenser or faulty Fan Motor or faulty Fan Control.	Clean Condenser. Repair or replace Fan Motor or Controls.
	Non-condensable gas in the system.	Purge the system, evacuate and recharge per nameplate requirements.
	Poor air circulation or extreme hot location.	Relocate the cabinet; or provide ventilation.
	Overcharge of refrigerant. Inlet water or hot gas solenoid valve leaking.	Evacuate and recharge per name plate. Replace valve.
	Partially restricted capillary tube. Defective Compressor.	See Cubes Too Small CORRECTION. Replace Compressor.
Poor harvests. Icemaker does not harvest.	Too short defrost time.	Check and adjust harvest cycle.
	Restriction in water inlet line.	Check strainer and flow check valve.
	Hot gas solenoid does not open. Binds or burned out.	Replace solenoid, coil or valve as applicable.
	Undercharge of refrigerant.	Charge to nameplate requirements.
	Water pressure too low.	Check for 20 PSI flowing water. Restore pressure.
	Cube size too large or too small.	Adjust size with cube size control.
Compressor cycles intermittently.	Low voltage.	Check for circuit overload. Check building supply voltage, if low, contact power company.
	Dirty Condenser.	Clean Condenser with vacuum cleaner or brush. DO NOT USE A WIRE BRUSH.
	Air circulation blocked.	Locate cabinet with adequate air space for proper air flow.
	Defective Fan Motor.	Replace Fan Motor.
	Non-condensable gases in system.	Purge the system and recharge per nameplate requirements.
Icemaker will not operate.	Blown fuse in line.	Replace fuse and check for cause.
	Master switch in OFF position.	Set switch to ON position.
	Faulty Master switch.	Replace switch.
	Timer contacts open.	Replace Timer microswitch.
	Faulty Bin Thermo. Hi Temp Switch open.	Replace. Determine why hot gas line is too hot.



# CM1400

## REMOVAL AND REPLACEMENT PROCEDURES

### ADJUSTMENT OF THE CUBE SIZE CONTROL

#### CAUTION

BEFORE performing actual adjustment to the cube size control, check other possible causes for cube size problems. Refer to SERVICE DIAGNOSIS for problem review and analysis. DO NOT perform adjustment when a new cube size control is installed until the control bulb has been properly installed in the tube well on the evaporator outlet tube and the icemaker has progressed through several complete freezing and harvest cycles, to observe size and quality of ice cubes freezing and harvest cycles, and whether or not a cube size problem exists.



As a reverse acting temperature control, adjustment on the cube size control is performed to cause either larger sized ice cubes or smaller sized ice cubes to be produced.

To produce LARGER sized ice cubes:

1. Locate the cube size control on the front of the control box.
2. Rotate the adjusting knob one-eighth of a turn CLOCKWISE toward COLDER.
3. Observe size of ice cubes in next two ice cube harvests and repeat step 2 above, in one-eighth turn increments, until desired ice cube size is achieved.

To produce SMALLER sized ice cubes:

1. Locate the cube size control on the front of the control box.
2. Rotate the adjusting knob one-eighth of a turn COUNTERCLOCKWISE toward warmer.
3. Observe size of ice cubes in next two ice cube harvests and adjust in one-eighth turn increments, until desired ice cube size is achieved.

### ADJUSTMENT OF THE TIMER & SWITCH ASSEMBLY

The timer and switch assembly is factory set, so one complete revolution of the cam on the timer represents eight minutes. Five and one-half minutes comprise the freezing cycle event during cam rotation and the final two and one-half minutes program the defrost and harvest cycle. Rotating the shaft of the timer cam CLOCKWISE will allow positioning the actuator arm of the microswitch on the cam at the selected start position for either the freezing cycle or harvest cycle, as required in the cleaning instructions.

#### WARNING

Disconnect electrical power supply to icemaker whenever adjustment procedures are performed.



To adjust the timer & switch assembly:

- A. HARVEST CYCLE: Slowly rotate the shaft of the timer and switch assembly located in the control box CLOCKWISE until the actuator arm on the microswitch initiates the harvest cycle. An audible click can be heard but in a noisy area, look at the cam and switch to observe the event.
- B. FREEZING CYCLE: Slowly rotate the shaft of the timer and switch assembly located in the control box, CLOCKWISE, until the actuator arm on the microswitch initiates the freezing cycle.
- C. The length of the harvest cycle can be changed by loosening the adjustment screw on the cam. The minimum harvest setting is two minutes; the normal setting is two and one-half minutes, as set at the factory. It is important that the length of the harvest cycle allow enough time for all the ice cubes to fall from the evaporator. Too short of a time will cause the evaporator to freeze up and stop ejecting ice into the bin. Too much time wastes icemaking capacity, energy and water. Adjustment of the harvest cycle may require a corresponding adjustment of the cube size control.

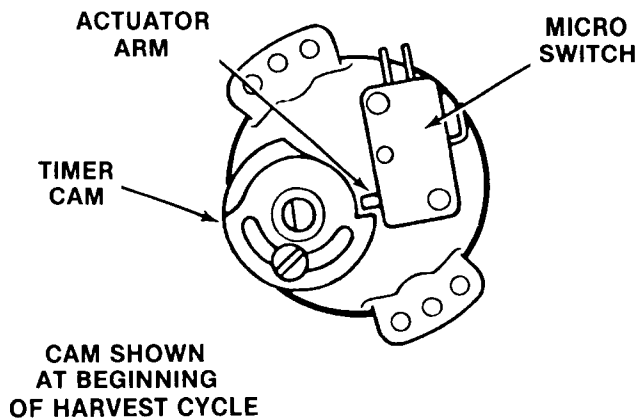

CAM SHOWN AT BEGINNING OF HARVEST CYCLE

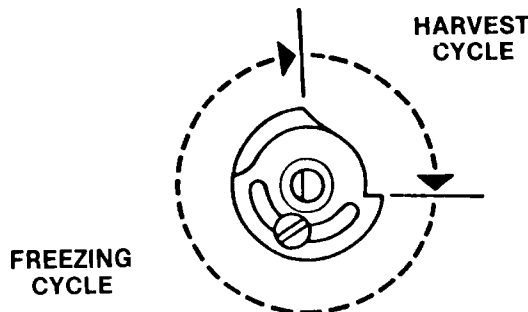

CAM SHOWN DIVIDED INTO TYPICAL FREEZING & HARVEST CYCLES

# CM1400 REMOVAL AND REPLACEMENT PROCEDURES

## ////////////////////// WARNING ////////////////////////

Be sure the electrical power supply circuit breaker and the inlet water supply are OFF, BEFORE starting any of the following REMOVAL AND REPLACEMENT procedures as a precaution to prevent possible personal injury or damage to equipment.

////////////////////////////////////

### ADJUSTMENT OF THE WATER REGULATOR ASSEMBLY — WATER-COOLED MODELS

The correct compressor head pressure on water-cooled models is 220 PSIG. Adjusting the water regulator valve increases or decreases the rate of flow of water, through the water-cooled condenser; which increases or decreases the affected temperature/pressure of the compressor head pressure, INCREASED water flow, results in DECREASED or LOWER head pressure; while, DECREASED water flow, results in INCREASED or HIGHER head pressure.

To adjust the water regulator assembly:

To INCREASE the head pressure: Rotate the adjusting screw COUNTERCLOCKWISE.

To DECREASE the head pressure: Rotate the adjusting screw CLOCKWISE.

Check change in compressor head pressure, and repeat adjustment as necessary, to achieve desired operating head pressure.

### REMOVAL AND REPLACEMENT OF THE BIN THERMOSTAT CONTROL

To remove the bin thermostat control:

1. Remove screws and remove the front panel.
2. Remove screws and the control box cover.
3. Remove the bin thermostat capillary tube from the bin thermostat bracket.
4. Remove screws and the bin thermostat control.
5. Remove electrical leads.

To replace the bin thermostat control, reverse the removal procedure.

### REMOVAL AND REPLACEMENT OF THE COMPRESSOR ASSEMBLY

To remove the compressor assembly:

1. Remove screws and remove the front panel.
2. Remove screws and remove left side panel.
3. Bleed off or blow the refrigerant charge through the Schrader valve.
4. Remove the cover from the terminal box on the compressor, then, remove electrical leads from the compressor.
5. Unsolder suction, discharge and process header from compressor.
6. Remove four bolts and washers which secure the compressor to the chassis mounting base.
7. Remove the compressor from the cabinet.

Always install a replacement drier anytime the sealed refrigeration system is opened. Do not replace the drier until all other repair or replacement has been completed.

### REMOVAL AND REPLACEMENT OF THE CONDENSER — AIR-COOLED MODELS

To remove the condenser:

1. Remove screws and remove the front panel.
2. Remove screws and remove cabinet top and left side panels.
3. Bleed off or blow the refrigerant charge through the Schrader valve.
4. Unsolder and disconnect refrigerant lines from the condenser.
5. Unsolder and remove the drier from the refrigerant lines connecting to the condenser.
6. Remove screws, lockwashers and the condenser from the chassis base.

Always install a replacement drier, anytime the sealed refrigeration system is opened. Do not replace the drier until all other repair or replacement has been completed.

To replace the air-cooled condenser, reverse the removal procedure.

# REMOVAL AND REPLACEMENT PROCEDURES

## REMOVAL AND REPLACEMENT OF THE CONDENSER — WATER-COOLED MODELS

To remove the condenser:

1. Remove screws and the left front panel.
2. Bleed off or blow the refrigerant charge through the Schrader valve.
3. Check to be sure building source water inlet supply shutoff valve to rear of chassis is OFF.
4. Disconnect water-cooled condenser inlet water line at the water regulator assembly outlet fitting.
5. Unsolder the refrigerant capillary tube distributor line at the outlet end of the drier, the refrigerant outlet line from the bottom of the condenser, and remove the drier from the lines.
6. Unsolder the compressor discharge line, at the top of the water-cooled condenser.
7. Unsolder the condenser water outlet line, at the top of the water-cooled condenser.
8. Remove two screws and washers and the water-cooled condenser from the cabinet.

Always install a replacement drier, anytime the sealed refrigeration system is opened. Do not replace the drier until all other repair or replacement has been completed.

To replace the water-cooled condenser, reverse the removal procedures.

## REMOVAL AND REPLACEMENT OF THE CUBE SIZE CONTROL

To remove the cube size control:

1. Remove screws and remove the left front panel.
2. Remove screws and control box cover.
3. Remove the coiled capillary tube bulb from sensing well on the evaporator outlet line.
4. Remove electrical leads from the cube size control.
5. Remove screws and the cube size control.

To replace the cube size control, reverse the removal procedure.

## REMOVAL AND REPLACEMENT OF THE DRIER

To remove the drier:

1. Remove screws and remove the front panel.
2. Bleed off or blow the refrigerant charge through the Schrader valve.
3. Unsolder refrigeration lines at both ends of the drier and remove the drier.

Always install a replacement drier anytime the sealed refrigeration system is opened. Do not replace the drier until all other repair or replacement has been completed.

To replace the drier:

### //////////////////// CAUTION //////////////////////

**If the factory seal is broken on the replacement drier exposing it to the atmosphere more than a few minutes, the drier will absorb moisture from the atmosphere and lose substantial ability for moisture removal.**

**Be sure the replacement drier is installed with the arrow positioned in the direction of the refrigerant flow.**

### ////////////////////////////////////

1. Remove the factory seals from the replacement drier and install the drier in the refrigerant lines with the arrow positioned in the direction of the refrigerant flow.
2. Solder the drier into the lines, two places, taking precautions to NOT OVERHEAT the drier body during installation soldering.
3. Purge the system and check for leaks.
4. Thoroughly evacuate the system to remove moisture and non-condensables.
5. Charge the system with refrigerant by weight. SEE NAMEPLATE.
6. Replace and attach the left side panel.

# CM1400 REMOVAL AND REPLACEMENT PROCEDURES

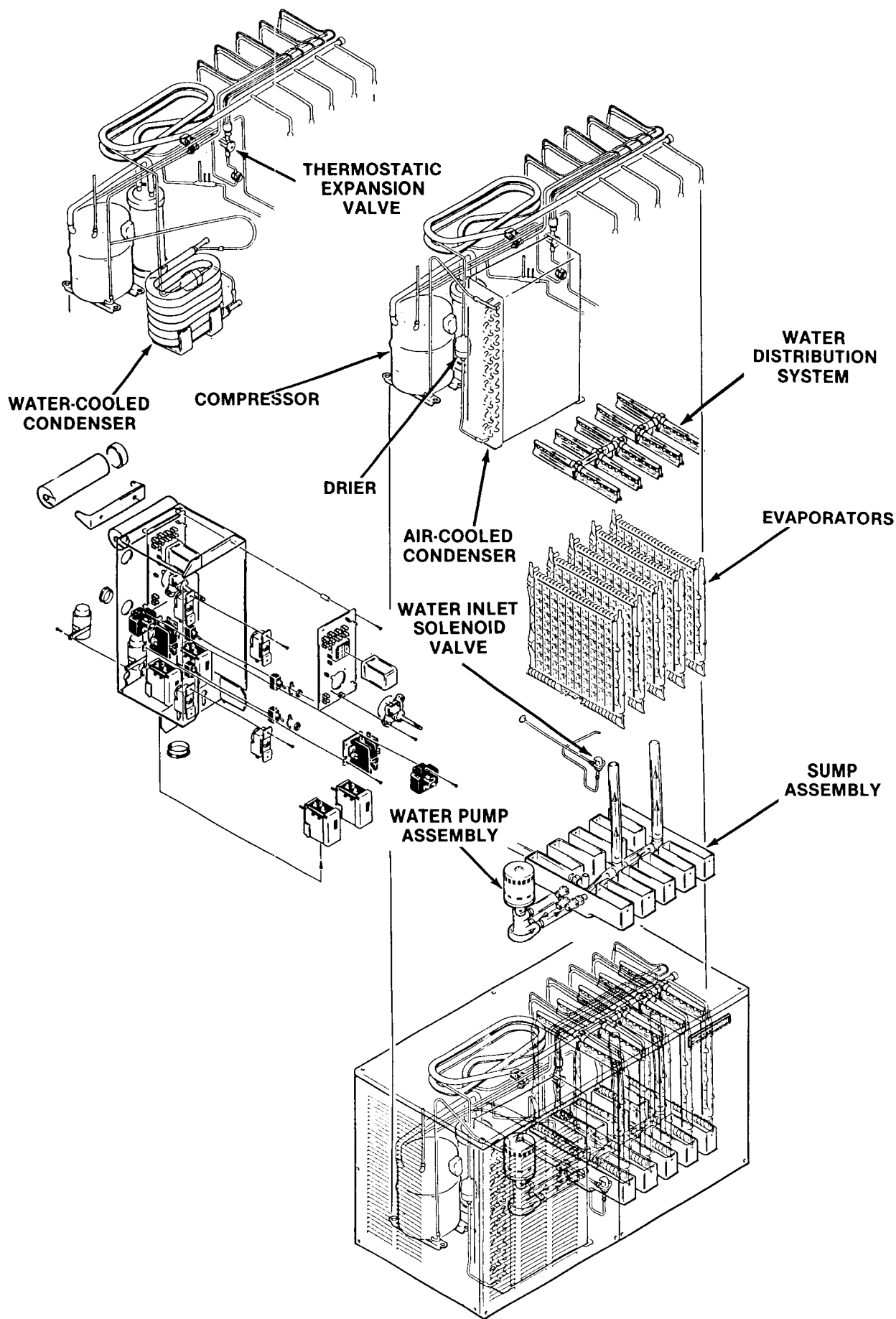

# CM1400 REMOVAL AND REPLACEMENT PROCEDURES

## REMOVAL AND REPLACEMENT OF THE EVAPORATOR PLATE ASSEMBLY

To remove the evaporator plate:

1. Remove screws and remove the front right panel.
2. Remove screws and remove cabinet top panel.
3. Remove screws and remove front braces from the cabinet assembly.
4. Bleed off or blow the refrigerant charge through the Schrader valve.
5. Unsnap from the evaporator and remove reservoir.
6. Disconnect Tygon water inlet tubes at the water manifold tees above the evaporator plates.
7. Slide the water distributor tube on the left about 1/8-inch along the top of the evaporator plate until the water distributor tube can be unsnapped from the flexible notch.

### CAUTION

Use EXTRA PRECAUTION to protect the plastic parts during the next step to unsolder the refrigerant lines, two places, at the top of the evaporator plate. Position wet cloths over top of plates, as well as over the plastic liner at the rear, to prevent accidental head damage or possible fire from torch flame.

8. Unsolder and remove the refrigerant lines at the top of the evaporator plate.
9. Remove screws attaching the evaporator plate support to the cabinet and remove the evaporator plate.
10. Remove screws and remove sump covers.

Always install a replacement drier anytime the sealed refrigeration system is opened. Do not replace the Drier until all other repair or replacement has been completed.

To replace the Evaporator Plate, reverse the removal procedure.

## REMOVAL AND REPLACEMENT OF THE FAN MOTOR — AIR-COOLED MODELS

### WARNING

Disconnect electrical power supply to icemaker whenever adjustment procedures are performed.

To remove the fan motor assembly:

1. Remove screws and remove the front panel.
2. Remove screws and remove cabinet left panel.
3. Disconnect the two electrical leads, from the fan motor, at the control box assembly.

Before next step, measure to make accurate mental note of the distance the fan blades extend beyond the fan shroud, so during replacement the correct distance is maintained.

4. Remove screws and the fan motor and bracket assembly; and remove the fan motor and bracket from the chassis base.
5. Loosen set screws on the fan blade and remove the fan blade from the fan motor. Mark or note position of the blade on the shaft of the fan motor, for replacement.
6. Remove screws and lockwashers and separate the fan motor from the fan motor bracket.

To replace the fan motor assembly, reverse the removal procedure.

Be sure to replace the fan blade with the hub of the fan blade facing the fan motor, to ensure air flow is toward the fan motor; and, is set at marked location on shaft and setscrews tightened on the FLAT part of the shaft of the fan motor.

## REMOVAL AND REPLACEMENT OF THE INLET WATER SOLENOID VALVE ASSEMBLY

To remove the inlet water valve assembly:

1. Shut OFF water supply to machine.
2. Remove screws and remove front left panel.
3. Remove screws and pull the water solenoid valve out to gain access.
4. Loosen and remove inlet water line fitting from the inlet water solenoid valve assembly.
5. Remove inlet water Tygon tubing from the water solenoid valve.

To replace the inlet water valve assembly, reverse the removal procedure.

# CM1400 REMOVAL AND REPLACEMENT PROCEDURES

## REMOVAL AND REPLACEMENT OF THE WATER DISTRIBUTOR TUBES AND MANIFOLD TUBES

To remove the water distributor tube and manifold tube:

1. Remove screws and remove the front right panel.
2. Slide the water distributor tube to the rear about 1/8-inch along the top of the evaporator plate until the water distributor tube can be unsnapped from the flexible notch and lifted upward at the right side.
3. Unsnap and disconnect water distributor tubes from the water manifold section.
4. To replace the water distributor tubes and manifold tubes, reverse the removal procedure. BE SURE the notches in the water manifold tubes properly engage the alignment keys in the tee.

BE SURE the water distributor tube is securely fastened at the notch at both sides of the evaporator plate.

Check identical attachment for the left water distributor tube and notch, also, that the distributor/manifold connections at the top

center of each evaporator plate is snug against the top of the plate.

## REMOVAL AND REPLACEMENT OF THE WATER PUMP ASSEMBLY

//////////////////// **WARNING** //////////////////////

**Disconnect electrical power supply to icemaker whenever adjustment procedures are performed.**

////////////////////////////////////

To remove the water pump assembly:

1. Remove screws and remove both front panels.
2. Remove plug from bottom of the sump and drain water from the sump into a bucket.
3. Unplug the wire harness from the water pump.
4. Remove two screws from the pump bracket to the icemaker base.
5. Remove three hose clamps by twisting and sliding the clamps at the clamp joints.
6. Pull the water pump and bracket forward to remove the bracket from the icemaker base.
7. Remove screw and remove the water pump ground wire from the icemaker base.
8. Separate the water pump from the tygon tubes.
9. Remove screws and separate the water pump from the bracket.

To replace the water pump assembly, reverse the removal procedures.

# BH750/1000 BIN

## BH750 MODULAR BIN

BH750 BIN

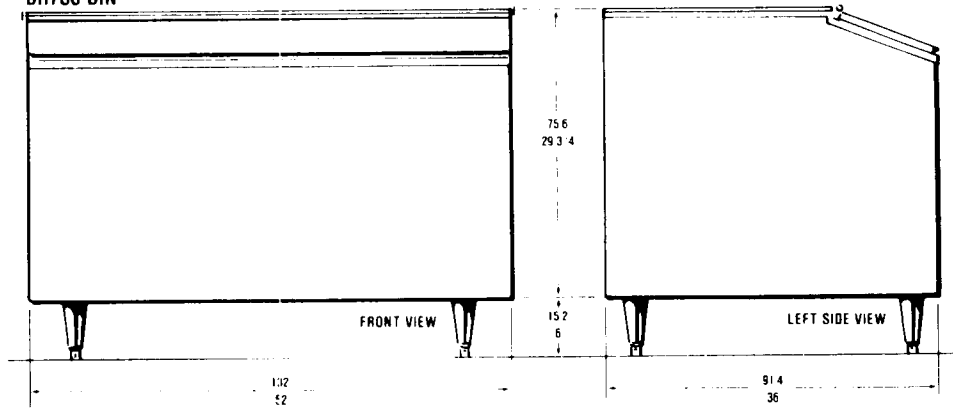

## BH1000 STORAGE BIN

