

CM450D

TABLE OF CONTENTS

GENERAL INFORMATION & INSTALLATION	
For the Installer	2
For the Electrician	6
For the Plumber	7
Final Checklist	8
OPERATION	
Start-Up	9
Operation	12
Operation - Electrical Sequence	14
MAINTENANCE & CLEANING INSTRUCTIONS	
Icemaker	17
Ice Storage Bin	17
Cleaning - Icemaker	17
COMPONENT DESCRIPTION	20
SERVICE DIAGNOSIS	24
ADJUSTMENT PROCEDURES	
Bin Thermostat Control	26
Water Regulator Assembly (Water-Cooled)	26
Cube Size Control	27
Timer & Switch Assembly	27
REMOVAL AND REPLACEMENT PROCEDURES	
Drier	28
Evaporator Plate Assembly	28
Compressor Assembly	29
Condenser (Air-Cooled)	30
Condenser (Water-Cooled)	30
Fan Motor (Air-Cooled)	30
Cube Size Control	31
Water Distributor Tubes and Manifold Tubes	31
Bin Thermostat Control	31
Inlet Water Solenoid Valve Assembly	31
Water Pump Assembly	32

LIST OF ILLUSTRATIONS

Specifications	3
Component Location	4
Stacking Instructions	5
Electrical Connections	6
Water & Drain Connections	7
Final Checklist	8
Timer Cam Positions	9
Ice Cube Size and Shape	10
Cube Size Adjustment	11
Freezing Cycle	12
Harvest Cycle	13
Maintenance & Cleaning	18
Component Description	19
Adjustment Procedures	26
Removal and Replacement	29
PARTS LIST AND WIRING DIAGRAMS	1
(Printed in Yellow)	
PARTS LIST:	
Component Location	3
Cabinet Assembly (Part I)	4
Cabinet Assembly (Part II)	5
Air-Cooled Refrigeration System	6
Water-Cooled Refrigeration System	7
Water System	8
Control Box	9
WIRING DIAGRAMS:	
CM450AE-32C (208-230/60/1) Air-Cooled	10
CM450WE-32C (208-230/60/1) Water-Cooled	11
CM450AE-32D (208-230/60/1) Air-Cooled	12
CM450WE-32D (208-230/60/1) Water-Cooled	13

**THIS PAGE
INTENTIONALLY
LEFT BLANK**

CM450D FOR THE INSTALLER

INTRODUCTION

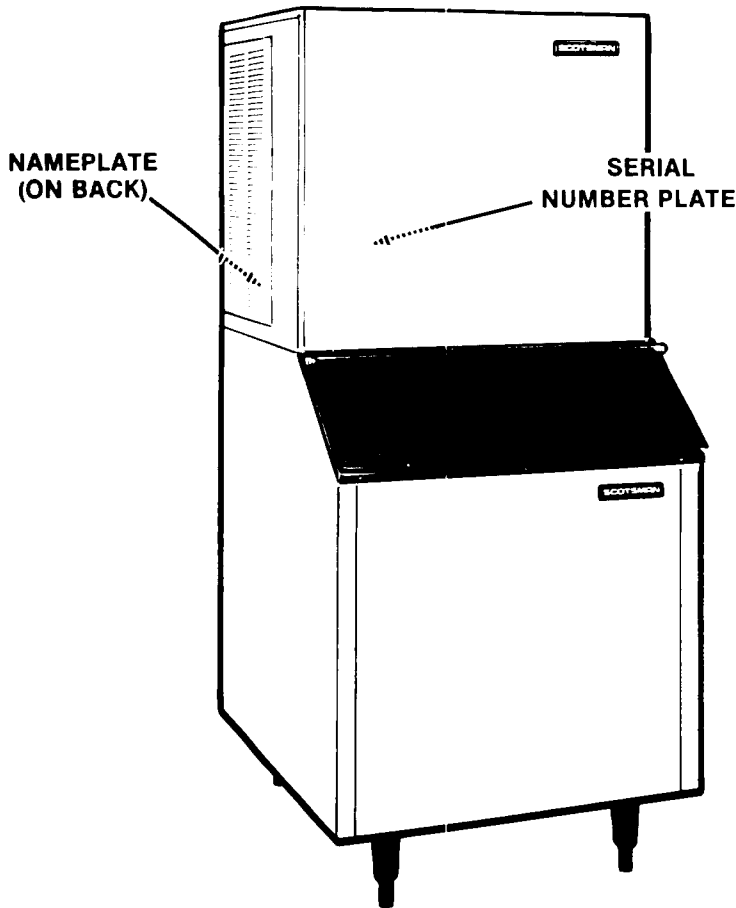

These instructions provide the specifications and the step-by-step procedures for the installation, start up and operation for the Scotsman Model CM450D Modular Cuber.

The Model CM450D Modular Cubers are quality designed, engineered and constructed, and are thoroughly tested icemaking systems, providing the utmost in flexibility to fit the needs of a particular user.



NAME PLATE

MODEL NUMBER				
SERIAL NUMBER				
A.C. SUPPLY VOLTAGE				
MINIMUM CIRCUIT AMPACITY				
MAXIMUM FUSE SIZE *				
HEATER WATTS				
REFRIGERANT	CHARGE	OZ		
MOTORS	VOLTS	R L A / F L A	W/H P	L R A
COMPRESSOR				
FAN				
DRIVE				
OTHER				
DESIGN PRESSURE		LOW		HIGH
* OR HACR TYPE CIRCUIT BREAKER				

SCOTSMAN

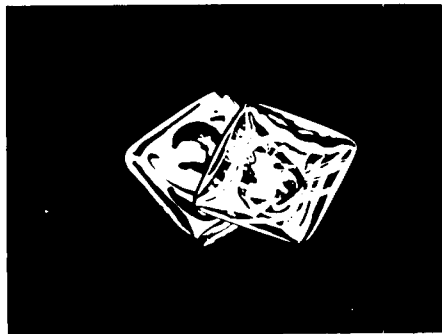

SCOTSMAN CONTOUR CUBE

SERIAL NUMBER PLATE

MODEL NUMBER		
SERIAL NUMBER		
VOLTS/HERTZ/PHASE		
MAXIMUM FUSE SIZE		
REFRIGERANT	CHARGE	OZ

This product qualifies for the following listings:



This icemaker has been engineered to our own rigid safety and performance standards. The National Sanitation Foundation (NSF) seal, signifies that it is listed with NSF and that it complies with the materials and construction standards of NSF. In addition, the Underwriters Laboratories, Inc., (UL) Listing Mark and the Canadian Standards Association (CSA) Monogram, both signify that its construction and design have been inspected and tested by them. NSF, UL and CSA inspectors also periodically examine production icemakers at the factory, to assure continued compliance.

To retain the safety and performance built into this icemaker, it is important that installation and maintenance be conducted in the manner outlined in this manual.

CM450D FOR THE INSTALLER

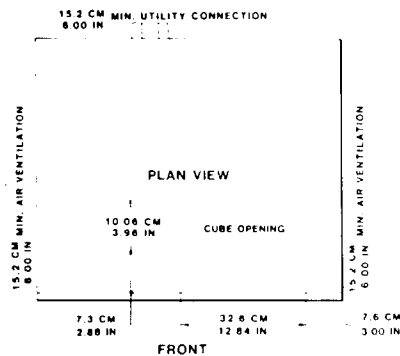

BH500 MODULAR STORAGE BIN OR HTB ICE STORAGE BIN

INSTALLATION NOTE: Allow 6" minimum space at sides and back for ventilation and utility connections.

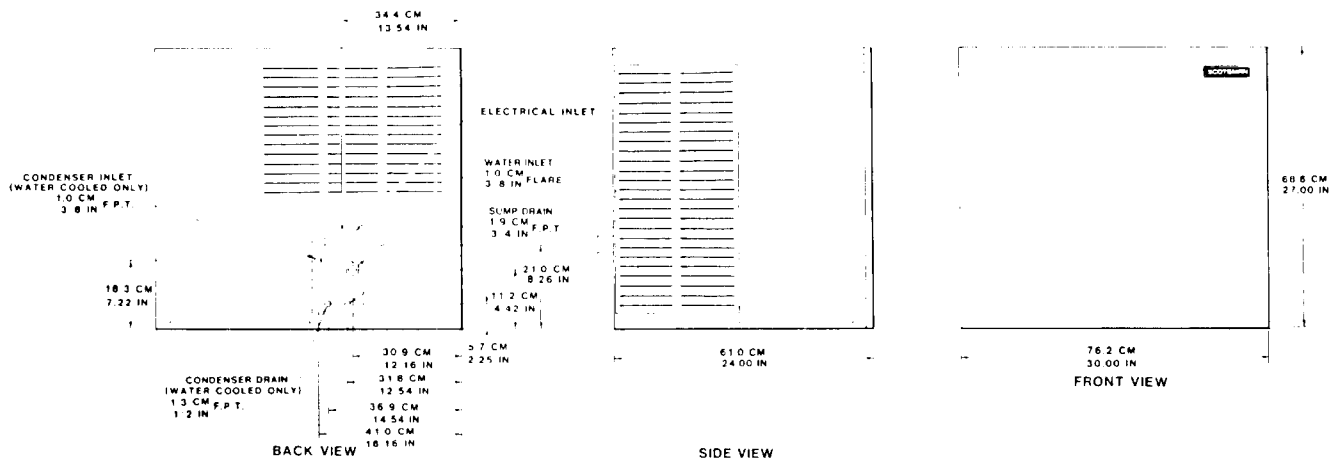

We reserve the right to make product improvements at any time. Specifications and design are subject to change without notice.

SPECIFICATIONS

Model Number	(Height - w/o Legs) Dimensions H" x W" x D"	Cube Size	Cond. Unit	Finis ^{**}	Basic Electrical	Comp. H.P.	No. of Wires	Min. Circuit Ampacity †	* Max. Fuse Size	Shlp. Wt. lbs./kg.
CM450AE-32D	27 x 30 x 24	Contour	Air	ES	208-230/60/1	1.0	2	18.0	20	175/79

Ice production capacity at 90°A/70°W
Air-cooled: 300 lbs.

** (ES) Sandalwood, Leathergrain embossed steel with high gloss baked enamel finish.
Use this value to determine minimum wire size as per National Electric Code Standards.

★ Or HACR type circuit breakers.

IMPORTANT OPERATING REQUIREMENTS

	MINIMUM	MAXIMUM
Air Temperatures	50°F (10.0°C)	100°F (38°C)
Water Temperatures	40°F (4.4°C)	100°F (38°C)
Water Pressures	20 lbs. gauge	120 lbs. gauge
Electrical Voltage Variations		
Voltage rating specified		
on nameplate	-5%	+10%

Extended periods of operation exceeding these limitations constitutes misuse under the terms of Scotsman Manufacturer's Limited Warranty, resulting in a loss of warranty coverage.

NOTE: CM450's were manufactured in "A", "C" and "D" series. As of 1986, CM450AE-1C vs. CM450AE-1D. This manual is primarily for the "D" series, but applies as well to the prior models.

STORAGE BIN

The CM450D stacks onto Scotsman Bin Model's BH500, HTB500 or HTB350.

Refrigerant R502
Charge per nameplate rating.

STANDARD LEGS: Furnished with storage bin. Four metal legs screw into mounting plates on cabinet base. Provide 6" minimum height including adjustable leveling foot. Black enamel finish.

OPTIONAL LEG KIT, KLP2S: Nickel plated, brushed metal finish with stainless steel foot. Recommended for stainless steel cabinets.

SPKCMD-1: Optional stainless steel panel kit for CM450D model.

CM450D FOR THE INSTALLER

AIR-COOLED ASSEMBLY

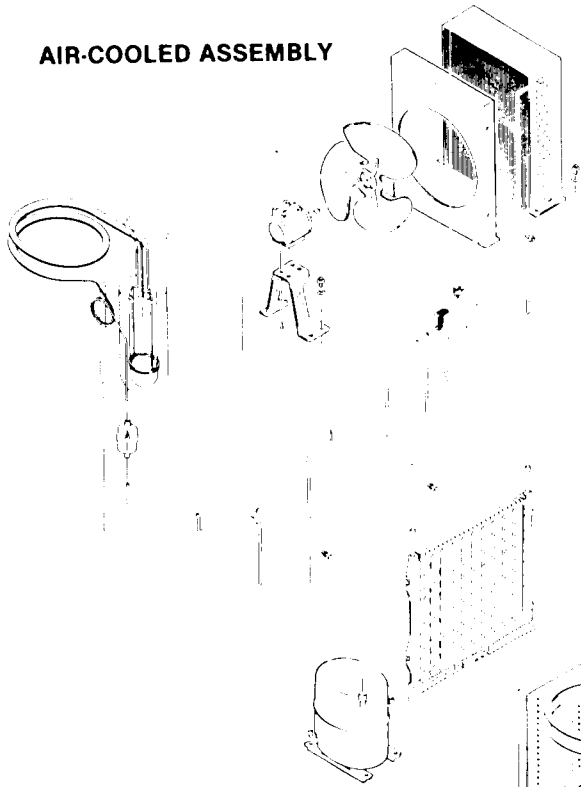

WATER SYSTEM

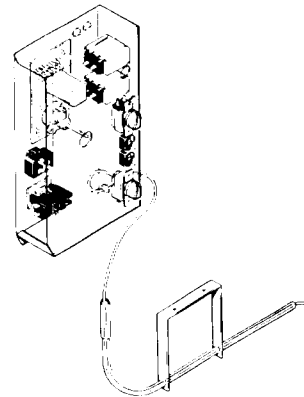
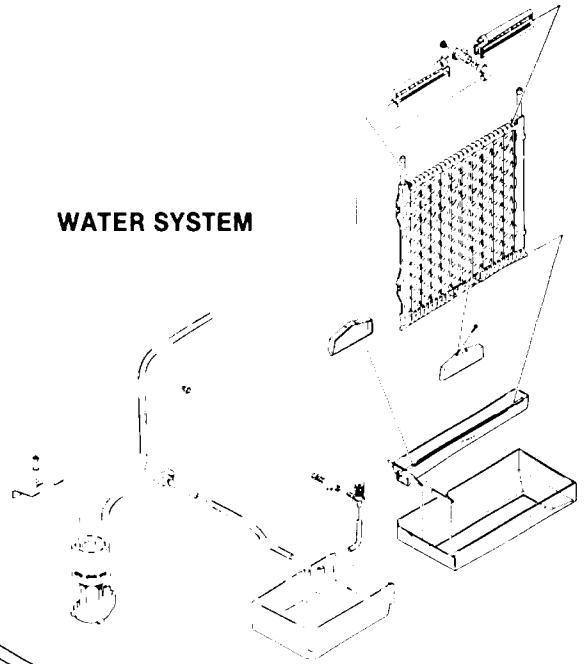

BIN THERMOSTAT BRACKET

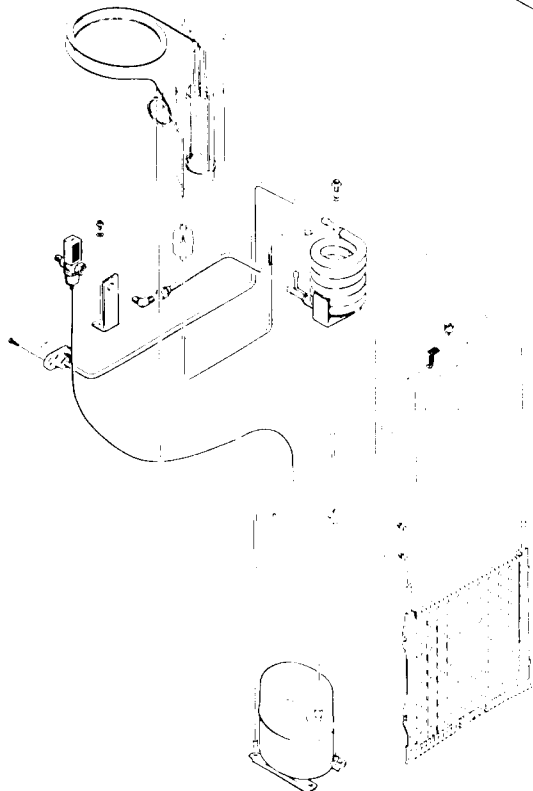

WATER-COOLED ASSEMBLY

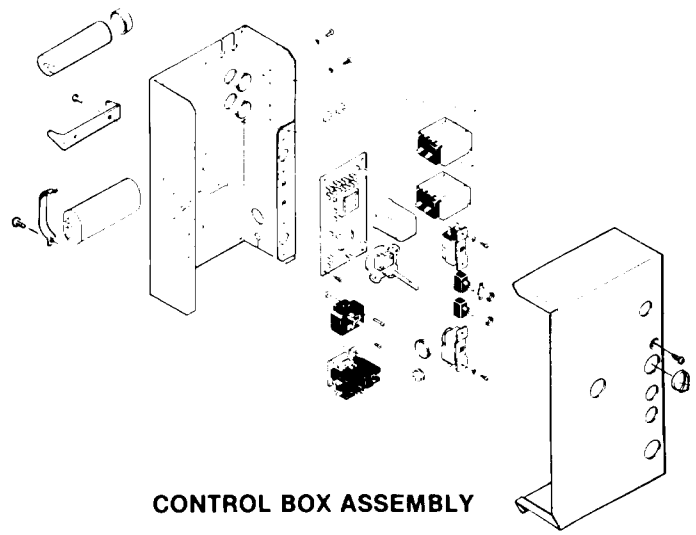

CONTROL BOX ASSEMBLY

CM450D FOR THE INSTALLER

LOCATION & LEVELING

1. Arrange for proper electric, water and drain. See instructions for the plumber and for the electrician.
2. After mounting the legs, position the ice storage bin in the selected location which should have a minimum room temperature of 50-degrees F. and maximum room temperature of 100-degrees F. Level the bin, adjusting the leg levelers in both the front to rear and side to side directions. Select a well-ventilated location for the air-cooled condenser.
3. Inspect the bin top mounting gasket which should be flat, with no wrinkles, to provide a good water seal when the Cuber is installed on top of the bin. Remove baffle from bin to gain access.
4. Install the modular cuber on top of the bin using care to be sure a good seal is made between the two cabinets. Align the holes in the bottom rear of the cabinet to mate with the two mounting straps on the top rear of the bin.
5. Use bolts and straps found in hardware package to secure the ice machine. When alignment and leveling are completed, tighten the bolts to secure the mounting straps.

3. Carefully uncoil the capillary tube to the icemaker and route the capillary tube through the routing hole provided in the sump and through the full length of the bin thermostat bracket.

NOTE: When stacking, route the bin thermostat control from the upper ice machine through the routing hole provided in the sump of the lower icemaker and through the bin thermostat control bracket.

NOTE: Extend bin thermostat capillary tube through entire length of the tubular section of the bin thermostat bracket. When properly installed, the tip of the capillary tube should be flush with the tip of the bin thermostat bracket.

STACKING INSTRUCTIONS

NOTE: Only stack "D" models onto "D" models.

DO NOT stack "D" models onto "C" or "A" models.

When stacking two units, remove the top panel from the lower icemaker. (The top removed from the lower icemaker will no longer have any function.)

Carefully lift the uncrated top unit onto the bottom one and align the two cabinets. Use of a mechanical lift is recommended for this step.

At the back of the two icemakers, bolt the upper icemaker cabinet to the lower icemaker cabinet using the mounting straps and bolts from the hardware package.

BIN THERMOSTAT INSTALLATION

1. Remove cap from bin thermostat bracket. Insert bin thermostat bracket up through routing hole in sump.
2. Attach the bin thermostat bracket to the bottom of the cuber base using the thumb screws and threaded holes provided.

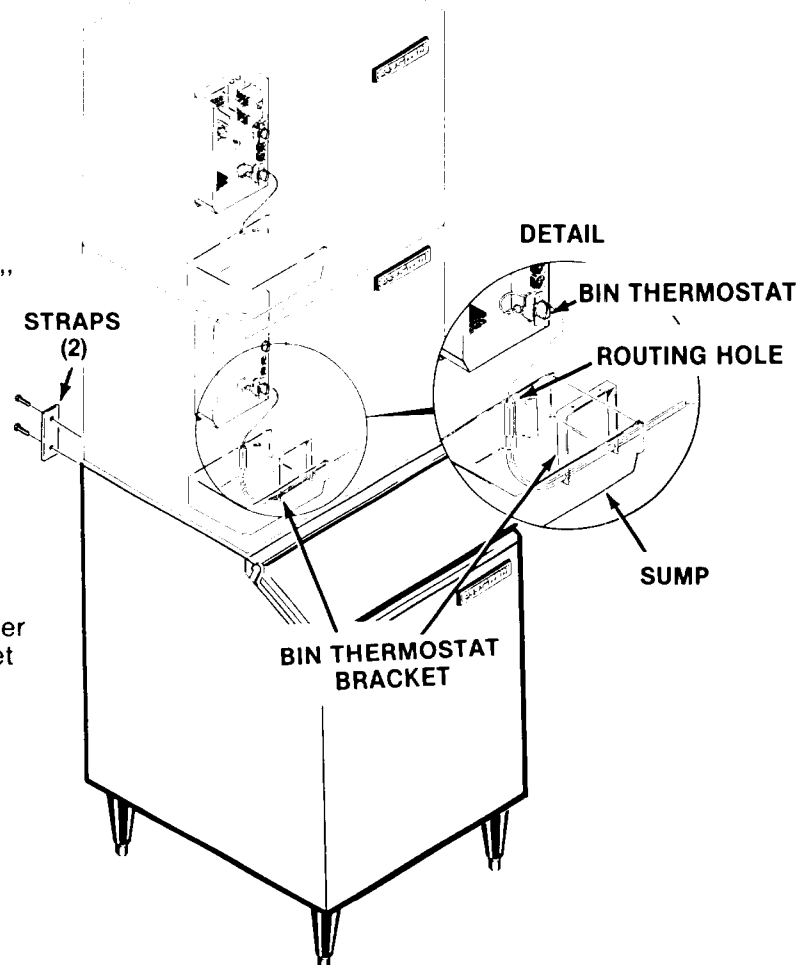

CM450D FOR THE ELECTRICIAN

CONFORM TO ALL APPLICABLE CODES

ELECTRICAL CONNECTIONS

SEE NAMEPLATE for current requirements to determine wire size to be used for electrical hookup. The cuber requires a solid chassis-to-chassis earth ground wire. See Wiring Diagram.

Be certain the cuber is connected to its own electrical circuit and individually fused. Voltage variation should not exceed ten percent of the nameplate rating, even under starting conditions. Low voltages can cause erratic operation and may be responsible for serious damage to the icemaker.

Electrical connections are made at the rear of the icemaker, inside the junction box.

All external wiring should conform to the national, state and local electrical code requirements. Usually an electrical permit and services of a licensed electrician will be required.

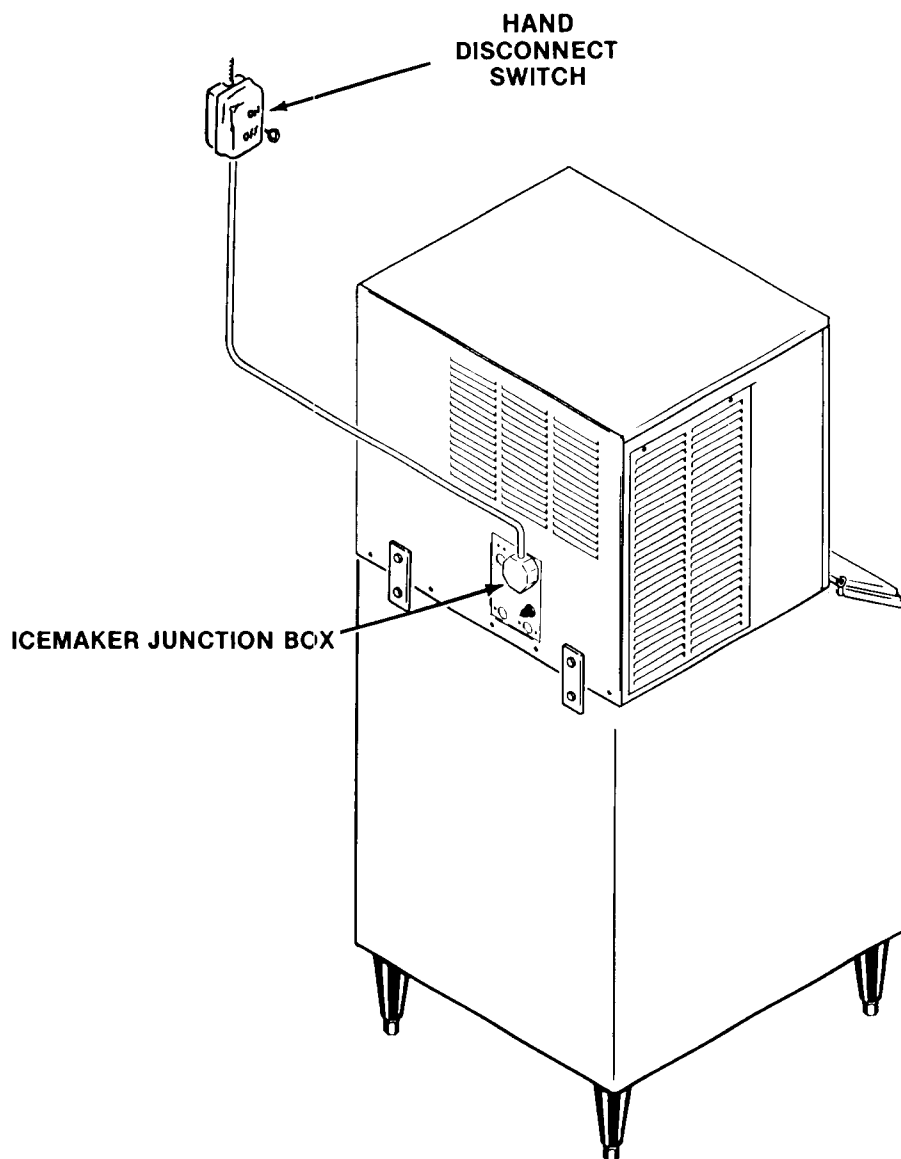

CM450D FOR THE PLUMBER

CONFORM TO ALL APPLICABLE CODES

WATER SUPPLY AND DRAIN CONNECTIONS

The recommended water supply line is a 3/8-inch O.D. copper tubing with a minimum operating pressure of 20 PSIG and a maximum of 120 PSIG. Connect to cold water supply line with standard plumbing fittings, with shutoff valve installed in an accessible place between the water supply and the cuber. In some cases a plumber will be required.

DRAIN CONNECTIONS: All drains are gravity type and must have a minimum of 1/4-inch fall per foot on horizontal runs. The drains to be installed to conform with the local plumbing code. Install a vertical open vent on drain line high point to ensure good draining. The ideal drain receptacle is a trapped and vented floor drain.

Recommended bin drain is 5/8-inch O.D. copper tubing and should be vented and run separately. Insulation for high humidity areas is recommended.

The ice machine sump drain is 3/4" FPT. There must be a vent at this connection for proper sump drainage.

WATER-COOLED MODELS: On water-cooled models, a separate cold water supply inlet is required, to be connected to a second 3/8-inch female pipe thread (FPT) fitting at the rear of the cabinet. Additional drain lines are required to drain the water-cooled condenser, and they must not interconnect to any other of the units drains.

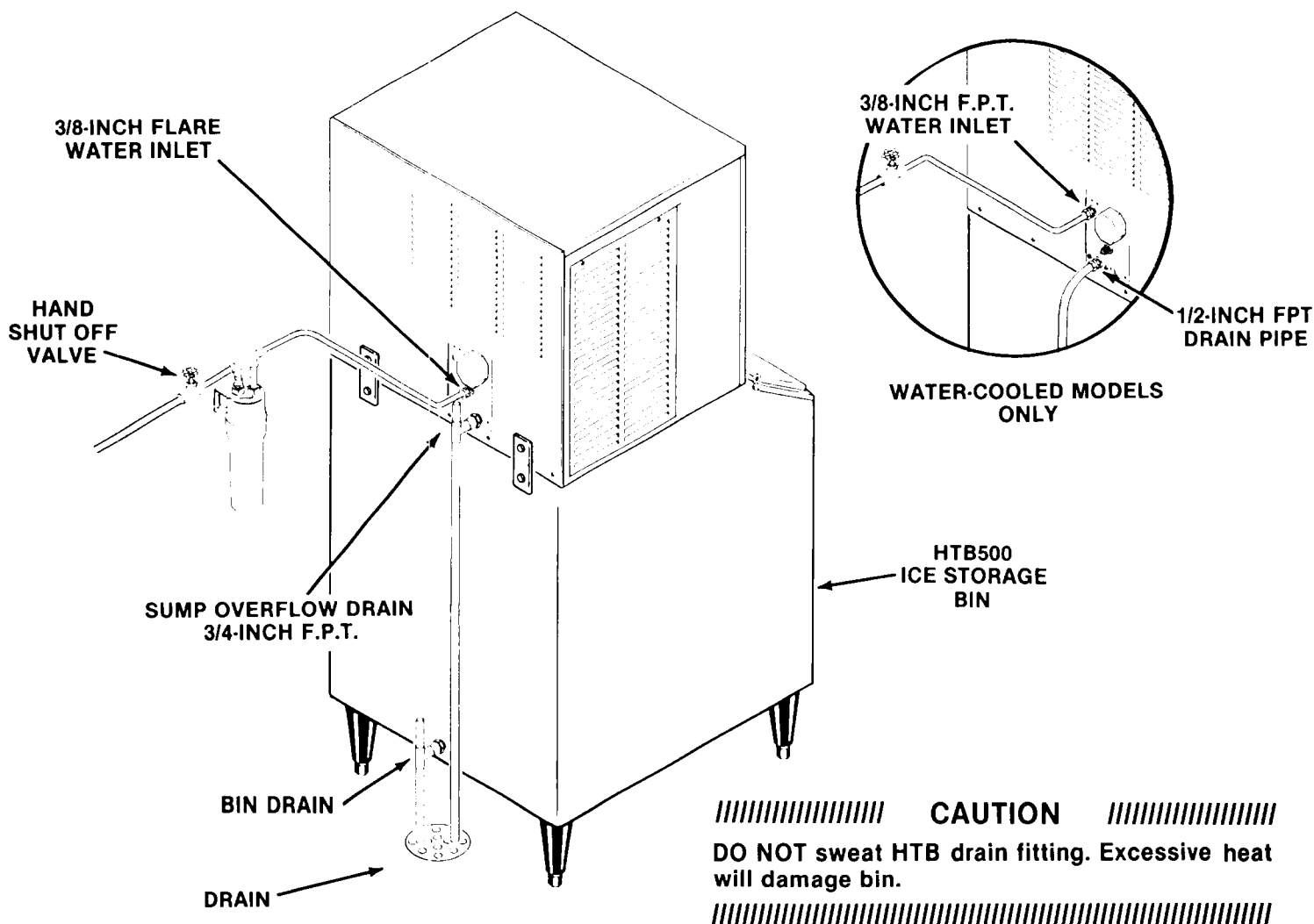

Water Supply and Drain Connection

CM450D FOR THE INSTALLER

FINAL CHECK LIST

1. Is the cabinet in a room where ambient temperatures are within the minimum and maximum temperatures specified?
2. Is there at least six inches clearance at both sides of the cabinet for proper air circulation? (Air-Cooled models)
3. Has water supply pressure been checked to insure a minimum of 20 PSIG and a maximum of 120 PSIG operating pressure?
4. Is the cabinet level?
5. Check that any shipping material has been removed from inside the cabinet.
6. Has the bin thermostat and bracket been properly installed?
7. Check that the drain troughs are properly secured to the bottom of the evaporator plates.
8. Have all electrical and piping connections been made?
9. Is the water supply line shut-off valve installed and electrical wiring properly connected?
10. Check all refrigerant lines and conduit lines, to guard against vibration or rubbing and possible failure.
11. Have the bin and cabinet been wiped clean?
12. Has the Manufacturer's Registration Card been properly filled out? Check for correct model and serial numbers from Serial nameplate, then mail the completed card to the SCOTSMAN factory.
13. Has the owner/user been given the Service Manual and instructed how to operate and maintain the icemaker?
14. Has the owner been given the name and telephone number of the authorized SCOTSMAN Service Agency serving him?

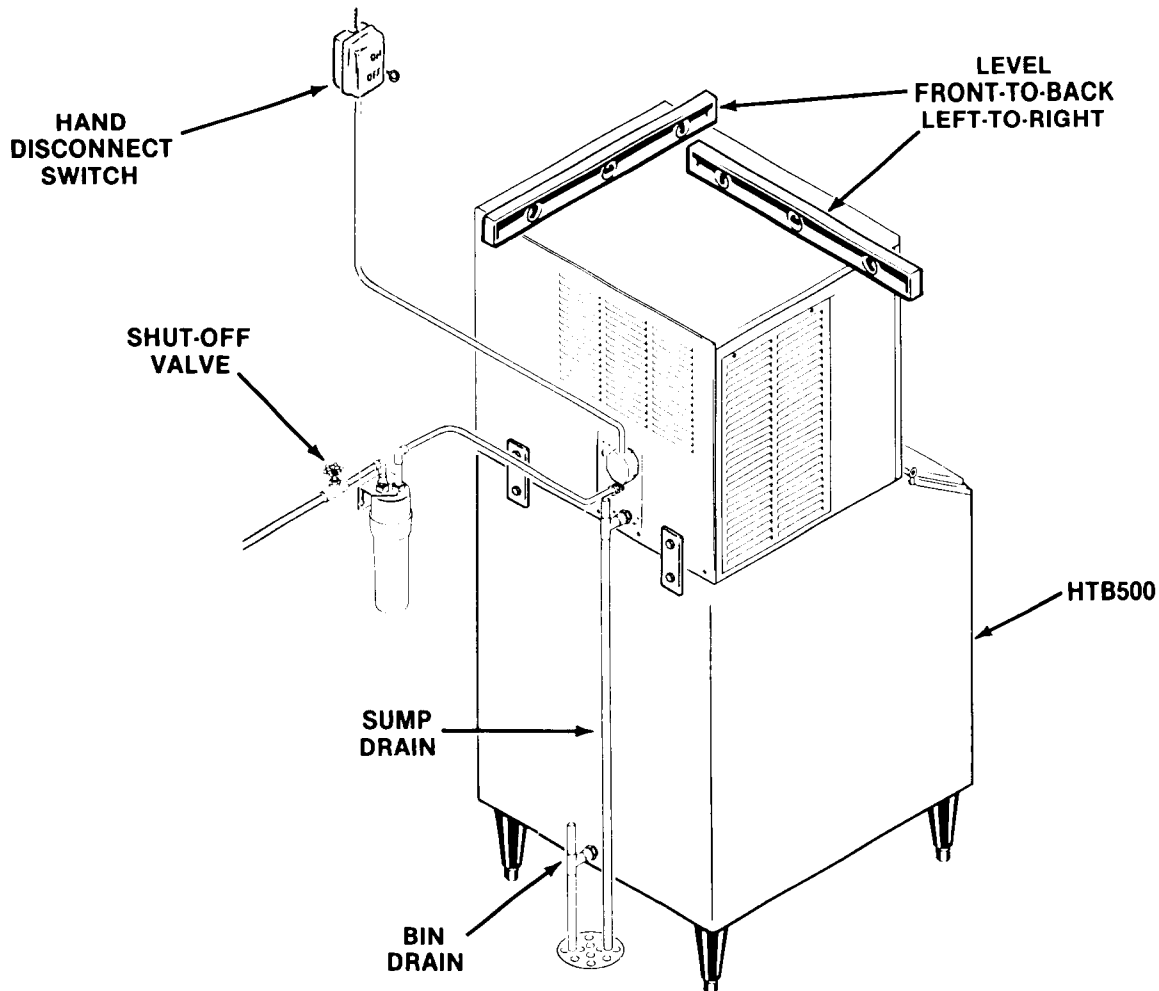

CM450D START-UP

START-UP

1. Remove front panel by pulling out to unsnap.
2. Remove two screws and the control box cover.
3. Remove four thumb screws and the evaporator cover.
4. Check that the two toggle switches, the MASTER ON-OFF toggle switch and the COMPRESSOR ON-OFF toggle switch are in the OFF position, on the control box.
5. OPEN the water supply line shutoff valve.
6. Inside the control box is the shaft of the timer and the switch assembly. Rotate the shaft of the timer and switch assembly clockwise to start the timer. The timer starts when the actuator arm on the microswitch drops off outer cam into cam slot. See Timer Cam Positions. An audible click can be heard, but in a noisy area, look at the cam and switch to observe the event.

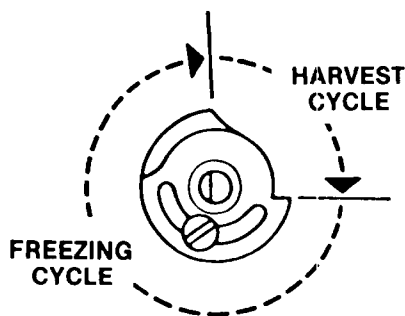
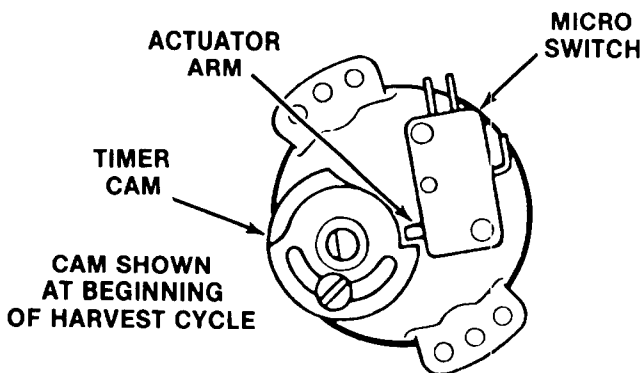

CAM SHOWN DIVIDED INTO TYPICAL FREEZING & HARVEST CYCLES

Timer Cam Positions

7. Move the master ON-OFF toggle switch, the top toggle switch, to the ON position.
8. Observe water fill cycle:

Water pump operates and water inlet solenoid valve OPENS, incoming water flows from the valve through the tubing, the reservoir fills and excess water is overflowed through the stand pipe. This cycle will take about three minutes. Timer will close the water inlet solenoid valve and the water fill cycle is complete.

Advancing the shaft of the timer and switch assembly into a new harvest cycle, restarts the timer and allows a check that: Water inlet solenoid valve OPENS and the reservoir overflows through the stand pipe. Water inlet valve CLOSSES, stopping water overflow.

The water pump is operating, as seen by water moving through the tygon tube, up to the water distributor at the top of each evaporator plate, where water is uniformly dispensed and cascades down both sides of the evaporator plate and drains back into the sump assembly for recirculation.

9. Check that the water cascades down over each cube mold and into the sump.
10. When the second cycle is completed, move the compressor ON-OFF toggle switch, to the ON position.
11. Check operation of the freezing cycle:

The compressor is operating.

The icemaking process begins; feeling the metal parts of the evaporator plate reveals cold temperature, very shortly ice begins to form. Tubing will become frosted at the top of the evaporator plate.

Freezing time will range between 10 and 15 minutes. Longer time for temperatures above 70-degrees F. and shorter time required when temperatures are below 70-degrees F. Average complete cycle time is about 13 minutes.

CM450D START-UP

12. Observe second and third cube harvest.
Check size of SCOTSMAN CONTOUR CUBE
Unlike other SCOTSMAN cubes which are made in a definite molded shape, contour cubes are produced in indentations and many shapes and sizes of contour cubes may be produced — only ONE size and shape combination is correct.

An under-charged refrigeration system produces smaller cubes at the top of the evaporator plate and large cubes at the bottom. Charge system per NAMEPLATE specifications.

Charge Refrigeration System with **REFRIGERANT 502 ONLY.**

In areas where extreme problem water condition exists, filtering or purifying equipment is recommended. Contact SCOTSMAN ICE SYSTEMS, Service Department, Albert Lea, Minnesota 56007 for further details.

TOO LARGE

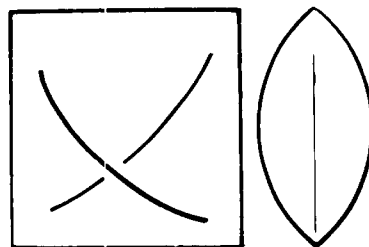

Too LARGE — may cause evaporator freeze ups. Adjust cube size control counter-clockwise to obtain smaller cubes

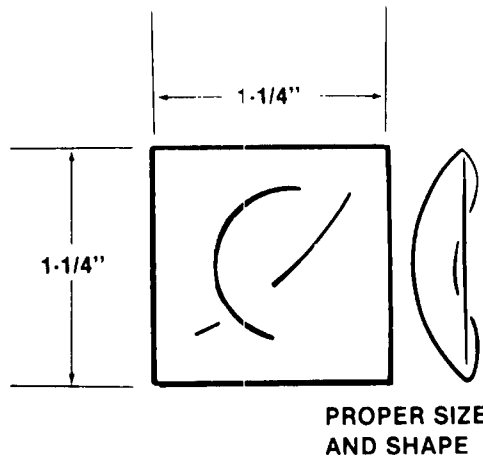
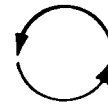

PROPER SIZE AND SHAPE of the contour cube. Icemaker operates at peak efficiency when a cube this size and shape is produced. A finely tuned system produces vertical strips of ice which easily break when they fall.

TOO SMALL

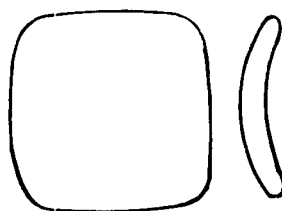

TOO SMALL. To obtain proper size cubes, adjust cube size control clockwise. May cause freeze up problems due to poor harvest.



Ice Cube Size & Shape

CM450D START-UP

ADJUSTMENT OF CUBE SIZE

To produce **SMALLER** sized ice cubes:

Locate cube size control knob, in the front of the control box.

Rotate the adjusting screw one-eighth of a turn **COUNTERCLOCKWISE** to **WARMER**.

Observe size of the ice cubes in the next two ice cube harvests and adjust in one-eighth turn or less increments, until correct ice cube is achieved.

To produce **LARGER** ice cubes:

Locate cube size control on the front of the control box

Rotate the adjusting screw one-eighth of a turn **CLOCKWISE** to **COLDER**.

Observe size of ice cubes in the next two cube harvests and adjust in one-eighth turn or less increments, until correct ice cube size is achieved.

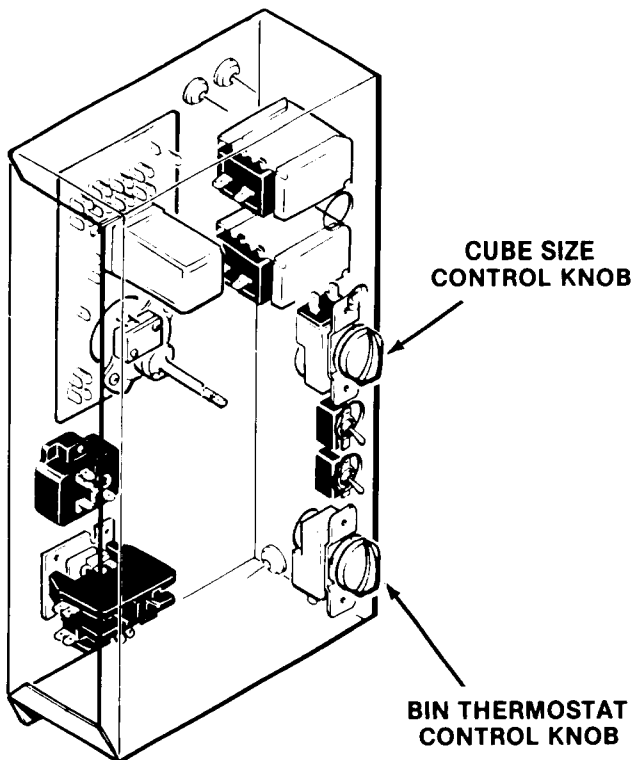

ROTATE ADJUSTMENT KNOB COUNTER-CLOCKWISE TO PRODUCE SMALLER CUBES.

ROTATE ADJUSTMENT KNOB CLOCKWISE TO PRODUCE LARGER CUBES.

BIN THERMOSTAT OPERATION

Check texture of ice cubes; when partially cloudy throughout, suggests icemaker is operating short of water; or, possibly an extreme problem water condition exists, where filtering or purifying equipment is recommended. Contact **SCOTSMAN ICE SYSTEMS**, Service Department, Albert Lea, Minnesota 56007 for further details. See **SERVICE DIGNOSIS** chart, for shortage of water symptoms and corrections.

13. With the icemaker in the harvest cycle, hold ice against the bin thermostat control bulb to test shutoff, which should cause the icemaker to shut OFF at the **END OF THE HARVEST CYCLE**.

Within minutes after the ice is removed from the sensing bulb, the bulb will warm up and cause the icemaker to restart. This control is factory set and should not be reset until testing is performed.

14. Replace control box cover and all cabinet panels and screws.
15. Thoroughly explain to the owner/user the significant specifications of the icemaker, the start up and operation, going through the procedures in the operating instructions. Answer all questions about the icemaker by the owner; and inform the owner of the name and telephone number of the authorized **SCOTSMAN** Distributor, or service agency serving him.

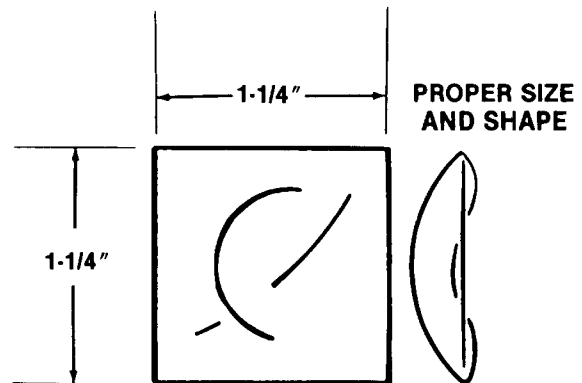

CM450D OPERATION

OPERATION

FREEZING CYCLE

Water from the sump assembly is pumped to the water distributor system, at the top of each evaporator plate. From the water distributor the water cascades by gravity over all cells of the plate and to the sump assembly below, for recirculation. At the beginning of the freezing cycle, the electrical circuit is completed to the compressor and the water pump. The water pump operates continuously, through both the freezing cycle and the harvest cycle.

In water-cooled models, water also flows through the condenser and out the drain. While in the condenser, water removes heat from the refrigerant and allows the refrigerant to condense from a gas to a liquid.

In the compressor, gaseous refrigerant is compressed and discharged into the condenser, as a high pressure, high temperature gas. The refrigerant is cooled by either air or water, and condenses into a high pressure, medium temperature liquid. This liquid refrigerant then passes through a small capillary tube, where the temperature and pressure of the liquid refrigerant are lowered and it next enters the evaporator plates. The refrigerant is warmed by

the water cascading over the Evaporator plate and begins to boil off and become a gas. The refrigerant next travels through the accumulator and the heat exchange area of the suction line where any remaining liquid refrigerant boils off and returns to the compressor as a low pressure, low temperature gas, and the cycle starts again.

During the freezing cycle, the hot gas solenoid valve is CLOSED and the water inlet solenoid valve is CLOSED.

When the ice cubes are partially formed, the cube size control will sense the temperature at which it is preset to CLOSE. This will complete the electrical circuit to the timer. The timer then controls the remainder of the freezing cycle.

The timer will keep the icemaker operating in the freezing cycle for a selected length of time. This will give the ice cubes time to fully form. After that selected length of time, the timer will switch the icemaker into the harvest cycle, through the contacts of the timer assembly microswitch.

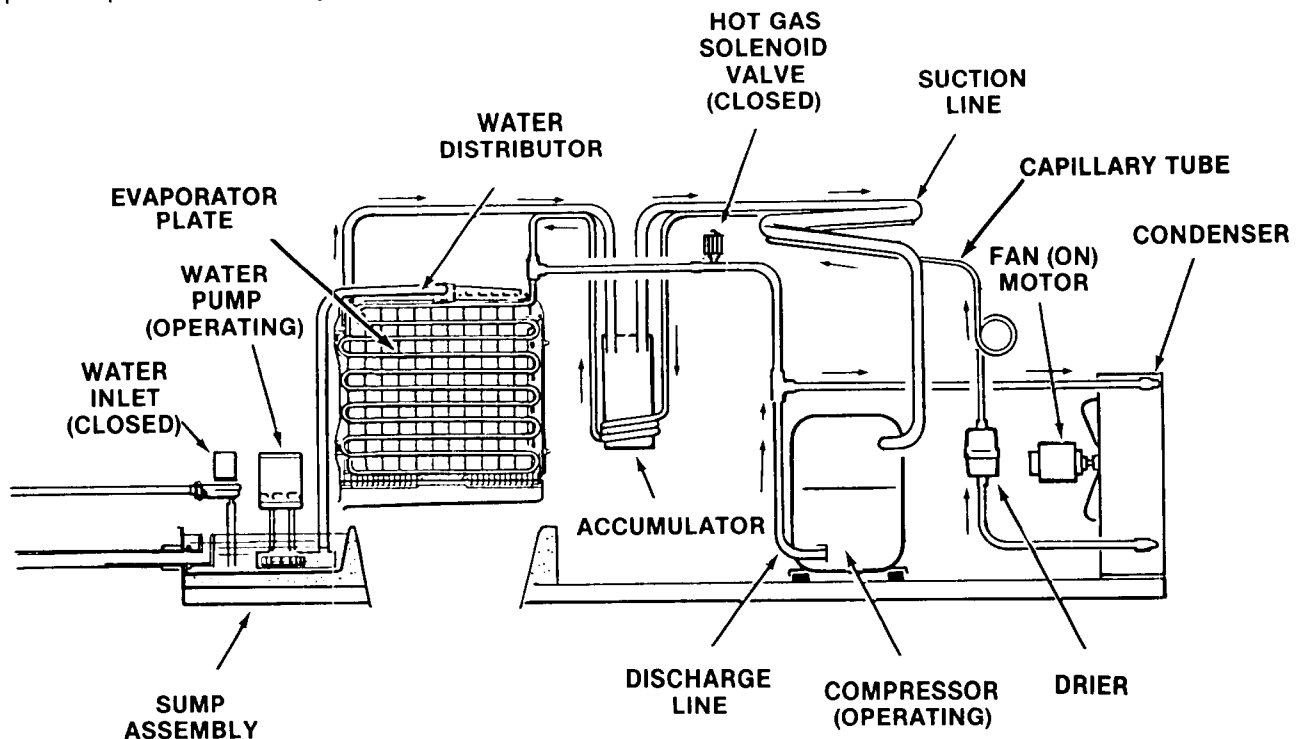

Freezing Cycle

CM450D OPERATION

HARVEST CYCLE - HOT GAS BYPASS

When the timer switches the icemaker into the harvest cycle, high pressure, high temperature gas refrigerant being discharged from the compressor is diverted from the condenser through the hot gas solenoid valve into each evaporator plate. During this cycle, the gaseous refrigerant bypasses the condenser and the capillary tube.

In the electrical circuit, both the compressor and the water pump are operating and the hot gas solenoid valve is energized and OPEN and the water inlet solenoid valve is OPEN.

The finished ice cubes are released from the sides of each evaporator plate, by the warming effect of the hot gas condensing in each evaporator plate and the water cascading over the ice cubes. The released ice cubes drop into the ice storage bin below.

At the end of the harvest cycle, the timer cam will push the actuator arm to the microswitch IN. If the bin thermostat is still CLOSED, a whole new cycle will begin. If the bin thermostat is OPEN, the icemaker will shut OFF, at this time.

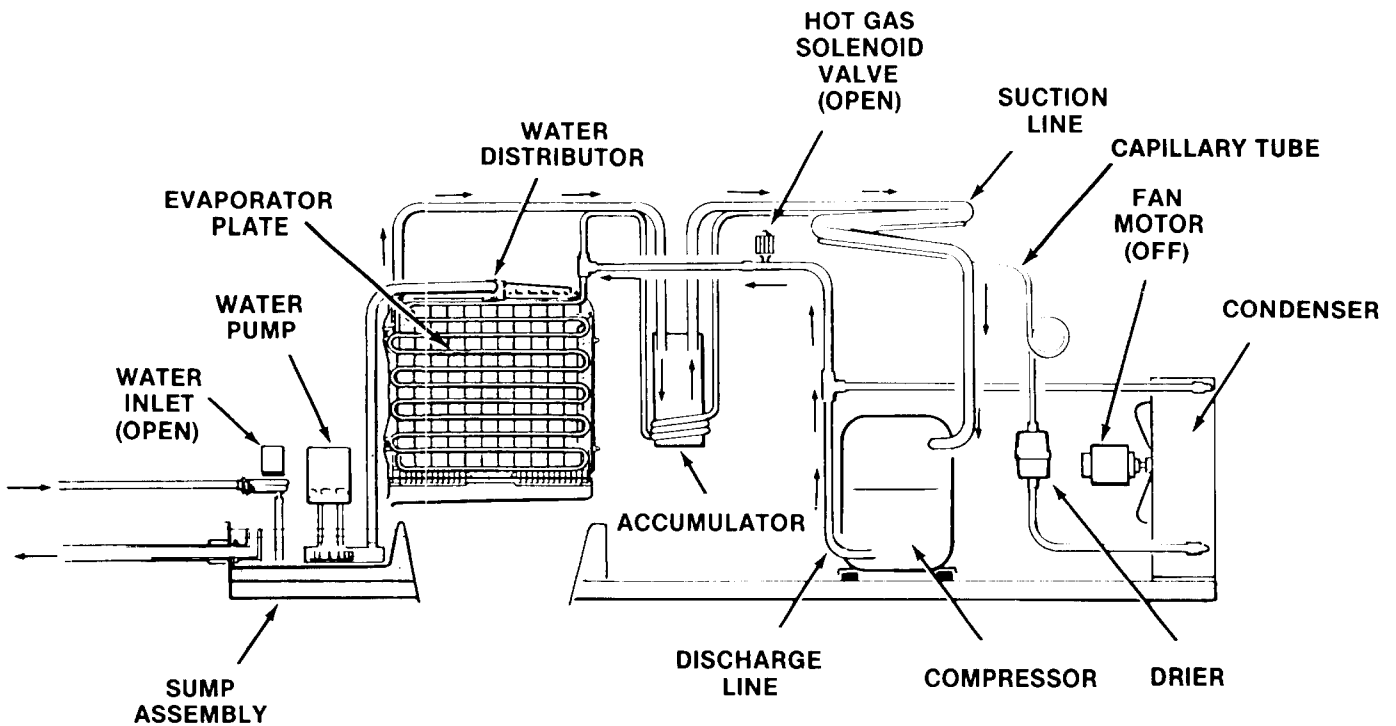

Harvest Cycle

CM450D OPERATION - ELECTRICAL SEQUENCE

The following charts illustrate which switches and which components are ON or OFF during a particular phase of the icemaking cycle.

Refer to the wiring diagram for a reference. Remember, the wiring diagram shows the unit as it is in the Timed Freeze Cycle.

BEGINNING FREEZE

ELECTRICAL COMPONENTS (LOADS)	ON	OFF
Compressor	X	
*Fan Motor (Air-cooled only)	X	
Hot Gas Valve		X
Inlet Water Valve		X
P.C. Board Relay Coil	X	
Timer		X
Water Pump	X	

SWITCHES	ON	OFF
Bin Thermostat	X	
Cube Size Thermostat		X
H.P. Fan Control	X	
Toggle - Master	X	
Toggle - Compressor	X	
H.P. Control	X	
Timer Micro Switch N.C.	X	
Timer Micro Switch N.O.	X	
Hi Temp Switch	X	

*The fan control will open and close with changes in discharge pressure, but will usually be closed during early freeze so the fan will usually be ON.

At the beginning of the freeze cycle the timer is not turning, but the icemaker is refrigerating the water starting to turn the water into ice.

CM450D OPERATION - ELECTRICAL SEQUENCE

TIMED FREEZE

ELECTRICAL COMPONENTS (LOADS)	ON	OFF
Compressor	X	
*Fan Motor (Air-cooled only)	X	X
Hot Gas Valve		X
Inlet Water Valve		X
P.C. Board Relay Coil	X	
Timer	X	
Water Pump	X	

SWITCHES	ON	OFF
Bin Thermostat	X	
Cube Size Thermostat	X	
H.P. Fan Control	X	X
Toggle Switch - Master	X	
Toggle Switch - Compressor	X	
H.P. Control	X	
Timer Micro Switch N.C.	X	
Timer Micro Switch N.O.	X	
Hi Temp Switch	X	

After the icemaker has cooled the water and formed some ice on the evaporator, the evaporator will have gotten cold enough to have the cube size control close. All this does is start and run the timer.

*The fan control will be opening and closing with the changes in discharge pressure, so the fan will be turning ON and OFF.

HARVEST

ELECTRICAL COMPONENTS (LOADS)	ON	OFF
Compressor	X	
*Fan Motor (Air-cooled only)		X
Hot Gas Valve	X	
Inlet Water Valve	X	
P.C. Board Relay Coil		X
Timer	X	
Water Pump	X	

SWITCHES	ON	OFF
Bin Thermostat	X	
Cube Size Thermostat		X
H.P. Fan Control		X
Toggle Switch - Master	X	
Toggle Switch - Compressor	X	
H.P. Control	X	
Timer Micro Switch N.C.	X	
Timer Micro Switch N.O.	X	
Hi Temp Switch	X	

The timer has now turned far enough so that the micro-switch plunger has dropped into the gap in the cam, this breaks the circuit to the relay in the P.C. Board - and that puts the machine into the Harvest cycle, where the hot gas valve and inlet water valve have opened to harvest the ice. When ice is on the bin control, it will open and at the end of the harvest cycle shut off the machine.

*The fan control will keep the fan OFF during the harvest cycle until the discharge pressure builds up to 190 PSIG, probably near the very end of the harvest cycle, then the fan will come ON.

CM450D SERVICE SPECIFICATIONS

In servicing a machine, it is often useful to compare that individual units operating characteristics to those of a normally operating machine. The data that follows gives those characteristics; however, be aware that these values are for NEW, CLEAN machines. USE THESE NUMBERS AS A GUIDELINE ONLY.

COMPONENT

Timer - 1 revolution of the cam, in minutes	8
Harvest Time, preset, in minutes	2-1/4
Inlet Water Valve, water flow in g.p.m.	1/3

	CI	CO
Cube Size Control, Reverse Acting, Temperature range (+ 12°F. to - 6°F.)	—	—
Bin Thermostat, Temperature Range	38.5°-43.5°	33.5°-38.5°
High Pressure Safety Switch, psig Air-cooled	Manual	450
High Pressure Safety Switch, psig Water-cooled	Manual	350
Fan Pressure Control, in psig	210	193

OPERATING CHARACTERISTICS

On air-cooled models during the freezing cycle, the discharge pressure will slowly decline as the unit freezes ice; and at the same time, the suction pressure will also decline, reaching it's lowest point just before freeze. Compressor amps experience a similar drop.

On water-cooled, the discharge pressure is constant, maintained during the freeze cycle by the water regulating valve at 220 PSIG. However, suction pressure and compressor amps will still decline as the machine freezes ice.

FREEZE CYCLE

Average Discharge Pressure A/C	350-200 PSIG
Average Discharge Pressure W/C	220 PSIG
Suction Pressure at the end of the Freeze Cycle	20-25 PSIG
Freeze Time	10-16 Minutes
Ice Weight per cycle	2.5-3 lbs.
Compressor Amps, 5 minutes into Freeze Cycle	7.0-8.0

HARVEST CYCLE

Average Discharge Pressure	250-100 PSIG
Average Suction Pressure	150-110 PSIG
Harvest Time, assumed to be 2-1/4 minutes.	
This can be adjusted to suit local conditions.	

The values listed are representative of values seen at a wide range of air and water temperatures and are for a normal cube size.

When comparing these figures to field data, allow a variation from each end of the range given.

TO SERVICE REFRIGERATION SYSTEM:

TORQUE REFRIGERATION ACCESS VALVE CAPS TO 60-75 INCH POUNDS.

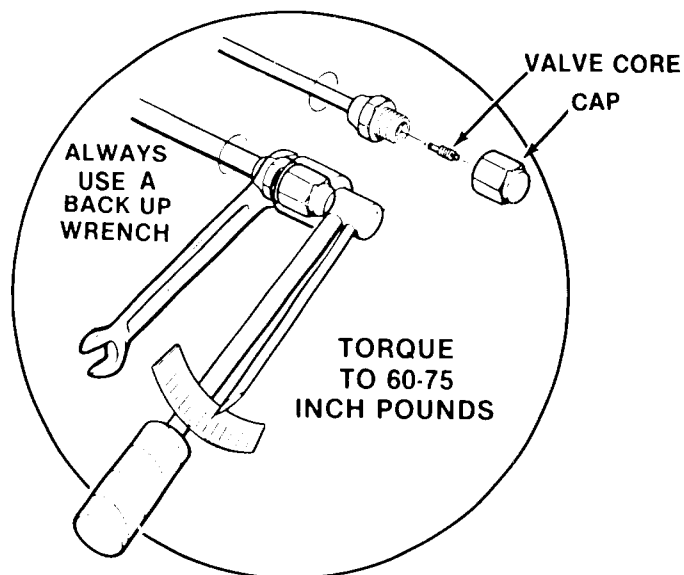

ALWAYS USE A BACK-UP WRENCH TO AVOID DAMAGE TO THE REFRIGERANT TUBING.

CM450D MAINTENANCE & CLEANING INSTRUCTIONS

////////////////////////////////////
A Scotsman Ice System represents a sizable investment of time and money in any company's business. In order to receive the best return for that investment, it MUST receive periodic maintenance.

It is the USER'S RESPONSIBILITY to see that the unit is properly maintained. It is always preferable; and less costly in the long run, to avoid possible down time by keeping it clean, adjusting it as needed and by replacing worn parts before they can cause failure. The following is a list of recommended maintenance that will help keep your machine running with a minimum of problems.

Maintenance and Cleaning should be scheduled at a MINIMUM of twice per year.

////////////////////////////////////

ICEMAKER

THE FOLLOWING MAINTENANCE SHOULD BE SCHEDULED AT LEAST TWO TIMES PER YEAR ON THIS ICEMAKER. CALL YOUR AUTHORIZED SCOTSMAN SERVICE AGENCY.

1. Check and clean or service any optional water treatment devices, if any installed.
2. Clean water strainer.
3. Check that the cabinet is level, in the side-to-side and front-to-back directions.
4. Clean the water system, evaporator plate and sump assembly, using a solution of SCOTSMAN Ice Machine Cleaner. Refer to CLEANING - Icemaker.

Cleaning requirements vary according to local water conditions and individual user operation. Continuous check of the clarity of ice cubes and visual inspection of the water system parts, evaporator plates and the sump assembly before and after cleaning will indicate frequency and procedure to be followed in local areas.

5. Check that the drain trough is snug on the evaporator plate.
6. Check and tighten all bolts and screws.
7. Check for water leaks and make corrections.
8. Check the bin thermostat control bulb to test shut off. Holding ice against bin thermostat control bulb should cause the icemaker to shut off at the end of the harvest cycle.

Within minutes after ice is removed from the bin thermostat control bulb, the icemaker will restart.

ICE STORAGE BIN

Clean and sanitize bin interior once per week.

CLEANING - Icemaker

//////////////////////////////////// **WARNING** //////////////////////////////////////

SCOTSMAN Ice Machine Cleaner contains Phosphoric and Hydroxyacetic acids. These compounds are corrosive and may cause burns. If swallowed, DO NOT induce vomiting. Give large amounts of water or milk. Call physician immediately. In case of external contact, flush with water. KEEP OUT OF THE REACH OF CHILDREN.

////////////////////////////////////

1. Remove front panel.
2. Switch the compressor switch to OFF.
Switch the master switch OFF.
3. Switch the master switch ON. Pour 8 ounces of Scotsman Ice Machine Cleaner into the sump filled with water.
4. Let the unit operate for 40 minutes with the compressor off, then switch the unit off.
5. Remove the front liner by removing 4 thumb screws. Remove the drain trough from one evaporator plate.
6. Switch on the master switch to pump water from the sump into the bin. Continue to add fresh water to flush residual cleaner from the system. Switch unit to OFF and wipe the sump clean.
7. Wash the plastic and stainless liners of the freezer section with a solution of household bleach and water. (1 ounce of bleach in 1 gallon of water.)
8. Replace the drain trough and the front liner.

CM450D MAINTENANCE & CLEANING INSTRUCTIONS

- 9. Turn the master and compressor switches back on.
- 10. Replace front panel.
- 11. Check each batch of cubes until they are clear and until the acid taste has been removed from the cubes.

- 12. Pour hot water into storage bin to melt the cubes and thereby clean the bin and drains with the same solution that has just cleaned the unit.
- 13. The unit is now ready for continued automatic operation.

//////////////////// **CAUTION** //////////////////////
DO NOT use ice cubes produced from the cleaning solution. Be sure none remains in the bin.
////////////////////////////////////

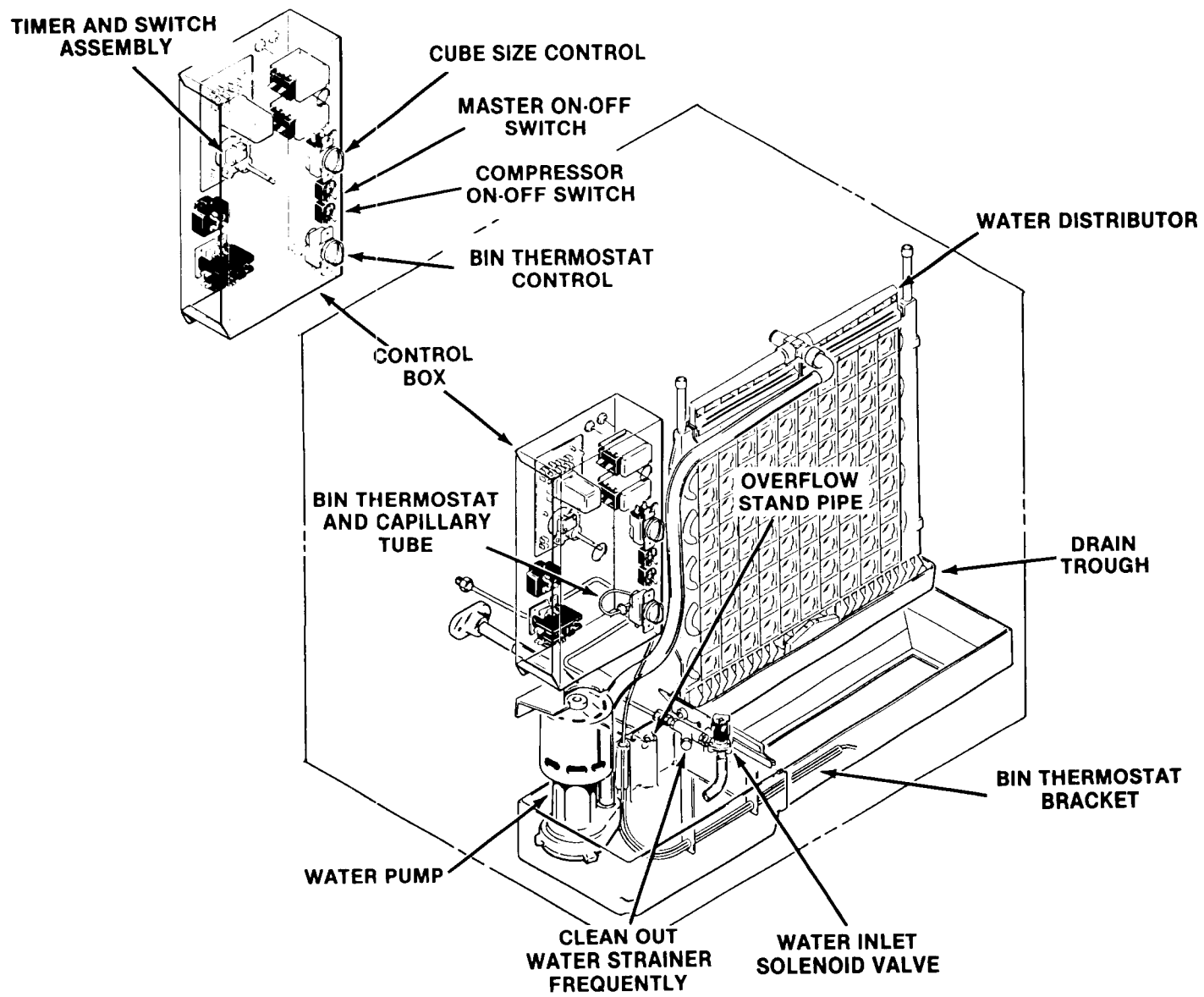

Cleaning Water System, Icemaker

CM450D COMPONENT DESCRIPTION

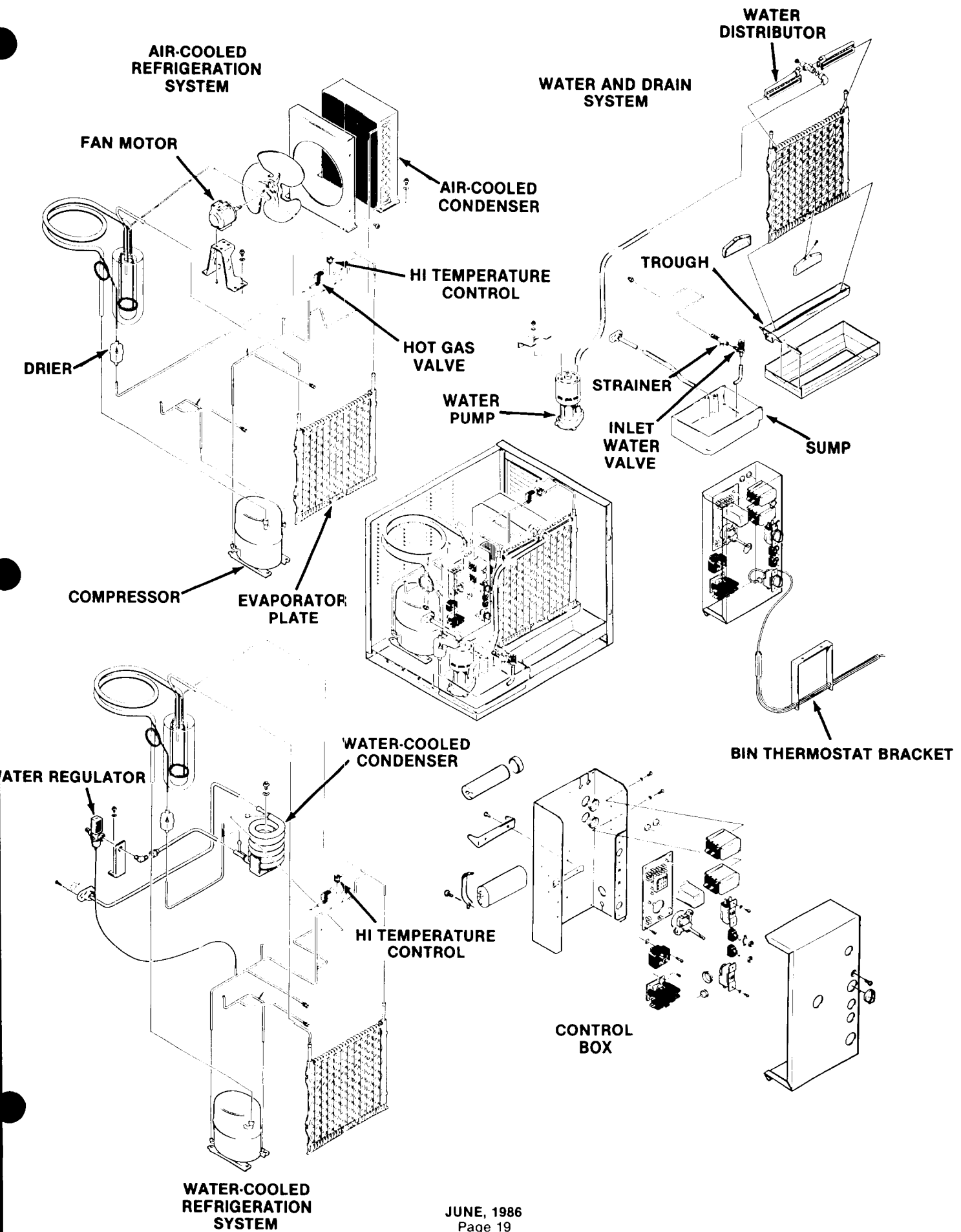

CM450D COMPONENT DESCRIPTION

BIN THERMOSTAT CONTROL

The bin thermostat is located on the front edge of the control box with an accessible knob on the front. The sensing capillary tube is routed from the control out the side of the control box down and across the front edge of the sump and down into the bin thermostat bracket. The bin thermostat control functions to automatically shut OFF the icemaker, when the ice storage bin is filled and ice contacts the capillary tube. It also signals the RESTART of the icemaker, when the capillary tube starts to warm up, after ice has been removed from the bin.

Bin thermostat control adjustment should ONLY be performed on icemakers installed in extreme warm or cold locations and adjust only in increments of one eighth turn at a time.

COMPRESSOR CONTACTOR

The compressor contactor functions to carry the compressor line current. The contactor is wired so any control in the pilot circuit, such as the bin thermostat, and high pressure controls, etc., will cause the contactor holding coil to be de-energized, when the control contact OPENS, thereby breaking the circuit to the compressor.

CUBE SIZE CONTROL

The temperature sensing cube size control affects the length of the freezing cycle prior to initiating the finishing timer. The cube size control closes its contacts when the evaporator reaches a preset temperature, starting the finishing timer. A variation in either ambient air or incoming water temperature will affect the efficiency of the refrigeration system. This will vary the length of time it takes the evaporator to reach the temperature at which the cube size control is preset to CLOSE; which, in turn, will affect the overall cycle time.

See *Cube Size Adjustment* BEFORE attempting to adjust the control.

RELAY

The multi-function, three pole, double-throw, plug-in relay is installed directly into a receptacle on the printed circuit board in the control box. The relay functions in part to by-pass the bin thermostat control to prevent the icemaker from shutting OFF, when a filled-bin condition occurs during the freezing cycle. The by-pass action serves to ensure full-sized ice cubes with each harvest cycle; and, to prevent short cycling on the bin thermostat control.

TIMER — Timer & Switch Assembly

The function of the timer begins when activated by the cube size control. The outer surface, or large diameter lobe of the timer cam, determines the timer cycle for finish freezing of the ice cubes, while the inner surface, or small diameter lobe, determines the time cycle for the harvest sequence. All electrical circuitry is connected through the printed circuit board and the timer and shunted by the single-pole, double-throw microswitch to either the freezing cycle or the harvest cycle. The microswitch is actuated by a cam assembly directly connected to the timer motor. The timer cam can be adjusted to vary the defrost line, as required. One complete rotation of the cam will take eight minutes. Harvest is preset at two and one-fourth minutes.

HIGH PRESSURE SAFETY CONTROL

This is a manual reset control that shuts down the icemaker, should the discharge pressure ever reach 450 PSIG on air-cooled and 350 PSIG on water-cooled.

CM450D COMPONENT DESCRIPTION

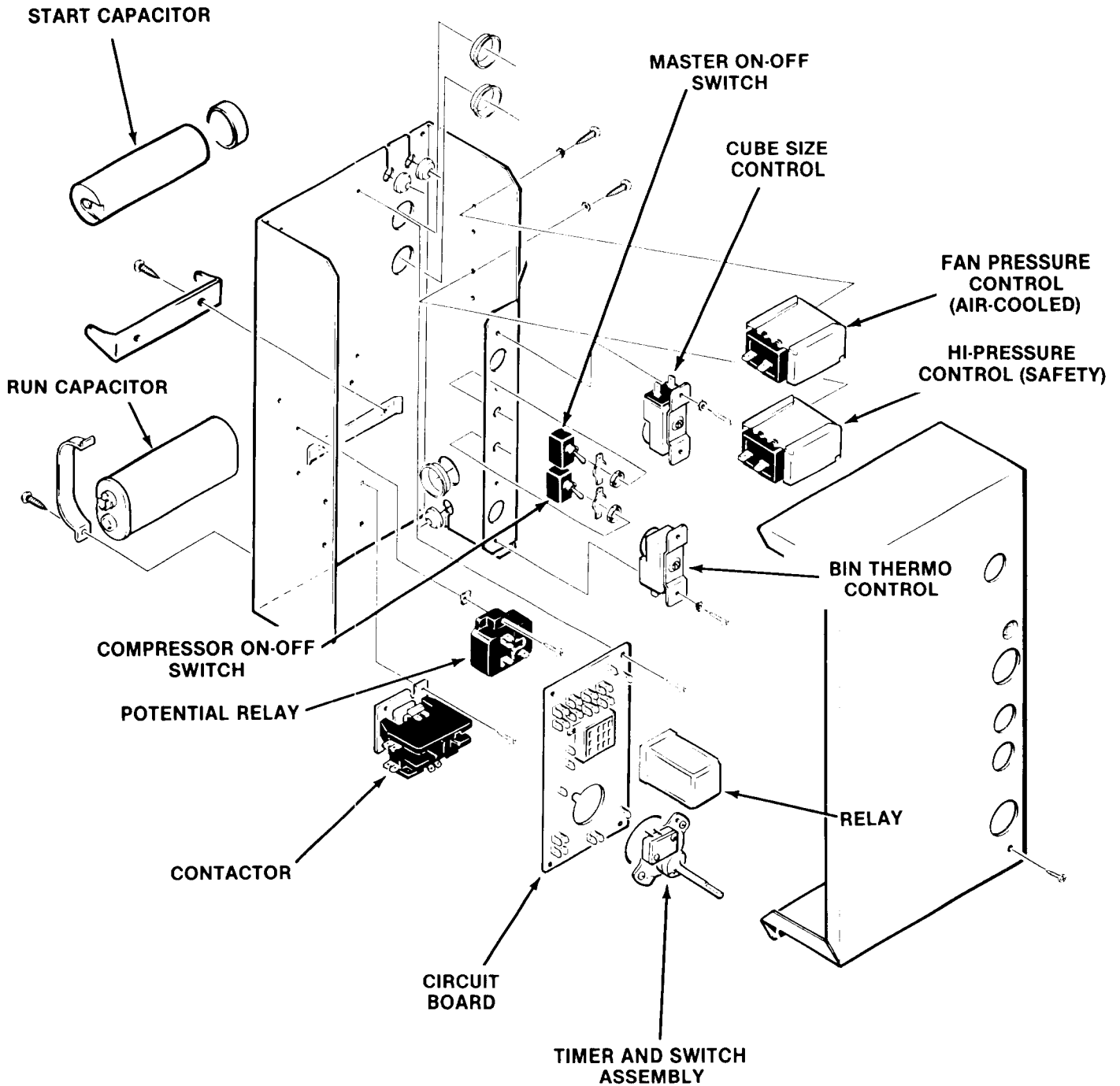

CM450D COMPONENT DESCRIPTION

WATER INLET SOLENOID VALVE

The water inlet solenoid valve functions to fill the sump assembly with water and overflow out the overflow standpipe located at the bottom of the sump. This action fills and rinses the sump during each harvest cycle. The flow rate is .75 g.p.m.

WATER REGULATOR VALVE -- Water-Cooled Model

The water regulator valve functions to maintain a constant compressor head pressure, by regulating the amount of inlet water flow through the condenser on water-cooled models. The valve operates through the refrigerant system high side pressure. Rotating the adjusting screw, located on top of the valve, can INCREASE or DECREASE the water flow through the water-cooled condenser, which in turn, will DECREASE or INCREASE the compressor operating head pressure. It is to be set at 220 PSIG.

When installing a replacement water regulator valve, be sure the replacement valve is installed with the arrow positioned in the direction of the water flow.

WATER DISTRIBUTION SYSTEM

The water distribution system functions to evenly supply water to all cells of the evaporator plates. The water pump pumps water from the sump up the vertical tygon tube to the tee. From there water is channeled through the water manifold to the water distributors, above each evaporator plate, and from six holes within each distributor, water flows to the cells of each side of the evaporator plates. Gravity flow returns the unfrozen excess portion of water to the sump reservoir for recirculation.

HOT GAS SOLENOID VALVE

The hot gas solenoid valve functions only during the harvest cycle, to divert the hot discharge gas from the compressor, bypassing the condenser and capillary tube, for direct flow in the evaporator plates to release ice cubes from the ice cube molds. The hot gas solenoid valve is comprised of two parts, the body & plunger and the coil & frame assemblies. Installed in the discharge line of the compressor, the energized solenoid coil lifts the valve stem within the valve body, to cause the hot discharge gas to be diverted when the finishing timer has advanced to the start of the harvest cycle.

FAN PRESSURE CONTROL — Air-Cooled Models only. In both freeze and harvest cycles, the fan pressure control functions to maintain a minimum discharge pressure by cycling the fan on and off. The approximate C.I. is 210 PSIG and C.O. is 193 PSIG.

STRAINER

A water strainer is located in the potable inlet water line before the water inlet solenoid valve. Clean the water strainer frequently.

CM450D COMPONENT DESCRIPTION

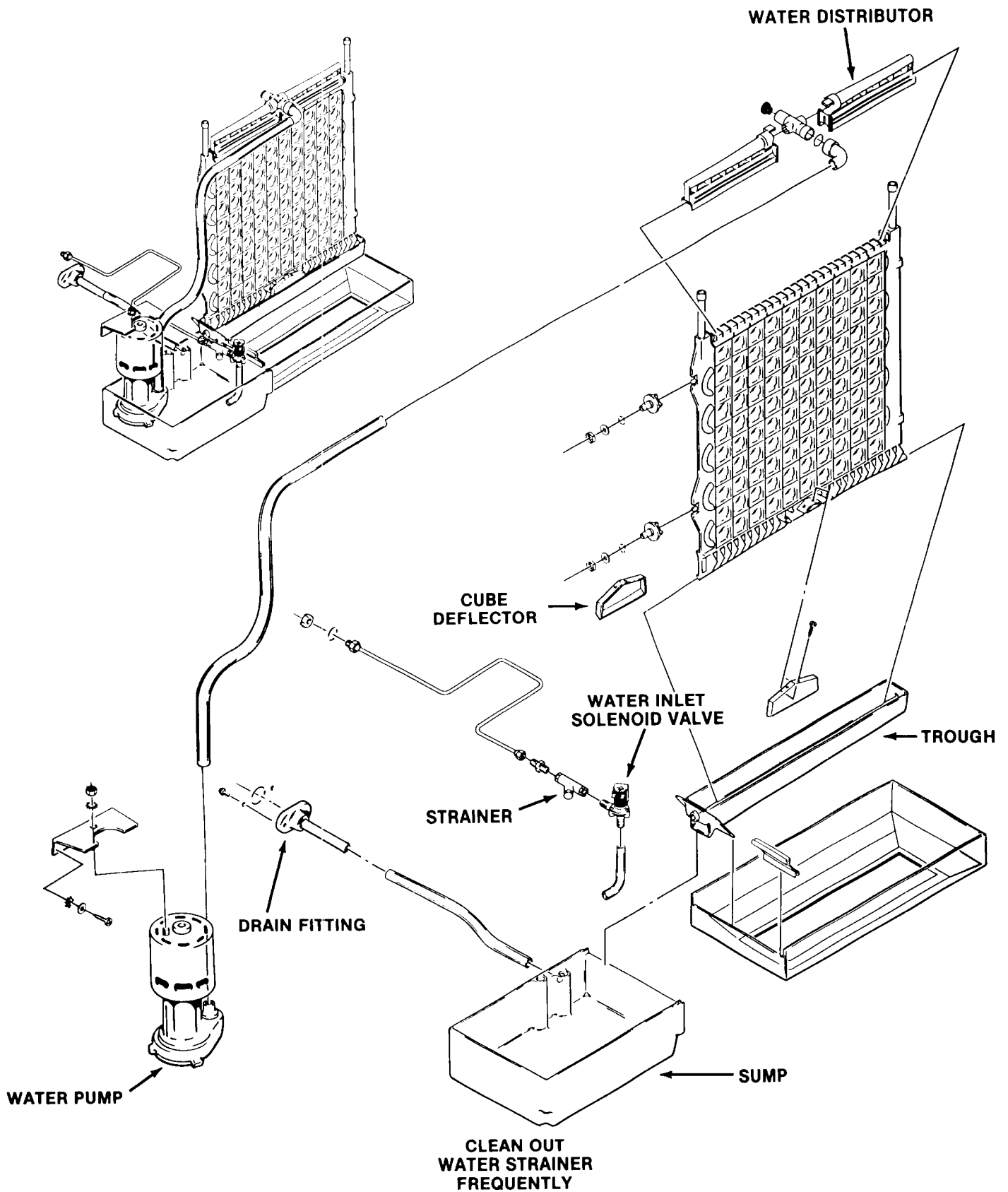

CM450D SERVICE DIAGNOSIS

The service diagnosis section is for use in aiding the serviceman in diagnosing a particular problem for pin-pointing the area in which the problem lies, thus an ever available reference for proper corrective action.

The following chart lists corrective actions for the causes of known symptoms of certain problems that can occur in the icemaking-refrigeration system.

ICEMAKING - REFRIGERATION SYSTEM

SYMPTOM	POSSIBLE CAUSE	CORRECTION
Irregular size cubes some cloudy.	Some distributor holes plugged	Clean distributor holes.
	Shortage of water.	Clean water sump. See shortage of water CORRECTION.
	Unit not level.	Level cabinet, as required.
Cubes too large.	Dirty air-cooled condenser.	Clean condenser.
	Cube size control set too cold.	Rotate cube size control dial toward WARMER.
Cubes too small.	Cube size control set too warm.	Rotate cube size control dial toward COLDER.
	Partially restricted capillary tube. (Kinked, pinched off, etc.)	Replace heat exchange assembly.
	Moisture in refrigeration system.	Blow refrigerant charge; replace drier; evacuate system; add proper refrigerant charge.
	Shortage of water.	See shortage of water CORRECTION.
Cloudy cubes.	Shortage of water.	See shortage of water SYMPTOM.
	Dirty water supply.	Check water quality and install water purification system.
	Accumulated impurities.	Use SCOTSMAN Ice Machine Cleaner and clean icemaker.
Shortage of water.	Short harvest cycle.	Adjust cam of timer and switch assembly.
	Water leak in sump area or off evaporator plate.	Locate Leak and correct condition.
	Partial restriction in water inlet strainer or inlet water valve.	Clean or replace strainer or valve.
	Water pressure too low.	Check for 20 PSI flowing water. Restore pressure.

CM450D SERVICE DIAGNOSIS

SYMPTOM	POSSIBLE CAUSE	CORRECTION
Decreased ice capacity.	High head pressure, result of dirty condenser or faulty fan motor or fan pressure switch or on water-cooled - not enough water through condenser.	Clean condenser. Repair or replace fan motor or switch. Check with regulator valve.
	Non-condensable gas in the system	Purge the system, evacuate and recharge per nameplate requirements.
	Poor air circulation or extreme hot location.	Relocate the cabinet; or provide ventilation.
	Overcharge of refrigerant.	Evacuate and recharge per nameplate.
	Hot gas solenoid valve leaking.	Replace valve.
	Partially restricted capillary tube.	See cubes too small CORRECTION.
Poor harvests. Icemaker does not harvest.	Defective compressor.	Replace compressor.
	Too short defrost time.	Check and adjust harvest cycle.
	Restriction in water inlet line.	Check strainer and inlet water valve.
	Hot gas solenoid does not open. Binds or burned out.	Replace solenoid, coil or valve as applicable.
	Undercharge of refrigerant.	Charge to nameplate requirements.
	Water pressure too low.	Check for 20 PSI flowing water. Restore pressure.
	Cube size too large or too small.	Adjust size with cube size control.
Water-cooled models: water Regulator valve leaks water thru during harvest.	Replace water regulator valve.	
Compressor cycles intermittently.	Low voltage.	Check for circuit overload. Check building supply voltage, if low, contact power company.
	Dirty condenser.	Clean condenser with vacuum cleaner or brush. DO NOT USE A WIRE BRUSH.
	Air circulation blocked.	Locate cabinet with adequate air space for proper air flow.
	Defective fan motor.	Replace fan motor.
	Non-condensable gases in system.	Purge the system and recharge per nameplate requirements.
Icemaker will not operate.	Blown fuse in line.	Replace fuse and check for cause.
	Master switch in OFF position.	Set switch to ON position.
	Faulty master switch.	Replace switch.
	Timer contacts open.	Replace timer microswitch.
	Faulty bin thermo.	Replace.
	Off on high head pressure safety switch.	Water-Cooled - water interruption correct. Air-Cooled - condenser not getting air.

CM450D ADJUSTMENT PROCEDURES

ADJUSTMENT OF THE BIN THERMOSTAT CONTROL

The control for the bin thermostat is the temperature control, located in the front of the control box.

The bin thermostat control requires adjustment only if the icemaker shuts off prematurely. Turn adjusting knob, in 1/8 turn or less increments, in the appropriate direction until the icemaker shuts OFF.

Remove ice from the capillary bulb; then, place warm hand on the capillary bulb to restart the icemaker.

Place handful of ice against the capillary bulb and observe that the icemaker should shut OFF. (Only at the end of harvest).

//////////////////// **CAUTION** //////////////////////

The adjusting screws on the temperature control device have very sensitive response to adjustment. DO NOT attempt to adjust the screw until after thoroughly reading and understanding the instructions and illustrations. Over-adjusting or erratic guessing, can foul the instrument and cause ultimate delay and part replacement, WHICH COULD HAVE BEEN PREVENTED.

////////////////////////////////////

ALTITUDE ADJUSTMENT over 2,000 feet above sea level only

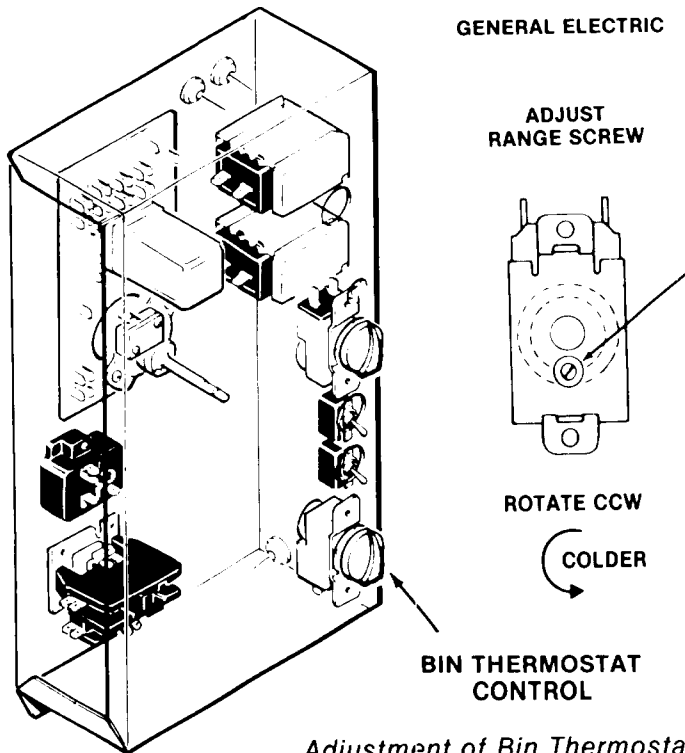

Adjustment of Bin Thermostat

ADJUSTMENT OF THE WATER REGULATOR ASSEMBLY — WATER-COOLED MODELS

The correct compressor head pressure on water-cooled models is 220 PSIG. Adjusting the water regulator valve increases or decreases the rate of flow of water, through the water-cooled condenser; which increases or decreases the affected temperature/pressure of the compressor head pressure, INCREASED water flow, results in DECREASED or LOWER head pressure; while, DECREASED water flow, results in INCREASED or HIGHER head pressure.

To adjust the water regulator assembly:

To INCREASE the head pressure: Rotate the adjusting screw COUNTERCLOCKWISE.

To DECREASE the head pressure: Rotate the adjusting screw CLOCKWISE.

Check change in compressor head pressure, and repeat adjustment as necessary, to achieve desired operating head pressure.

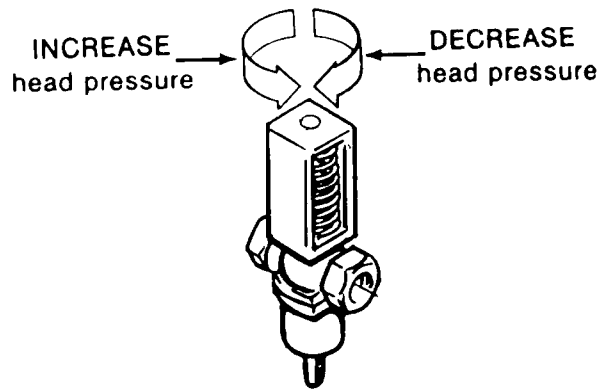

WATER REGULATOR

CM450D ADJUSTMENT PROCEDURES

ADJUSTMENT OF THE CUBE SIZE CONTROL

CAUTION

BEFORE performing actual adjustments to the cube size control, check other possible causes for cube size problems, refer to SERVICE DIAGNOSIS for problem review and analysis. DO NOT perform adjustment when a new cube size control is installed, until the control bulb has been properly installed in the tube well, on the evaporator outlet tube and the icemaker has progressed through several complete freezing and harvest cycles, to observe size and quality of ice cubes freezing and harvest cycles, and whether or not a cube size problem exists.

As a reverse acting temperature control, adjustment on the cube size control is performed to cause either larger sized ice cubes or smaller sized ice cubes to be produced.

To produce LARGER sized ice cubes:

1. Locate the cube size control, on the front of the control box.
2. Rotate the adjusting knob one-eighth of a turn CLOCKWISE toward COLDER.
3. Observe size of ice cubes in next two ice cube harvests and repeat step 2 above, in one-eighth turn increments, until correct ice cube size is achieved.

To produce SMALLER sized ice cubes:

1. Locate the cube size control, on the front of the control box.
2. Rotate the adjusting knob one-eighth of a turn COUNTERCLOCKWISE toward warmer.
3. Observe size of ice cubes in next two ice cube harvests and adjust in one-eighth turn increments, until correct ice cube size is achieved.

ADJUSTMENT OF THE TIMER & SWITCH ASSEMBLY

The timer and switch assembly is factory set, so one complete revolution of the cam on the timer represents eight minutes. Five and one-half minutes comprise the freezing cycle event during cam rotation, and the final two and one-half minutes program the defrost and harvest cycle. Rotating the shaft of the timer cam CLOCKWISE will allow positioning the actuator arm of the microswitch on the cam at the selected start position for either the freezing cycle or harvest cycle, as required in the cleaning instructions.

WARNING

Disconnect electrical power supply to icemaker whenever adjustment procedures are performed.

To adjust the timer & switch assembly:

- A. HARVEST CYCLE: Slowly rotate the shaft of the timer and switch assembly, located in the control box, CLOCKWISE, until the actuator arm on the microswitch initiates the harvest cycle. An audible click can be heard, but in a noisy area, look at the cam and switch to observe the event.
- B. FREEZING CYCLE: Slowly rotate the shaft of the timer and switch assembly, located in the control box, CLOCKWISE, until the actuator arm on the microswitch initiates the freezing cycle.
- C. The length of the harvest cycle can be changed by loosening the adjustment screw on the cam. The normal setting is two and one-quarter minutes, as set at the factory. It is important that the length of the harvest cycle allow enough time for all the ice cubes to fall from the evaporator. Too short of a time will cause the evaporator to freeze up and stop ejecting ice into the bin. Too much time wastes icemaking capacity, energy and water. Adjustment of the harvest cycle may require a corresponding adjustment of the cube size control.

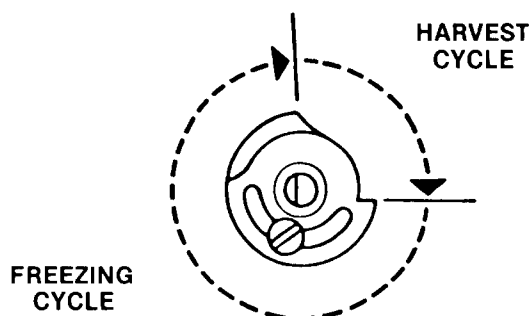
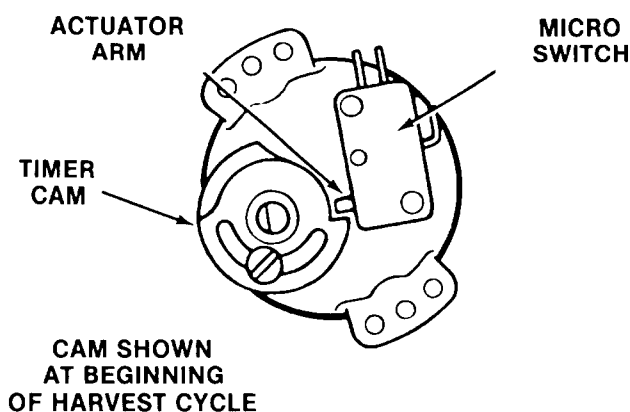

CM450D REMOVAL AND REPLACEMENT PROCEDURES

//////////////////// WARNING //////////////////////////////////////

Be sure the electrical power supply circuit breaker and the inlet water supply are OFF, BEFORE starting any of the following REMOVAL AND REPLACEMENT procedures as a precaution to prevent possible personal injury or damage to equipment.

////////////////////////////////////

REMOVAL AND REPLACEMENT OF THE DRIER

To remove the drier:

1. Pull out to unsnap catches and remove the front panel.
2. Remove screws and remove left side access panel.
3. Bleed off or blow the refrigerant charge through the Schrader valve.
4. Unsolder refrigeration lines at both ends of the drier, and remove the drier.

To replace the drier:

//////////////////// CAUTION //////////////////////////////////////

If the factory seal is broken on the replacement drier, exposing it to the atmosphere more than a few minutes, the drier will absorb moisture from the atmosphere and lose substantial ability for moisture removal.

Be sure the replacement drier is installed with the arrow positioned in the direction of the refrigerant flow.

////////////////////////////////////

1. Remove the factory seals from the replacement drier and install the drier in the refrigerant lines with the arrow positioned in the direction of the refrigerant flow.
2. Solder the drier into the lines, two places, taking precautions to NOT OVERHEAT the drier body, during installation soldering.
3. Purge the system and check for leaks.
4. Thoroughly evacuate the system to remove moisture and non-condensables.
5. Charge the system with refrigerant, by weight. SEE NAMEPLATE.
6. Replace and attach the left side panel.

//////////////////// NOTE //////////////////////////////////////

Always install a replacement drier, anytime the sealed refrigeration system is opened. Do not replace the drier until all other repair or replacement has been completed.

REMOVAL AND REPLACEMENT OF THE EVAPORATOR PLATE ASSEMBLY

1. Remove the front and top panels.
2. Bleed off or blow the refrigerant charge through the Schrader valve.
3. Disconnect Tygon water inlet tube(s), at the water manifold tee(s), above the evaporator plates.
4. Unsnap the sump assembly from the lower left and right attachment points on each evaporator plate.
5. Slide the water distributor tubes about 1/8-inch along the top of the evaporator plate to be removed, until the left water distributor tube can be lifted upward.
6. Lift the end of the water distributor tube and slide the distributors toward the left along the top of the evaporator plate, until the flexible right notch is cleared.
7. Unsnap and disconnect each left and right water distributor tube from the water manifold section.

//////////////////// CAUTION //////////////////////////////////////

Use EXTRA PRECAUTION to protect the plastic parts during the next step to unsolder the refrigerant lines, two places, at the top of the evaporator plate. Position wet cloths over top of plates, as well as over the plastic liner at the rear, or sides, to prevent accidental heat damage, or possible fire from torch flame.

////////////////////////////////////

8. Unsolder and remove the refrigerant lines at the top of the evaporator plate to be replaced.
9. Remove nuts at left of the evaporator then, loosen the braces just enough to remove the evaporator plate. Temporarily replace the braces, to support the remaining evaporator plate.

To replace the evaporator plate, reverse the removal procedures. See Nameplate. Weigh in proper charge of R-502.

CM450D REMOVAL AND REPLACEMENT PROCEDURES

REMOVAL AND REPLACEMENT OF THE COMPRESSOR ASSEMBLY

To remove the compressor assembly:

1. Pull out to unsnap catches and remove the front panel.
2. Remove screws and remove cabinet top and left side access panel.
3. Bleed off or blow the refrigerant charge through the Schrader valve.
4. Remove the cover from the terminal box on the compressor; then, remove electrical leads from the compressor.
5. Unsolder suction, discharge and process header from compressor.
6. Remove four bolts and washers which secure the compressor to the chassis mounting base.
7. Remove the compressor from the cabinet.

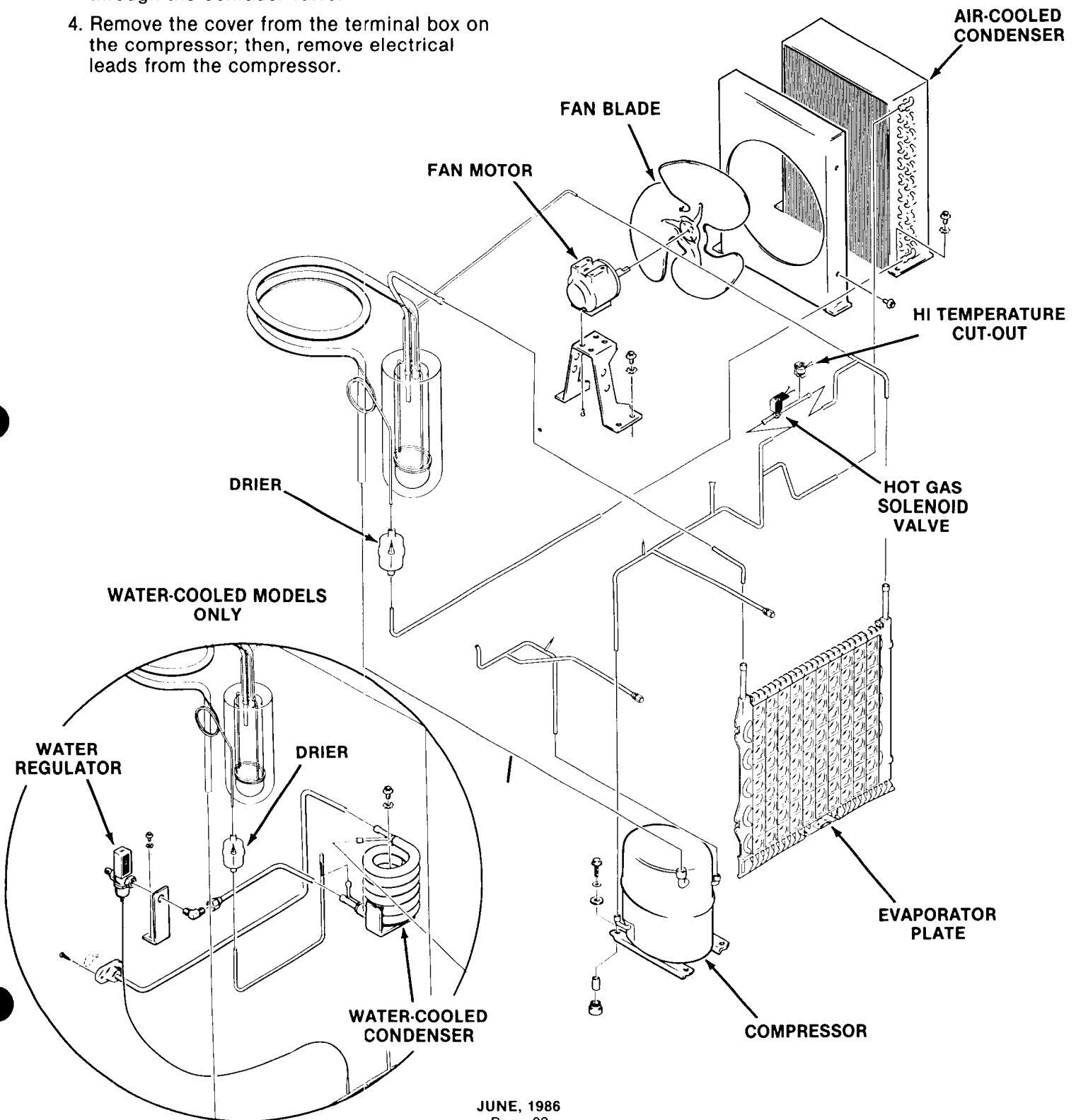

CM450D REMOVAL AND REPLACEMENT PROCEDURES

////////// WARNING //////////

Disconnect electrical power supply to icemaker whenever adjustment procedures are performed.

////////////////////////////////////

REMOVAL AND REPLACEMENT OF THE CONDENSER — AIR-COOLED MODELS

To remove the condenser:

1. Pull out to unsnap catches and remove the front panel.
2. Remove screws and remove cabinet top and right service side panels.
3. Bleed off or blow the refrigerant charge through the Schrader valve.
4. Unsolder and disconnect refrigerant lines from the condenser.
5. Unsolder and remove the drier from the refrigerant lines connecting to the condenser.
6. Remove screws, lockwashers and the condenser from the chassis base.

To replace the air-cooled condenser, reverse the removal procedure.

REMOVAL AND REPLACEMENT OF THE CONDENSER — WATER-COOLED MODELS

To remove the condenser:

1. Remove screws and the right side panel.
2. Bleed off or blow the refrigerant charge through the Schrader valve.
3. Check to be sure building source water inlet supply shutoff valve to rear of chassis is OFF.
4. Disconnect water-cooled condenser inlet water line at the water regulator assembly outlet fitting.
5. Unsolder the refrigerant capillary tube distributor line at the outlet end of the drier, the refrigerant liquid line from the bottom of the condenser, and remove the drier from the lines.
6. Unsolder the compressor discharge line, at the top of the water-cooled condenser.

7. Unsolder the compressor discharge line at the top of the water-cooled condenser and the refrigerant line from the bottom of the water regulator valve.
8. Remove two screws and washers and the water-cooled condenser from the cabinet.

To replace the water-cooled condenser, reverse the removal procedures.

REMOVAL AND REPLACEMENT OF THE FAN MOTOR — AIR-COOLED MODELS

To remove the fan motor assembly:

1. Pull out to unsnap catches and remove the front panel.
2. Remove unit top or left side panel.
3. Disconnect the two electrical leads, from the fan motor, at the control box assembly.

Before next step, measure or make accurate mental note of the distance the fan blades extend beyond the fan shroud, so during replacement the correct distance is maintained.

4. Remove screws and the fan motor and bracket assembly; and remove the fan motor and bracket from the chassis base.
5. Loosen set screws on the fan blade and remove the fan blade from the fan motor. Mark or note position of the blade on the shaft of the fan motor, for replacement.
6. Remove screws and lockwasher and separate the fan motor from the fan motor bracket.

To replace the fan motor assembly, reverse the removal procedure.

Be sure to replace the fan blade with the hub of the fan blade facing the fan motor, to ensure air flow is toward the fan motor; and, is set at marked location on shaft and setscrews tightened on the FLAT part of the shaft of the fan motor.

////////////////////////////////////

Always install a replacement drier, anytime the sealed refrigeration system is opened. Do not replace the drier until all other repair or replacement has been completed.

NOTE

////////////////////////////////////

Thoroughly evacuate the system to remove moisture and non-condensables.

CM450D REMOVAL AND REPLACEMENT PROCEDURES

//////////////////// WARNING //////////////////////

Disconnect electrical power supply to icemaker whenever adjustment procedures are performed.

////////////////////////////////////

REMOVAL AND REPLACEMENT OF THE CUBE SIZE CONTROL

To remove the cube size control:

1. Remove front panel.
2. Remove cover from control box.
3. Trace capillary tube, from the cube size control to the refrigerant suction line.
4. Remove the coiled capillary tube bulb from the tube well on the suction line.
5. Remove electrical leads from the cube size control.
6. Remove screws and the cube size control.

To replace the cube size control, reverse the removal procedure.

REMOVAL AND REPLACEMENT OF THE WATER DISTRIBUTOR TUBES AND MANIFOLD TUBES

To remove the water distributor tube and manifold tube:

1. Pull out to unsnap catches and remove the front panel.
2. Remove 4 thumb screws and remove the evaporator cover.
3. Slide the water distributor tube to the left about 1/8-inch along the top of the evaporator plate, until the water distributor tube can be unsnapped from the flexible notch and lifted upward to the right side.
4. Unsnap and disconnect water distributor tubes from the water manifold section.

To replace the water distributor tubes and manifold tubes, reverse the removal procedure. BE SURE the notches in the water manifold tubes properly engage the alignment keys in the tee.

BE SURE the water distributor tube is securely fastened at the notch at both sides of the evaporator plate.

Check identical attachment for the left water distributor tube and notch; also, that the distributor/manifold connections at the top center of each evaporator plate is snug against the top of the plate.

REMOVAL AND REPLACEMENT OF THE BIN THERMOSTAT CONTROL

To remove the bin thermostat control:

1. Remove front panel.
2. Remove screws and the control box cover.
3. Remove wire leads from the bin thermostat control.
4. Unthread the capillary tube and remove from the bin thermostat control bracket at the bottom right side of the evaporator section.
5. Remove the two screws attaching the bin thermostat control to the side of the control box; then, carefully pull the capillary tube out of the evaporator section. Carefully remove the bin thermostat control and capillary tube from the control box.

To replace the bin thermostat control, reverse the removal procedure.

REMOVAL AND REPLACEMENT OF THE INLET WATER SOLENOID VALVE ASSEMBLY

To remove the inlet water solenoid valve assembly:

1. Shut OFF water supply to machine.
2. Remove screws and pull the water solenoid valve out to gain access.
3. Loosen and remove inlet water line fitting from the inlet water solenoid valve assembly.
4. Remove inlet water Tygon tubing from the water solenoid valve.

To replace the inlet water valve assembly, reverse the removal procedures.

//////////////////// NOTE //////////////////////

Always install a replacement drier, anytime the sealed refrigeration system is opened. Do not replace the drier until all other repair or replacement has been completed.

CM450D REMOVAL AND REPLACEMENT PROCEDURES

//////////////////// WARNING //////////////////////////////////////

Disconnect electrical power supply to icemaker whenever adjustment procedures are performed.

////////////////////////////////////

REMOVAL AND REPLACEMENT OF THE WATER PUMP ASSEMBLY

To remove the water pump assembly:

1. Pull out to unsnap catches and remove the front panel.
2. Remove the Tygon tube to the pump assembly.
3. Disconnect electrical leads from the water pump assembly.
4. Loosen thumbscrew, loosen Phillips headscrew, lift pump up and remove from unit.

5. Remove one nut and mounting bracket from top of water pump.

To replace the water pump assembly, reverse the removal procedure.

