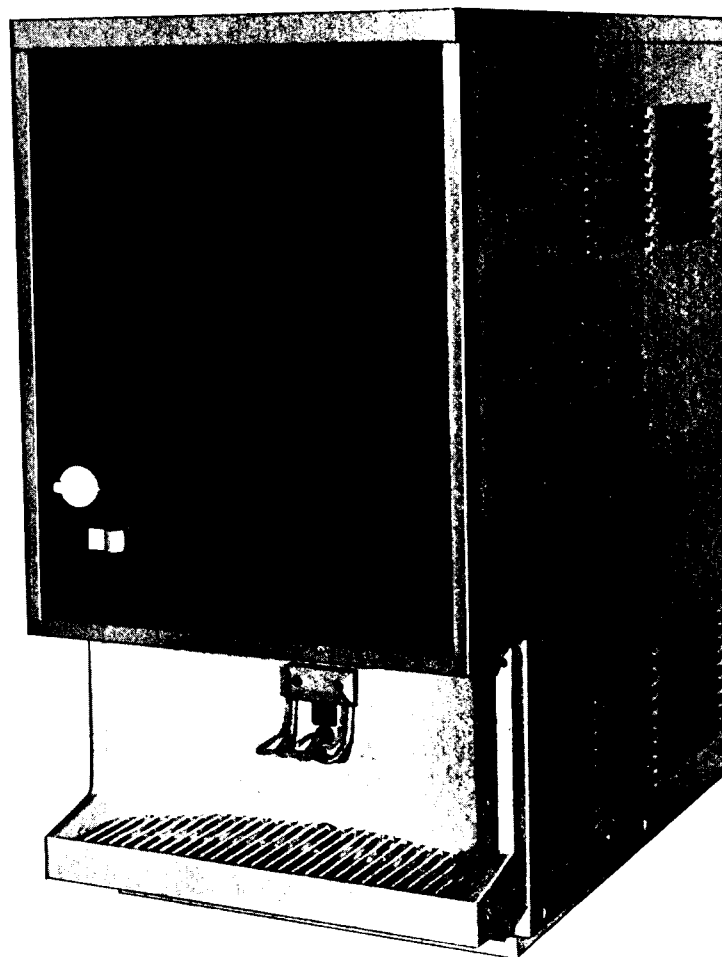

TABLE OF CONTENTS

Foreword	1
Table of Contents	2
Photo and Ice Making Capacity	3
Specifications	4-5
General Description	6
General Information	7
Installation Instructions	8-9-10
Ice Dispenser Control System	11
Adjustment of Controls	12-13-14
Shutter and Bin Adjustment	15
Storage Bin and Dispensing Assy.	16
Bin Controls	17
Storage Bin Top Assy.	18
Dispenser Control System	19-20
Wiring Diagram	21
Reservoir Assy	22
Cabinet Panels-Chassis	23
Chassis Assembly	24-25
Gear Motor Assembly	26
Freezer Assembly	27
Service Analysis (Icemaker)	28-29
Service Analysis (Dispensing Mechanism)	30
Maintenance Instructions (Flaker)	31
Cleaning Instructions	32
Accessory Kits	33-34

**THIS PAGE
INTENTIONALLY
LEFT BLANK**

**THIS PAGE
INTENTIONALLY
LEFT BLANK**



FD3 SERIES ICEMAKER- DISPENSERS

ice making capacity

Daily Ice Capacity is directly related to condenser air inlet temperature, water temperature and age of machine.

NOTE: To keep your SCOTSMAN DISPENSER performing at it's maximum capacity it is necessary to perform periodic maintenance as outlined on page 32 of this manual.

SPECIFICATIONS

FD3 SERIES ICEMAKER-DISPENSER

CABINET

Height	28.3 inches
Depth	23.8 inches
Width	14.3 inches
Weight	150 pounds
Finish	Baked-On Enamel or stainless steel
Trim	Aluminum, anodized
Sink & Drain	Plastic

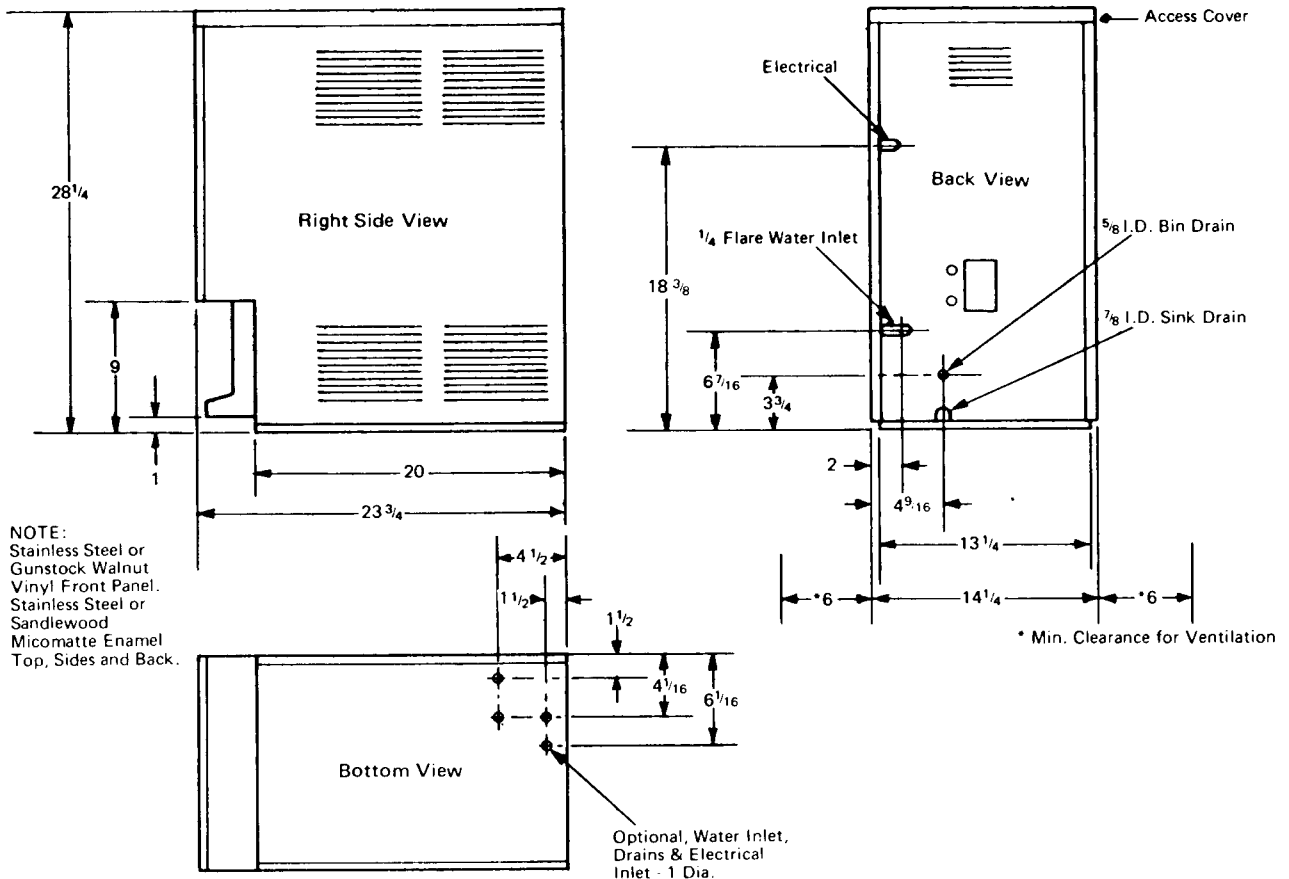

NOTE: Available with: Wall Mounting Kit
Sink Extension Kit

SPECIFICATIONS

REFRIGERATION UNIT

Compressor Tecumseh
1/5 H.P.
2 pole
115 v. 60 cycle
Freezer SF-75 Modified
Refrigerant R-12—10 oz. charge
Ice Produced04 oz. sec. (70° ambient, 70° water)
(approximate)

DISPENSING UNIT

Bin & Dispensing Cylinder Stainless Steel
Insulation 1 inch Urethane
Storage Capacity 8.19 pounds
Ice Spout Composition (rubber)
Drive Motor 86.5 watt
115 v. 60 cycle
R.P.M. 26.7
Dispensing Rate8 oz. sec.
(approximate)

PERFORMANCE DATA

Metered Ice-per vend 1 or 2 oz.
Time per vend 1.5 sec.
1 vend /31 sec. Recovery=Discharge
Water with minimum ice 1.0 oz. ice water
Water with maximum ice 2.0 oz. ice water
Dispensing time (ice & water
for 10 oz. glass) 4.5 sec.
Continuous ice flow 1 pound in 20.8 sec.

GENERAL DESCRIPTION

This unit is a counter or table-top type of dispenser with a self-contained refrigeration unit, flaked ice freezer, storage bin and automatic dispensing mechanism.

The primary purpose of this machine is to fill water or drink glasses with water and ice or just ice by actuating a control arm with the glass.

Approximately one or two ounces or a continuous flow of ice can be obtained by properly adjusting a selector switch. By pushing a water switch to "on" water will be dispensed with the ice or as long as the glass actuator arm is energized.

The sink or area in which the ice is dispensed is constructed of plastic. The drain grill is 100% nylon coated steel wire. The cabinet is of stainless steel or steel with a baked-on enamel finish. Water lines within the cabinet are of copper or nylon and drain lines are tygon (plastic) tubing.

The complete machine has been designed with sanitation and ease of cleaning emphasized. The storage bin is sealed and the ice spout is automatically closed when ice is not being dispensed. The complete dispensing unit can be dismantled for cleaning without the need of tools. By removing two winged screws the cabinet top can be removed. Three winged bolts on the storage bin cover may be loosened and the cover can be lifted off. This exposes the entire dispensing mechanism which can be lifted out of the storage bin.

The base of the machine contains a sealing gasket which will seal the machine tight against the table or counter top, thereby, eliminating the possibility of dirt or bugs lodging under the base.

The top, back, front, sink or either side of the cabinet can be removed in a matter of minutes.

To clean the condenser or for access to the control box, the left side panel is removed.

GENERAL INFORMATION

1. The machine comes to you ready to operate except for water, electrical power and drain connections.
2. The attached information on adjustments should not be needed except in rare instances.
3. An interlock switch, located on the top frame, is held in an "on" position when the cabinet top cover is in place. When the cover is removed the power to the machine is automatically disconnected for cleaning. For electrical service the main power supply should be disconnected.
4. The unit should not be connected to a heavily fused supply line. Maximum fusing should be not more than 15 amperes. It is advisable to use a fustat, fusetron or delay type of fuse.
5. All parts of the unit can be washed with mild soap and water. This includes the stainless steel and paint parts. Care must be exercised in handling the cleaning of the various stainless steel pieces as these parts have a tendency to be more sharp at the edges than painted parts.
6. Because of the various electrical controls and wiring, care must be used in grounding this cabinet and frame work to a solid cold water line or similar ground.
7. The FD3 and FD4 are identical in outward appearance with the case assembly on. For identification purposes a decal is placed on the back panel. When a screw head appears in the upper hole it identifies the FD3 and in the lower hole the FD4.

INSTALLATION INSTRUCTIONS

1. Remove the unit from the carton and install on a table or counter with a flat, level, rigid top. Mount at a convenient height for filling glasses.
2. Avoid sliding the unit on the rubber sealing base.
3. Remove the top of the cabinet and the rear panel. Remove packing from float chamber.
4. Pull the drain from the cabinet. This may be routed through the rear panel through the hole provided in the base. It is possible to route all lines through holes which have been provided in the base.
5. The lower drain from the sink area must never be installed higher than the base of the cabinet. Consideration should be made in regard to this drain in order to get proper flow from the sink drain.
6. Water should be supplied from a 3/8" copper or equivalent pipe. Too small a water supply line will only result in an increase in time for filling glasses with water.
7. Connect power to lower terminal strip in junction box.
8. The interlock switch located at the top of the cabinet frame will be in an "ON" position when the cover is on the cabinet.
9. Replace the rear panel and the cabinet cover. The switch is used only when the machine is opened for cleaning. At such a time both the unit and dispenser are disconnected by removing the cover.
10. Thirty minutes after the unit has been started, ice can be dispensed.

NOTE: Should this unit be improperly installed with the drain favoring front of the machine, a condition would result in slushy, wet ice as the meltage water would remain in the bottom of the storage bin, and may run out the discharge spout.

WARNING: THIS MACHINE MUST NOT BE ALLOWED TO OPERATE WHEN THE WATER SUPPLY IS SHUT OFF, OR AT BELOW RECOMMENDED WATER PRESSURE. TURN MASTER SWITCH TO "OFF" POSITION WHEN WATER SUPPLY IS OFF, OR WHEN WATER PRESSURE IS BELOW RECOMMENDED OPERATING PRESSURE.

INSTALLATION PRACTICE

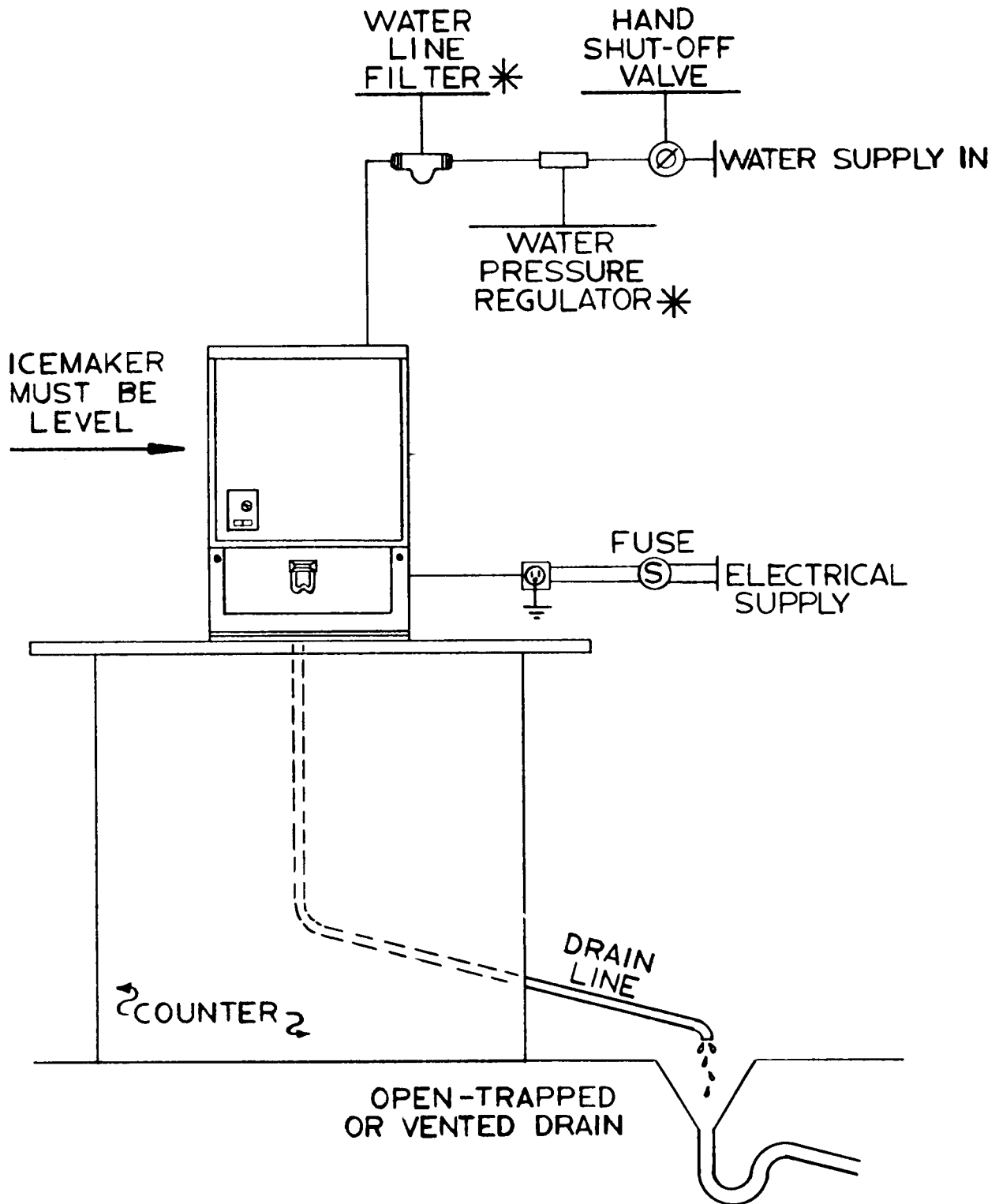

* REGULATOR AND FILTER ARE ACCESSORY ITEMS
TO BE INSTALLED AS CONDITIONS WARRANT

HOOK-UP SPECIFICATIONS

ELECTRICAL:

Standard electricals are 115 volts, 60 cycle single phase current. Use No. 12 gauge wire, either in three wire cords rubber covered or thermoplastic types that incorporate a ground wire as the third wire. This unit must have a solid ground wire.

Major electrical components	H.P. Size	Amps.
1. Refrigerant Compressor	1/5	3.6
2. Freezer Gearmotor	1/15	2.2
3. Dispensing Drum Motor	1/25	2.35
TOTAL		10.15

15 amp fuse protection is required, preferable a delay type such as Fustat, Fusetron etc. All external wiring should conform to National Underwriters, as well as State and local codes. The maximum allowable voltage variation must not exceed 10 per cent of unit nameplate ratings, even under starting conditions.

Knockouts in cabinet are made for cord connectors. Supply line ties into lower terminal board of control box. Use separate circuit for icemaker only.

WATER SUPPLY:

A single cold water supply line is required. Recommended tubing size 3/8" O.D. or larger, cabinet connection is to a 1/4" S.A.E. flare tee (item No. 13 on page 26) on internal cabinet bulkhead. A water strainer with clean out feature should be installed in supply line along with a hand shut off valve.

Minimum water pressure is 20 pounds gauge, maximum pressure over 50 pound gauge may cause chattering of float ball in reservoir tank. For pressures in excess of 50 pounds, use a water pressure regulator in line. Cabinet back is slotted for supply line entrance.

WATER AND CONDENSATE DRAINS:

Two soft drains (plastic tubing) are provided, see page 24. The upper drain is 5/8" I.D. tubing, the lower drain is 7/8" I.D. tubing. Drain lines should be run to an open, trapped or vented drain in accordance with your State and local code regulations. These are gravity drains, therefore maintain at least a 1/4" pitch per foot away from unit drains. Knockouts are provided for either out the back or thru the base drain.

REFRIGERANT SYSTEM:

The standard Scotsman Flaker system is used in slightly modified form. Refrigerant 12 is pumped by compressor into the air cooled condenser, into the liquid line, thru a filter-drier and then into the capillary refrigerant control line.

Liquid refrigerant is then carried down to the bottom end of the shell and tube type evaporator (freezing cylinder) where it expands and rises to the top of evaporator. Here the vapors and gasses are returned thru an accumulator and suction line to the compressor.

Average operating head pressure is 135 lb. gauge, operating back pressure is 14 lb. gauge. Factory charge is 10 ounces of Refrigerant 12.

Compressor is 1/5 horsepower, 2 pole, 3500 RPM by Tecumseh. Proper model number is Tecumseh AE59ZF9-46.

ICE DISPENSER CONTROL SYSTEM

The inner storage bin rotates, carrying the ice over a cutting edge located at the ice discharge spout. The ice is thereby cut off the bottom of the stored mass and falls down the spout.

When the selector switch is set at 1 oz. of ice, the dispensing bin will rotate 1/2 turn for each vend. When the selector switch is set at 2 oz. of ice, the dispensing bin will rotate one full turn.

The action is controlled by two switches mounted together with their rollers riding on a cam. They are located on the bin cover and under the drive motor bracket, see page 18. The cam has one depression for the top switch roller to fall into and two for the bottom switch roller. The top switch controls the 2 oz. vend in which the bin rotates one full turn to actuate the switch. The lower switch controls the 1 oz. vend for 1/2 a turn of the bin.

At the end of each vend it is necessary that the dispensing bin stop in the correct position. It must stop at such a time as the spout shutter, item No. 6 on page 16, which rotates with the bin, is directly over the spout. It is also at this time that one of the fins in the rotating bin is in the center and directly under the flaker freezer spout. When this timing is correct, ice that is filling the bin from the freezer will fall in both compartments of the bin; that is, on both sides of the fins. Also, by this timing the ice discharge spout is closed, which not only tends to keep dirt from entering the bin, but also sheds meltage from the bin away from the discharge spout.

The selector switch also has a continuous flow position in which ice will continue to vend as long as the control arm is held in. When released the top switch on the cam will position the shutter over the spout.

When the water switch is in an "ON" position, water will be dispensed with the ice. Water will always continue to flow as long as the actuating arm is held "IN". See page 13 for a simplified circuitry showing the operation of these switches.

CONTROL SWITCHES & CAM

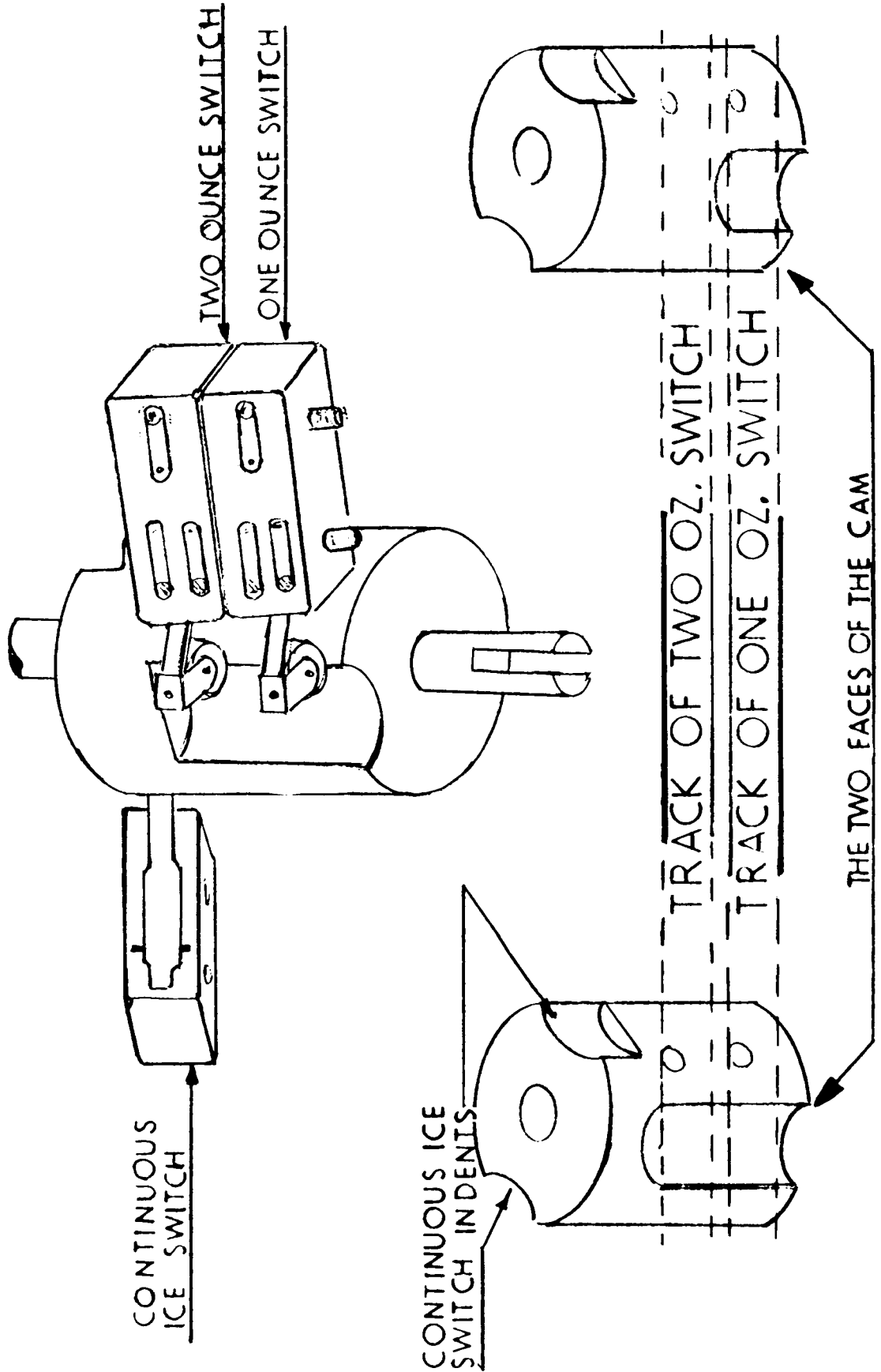

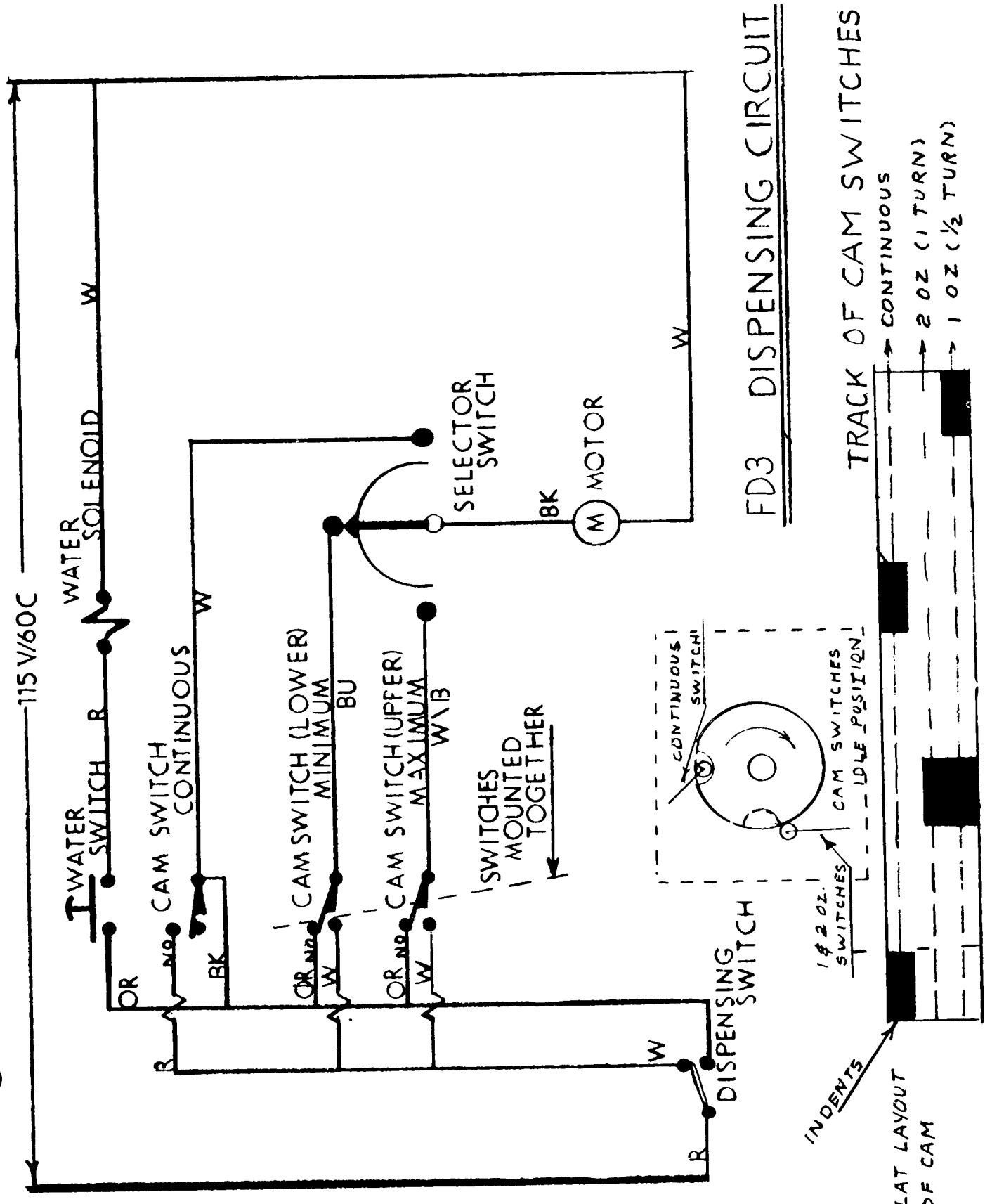

FD3 DISPENSING CIRCUIT

TRACK OF CAM SWITCHES

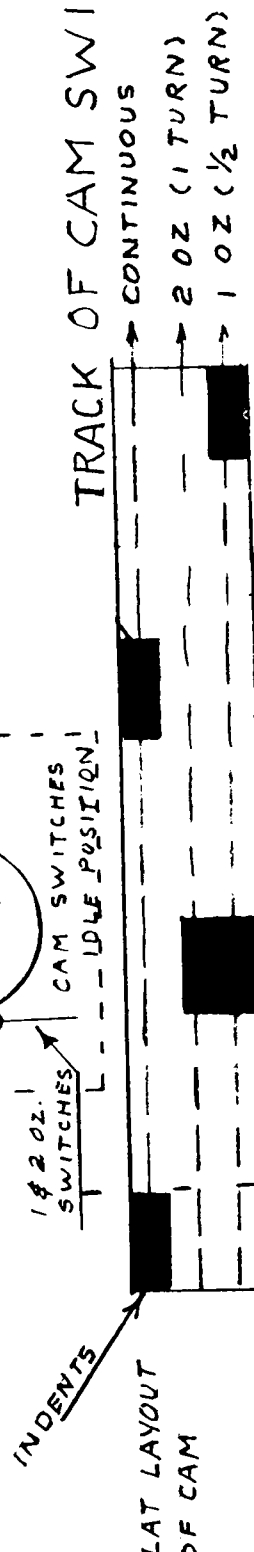

INSTRUCTIONS FOR SETTING CAM SWITCHES WHEN DISPENSER WILL NOT STOP OR WILL NOT DISPENSE PROPERLY. (DO NOT ADJUST CAM SWITCHES UNTIL YOU ARE SURE DISPENSER MECHANISM RUNS FREELY.)

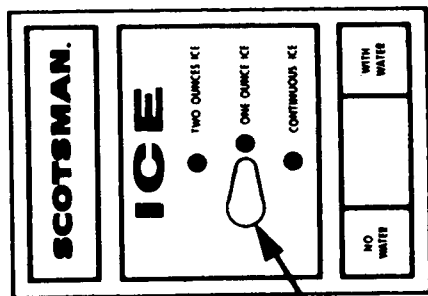

1 oz & 2 oz. ICE SWITCH SETTING INSTRUCTIONS:

1. Set selector switch to 1 oz. or 2 oz. ice.
2. Remove cam switch cover.
3. Turn master switch on by pressing white button down.
4. Loosen two screws slightly.
5. Pull back on screws until dispenser motor runs continuously.
6. Push screws forward slowly until dispenser motor stops and then push 1/32 to 1/16 further.
7. Hold position and tighten screws snugly.

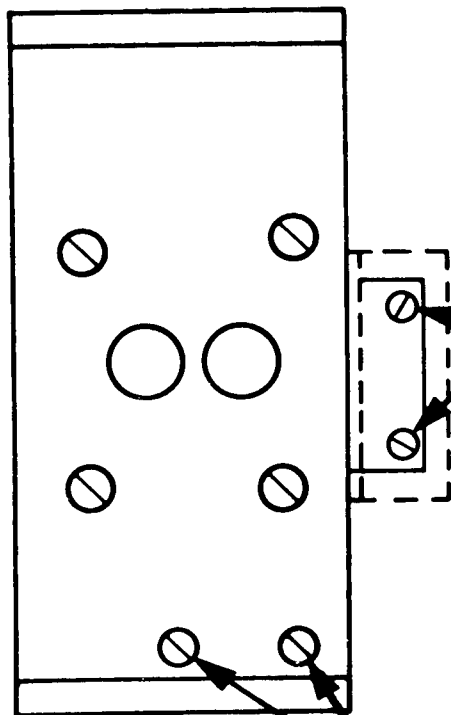

CONTINUOUS ICE SETTING INSTRUCTIONS:

1. Set selector switch to continuous ice.
2. Turn master switch on by pressing white button down.
3. Loosen two screws slightly.
4. Push screws forward slowly until dispenser motor runs continuously.
5. Pull screws back until motor stops.
6. Hold position and tighten screws snugly.

SHUTTER AND BIN ASSEMBLY AND ADJUSTMENT

1. Assemble the shutter in the bin and place the tapered bottom over the shutter. The opening in this bottom (see drawing page 16) is placed over the discharge spout area. Pins in the bottom of the outer pin protrude through slots in the side of this bottom which thereby locks and holds it in place. The rotating dispensing bin is then set over this bottom.
2. Mount the cover on the bin being careful that the slots in the drive shaft are over the pin in the shaft of the dispensing bin. Bolt the cover down lightly with the three winged nuts. (Never Tight).
3. The shutter must be directly over the rubber discharge spout when the dispenser stops. The dispensing bin is timed, by construction, with the shutter, in that the fins of the bin are directly under the freezer spout when the shutter is in proper stopped position. Consequently both sides of the bin will fill with ice.

THE ADJUSTMENT

1. If shutter does not close the ice spout opening when the dispenser motor stops, be sure the cam switches are adjusted as per page 14.
2. To adjust shutter remove the bin cover and turn upside down.
3. Turn the motor until the roller of the continuous ice cam switch (the singularly mounted switch) is down in the slot of the cam. This is illustrated in the sketch of the cam and switches on page 13.
4. In this position the slot of the motor drive shaft should be in line with the plunger of the spout switch.
5. To adjust, loosen the two set screws No. 11 of cam (see section AA - page 18). Hold cam as described in above paragraph 3 and turn motor until drive shaft slot is correctly in line with spout switch plunger.
6. Tighten set screws in cam. (Do not over tighten or the plastic cam may split).
7. Rotate the motor - check the vertical position of the cam. Switch rollers must fall in the correct cam slots as indicated on page 13.
8. Hold master switch down and vend several times. Each time the dispensing motor stops the slot in the end of the drive shaft should line up with the plunger of the spout switch.
9. Place cover on storage bin. Press down on vend switch until slot in drive shaft falls over pin in rotating bin.
10. Turn down thumb screws on cover slightly (never tight).
11. Actuate the dispenser several times. Check the shutter through the rubber discharge spout. It must close discharge spout at the end of each dispense.

STORAGE BIN AND FD3
DISPENSING ASSEMBLY

ITEM NO.	PART NO.	DESCRIPTION
1.	A16098-000	Bin Cover only
2.	A20912-000	Drive Pin - Top
3.	A16005-000	Tie Bolt Bracket
4.	A21485-000	Outer Bin
5.	03-0255-00	Wing Nut
6.	A15965-000	Shutter Assembly
7.	A22479-000	Storage Bin
8.	A16129-000	Bin Bottom

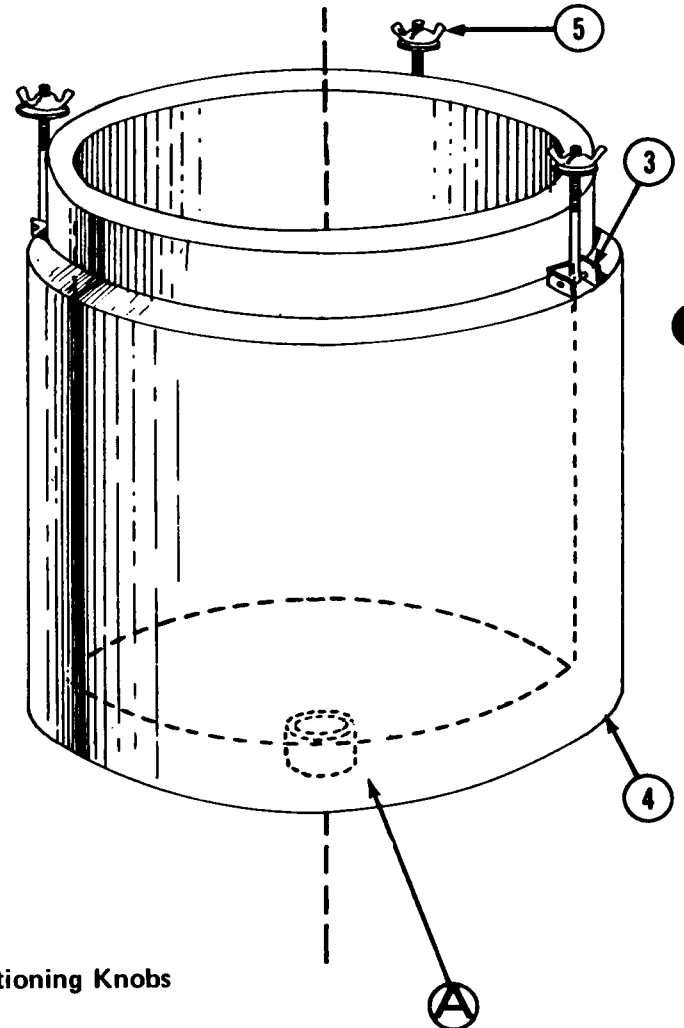
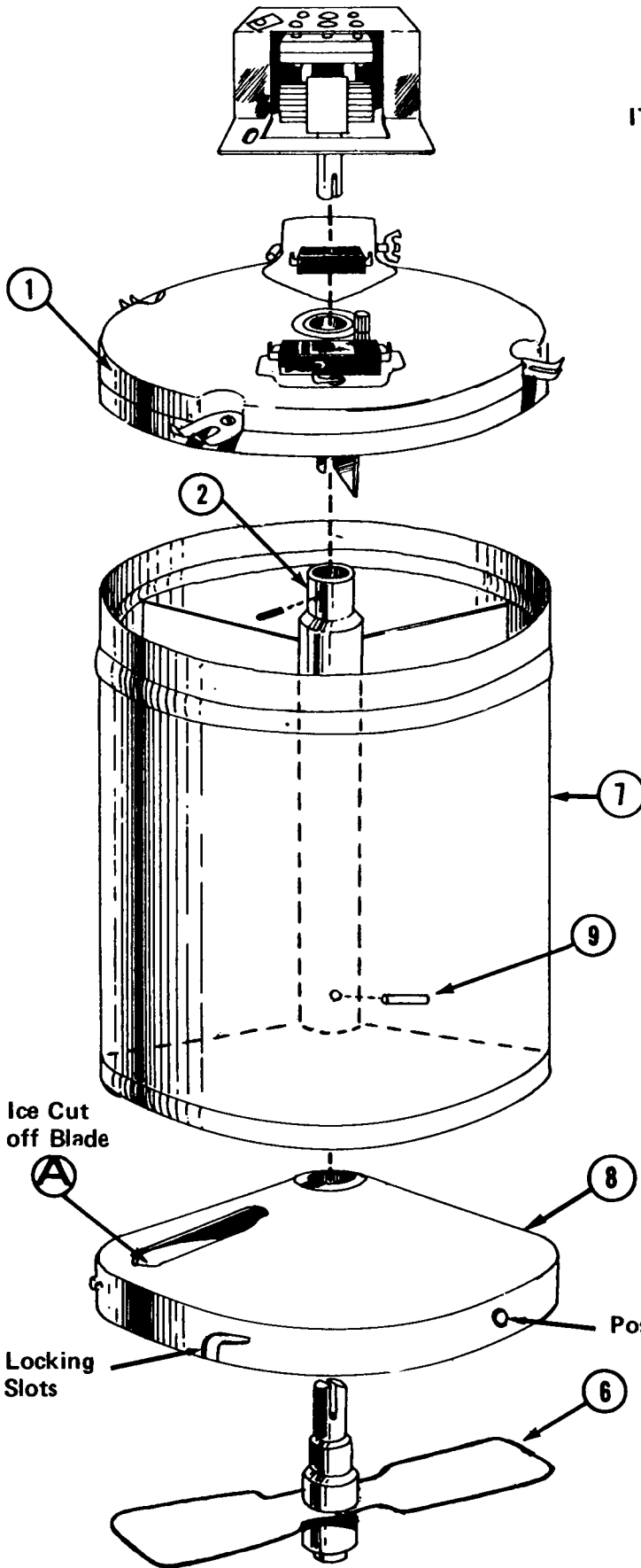

Position Ice Cutoff Blade
Over Spout Opening When
Assembling.

BIN CONTROLS

There are two controls located on the underside of the cover that govern the amount of ice that is in the bin. One control, that over the spout of the freezer, turns the freezer off when the bin is full of ice. This control must be in a position as illustrated in drawing page 18, Section B-B. The second control (see Section C-C page 18) hangs into the bin and holds the freezer off for a period of vends. This flipper slides upon the ice at the first ice vend and opens the switch contacts. It operates as a differential to keep the unit from starting and stopping at each vend and is a secondary means of stopping the unit should the spout switch fail.

Both of these controls can be easily removed for cleaning. The bin differential control has two fasteners securing it to the cover. They are tall round, knurled tubes which are unscrewed like a nut. Removing these two fasteners will drop the differential control from the cover.

The spout of the freezer has an extension that slides over the fixed spout. This removable extension has two small ears on the side. It is necessary when replacing the cover on the bin to slide this extension as far back on the freezer spout as possible. Be sure the small ears of the extension are on the outside of the cover. When the cover has been fitted over the bin and before it is bolted down, this extension should be slid toward the cover until the ears rest against it.

Serious damage could result if the cover is not installed properly. The small flipper over the switch button in the ice spout of this cover must definitely be forward. Check section B-B, page 18 carefully before attempting to install the cover.

To further control the compressor and to avoid the freezing and stoppage of the auger in the freezer a control is incorporated on the gear motor drive for the freezer.

The bin controls do not energize the compressor but only the gear motor. In turn the gear motor operates the compressor.

A speed sensing switch mounted on top of the motor of the gear unit will stop the compressor when the RPM of the motor is less than 900. At 1200 RPM it will start the compressor.

Should the auger begin to freeze the speed of the gear motor is reduced due to excessive load. At 900 RPM it opens the circuit to the compressor and thereby stopping the freezing. As the gear unit, only, continues to run it will clear the auger and when the motor speed reaches 1200 RPM, the compressor is turned on.

Any freeze ups are thereby automatically cleared by the unit.

If the water should be shut off when the unit is running, the inlet water line will freeze shut. The control mentioned above will have no control over such a situation.

STORAGE BIN TOP ASSEMBLY

ITEM NO.	PART NO.	DESCRIPTION
1.	A21215-000	Storage Bin Top Assembly
2.	A18468-000	Motor Mount
3.	12-0876-00	Positioning Switch (Continuous ice)
4.	A16498-000	Switch Cover
5.	A16104-000	Hinge Pin
6.	03-1229-00	Wing Nut
7.	A16499-000	Switch Cover
8.	12-1610-01	Dispenser Drive Motor
9.	02-1576-00	Cam
10.	A21207-000	Drive Shaft
11.	03-0387-00	Set Screws
12.	12-0876-00	Cam Switch (two ounces ice)
13.	12-0876-00	Cam Switch (one ounce ice)
14.	A16101-000	Cover Bushing
15.	12-1018-01	Spout Switch
16.	12-1643-00	Boot & Bushing
17.	A16010-000	Ice Control Lever
18.	A16495-000	Differential Bracket Nut
19.	12-1018-01	Differential Switch
20.	A19269-000	Differential Paddle

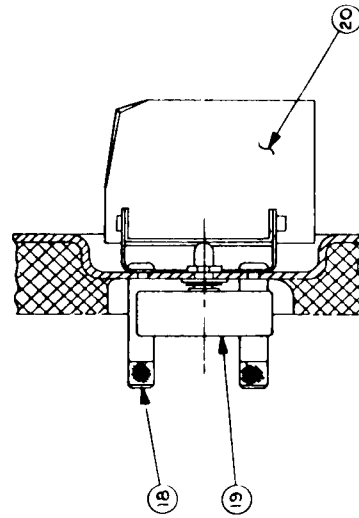
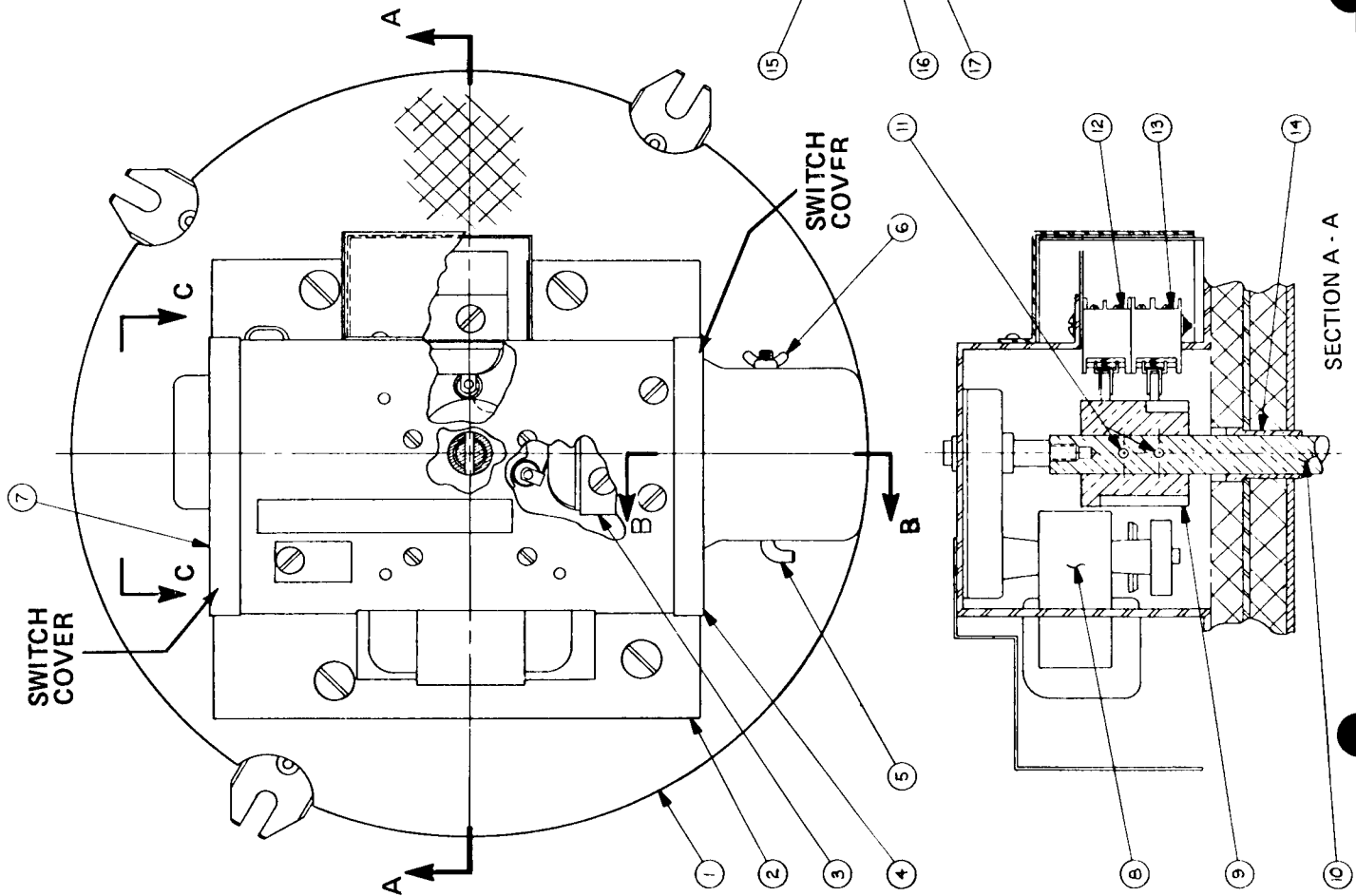

SECTION C - C

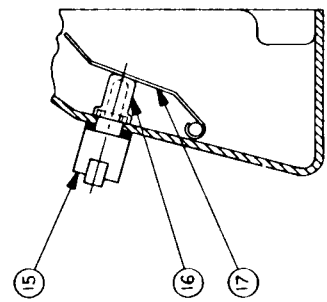

SECTION B - B

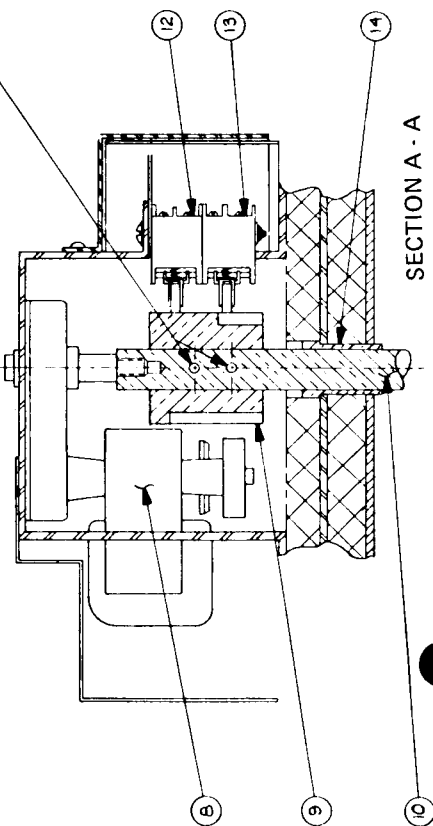

SECTION A - A

FD3 DISPENSER CONTROL SYSTEM

The control system, for the dispenser only, consist of six switches. The terminology and function of these switches are as follows:

DISPENSING SWITCH:

1. Located in the sink area on firewall back of the sink. It is accessible by removing the right side panel.
2. When depressed, usually by a water glass, it actuates the dispensing mechanism.
3. It is a double pole, double throw leaf type snap switch.

SELECTOR SWITCH:

1. Located on the frame back of the front panel. It is accessible by removing the front panel.
2. By its setting, it determines if one of two ounces of ice will be dispensed. In the continuous setting the dispenser is operated as long as the dispensing switch is held "IN".
3. This is a three position, 30 degree throw rotary switch.

CONTINUOUS CAM SWITCH:

1. This is the single top switch riding on the upper edge of the cam.
2. This is actually a locating switch that will always stop the dispensing mechanism when the shutter is covering the dispensing opening. When the selector switch is set for "continuous" ice, the dispenser operates as long as the dispensing switch is held in. When this dispensing switch is released, the continuous cam switch will hold the circuit on until the shutter is over the discharge spout or opening.
3. This switch is a single pole double throw roller type switch. Only two terminals, the common and normally open, are used.

MAXIMUM 1 or 2 oz. CAM SWITCH:

1. This is the top switch of the two cam switches that are mounted together. It rides on the center of the cam.
2. When the selector switch is set at 2 oz. this will control the dispensing drum to one full turn.
3. It is a single pole double throw roller type micro switch.

MINIMUM or 1 oz. CAM SWITCH:

1. This is the lower switch of the two cam switches that are mounted together. It rides on the lower edge of the cam.
2. When the selector switch is set at one ounce it will control the dispensing drum to 1/2 turn.
3. This switch is a single pole double throw roller type micro switch.

WATER SWITCH:

1. Located on the front panel.
2. When in an "ON" position, it energizes a water solenoid to dispense water with ice.
3. This is a rocker type single pole single throw switch.

Besides the two flaker control switches covered in the information on this unit, there is a master switch.

This switch is located on the top frame and is a plunger type single pole single throw switch. It is held in an "ON" position by the cabinet top. When top is removed the switch is in an open position.

WIRING DIAGRAM
FD3
115/60/1

A24968-001

CONTROLS SHOWN IN THE ICE MAKING MODE
WITH ALL DISPENSING SYSTEMS IN OPERATION

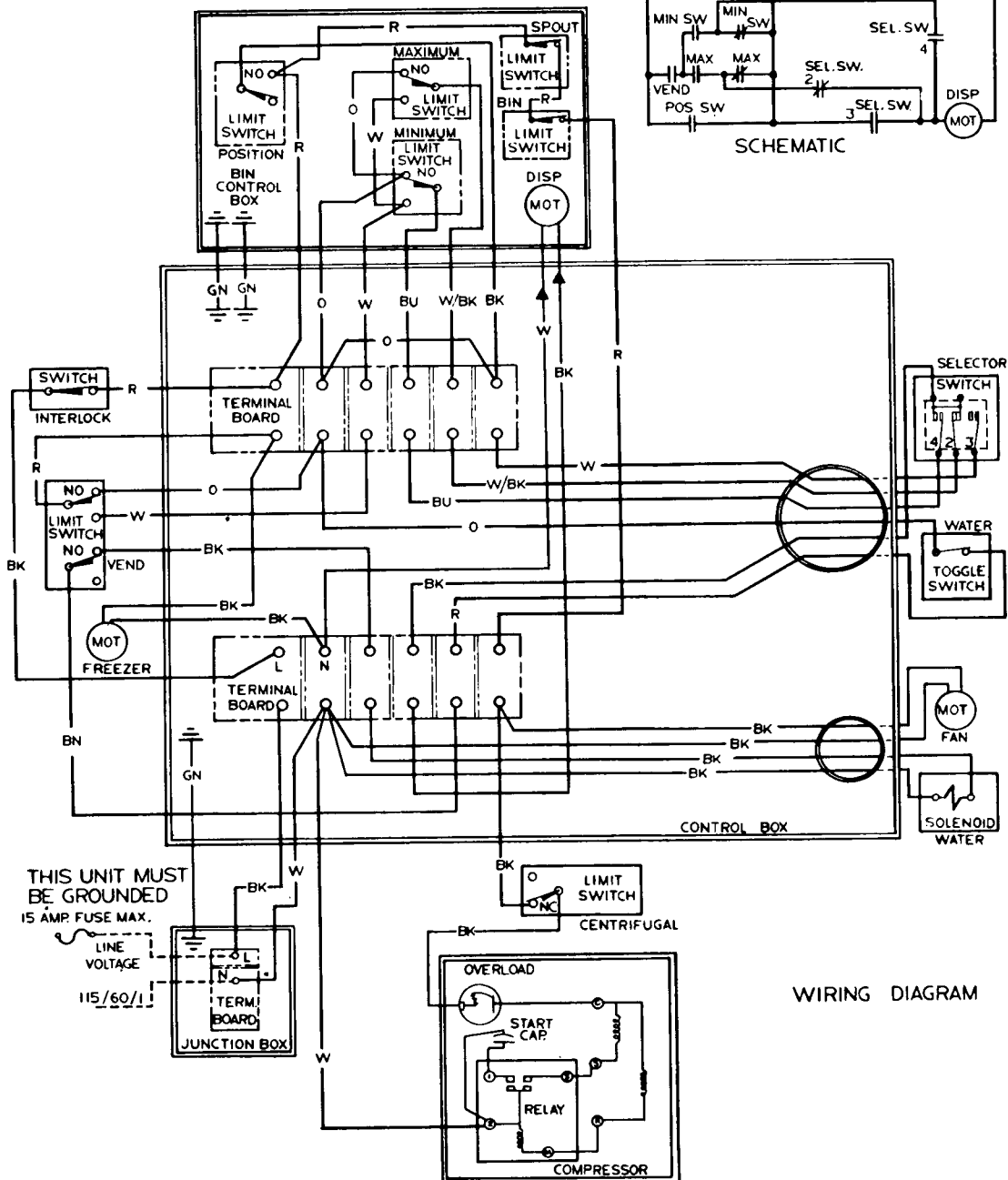
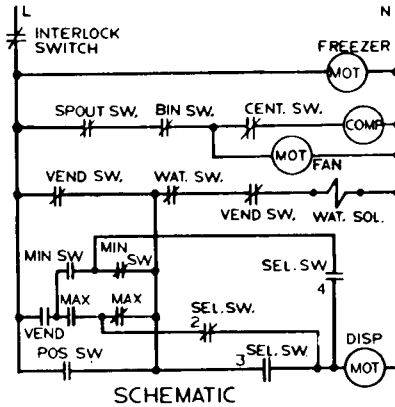

THIS UNIT MUST
BE GROUNDED
15 AMP FUSE MAX.

LINE
VOLTAGE
115/60/1

WIRING DIAGRAM

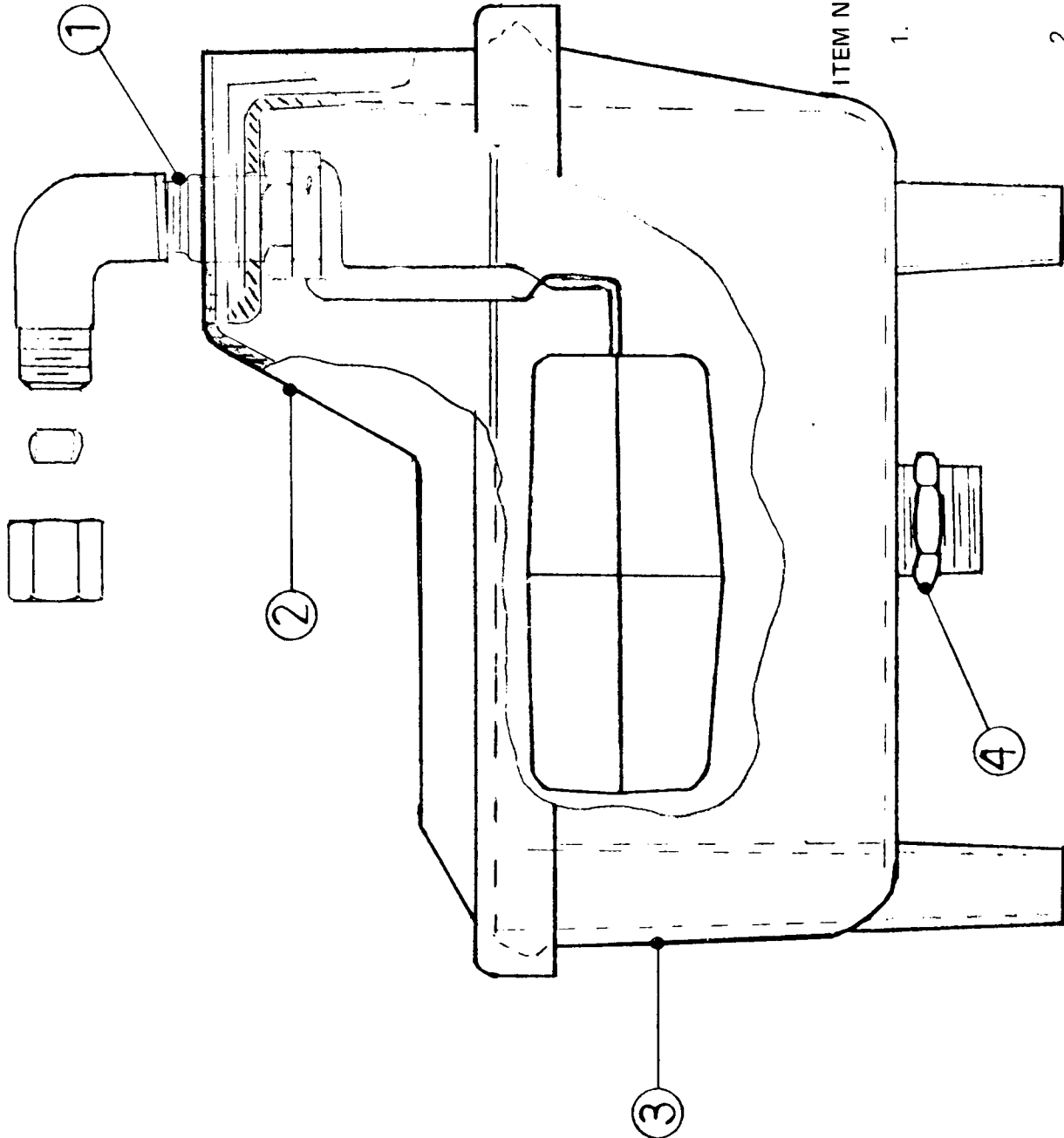

RESERVOIR ASSY. A22348-000

ITEM NO.	PART NO.	DESCRIPTION
1.	02-1793-02	Valve Assembly consisting of: Inlet Ell Straight Compression nut Compression Sleeve Valve Assembly with Float
2.	02-1793-03	Reservoir Cover
3.	02-1793-04	Reservoir Body
4.	02-1793-05	Reservoir mounting nut 3/8-18

CABINET PANELS – CHASSIS
FD3 MODELS

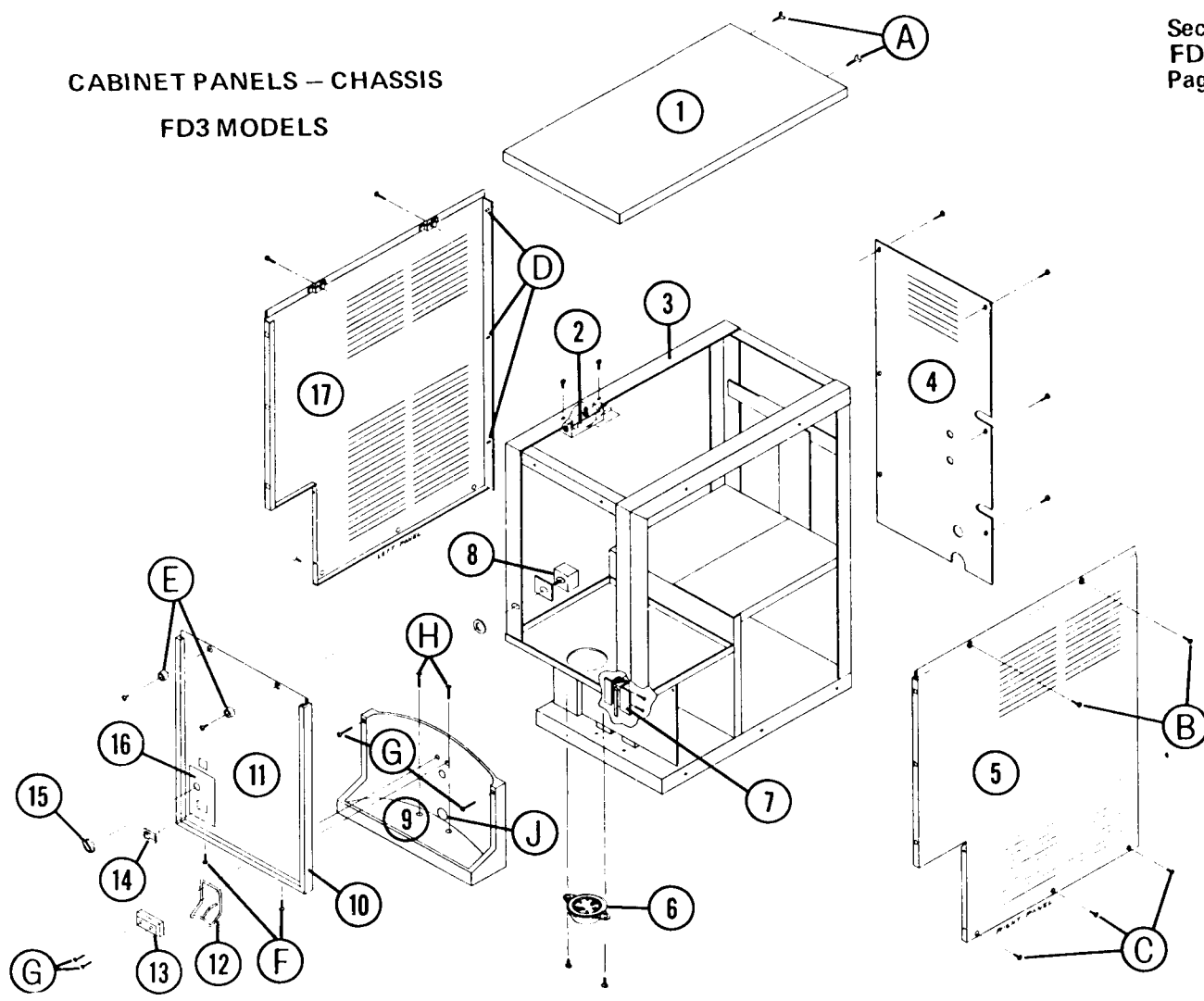

REMOVING PANELS & SINK

ITEM NO.	PART NO.	DESCRIPTION
1.	A19104-004	Cabinet Top—Painted
	A19104-001	Cabinet Top—Stainless Steel
2.	12-1570-00	Master (interlock) Switch
3.		Frame
4.	A21405-002	Back Panel—Painted
	A21405-001	Back Panel—Stainless Steel
5.	A21416-002	Right Side Panel—Painted
	A21416-001	Right Side Panel—Stainless Steel
6.	02-1804-00	Spout Extension
7.	12-1641-00	Vend Switch
8.	12-1540-00	Selector Switch
9.	02-1826-00	Sink
10.	15-0507-00	Moulding Trim
11.	A21425-002	Cabinet Front—Painted
	A21425-001	Cabinet Front—Stainless Steel
12.	A21554-000	Actuator Arm
13.	02-1833-00	Actuator Arm Adapter
14.	12-1877-00	Water Switch
15.	12-15566-00	Switch Knob
16.	15-0461-00	Decal
17.	A21415-002	Left Side Panel—Painted
	A21415-001	Left Side Panel—Stainless Steel
A.	03-1279-00	Wing Screw
B.	03-1418-05	Screw

- To remove either side panel or front, first remove the two wing bolts in the back of cover No. 1, Item (A). Lift the back of the cover upward and push forward to release.
- Either side panel can be taken off by removing two screws across the top (B) and three across the bottom of the panel. (C) These are the only screws that hold the panel. Pull the panel from in back of sink, then slide backward about 1/2 inch. There are no screws in the back of the panel, only pins that slide into holes in the frame. (D) The front edge of the panel merely fits under the aluminum trim.
- The front panel is removed by unscrewing the two rubber bumpers at the top of the panel (E) and two screws under the sink top area. (F) The water switch (14) will snap out and the quick connects can be removed from the switch. The selector knob (15) just pulls off.
- The sink (9) can be removed by removing four screws (G) on the front side of the switch and two screws in the bottom of the sink. (H) These screws are sealed to eliminate water leaks. The drain tube connection (J) is fastened to the sink rear by a hose clamp. To remove the clamp, it is necessary to remove the right side panel.
- Remove top and left side panel to clean air cooled condenser.

CHASSIS ASSEMBLY
Right Side

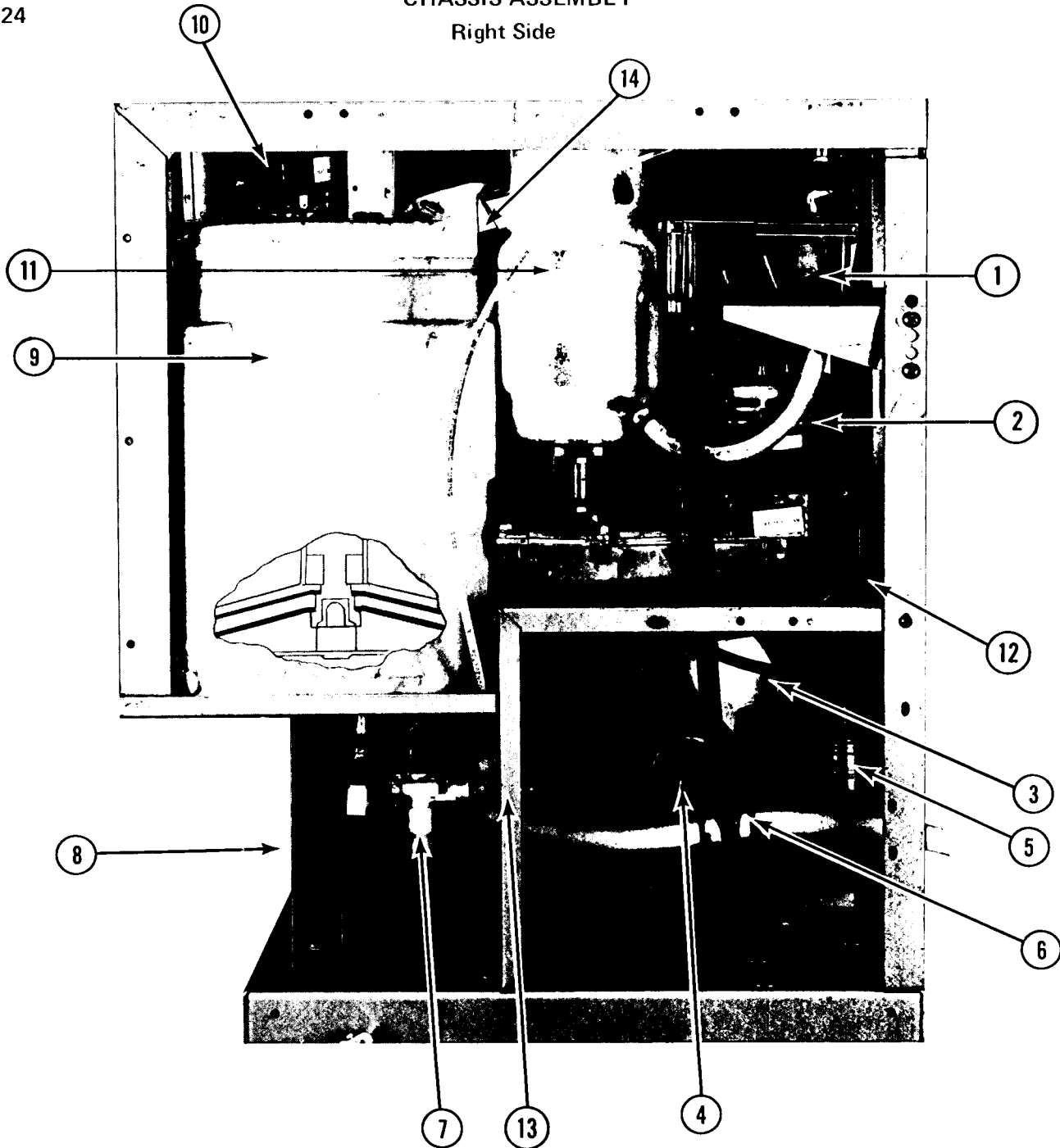

ITEM NO.	PART NO.	DESCRIPTION	ITEM NO.	PART NO.	DESCRIPTION
1.	A22348-000	Reservoir Assembly	8.	12-1641-00	Vend Switch
2.	A17905-021	Gear Motor Assembly	9.	A21485-000	Outer Bin Assembly
3.	18-0137-00	Fan Blade	10.	12-1610-01	Dispensing Drive Motor Use with A21207-000 Drive Shaft
4.	12-1575-01	Fan Motor	11.	A21435-020	Freezer Assembly
5.	02-1752-01	Drier	12.		Electrical Hook Up Box
6.	02-1338-00	Hose Clamps	13.		Water Supply Inlet
7.	A21382-000	Inlet Water Solenoid	14.	A16151-000	Spout Extension

CHASSIS ASSEMBLY

Left Side

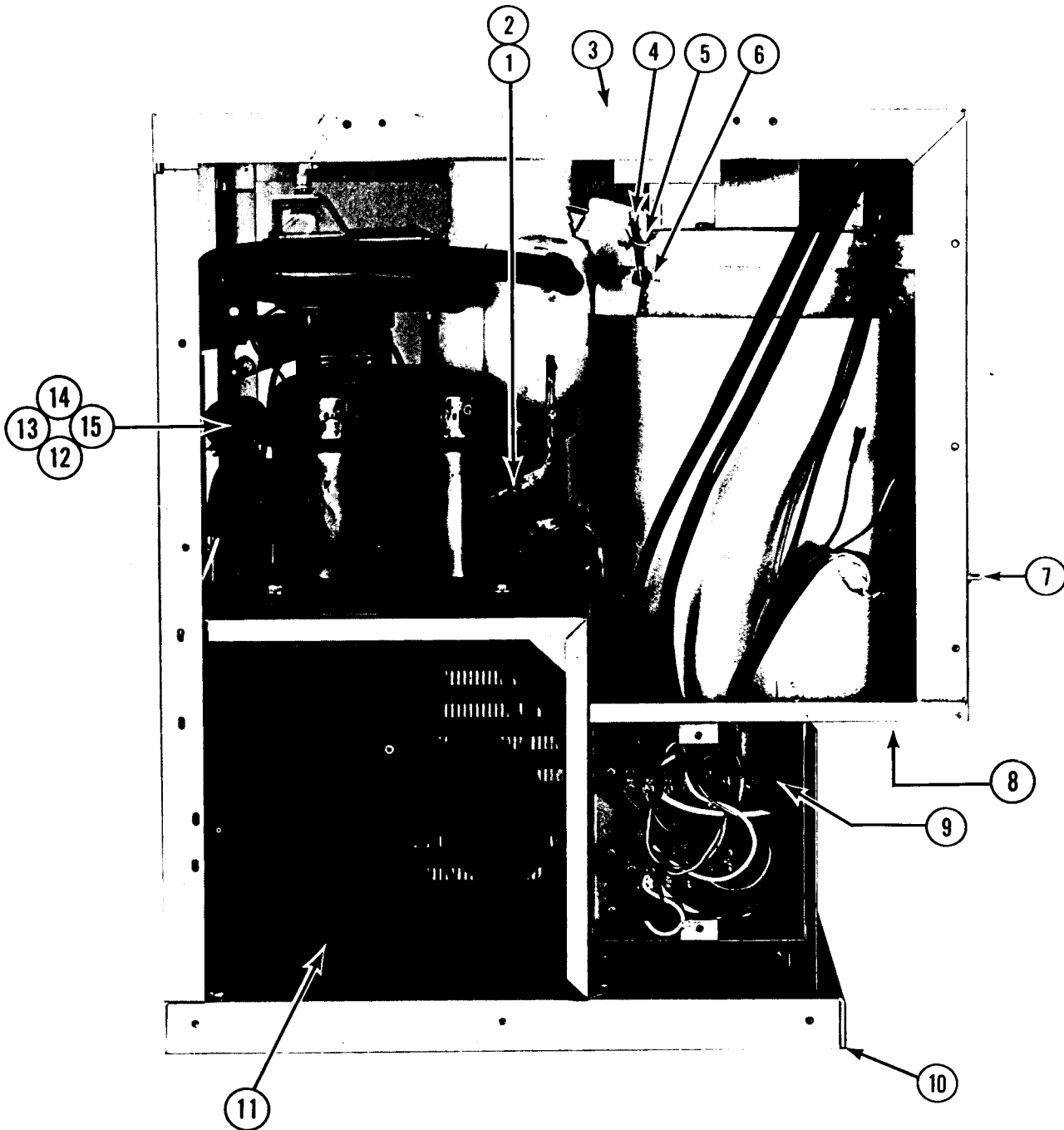

ITEM NO.	PART NO.	DESCRIPTION	ITEM NO.	PART NO.	DESCRIPTION
1.	16-0563-00	Service Valve Cap	9.	A21432-001	Wiring Panel Box
2.	16-0560-00	Service Valve Core	10.	13-0566-00	Base Gasket
3.	12-1570-00	Safety Switch	11.	A18374-000	Condenser
4.	A16004-000	Tie Bolts	12.	18-0161-01	Motor Compressor
5.	03-0255-00	Wing Nuts	13.	18-0161-02	Compressor Overload
6.	03-1069-00	Cotter Pins	14.	18-0161-03	Compressor Relay
7.	12-1540-00	Switch	15.	18-0161-05	Starting Capacitor (189-220)
8.	02-1804-00	Plastic Spout Extension			

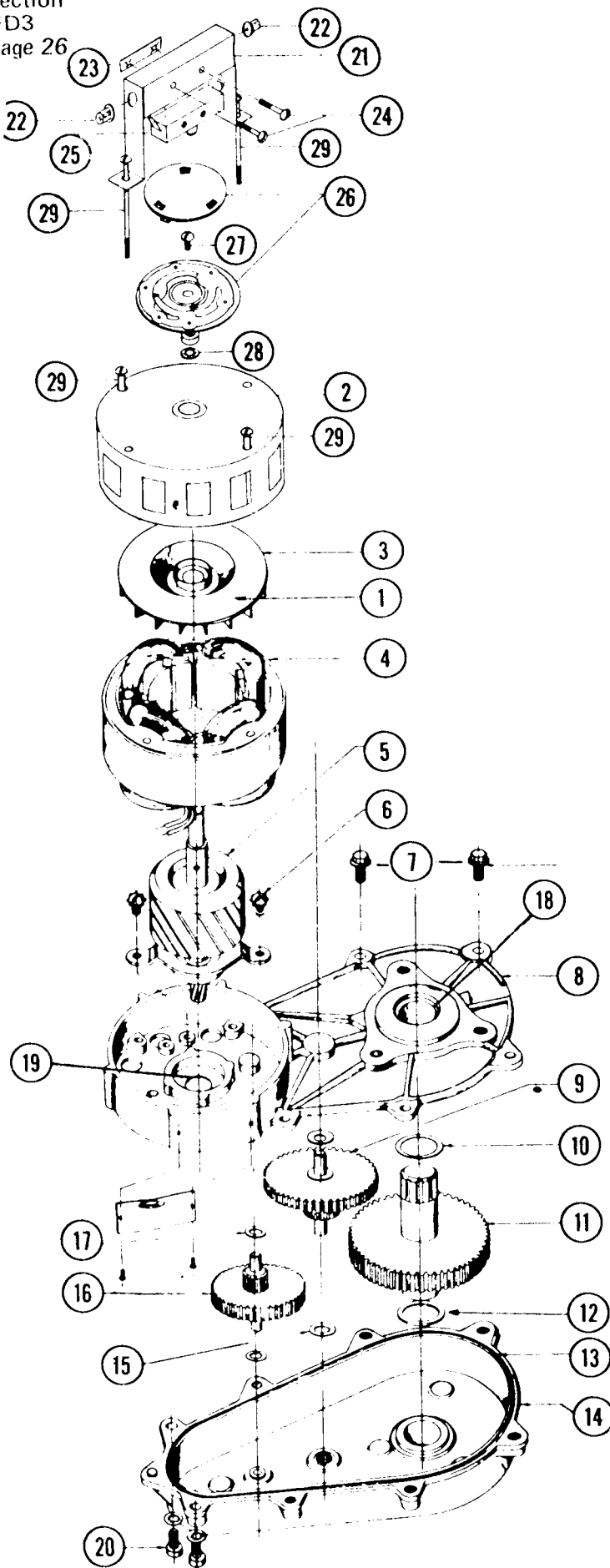

FD3 GEAR MOTOR ASSY.

ITEM NO.	PART NO.	DESCRIPTION
1.	03-1246-00	Fan Set Screw
2.	A17047-000	Motor Housing
3.	A16915-000	Cooling Fan
4.	12-1343-01	Stator Assy.
5.	A19884-01	Rotor Assy.
6.	03-1245-00	Screws
7.	03-1251-00	Flange Screws
8.	A24184-001	Gear Case Covers (Includes Item 14)
9.	02-1510-00	Gear & Pinion
10.	03-1408-05	Washer
11.	02-1513-00	Gear & Output Shaft
12.	03-1408-04	Washer
13.	02-1505-00	"O" Ring
14.	A24184-001	Gear Case Assy. (Includes Item 8)
15.	03-1408-06	Washer
16.	02-1511-00	1st Gear & Pinion
17.	03-1408-07	Washer
18.	02-1503-00	Grease Seal
19.	02-1504-00	Grease Seal
20.	03-1252-00	Screw
21.	08-0579-00	Switch Bracket
22.	12-1213-03	Snap Bushings
23.	03-0886	Twin Speed Nut
24.	03-1403-10	Screws
25.	12-1644-00	Switch
26.	A19898-000	Synchro Snap Assy.
27.	03-1248-01	Screw
28.	03-1407-06	Washer
29.	03-1403-42	Motor Bolts
30.	A16914-00	Bearing

A-17905-21 Gear Motor Assy. Complete

Output Shaft turns at 7 RPM.

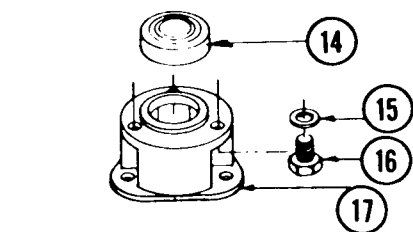
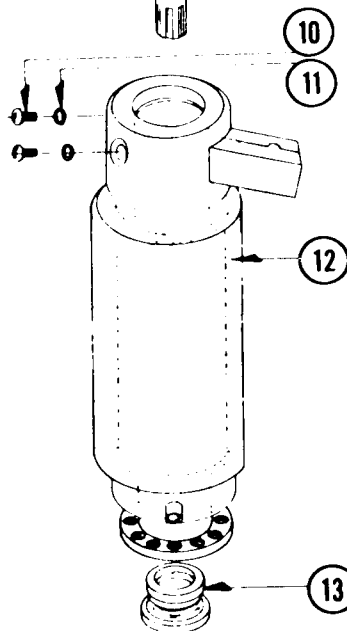
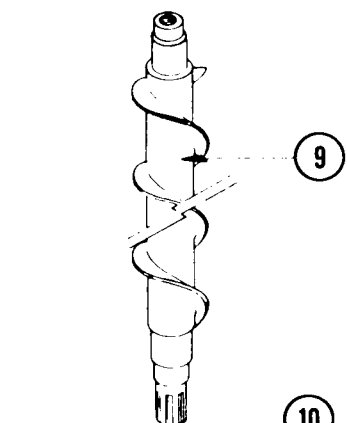
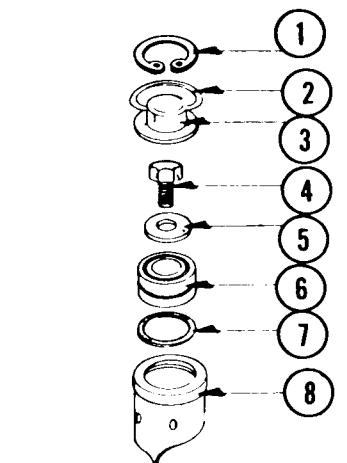

FD3 FREEZER ASSY.

ITEM NO.	PART NO.	DESCRIPTION
1.	03-0553-00	Retainer Ring
2.	A08162-000	Cap Hook
3.	A07701-000	Cap
4.	03-0758-00	Screw
5.	A07699-000	Washer
6.	02-0547-00	Top Bearing
7.	13-0617-16	"O" Ring
8.	A09413-000	Breaker
9.	02-1313-00	Auger
10.	03-1403-46	Screw
11.	03-1417-07	Washer
12.	A21434-020	Evaporator Shell Includes Suction Line, Etc.
13.	A18945-000	Water Seal
14.	02-0417-00	Bearing, Lower
15.	03-1408-03	Washer (3 reqd)
16.	03-1405-14	Cap Screw
17.	15-0575-01	Coupling Gasket
	03-1505-00	Gasket
	A23073-000	Adapter-Plastic
18.	15-0575-01	Spline Drive Coupling
19.	13-0709-01	Shaft Drip Shield - rubber
	A21435-000	Freezer Complete With Suction Line

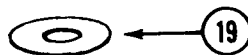
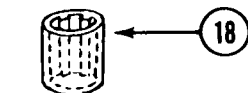

SERVICE ANALYSIS
ICE MAKER SECTION FD3

SYMPTOM	POSSIBLE CAUSE	CORRECTION
Water Leaks	Defective water seal. Gravity feed line leaking. Water level in reservoir too high.	Replace. Check hose clamps. Adjust to 1/4 inch below overflow pipe.
Excessive noise or chattering.	Mineral or scale deposit on auger and inner freezing chamber walls. Low suction pressure. Intermittent water supply. Water level in reservoir too low. Gear reducer loose on frame. Motor compressor not solid on rubber mounts.	Remove and manually polish auger, polish inner chamber walls of freezer barrel. For lighter concentration use Scotsman Ice Machine Cleaner periodically. Add gas to raise suction pressure. Check and clean water strainer. Check gravity feed line for air lock. Remove air lock. Adjust to 1/4 inch below overflow pipe. Tighten bolts. Repair or replace rubber mounts.
Gearmotor noise.	Low on oil.	Remove case cover to check for proper oil level. Top of gears should be covered. Use Sun Oil Co. — Prestige 50 A.E.P.
Unit will not run.	Blown fuse. Loose electrical connection. Inoperative master switch.	Replace fuse and check for cause of blown fuse. Check wiring. Replace switch.
Compressor cycles intermittently.	Low voltage. Dirty condenser. Air circulation blocked. Inoperative condenser motor. Non-condensable gases in system.	Check for overloading. Clean. Move unit to correct. Replace. Purge off.

SERVICE ANALYSIS
ICE MAKER SECTION FD3

SYMPTOM	POSSIBLE CAUSE	CORRECTION
<p>Making wet ice.</p>	<p>Surrounding air temperature. Under or over-charge of refrigerant. High water level in water reservoir. Faulty compressor.</p>	<p>Correct or move unit. Recharge with the proper amount. Lower to 1/4 inch below overflow pipe. Replace or repair.</p>
<p>Low ice production.</p>	<p>Loss of refrigerant, under or over-charge of refrigerant. Dirty or plugged condenser. Low water level in water reservoir. Partial restriction in capillary tube or drier. Inlet water strainer, partially plugged. Corroded or stained worm shaft due to water condition.</p>	<p>Check and recharge with proper amount of refrigerant. Clean condenser. Adjust to 1/4 inch below overflow pipe. Moisture in system. Overcharge of oil in system. Remove charge and drier. Replace and recharge system. Remove screen and clean. Remove worm shaft and clean.</p>
<p>Machine runs but makes no ice.</p>	<p>Loss or under-charge of refrigerant. Water not entering freezing chamber. Moisture in system. Water seal leaking. Water turned off while unit was operating.</p>	<p>Check for leaks and recharge. Plugged strainer or supply line. Check and clean. Air lock in gravity feed line. Check and remove air lock. Check and remove charge and drier. Replace and recharge. Replace seal. Inlet water line froze shut. Unit must be turned off and defrosted.</p>
<p>Will not dispense.</p>	<p>Power off. Motor overload open. Cam switches improperly set. Master switch open. Spout jammed with ice. Unit not level or holding glasses against spout. Wires off dispensing switch.</p>	<p>Check fuses and plug. See correction under motor overload. Adjust per manual. Cabinet cover must be on tight to keep switch on. Remove ice and clear ice under removable bottom. Check reservoir possibly too high. Check switch terminals.</p>

SERVICE ANALYSIS
DISPENSING MECHANISM

SYMPTOM	POSSIBLE CAUSE	CORRECTION
<p>Motor hot—Overload Open.</p>	<p>Ice under removeable bottom. Wing nuts on cover turned down too tight. Shutter or rotating bin does not turn free. Ice too hard.</p>	<p>Remove ice. Keep wing nuts only slightly snug — never tight. Check and repair any drag. Raise freezer water level and check refrigerant charge.</p>
<p>Dispenser does not stop.</p>	<p>Brake on drive motor not working properly. Cam switches out of adjustment.</p>	<p>Brake must be free and stop the motor before 5 revolutions after the dispensing switch is released. Check switches and set per manual.</p>
<p>Water will not dispense.</p>	<p>Solenoid defective. Lines closed up.</p>	<p>Replace. Clean.</p>
<p>Water runs too slow.</p>	<p>Water line too small.</p>	<p>Increase size.</p>

MAINTENANCE INSTRUCTIONS – FLAKER SECTION

THE FOLLOWING MAINTENANCE SHOULD BE SCHEDULED THREE TIMES PER YEAR.

1. Check and clean water strainers and float valve. Depress float valve to insure full stream of water.
2. Check water level and machine level. Keep water level below overflow, but as high as possible and still not run out of spout opening with machine off. Water should come out of spout with ice at all times. Adjust as required.
3. Clean reservoir and interior of freezer assembly using SCOTSMAN Ice Machine Cleaner. See cleaning instruction on next page.

A. If machine has been cleaned regularly and no problem such as dry ice or chatter are noticed, clean by making ice from solution of 4 oz. of cleaner to 2 quarts of water.

B. If heavy mineral deposits on auger and walls, or sediment at inlet to freezer are encountered, clean by pouring strong solution 1/2 acid – 1/2 water into reservoir and operate drive motor only for agitation. Allow 1/2 hour or longer as required. Drain by disconnecting tygon at water inlet to freezer.

NOTE: Cleaning requirements vary according to local water conditions. Visual inspection of the auger before and after cleaning will indicate best procedure to be followed in local area.

4. Check top bearing of freezing tube. Remove retainer ring around edge of stamped brass cap, pull cap off. If moisture is around bearing, wipe up and remove grease. Add new grease. Use Beacon No. 325 or equal.
5. Clean air cooled condenser. Always shut off machine when cleaning.
6. Oil condenser fan motor when possible.
7. Check for refrigerant leaks and proper frost line. Should frost out of accumulator at least one-half way to compressor, and in some areas, back to service valve.
8. Check for water leaks. Tighten drain line connections. Run water down drain line to make sure it is open.
9. Check quality of ice. Ice should be wet when formed, but will cure rapidly to normal hardness in the bin.

CLEANING INSTRUCTIONS FOR FD3

1. Set selector switch to continuous ice and vend until bin is empty.
2. Remove top cabinet cover.
3. Remove storage bin cover and spout extension.
4. Remove both ice control flippers from storage bin cover. Note positions of these parts, if parts re-assembled incorrectly damage to the machine may result.
5. Remove inner bin and bin bottom.
6. Position shutter over rubber ice spout and replace bin cover.
7. Turn OFF water supply or block float. Drain reservoir by disconnecting tube between reservoir and freezer. After draining, reconnect tubing.
8. Block main switch ON and pour cleaning solution into reservoir. (Use 4 oz. of Scotsman cleaner and 1 qt. of hot water). Do not fill above overflow tube. Do not allow unit to operate with less than 1" of solution in reservoir.
9. While waiting for Step No. 8 and/or No. 11 to complete, remove drain grate and ice vend lever from sink. Wash and sanitize these parts and parts removed from storage bin in accordance with the local health department regulations. (Step No. 8 may complete before Step No. 9).
10. Remove block from main switch. Wash and rinse reservoir, turn water on or remove float block.
11. Block main switch ON. Let unit run for at least 15 minutes to flush out any cleaning fluid. Check ice for acid taste – run until ice tastes sweet.
12. Remove block from main switch and remove bin cover. Add hot water to ice in bin, using this melt water thoroughly wash and rinse the underside of the storage bin top, shutter, rubber ice spout and all surfaces within the storage bin.
13. Using solution from Step No. 9, thoroughly wash and rinse sink.
14. Re-assemble storage bin and sink parts.
15. Replace cabinet cover. Unit is ready for normal operation.

ACCESSORY ITEM

WALL MOUNT KIT
PART NO. KWB1

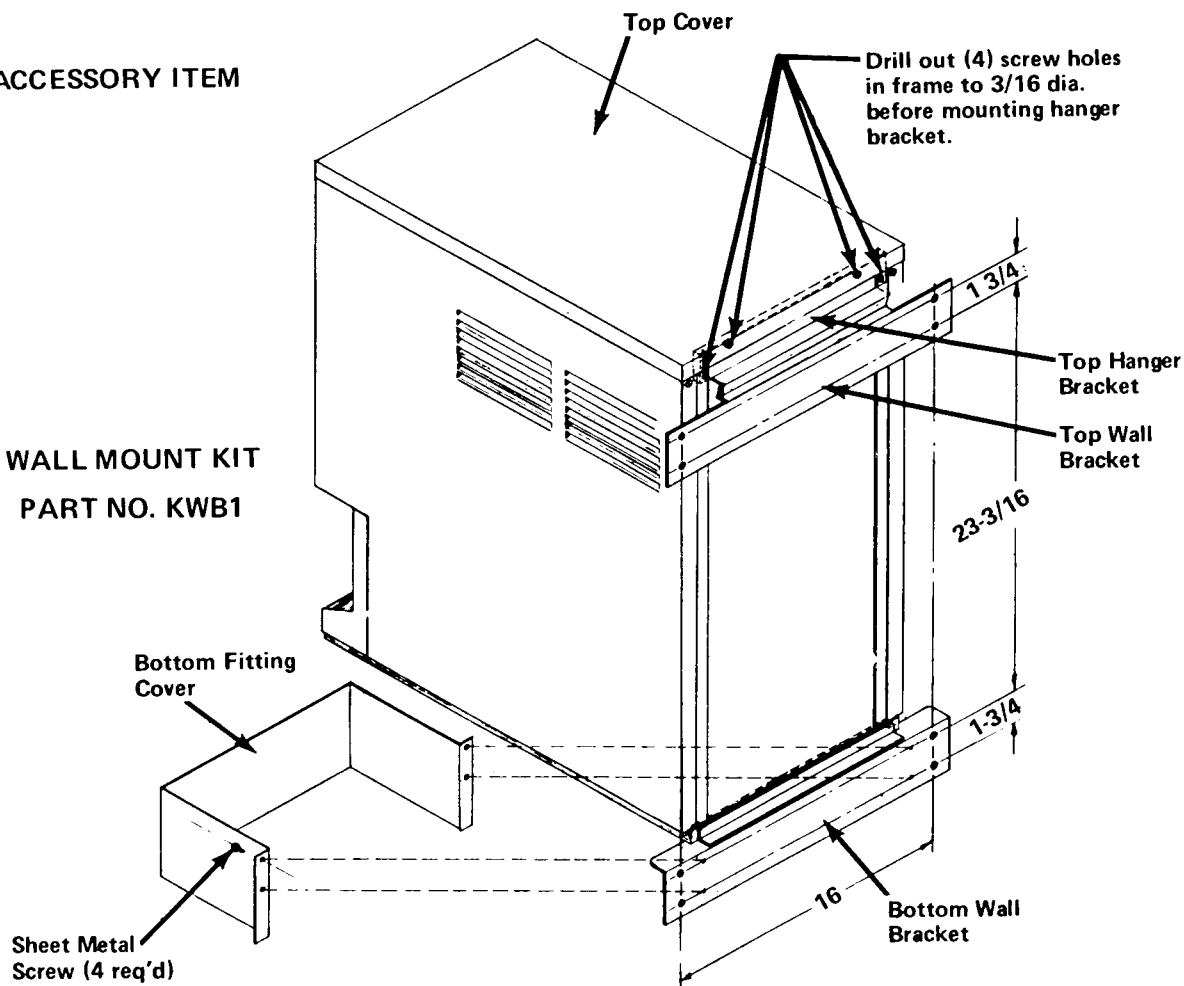

THE KIT

1. Top Case Hanger Bracket
Attach to inside of frame of the dispenser
2. Top Wall Bracket
Mounts to wall and engages top case hanger bracket to support dispenser.
3. Bottom Wall Bracket
Mounts to wall and supports bottom of dispenser.
4. Bottom Fittings Cover
Fastened to bottom wall bracket to conceal electrical and plumbing fittings from view.

TOP HANGER BRACKET:

1. Remove back cover and save four screws for mounting bracket.
2. Remove top cover.
3. Drill out four holes of weld nuts in back of frame with 3/16 dia. drill as indicated in illustration.
4. Place bracket inside of frame and fasten solidly with four screws, saved from Step 1, through drilled out holes.

TOP WALL BRACKET:

1. Position bracket in desired location.
2. Secure to wall with fasteners of any suitable type for that particular wall through the four holes in bracket. These fasteners or lag screws are not furnished. (Be sure to secure bracket rigidly to wall.)

BOTTOM WALL BRACKET:

1. Hang the dispenser on top wall bracket.
2. Position bottom bracket so that molding on dispenser base bottoms in channel of the bracket.
3. Secure bracket to wall through the four large holes with suitable fasteners. (Fasteners not furnished.)

BOTTOM FITTINGS COVER:

1. Connect water inlet, bin drain and sink drain of dispenser through bottom of case. Also run electrical cable in from bottom.
2. Secure fitting cover to bottom wall bracket with the four sheet metal screws provided in this kit.

GENERAL INFORMATION

1. The dispenser is provided with an interlock device.
2. The interlock must be closed before the dispenser will function.
3. The interlock is closed by the top cover of the dispenser. When the cover is tightly in place.
4. To place the cover in proper position, it may be necessary to bend out the back lip of the cover at the screw holes with pliers. Caution! There must be enough friction between the screw heads, (which secure the hanger bracket and the top cover) to hold the cover tightly down on the case and interlock.

SINK EXTENSION KITS
KDE1 – Painted
KDE1-SS – Stainless Steel

KIT:

A19720-000	Sink and Drain Assembly (4) 3-1403-29 Screws
02-1828-00	Splash Plate (6) 3-1403-7 Screws
02-1701-00	Drain Grill (6) 3-1406-1 Nuts
A21538-000	Base (2) 3-1403-6 Screws
A21538-001	Base—Stainless Steel

FEATURES:

By the use of the splash plate, only, and the wall bracket A19090 (another accessory), the FD3 model can be mounted on a wall over an existing sink.

As a counter-top model, the dispenser is mounted on the six-inch base, A21538. The splash plate, sink and grill replace the conventional sink on the models.

INSTALLATION:

1. Remove conventional sink from cabinet.
2. Remove glass actuator arm and holder from sink.
3. Remove drain tube from original sink.
4. Install drain tube to replacement sink.
5. Remove rubber seal from base of the dispenser.
6. Mount the dispenser on base, A21538. The flange of the dispenser base is to fit in slots provided in the base extension. Secure with the 3 screws on each side of base.
7. Mount sink in place and secure with two machine screws.
8. Install splash plate to cabinet with four machine screws, furnished. The splash plate fits over top of sink.
9. Install glass actuator arm and holder to splash plate. The plunger on the arm must operate freely through hole in splash plate.
10. Install grate.

A conversion for the FD3 dispenser to increase the distance between the discharge spout and the sink to twelve inches and to provide a faster sink drainage.

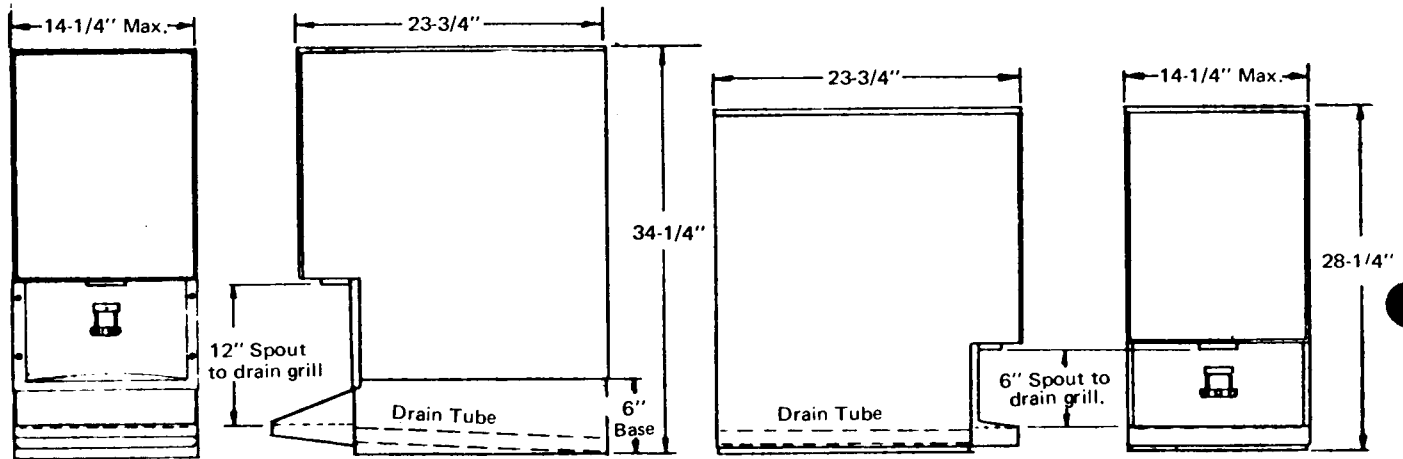
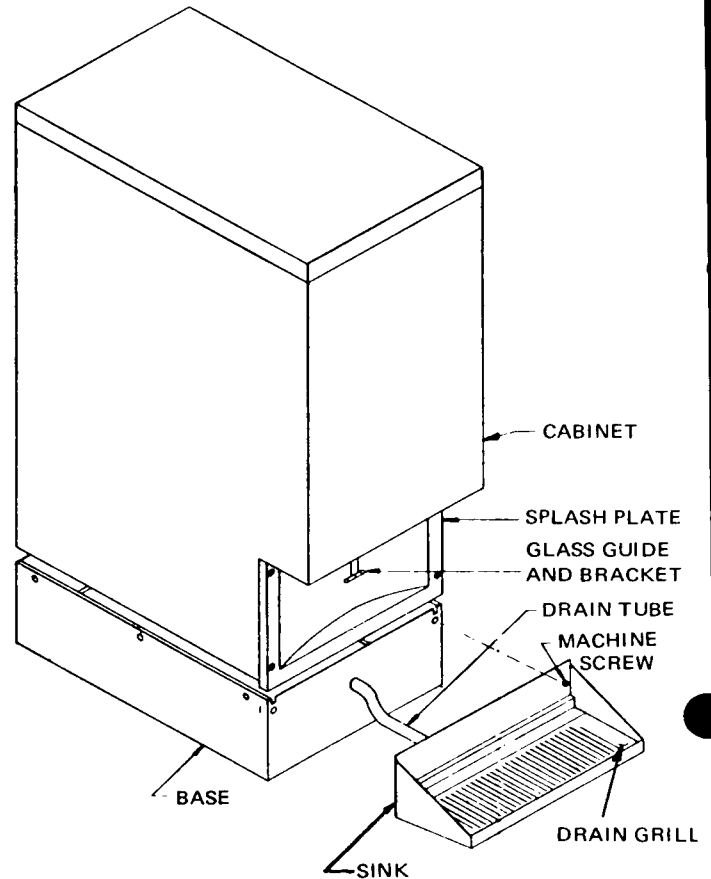

UNIT WITH SINK EXTENSION KIT

UNIT WITHOUT KIT