

TABLE OF CONTENTS

	Table of Contents	i
	List of Illustrations	ii
	Specifications.....	iv
SECTION I -	GENERAL INFORMATION & INSTALLATION	1-1
I.	Introduction	1-1
II.	Unpacking and Inspection	1-1
III.	Location and Leveling	1-2
IV.	Electrical Connections	1-4
V.	Water Supply and Drain Connections	1-4
VI.	Installation - Optional	1-4
VII.	Final Check List.....	1-4
SECTION II -	OPERATING INSTRUCTIONS	2-1
I.	Start Up.....	2-1
SECTION III -	PRINCIPLES OF OPERATION - How It Works	3-1
I.	Freezing Cycle	3-1
II.	Harvest Cycle.....	3-2
III.	Component Description.....	3-2
SECTION IV -	ADJUSTMENT & REMOVAL & REPLACEMENT	4-1
I.	Adjustment of the Bin Thermostat Control	4-1
II.	Adjustment of the Cube Size Control	4-1
III.	Adjustment of the Timer & Switch Assembly.....	4-2
IV.	Adjustment of the Water Regulator - W/C	4-2
V.	Removal & Replacement of the Agitator Motor Assembly	4-3
VI.	Removal & Replacement of the Bin Thermostat Control	4-3
VII.	Removal & Replacement of the Compressor.....	4-4
VIII.	Removal & Replacement of the Condenser - Air-Cooled	4-4
IX.	Removal & Replacement of the Condenser - Water-Cooled	4-4
X.	Removal & Replacement of the Cube Size Control	4-5
XI.	Removal & Replacement of the Curtain Assembly	4-5
XII.	Removal and Replacement of the Drier	4-5
XIII.	Removal and Replacement of the Fan Motor Assembly - A/C	4-6
XIV.	Removal and Replacement of the Freezing Chamber	4-6
XV.	Removal & Replacement of the Spray Bar and Water Tube Assembly	4-7
XVI.	Removal & Replacement of the Water Pump Assembly	4-7
XVII.	Removal & Replacement of the Water Regulator Assembly - W/C	4-7
SECTION V -	MAINTENANCE & CLEANING INSTRUCTIONS	5-1
I.	General	5-1
II.	Icemaker	5-1
III.	CLEANING - Icemaker	5-1

TABLE OF CONTENTS (CONT'D.)

SECTION VI -	SERVICE DIAGNOSIS	6-1
I.	Icemaking - Refrigeration System	6-1
SECTION VII -	WIRING DIAGRAMS	7-1
	Wiring Diagram HC700 - Air-Cooled 115/208-220/60/3	7-2
	Wiring Diagram HC700 - Water-Cooled 115/208-220/60/3	7-3
	Wiring Diagram HC700 - Air-Cooled 115/208-230-60/1	7-4
	Wiring Diagram HC700 - Water-Cooled 115/208-230/60/1	7-5
SECTION VIII -	THE PARTS ILLUSTRATION AND PARTS LISTS	8-1
I.	General	8-1
II.	How to Use the Illustrations and Parts Lists	8-1
III.	How to Order Parts or Assemblies	8-1

LIST OF ILLUSTRATIONS

	Specifications	iv
Figure 1-1	Cube Deflector Bulb Holder and Bin Thermostat Capillary Tube	1-2
Figure 1-2	Installation Practice	1-5
Figure 2-1	Timer Cam Positions	2-1
Figure 3-1	Freezing Cycle	3-1
Figure 3-2	Harvest Cycle	3-2
Figure 4-1	Adjustment of the Temperature Control	4-1
Figure 4-2	Adjustment of the Timer & Switch Assembly	4-2
Figure 4-3	Removal of the Agitator Motor Assembly	4-3
Figure 5-1	START Positions for the Freeze/Harvest Cycles	5-2
Figure 7-1	Wiring Diagram HC700 Air-Cooled 115/208-220/60/3	7-2
Figure 7-2	Wiring Diagram HC700 - Water-Cooled 115/208-220/60/3	7-3
Figure 7-3	Wiring Diagram HC700 - Air-Cooled 115/208-230/60/1	7-4
Figure 7-4	Wiring Diagram HC700 - Water-Cooled 115/208-230/60/1	7-5
Figure 8-A	HC700 Modular Cuber Flow Chart	8-2
Figure 8-1	Model HC700 Modular Cuber	8-3
Figure 8-2	Major Assemblies - Air-Cooled	8-5
Figure 8-3	Major Assemblies - Water-Cooled	8-8
Figure 8-4	Freezer Assembly - Dual	8-11
Figure 8-5	Freezing Chamber Assembly	8-13
Figure 8-6	Freezing Chamber - Sump w/ Tubes	8-16
Figure 8-7	Dual Drive Spray Assemblies	8-18
Figure 8-8	Control Box Assembly	8-21
Figure 8-00	How To Use The Illustrated Parts List	8-23

SPECIFICATIONS HC700

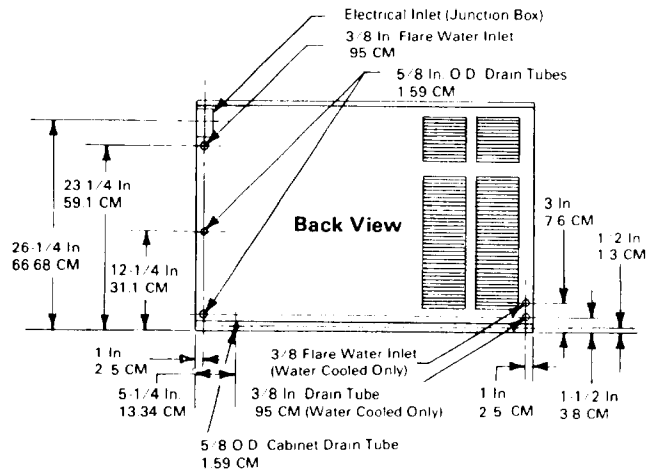
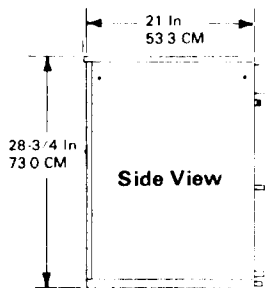
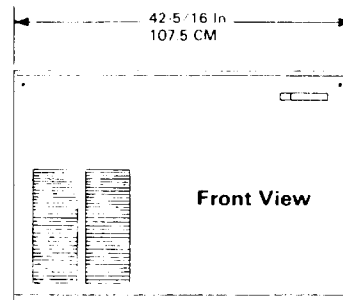
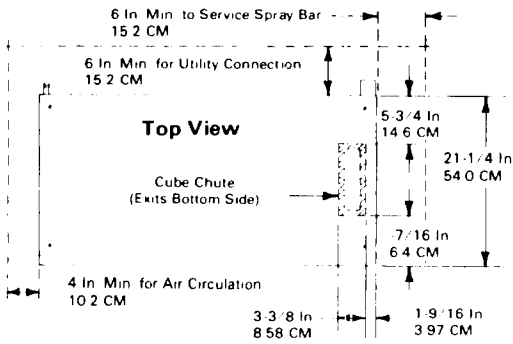

SPECIFICATIONS (CONT'D.)

MODEL HC700

Air-Cooled: Model HC700A

Water-Cooled: Model HC700W

Small, Medium, Large Cube Size

Electrical: 115/208-220/60/3
115/208-230/60/1

Est. Ship. Wt: 320 lbs.

FRONT SERVICE ACCESS PANEL

OPTIONALS

SPKMC35 - Stainless Steel Panels.

B40 Bin - 350 lbs. storage capacity.

B60 Bin - 550 lbs. storage capacity.

B80 Bin - 590 lbs. storage capacity.

B90 Bin - 590 lbs. storage capacity.

BX15 Bin Extension - 75 lbs.

BX25 Bin Extension - 150 lbs.

BX83 Bin Extension - 260 lbs.

BX85 Bin Extension - 560 lbs.

BX87 Bin Extension - 560 lbs.

KBT2 Bin Top.

SEE NAMEPLATE, shown at left, for electrical and refrigeration specifications. NAMEPLATE located on rear service panel.

Remove Left Side Panel to locate the Model Serial Number plate, shown below, on the Compressor base.

MODEL NUMBER		MOTORS	VOLTS	HP/WATT	F.L.A.	L.R.A.
SERIAL NUMBER		COMP.				
REFRIGERANT 12		DRIVE				
HEATER		FAN				
OZ	WATTS	OTHER				
TEST PRESSURE 140 LO - 235 HI						
A.C. SUPPLY VOLTAGE			WIRES	CYCLES	PHASE	
MAXIMUM FUSE SIZE	AMPS	MINIMUM CIRCUIT AMPACITY				
<small>QUEEN PRODUCTS DIVISION KING SEELY & SUTHERLAND THERMOS CO. 505 FRONT ST. W. ALBERT LEA, MN 56007</small>						

MODEL NUMBER	<small>QUEEN PRODUCTS DIVISION KING SEELY & SUTHERLAND THERMOS CO. 505 FRONT ST. W. ALBERT LEA, MN 56007</small>
SERIAL NUMBER	

We reserve the right to make product improvements at any time. Specifications and design are subject to change without notice.



This icemaker has been engineered to our own rigid safety and performance standards. The National Sanitation Foundation (NSF) seal, signifies that it is listed with the NSF and that it complies with the materials and construction standards of the NSF. In addition, the Underwriters Laboratories, Inc., (UL) Listing Mark and the Canadian Standards Association (CSA) Monogram, both signify that its construction and design have been inspected and tested by them. NSF, UL and CSA inspectors also periodically examine production icemakers at the factory, to assure continued compliance.

To retain the safety and performance built into this icemaker, it is important that installation and maintenance be conducted in the manner outlined in this manual.

SECTION I

GENERAL INFORMATION & INSTALLATION

I. INTRODUCTION

This manual provides specifications and the step-by-step procedures for the installation, startup and operation, and the maintenance and cleaning for the SCOTSMAN Model HC700 Modular Cuber.

The Model HC700 Modular Cubers are quality designed, engineered and constructed, and thoroughly tested icemaking systems, providing the utmost in flexibility to fit the needs of a particular user. Separate sections detail more specifically: General Information & Installation; Start Up Operation; Principles of Operation; Adjustment and Removal and Replacement Procedures; Maintenance and Cleaning Instructions; Service Diagnosis; Wiring Diagrams; and, the Illustrated Assemblies and Parts Lists.

DESCRIPTION

An attractive horizontal cabinet of leathergrain embossed steel with high gloss, charcoal brown baked enamel finish. Also, an optional stainless steel panel kit is available. These removable panels allow easy access to electrical and mechanical components for cleaning and maintenance.

SEALED REFRIGERATION SYSTEM

To provide quiet efficient operation of Ice-maker, the Compressor motor is internally spring-mounted. The Compressor motor is covered by a five year parts warranty.

STORAGE BIN & EXTENSIONS

Since the Model HC700, like other modular cubers in the SCOTSMAN line, does not have an attached ice storage bin, it is necessary to use an auxiliary bin. Modular systems combinations include: B40 Ice Storage Bin with 350 pounds (lbs.) capacity; B60 with 550 lbs.; B80 with 590 lbs.; B90 with 590 lbs.; and, bin extensions: BX15 with 75 lbs.; BX25 with 150 lbs.; and the KBT2 Bin Top used with BX83 with 260 lbs.; BX85 with 560 lbs., and BX87 with 560 lbs. Two HC700 Modular Cubers can be stacked to double ice production volume.

II. UNPACKING AND INSPECTION

1. Call your authorized SCOTSMAN Distributor or Dealer, for proper installation. He's listed under ICE MAKING

EQUIPMENT and MACHINERY in the yellow pages of the telephone book.

2. Visually inspect the exterior of the shipping container and skid and any severe damage noted, should be reported to the delivering carrier; and a concealed damage claim filed subject to internal inspection, with the carrier representative present.
3. Remove screws and shipping tape, and all panels, including the top, from the cabinet, and inspect for any concealed damage. Notify carrier of any concealed damage claims, as stated in step 2 above.
4. Remove all internal support packing, tape and wires, if any, in machinery compartment.
5. Check that refrigerant lines do not rub or touch lines or other surfaces, and that fan blades, if any, move freely.
6. Check that Compressors are snug on all mounting pads.
7. Remove optional Water Strainers from shipping bag, for installation in water supply line.
8. Untape and remove for installation, one plastic Base Drain and one electrical Conduit Box shipped from the factory taped to the top channel support above the Freezing Chambers.
9. Uncoil Bin Thermostat Tube and install Cube Deflector in Bin, see Figure 1-1.
10. Use clean damp cloth or disposable paper wiper to wipe clean the exterior surfaces of the cabinet.
11. SEE NAMEPLATE on the top rear, center service panel, and check that the location source voltage corresponds with the voltage specified on the nameplate.

CAUTION

Improper voltage supplied to the icemaker will void your parts replacement program.

12. Remove the Manufacturer's Registration Card from the front of the User's Manual and fill in all spaces including: Model Number and Serial Number taken from the Model-Serial Nameplate located on the left side, front part of the Chassis base, with Left Front

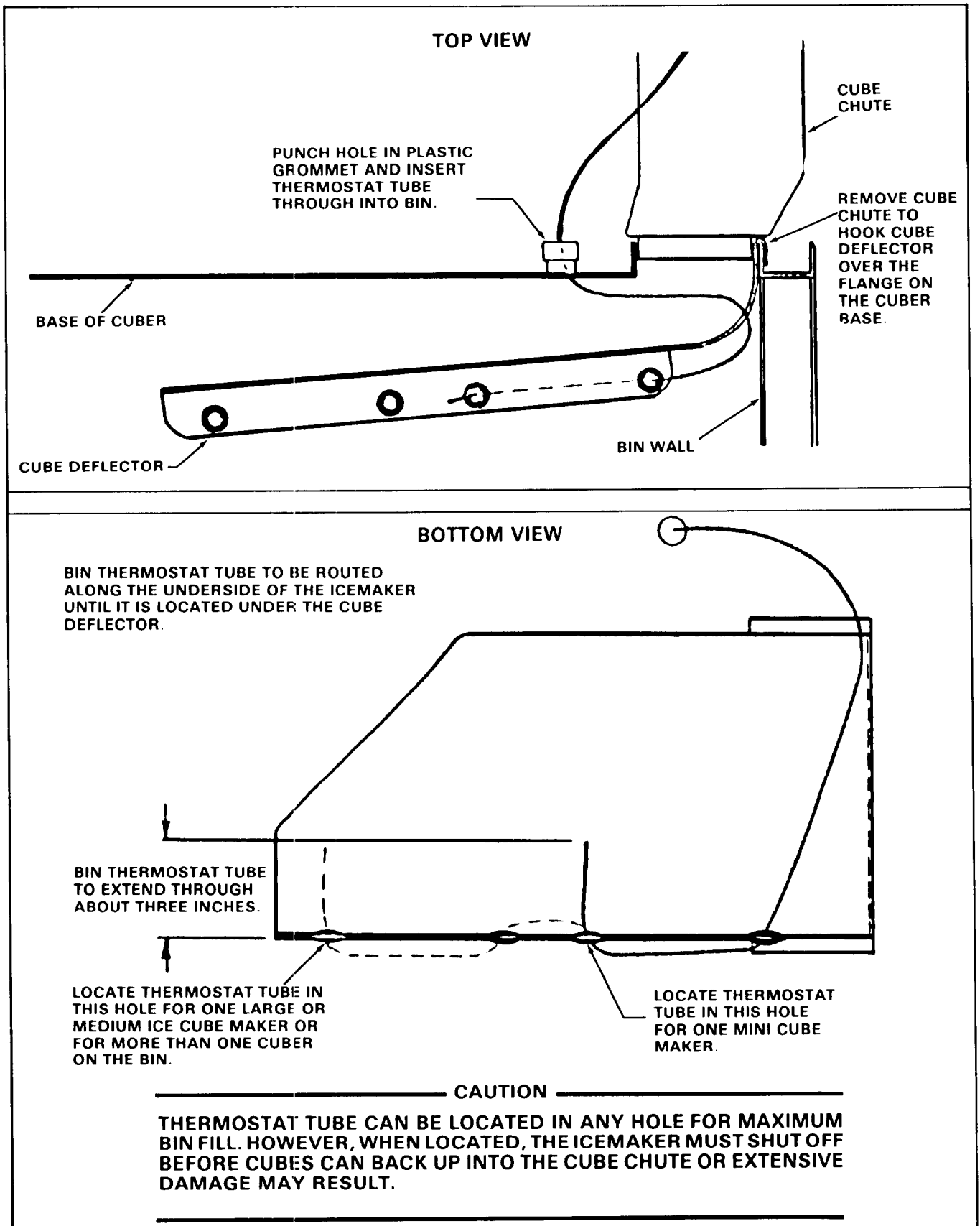

Figure 1-1. Cube Deflector Bulb Holder and Bin Thermostat Capillary Tube.

Panel removed. Forward the completed, self addressed, registration card to the SCOTSMAN factory.

III. LOCATION AND LEVELING

WARNING

This Modular Cuber is NOT designed for outdoor installations where air temperatures are below 50-degrees F., or above 100-degrees F., and water temperature is below 40-degrees F. or above 100-degrees F. Extended periods of operation at temperatures exceeding these limitations will constitute misuse, under the terms of the SCOTSMAN Manufacturer's limited warranty coverage.

1. Position the Modular Cuber and Bin, with or without Bin Extensions, in the selected permanent location.

NOTE

Prior consideration for location site shall include:

1. *Minimum room temperature 50-degrees F. and maximum room temperature 100-degrees F.*
2. *Water inlet temperatures: Minimum 40-degrees F. and maximum 100-degrees F.*
3. *Well ventilated location for air-cooled model, advising user to frequently clean Condenser, located directly behind Front Panel.*
4. *SERVICE ACCESS: Adequate space for all service connections, through the rear of the cabinet. A six inch minimum clearance at rear, left and front lowered panels, for routing cooling air drawn into and exhausted out of the compartment, to maintain proper condensing operation on air-cooled models.*

2. Level the modular cabinet in both the left-to-right and front-to-rear directions. The optional leveling legs on the Bins can be adjusted.

IV. ELECTRICAL CONNECTIONS

SEE NAMEPLATE for current requirements to determine wire size to be used for electrical hookup. The Cuber requires a solid earth ground wire. See Wiring Diagram.

Be certain the Cuber is connected to its own electrical circuit and individually fused. The maximum allowable voltage variation should not exceed ten percent of the nameplate rating, even under starting conditions. Low voltages can cause erratic operation and may be responsible for serious damage to the motor windings.

All external wiring should conform to the national, state and local electrical code

requirements. Usually electrical permit and services of a licensed electrician will be required.

V. WATER SUPPLY AND DRAIN CONNECTIONS

A. AIR-COOLED MODELS - The recommended water supply line is a 3/8-inch O.D. copper tubing. Connect to cold water supply line with standard plumbing fittings, with a shutoff valve installed in an accessible place between the water supply and the Cuber.

A wire mesh strainer is provided and must be installed with the cleanout plug down. Locate the strainer next to the male flare water inlet fitting, at the rear of the Chassis, with the arrow on the strainer positioned in the direction of the water flow. The strainer protects against large particles of rust, scale, etc., which may be loosened in the water supply line at the time of installation.

In some cases a plumbing permit and services of a licensed plumber will be required.

WARNING

DO NOT operate this Modular Cuber when the water supply is shut OFF, or is BELOW the recommended 20 PSIG water pressure. Press the Master ON-OFF toggle switch on the Control Box to OFF immediately.

B. WATER-COOLED MODELS: On Water-Cooled Models, a separate cold water supply inlet line is required, to be connected to a second 3/8-inch O.D. male flare fitting at the lower left rear of the Chassis. Additional drain lines are required to drain the water-cooled Condenser.

C. DRAIN CONNECTIONS: All drains are gravity type and must have a minimum of 1/4-inch fall per foot on horizontal runs. The drains to be installed to conform with the local plumbing code. Install separate drain line for discharge water from the water-cooled Condenser. Install a vertical open vent on drain line to ensure good venting. The drain receptacle should be an open, trapped or vented construction. See Figure 1-2.

Recommended Bin drain is 5/8-inch O.D. copper tubing and should be vented and run separately.

VI. INSTALLATION - OPTIONAL

Install optionals ordered with the HC700:

1. SPKMC1 - Stainless Steel Cabinet Panels.
2. B40 Bin - 350 lbs. storage capacity.
3. B60 - 550 lbs. storage capacity.

4. B80 Bin - 590 lbs. storage capacity.
5. B90 Bin - 590 lbs. storage capacity.
6. BX15 Bin Extension - 75 lbs.
7. BX25 Bin Extension - 150 lbs.
8. BX83 Bin Extension - 260 lbs.
9. BX85 Bin Extension - 560 lbs.
10. BX87 Bin Extension - 560 lbs.
11. KBT2 Bin Top.

VII. FINAL CHECK LIST

1. Is the Cabinet level?(IMPORTANT)
2. Have all kits, if any, been installed?
3. Have all electrical and piping connections been made?
4. Has the voltage been tested and checked against the nameplate rating?
5. Is the water supply line shutoff valve installed and open and electrical power supply wiring properly connected?
6. All masking tape removed from doors, panels, styrofoam blocks from top of Freezing Chamber.
7. Has the Cuber and the Bin been wiped clean with clean damp cloths?

8. Have the Compressor holddown bolts been checked, to be sure the Compressor is snug on the mounting pads?
9. Has the owner/user been given the User Manual and instructed on how to operate the icemaker and the importance of periodic maintenance?
10. Has the Manufacturer's Registration Card been properly filled out? Check for correct Model and Serial numbers from nameplate, then mail the completed card to the SCOTSMAN factory.
11. Check all refrigerant lines and conduit lines, to guard against vibration and possible failure.
12. Is there at least a six inch clearance behind and around the Cabinet, for all connections and for proper air circulation?
13. Is the Cuber in a room where ambient temperatures are a minimum of 50-degrees F. all year around?
14. Has the inlet water supply pressure been checked to ensure a minimum of 20 PSIG?
15. Has the owner been given the name and telephone number of the Authorized SCOTSMAN Distributor or Service Agency serving him?

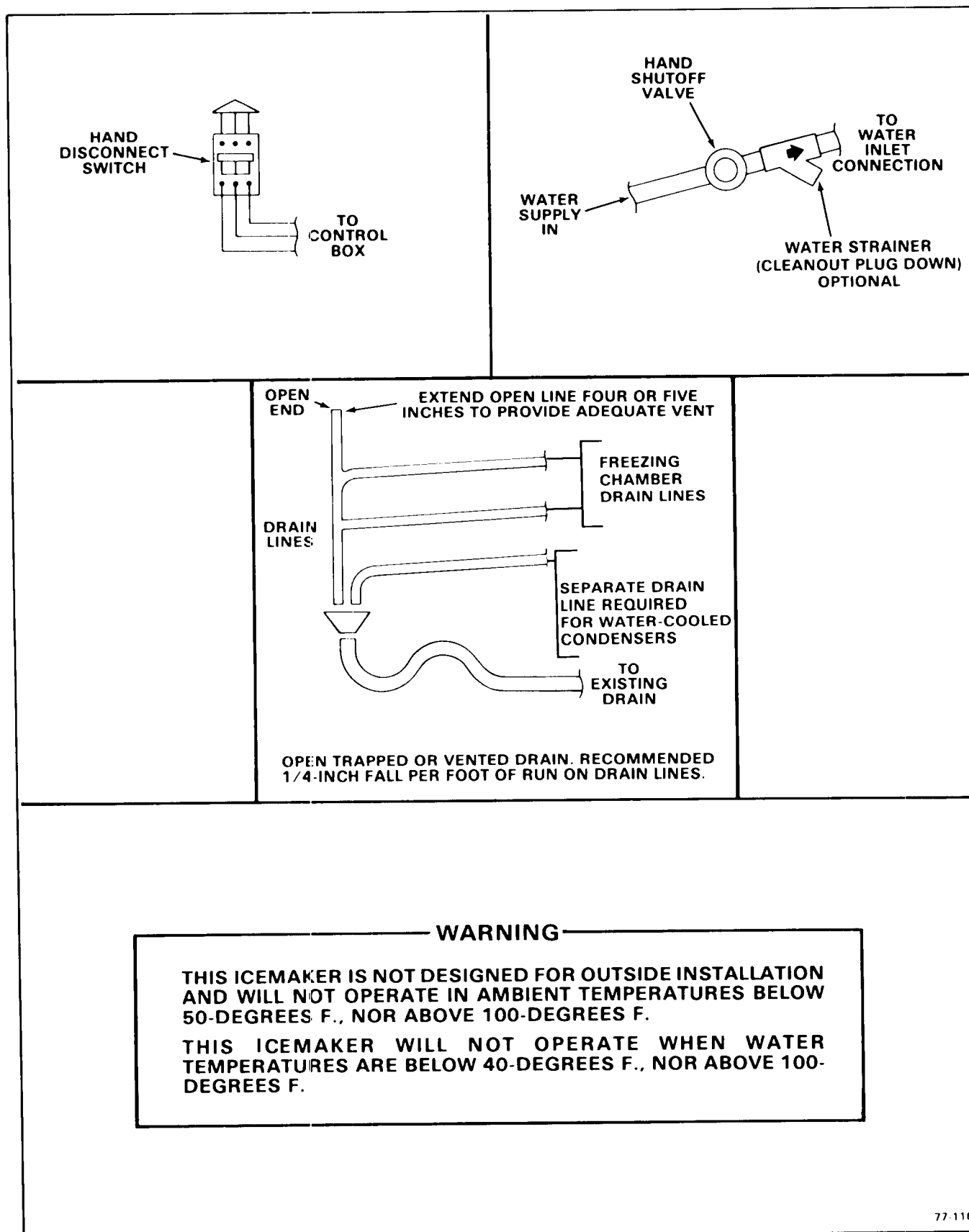

Figure 1-2. Installation Practice

SECTION II

OPERATING INSTRUCTIONS

I. START UP

1. Remove screws, the Top Panel and the Front Panel.
2. Check that the Master ON-OFF and Compressor ON-OFF toggle switches are OFF, on the front of the Control Box.
3. Rotate the shaft of the Timer & Switch Assembly protruding through the hole in the front Cover of the Control Box, **CLOCKWISE**, to start the Timer for filling the reservoir sump, in the Freezing Chamber, with water.

NOTE

*Slowly rotate the shaft **CLOCKWISE**, until the actuator arm on the microswitch drops off of the outer cam into the cam slot. An audible click can be heard, but in a noisy area, look at the cam and switch to observe the event. See A, Figure 2-1.*

4. Move the Master ON-OFF toggle switch to the ON position.

NOTE

*Observe that the Water Inlet Solenoid valve **OPENS** and inlet water flows from the valves through tubing and can be seen flowing to the Defrost Water Tube, at the top rear of each Freezing Chamber, where the water then flows around the inverted ice cube cups and drains into the Freezing Chamber sump. Excess water is overflowed through the standpipe and drain tube. This cycle will take about three minutes, when the Timer will **CLOSE** the Water Inlet Solenoid Valve.*

5. Repeat step 3.
6. After completion of the second Harvest Cycle, move the Compressor ON-OFF toggle switch to the ON position.

NOTE

1. *During **START UP**, advancing two Harvest Cycles, allows a check that: the Water Inlet Solenoid Valve operate properly; inlet water can be observed flowing; the sumps are filled with water in preparation for the Freezing Cycle; and, checks the function of the overflow and drains.*
2. *The Water Pumps operate during the defrost Harvest Cycle, Factory testing proved faster defrost and increased ice capacity with continuous operation of the Water Pumps.*

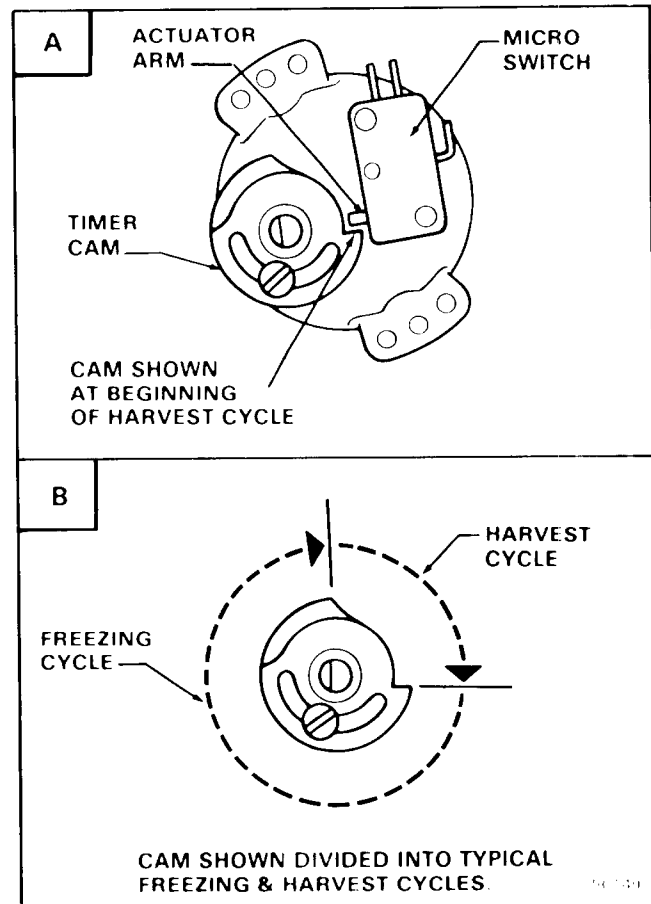

Figure 2-1. Timer Cam Positions.

7. Temporarily remove Cube Chute for these operational checks.
8. Check that the plastic Curtains hang evenly and vertically, to prevent loss of water during the Freezing Cycle.

NOTE

The Timer dial does not rotate at the end of the Harvest Cycle, it is started later by the Cube Size Control, in the Control Box.

9. Check operation of Freezing Cycle:
 - a. Compressors are operating.
 - b. Agitator Motor is operating, as seen by

Fan rotating on top of upper Freezing Chamber.

- c. Water Pumps are operating, as seen at Tygon Tubes on Pump and looking at water being sprayed into inverted ice cube cups, from rotating Spray Bars, seen inside Freezing Chamber.
- d. Icemaking process begins: feeling inside ice cube cups reveals cold temperatures and very shortly ice begins to form.

NOTE

Freezing time will range between 20 to 30 minutes in a 70-degree F. ambient temperature. Longer time, for temperatures above 70-degrees F. and shorter time required when temperatures are below 70-degrees F. Average complete cycle range is about 17 to 25 minutes.

WARNING

DO NOT operate this Icemaker when the water supply is shut OFF, or is BELOW the recommended 20 PSI water pressure. Move the Master ON-OFF toggle switch to OFF, immediately.

10. Replace the plastic Cube Chute, before Harvest Cycle begins.
11. Observe first ice cube harvest:
 - a. Check size of ice cubes: when too small after a second harvest, refer to procedure IV-II, for adjustment to Cube Size Control to increase size of ice cube.

NOTE

Normal cube size is with a one-quarter inch depression in the crown.

- b. Check texture of ice cubes: when partially cloudy throughout, suggests icemaker operating short of water, near end of freezing cycle, or possibly an extreme problem water condition, where in filtering or purifying equipment is recommended. Contact SCOTSMAN - Queen Products Division, Service Department, Albert Lea, Minnesota, for further details.

12. With the icemaker in the Harvest Cycle, hold ice against the Bin Thermostat Control bulb to test shutoff, which should cause the icemaker to shut OFF at the end of the Harvest Cycle.

NOTE

Within minutes after the ice is removed from the sensing bulb, the bulb will warm up and cause the icemaker to restart. This control is factory set and should not be reset until testing is performed. Normal setting is about 35-degrees F. CUT-OUT and 39-degrees F. CUT-IN.

13. Install refrigerant service gauges on the high side and low side Schrader valve fittings and check the Compressor head pressure and back pressure.

NOTE

1. *Air-Cooled Models: Head pressure after 20 minutes of Freezing Cycle, at 70-degree F. ambient temperature, will be about 135 PSIG. The back pressure equalizes during hot gas defrost and gradually pulls down to about four PSIG, just before Harvest Cycle. Higher ambient temperatures and dirty Condenser will cause higher pressure.*
2. *Water-Cooled Models: Water Regulator Valves are factory set at 135 PSIG. Check the gauge indication and adjust, if necessary. Back pressure will operate the same as our Air-Cooled Models.*
14. Replace Control Box Cover and all service panels.
15. Remove refrigerant service gauges.
16. Thoroughly explain to the owner/user the significant specifications of the Icemaker, the start up and operation, going through the procedures in the operating instructions. Answer all questions about the Icemaker, by the owner; and, inform the owner of the name and telephone number of the authorized SCOTSMAN Distributor, or Service Agency serving him.

SECTION III

PRINCIPLES OF OPERATION - How It Works

I. FREEZING CYCLE

Water from the sump in the reservoir of the Freezing Chamber is pumped to a rotating Spray Bar Assembly, which is powered by the Agitator Motor drivemotor on top of the upper Freezing Chamber. Each Spray Bar Assembly has ten jets through which water is uniformly sprayed into the inverted ice cube cup molds of the Freezing Chamber Evaporator. See Figure 3-1. At the beginning of the Freeze Cycle, the electrical circuit is completed to the Compressor, Water Pump, and the coil of the Finish Relay. The Water Pump operates continuously during the Freeze Cycle, through contacts of the Finish Relay. In Water-Cooled models water also flows through the Condenser and out the drain. While in the Condenser, water removes heat from the refrigerant and allows the refrigerant to condense from a gas to a liquid.

Refrigerant is compressed in the Compressor and discharged into the Condenser as a high

pressure, high temperature gas. The refrigerant is cooled and condensed by either air or water and condenses to a high pressure, high temperature liquid. This liquid refrigerant, then passes through a small capillary tube where the temperature and pressure of the liquid refrigerant are lowered. The low pressure, low temperature liquid refrigerant, then enters the Evaporator. The refrigerant is warmed by water being sprayed against the Evaporator and begins to boil off, to become a gas. The refrigerant next travels through the Accumulator, where any remaining liquid refrigerant then returns to the Compressor as a low pressure, low temperature gas, and the cycle starts again.

During the Freezing Cycle, both the Water Inlet Solenoid Valve and the Hot Gas Solenoid Valve are CLOSED.

When the ice cubes are about three-quarters formed, the Cube Size Control bulb located on the suction line coming out of the Evaporator

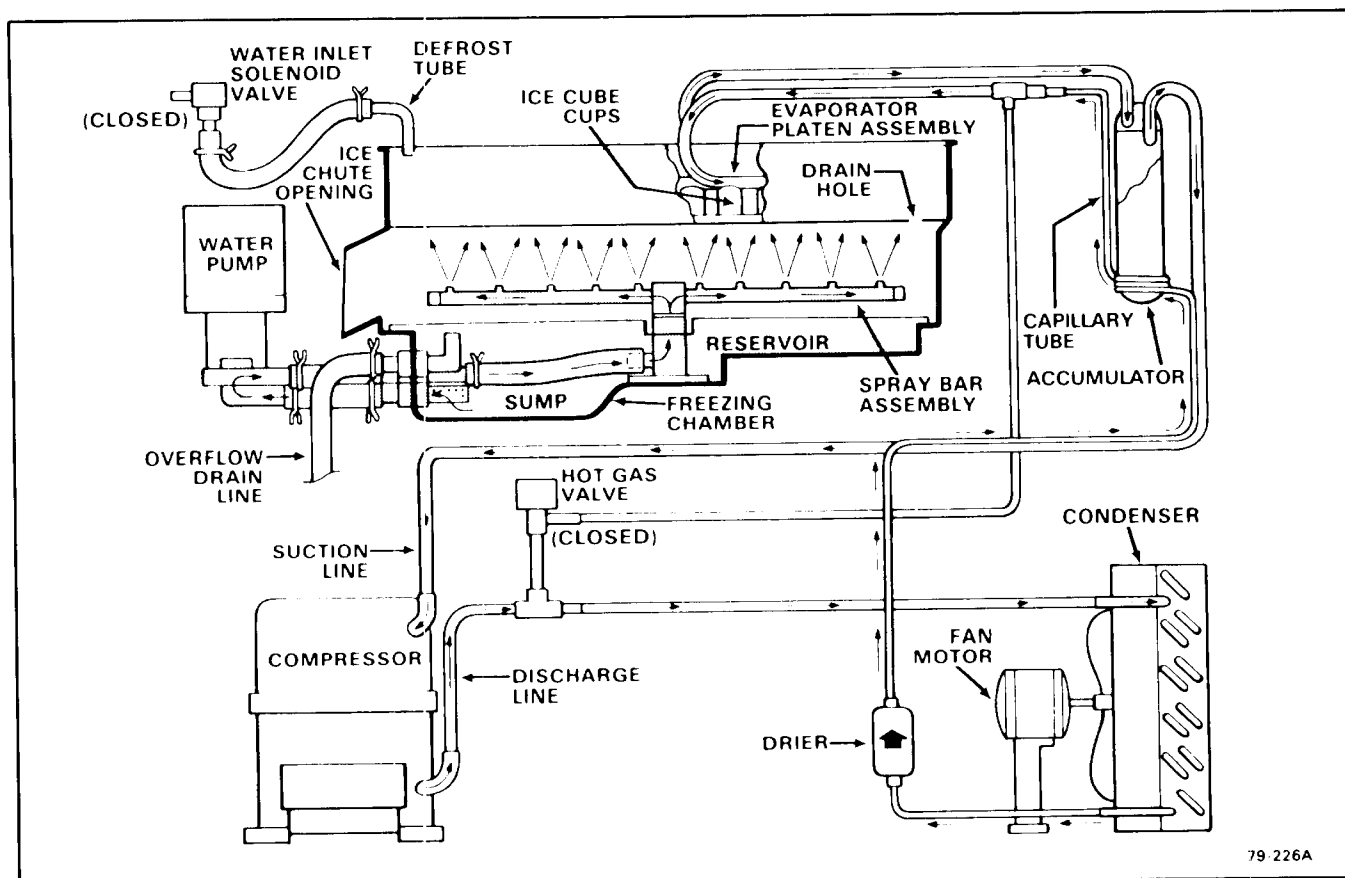

Figure 3-1. Freezing Cycle.

platen assembly, will sense the temperature at which it is preset to CLOSE. This will complete the electrical circuit to the Timer. The Timer then controls the remainder of the cycle.

The Timer will keep the Icemaker operating in the Freezing Cycle for the next six minutes. This will give the cubes time to fully form. After six minutes, the Timer will switch the Icemaker into the Harvest Cycle, through the contacts of the Timer Assembly microswitch.

II. HARVEST CYCLE

When the Timer switches the Icemaker into the Harvest Cycle, hot gas being discharged from the Compressor is diverted from the Condenser through the Hot Gas Solenoid Valve into the Evaporator. During this cycle, the hot gas circulates from the Compressor to the Evaporator and back again, bypassing the Condenser and capillary tube. In the electrical circuit, the Compressor is operating and both the Water Inlet Solenoid Valve and the Hot Gas Solenoid Valve are energized. See Figure 3-2.

Opening the Water Inlet Solenoid Valve, allows a fresh water supply to be discharged into the top of the Evaporator platen assembly. The finished ice cubes are released from the Evaporator, by the warming effect of the hot gas flowing through the Evaporator tubes and the water flow around the ice cube molds. The released ice cubes drop into the inner bottom of

the Freezing Chamber and pushed by the rotating Spray Bar Assembly out the slightly slanted ice chute opening, down the plastic Cube Chute and into the ice storage bin. At the end of the Harvest Cycle, the Timer cam will push the actuator arm of the microswitch IN. If the Bin Thermostat is still CLOSED, a whole new cycle will begin. If the Bin Thermostat is OPEN, the icemaker will shut OFF at this time.

III. COMPONENT DESCRIPTIONS

A. BIN THERMOSTAT CONTROL

The Bin Thermostat Control is located in the right side of the gusset in the front upper corner of the Chassis frame. The sensing capillary tube of the control is routed downward and into the ice storage Bin. The capillary tube is threaded through the grommets holes of the combination cube deflector and thermostat bulb bracket. The Bin Thermostat Control functions to automatically shut OFF the Icemaker, when the ice storage Bin is filled and ice contacts the capillary tube. It also signals the RESTART of the Icemaker when the capillary tube starts to warm up, after ice has been removed from the Bin.

NOTE

Altitude adjustment should ONLY be performed on Icemakers installed at 2000-foot level locations and

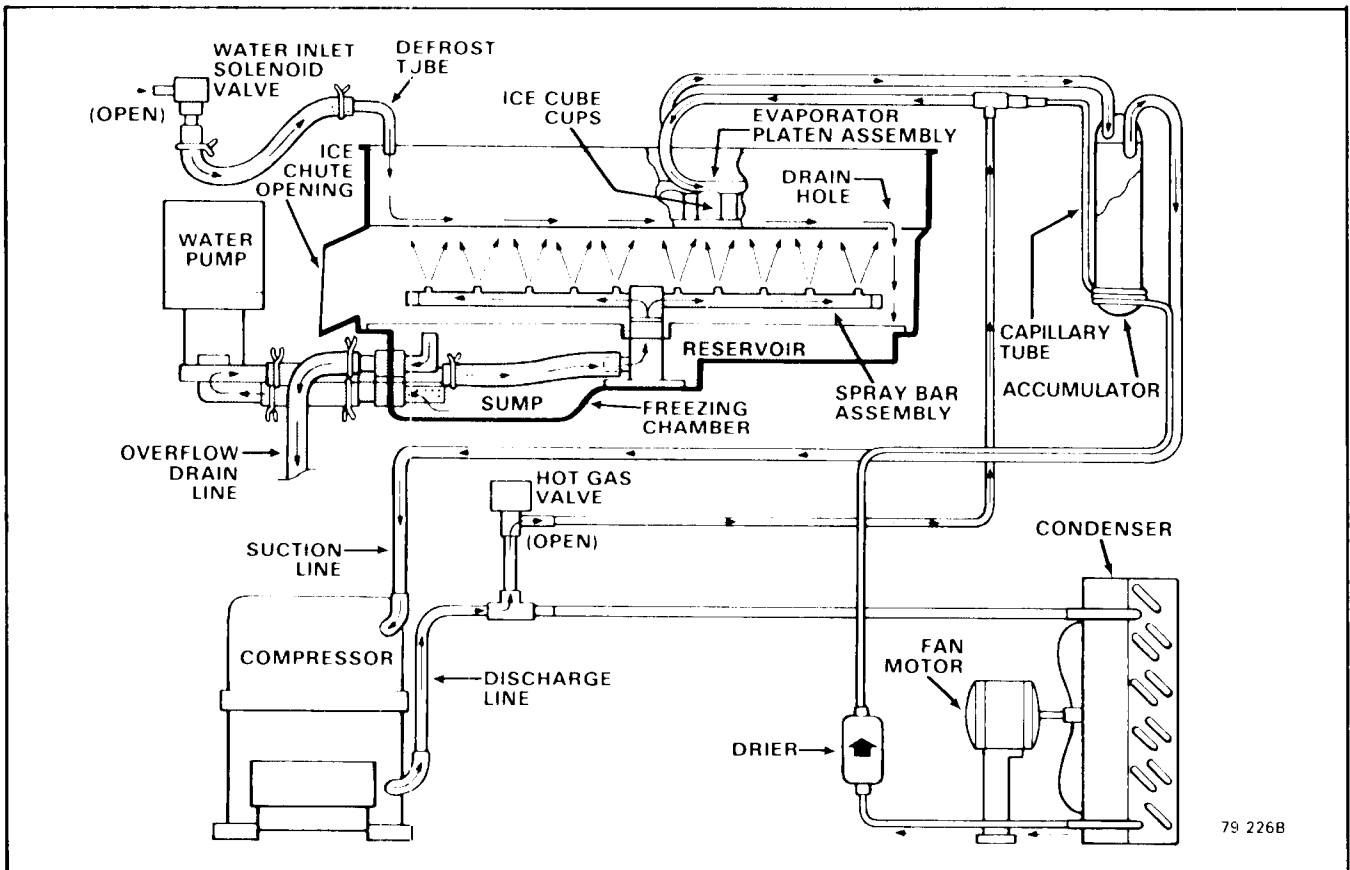

Figure 3-2. Harvest Cycle.

ABOVE, and adjust only in increments of one-fourth turn of a screw at a time.

B. COMPRESSOR START RELAY

The Compressor Start Relay functions to carry the Compressor line current. The relay is wired so any control in the pilot circuit, such as the Bin Thermostat, Low Pressure - and High Pressure Controls, etc., will cause the relay holding coil to be de-energized, when the control contact OPENS, thereby breaking the circuit to the Compressor through the relay points.

C. CUBE SIZE CONTROL

The temperature sensing Cube Size Control affects the length of the Freezing Cycle prior to initiating the Finishing Timer. The Cube Size Control closes its contacts when the Evaporator reaches a preset temperature, starting the Finishing Timer. A variation in either ambient air or incoming water temperature will affect the efficiency of the refrigeration system. This will vary the length of time it takes the Evaporator to reach the temperature at which the Cube Size Control is preset to CLOSE; which, in turn, will affect the overall cycle time.

NOTE

Be sure to refer to procedure IV-II, Adjustment of the Cube Size Control, BEFORE attempting to adjust the control.

D. FINISH RELAY

The multi-function, three pole, double-throw, plug-in relay is installed directly into a receptacle on the printed circuit board in the Control Box. The relay functions, in part, to by-pass the Bin Thermostat Control, to prevent the Icemaker from shutting OFF, when a filled-bin condition occurs, during the Freezing Cycle. The by-pass action serves to ensure full-sized ice cubes with each Harvest Cycle; and, to prevent short cycling on the Bin Thermostat Control.

E. FINISHING TIMER - Timer & Switch Assembly

The function of the Finishing Timer begins when activated by the Cube Size Control. The Timer controls a fifteen minute dual function: eleven and one-half minutes are programmed to finish freezing the ice cubes and the final three and one-half minute portion is for the defrost operation and harvest of the ice cubes. All electrical circuitry is connected through the printed circuit board and the Finishing Timer and shunted by the single-pole, double-throw microswitch to either the Freezing Cycle or the Harvest Cycle. The microswitch is

actuated by a Cam Assembly directly connected to the Timer Motor. The Timer Cam can be adjusted to vary the defrost timer as required.

F. HIGH PRESSURE CONTROL - Air-Cooled Model

The High Pressure Control, a safety Control, is factory set at 300 PSIG. The control functions as a precautionary device, to shut OFF electrical power to the Icemaker, when extreme pressures occur in the refrigeration system. In addition to being a manual reset control, there is an adjusting screw for raising or lowering the CUT-IN pressure.

G. HIGH PRESSURE CONTROL - Water-Cooled Model

The High Pressure Control, a safety control, is factory set at 250 PSIG. The control functions as a precautionary device, to shut OFF electrical power to the Icemaker, should a loss of water occur to the water-cooled Condenser. In addition to being a manual reset Control, there is an adjusting screw for raising or lowering the CUT-IN pressure.

H. HOT GAS SOLENOID VALVE

The Hot Gas Solenoid Valve functions only during the Harvest Cycle, to divert the hot discharge gas from the Compressor, by-passing the Condenser and capillary tube, for direct flow to the Evaporator Platen Assembly to release ice cubes from the inverted ice cube molds. The Hot Gas Solenoid Valve is comprised of two parts, the Body & Plunger and the Coil & Frame assemblies. Installed in the discharge line of the Compressor, the energized solenoid coil lifts the valve stem within the valve body to cause the hot discharge gas to be diverted when the Finishing Timer has advanced to the start of the Harvest Cycle.

I. SPRAY BAR ASSEMBLY

The Spray Bar Assemblies are rotated by the Agitator Motor, a small drivemotor mounted on top of the upper Freezing Chamber; and, designed to channel recirculating water to small jets for uniformly spraying water into the inverted ice cube cups. The Celcon material, used in fabricating the Spray Bar parts, is not subject to chemical attack by either acidic or alkaline materials at low temperatures or at high temperatures. Because of the smooth non-porous surface of the Celcon material Spray Bar, foreign materials have difficulty trying to adhere to these surfaces, thereby, reducing the usual frequency of cleaning procedures.

NOTE

Refer to procedure V-III, CLEANING - Icemaker; and, for problems requiring removal of parts refer to procedure IV-XV, for details for removing the Spray Bar Assembly.

J. WATER INLET SOLENOID VALVE

The Water Inlet Solenoid Valve functions only during the Harvest Cycle, when it is energized to permit a metered, gallon-per-minute rate of incoming water, to flow through the Defrost Tube onto the top of the plastic Platen Assembly, assisting in the harvest of ice cubes. The water drains through holes in the Platen Assembly into the Reservoir in the lower section of the Freezing Chamber; and there, the water is recirculated through the Water Pump for return to the Spray Bars.

K. WATER REGULATOR VALVE - Water-Cooled Model

The Water Regulator Valve functions to maintain a constant Compressor head pressure, by regulating the amount of incoming water flow through the Condenser, on water-cooled models. The valve operates through the refrigerant system high side pressure.

Rotating the adjusting screw, located on top of the valve, can INCREASE or DECREASE the water flow through the water-cooled Condenser, which in turn, will DECREASE or INCREASE the Compressor operating head pressure.

NOTE

When installing a replacement Water Regulator Valve, be sure the replacement valve is installed with the arrow positioned in the direction of the water flow.

REFRIGERANT CHARGE

MODEL	HC700 Refrig. Chg.
Air-Cooled	33 oz. R-12 (Approx.)
Water-Cooled	33 oz. R-12 (Approx.)

NOTE

Always CHECK NAMEPLATE on individual Icemaker for specific refrigerant charge, BEFORE charging the refrigeration system. The above listed refrigerant charges are approximate charges for the HC700 Cubers, however it is important to CHECK NAMEPLATE for each Icemaker, especially when there are different Compressors.

SECTION IV

ADJUSTMENT & REMOVAL & REPLACEMENT

The procedures provided in this Section are arranged in alphabetical order, to make specific Adjustment and Removal and Replacement information easy to locate.

Read the instructions thoroughly before performing any Adjustment or Removal and Replacement Procedures.

I. ADJUSTMENT OF THE BIN THERMOSTAT CONTROL

The control for the Bin Thermostat is the Temperature Control, located in the right side of the gusset in the front upper corner of the Chassis frame.

See Figure 4-1 for location and direction of rotation, clockwise (CW) or counterclockwise (CCW), of the adjusting screws on the Temperature Control, the adjustment is to be performed.

WARNING

The adjusting screws on the Temperature Control device have very sensitive response to adjustment. DO NOT attempt to adjust the screw until after thoroughly reading and understanding the following instructions and illustration. Over-adjusting or erratic guessing, can foul the instrument and cause ultimate delay and part replacement, WHICH COULD HAVE BEEN PREVENTED.

II. ADJUSTMENT OF THE CUBE SIZE CONTROL

CAUTION

BEFORE performing actual adjustment to the Cube Size Control, check other possible causes for

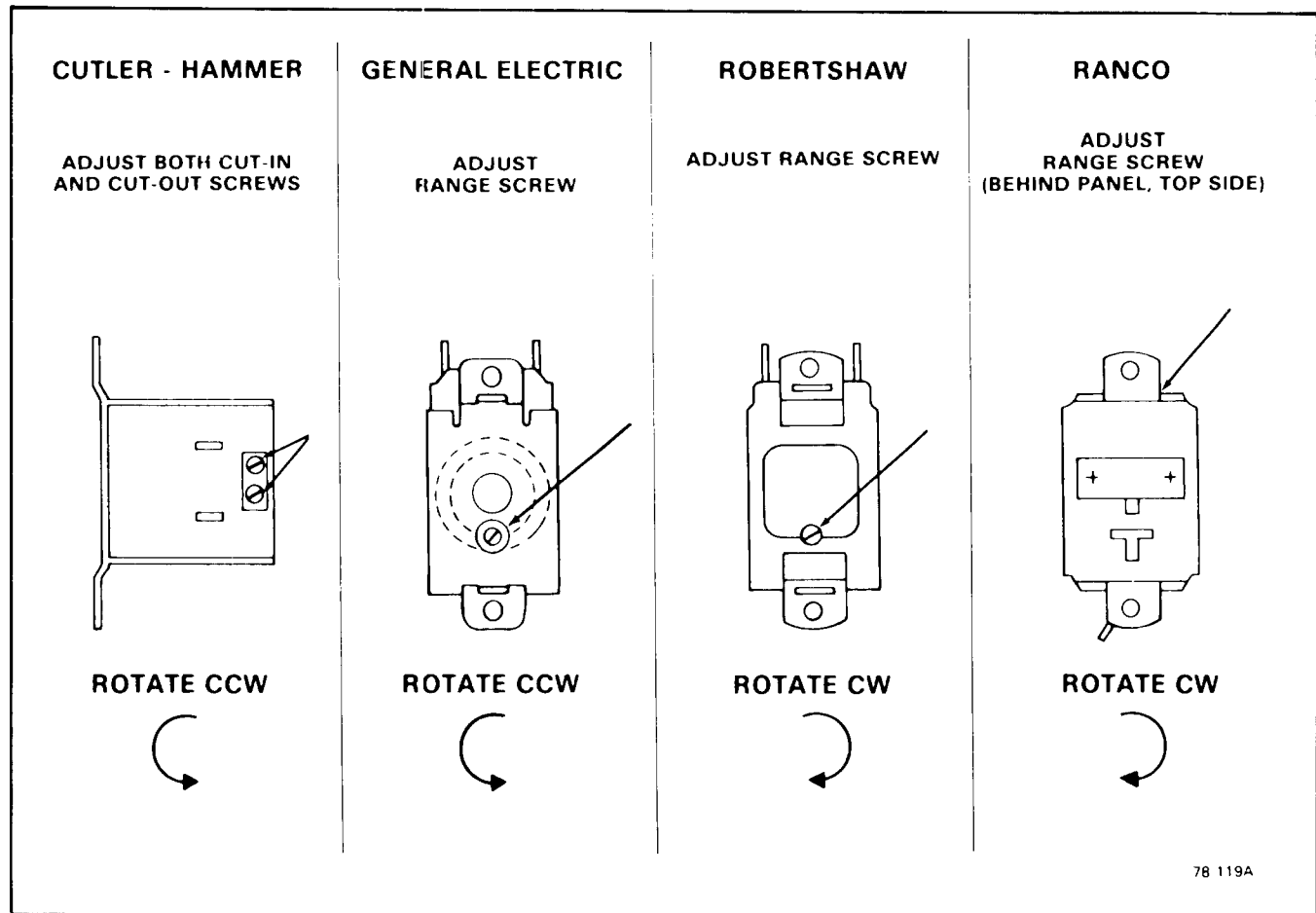

Figure 4-1. Adjustment of the Temperature Control.

cube size problems, refer to Section VI, **SERVICE DIAGNOSIS** for problem review and analysis.

DO NOT perform adjustment when a new Cube Size Control is installed, until the control bulb has been properly installed in the tube well, on the refrigerant tube of the Platen Assembly and the icemaker has progressed through several complete freezing and harvest cycles, to observe size and quality of ice cubes and whether or not a cube size problem exists.

As a reverse acting temperature control, adjustment on the Cube Size Control is performed to either cause larger sized ice cubes or smaller sized ice cubes to be produced.

A. To Produce LARGER Sized Ice Cubes:

1. Locate the Cube Size Control, in the left side of the gusset in the front upper corner of the Chassis frame.
2. Rotate the adjusting screw one-eighth of a turn **CLOCKWISE** toward **COLDER**.
3. Observe size of ice cubes in next two ice cube harvests and repeat step 2 above, in one-eighth turn increments, until desired ice cube size is achieved.

B. To Produce SMALLER Sized Ice Cubes:

1. Locate the Cube Size Control, in the left side of the gusset in the front upper corner of the Chassis frame.
2. Rotate the adjusting screw one-eighth of a turn **COUNTERCLOCKWISE** toward **WARMER**.
3. Observe size of ice cubes in next two ice cube harvests and repeat step 2 above, in one-eighth turn increments, until desired ice cube size is achieved.

III. ADJUSTMENT OF THE TIMER & SWITCH ASSEMBLY

The Timer & Switch Assembly is factory set, so that one complete revolution of the cam on the Timer represents fifteen minutes. Eleven and one-half minutes comprise the freezing cycle event during cam rotation, and the final three and one-half minutes program the defrost and harvest cycle. Rotating the shaft of the Timer Cam, **CLOCKWISE** will allow positioning the actuator arm of the microswitch on the cam at the selected start position for either the freezing cycle or harvest cycle, as required, during the **START UP** procedures and in the **CLEANING** instructions. Rotating the shaft **COUNTERCLOCKWISE** will unscrew the shaft from the threaded stud on the Timer Cam.

To Adjust the Timer Switch Assembly:

A. HARVEST CYCLE: Slowly rotate the shaft of the Timer & Switch Assembly, located in

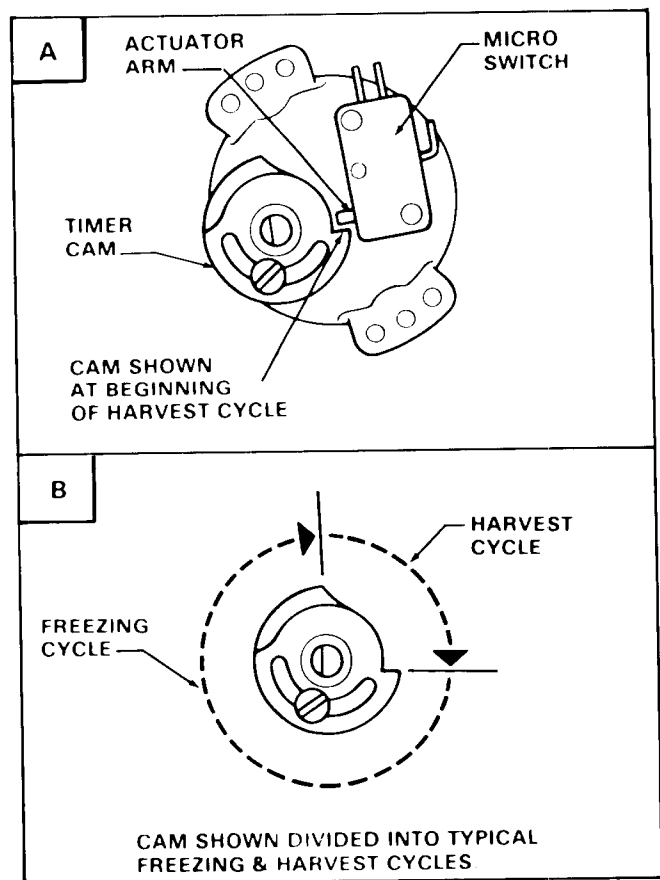

Figure 4-2. Adjustment of the Timer & Switch Assembly.

the hole in the front of the Control Box Cover, **CLOCKWISE**, until the actuator arm on the microswitch drops off of the outer cam into the cam slot. An audible click can be heard, but in a noisy area, look at the cam and switch to observe the event. See Figure 4-2.

B. FREEZING CYCLE: Slowly rotate the shaft of the Timer & Switch Assembly, located in the hole in the front of the Control Box Cover, **CLOCKWISE**, until the actuator arm on the microswitch rides up out of the cam slot to the start of the surface of the outer cam.

IV. ADJUSTMENT OF THE WATER REGULATOR ASSEMBLY - WATER-COOLED MODELS

The correct Compressor head pressure on Water-Cooled Models is 135 PSIG. Adjusting the Water Regulator Valve increases or decreases the rate of flow of water, through the Water-Cooled Condenser; which increases or decreases the affected temperature/pressure of the Compressor head pressure. **INCREASED** water flow, results in **DECREASED** or **LOWER** head pressure; while, **DECREASED** water flow, results in **INCREASED** or **HIGHER** head pressure.

To adjust the Water Regulator Assembly:

A. To INCREASE the head pressure: Rotate the adjusting screw **IN**, or **CLOCKWISE**.

B. To DECREASE the head pressure: Rotate the adjusting screw OUT, or COUNTER-CLOCKWISE.

C. Check change in Compressor head pressure, and repeat step A or B as necessary, to achieve desired operating head pressure.

WARNING

Be sure the electrical power supply and the water supply are OFF BEFORE starting any of the following REMOVAL AND REPLACEMENT procedures as a precaution to prevent possible personal injury or damage to equipment.

V. REMOVAL AND REPLACEMENT OF THE AGITATOR MOTOR ASSEMBLY

NOTE

The Agitator Motor in the HC-700 Cuber, is installed on top of the upper Freezing Chamber.

A. To remove the Agitator Motor Assembly:

1. Remove screws and the Top Panel and Front Panel to gain access to the Agitator Motor.
2. Tilt the top of the plastic Cube Chute forward slightly, then, lift the Cube Chute up for removal.

3. Remove three U-Type Clips and the plastic Curtain Assembly.
4. Reach through the ice chute opening in the upper Freezing Chamber and feel for the Spray Bar.
5. Move hand to the center hub and rotate the Spray Bar, so one end is aligned with the ice chute opening.
6. Lift the Spray Bar up, off of the jet bearing hub, then, remove the Spray Bar through the ice chute opening.
8. Disconnect electrical leads and ground wire from terminals on the Agitator Motor.
9. Reach through the same ice chute opening, as before, and grasp the top Drive Fork with one hand, and the Agitator Motor Fan, on top of the upper Freezing Chamber, with the other hand. See Figure 4-3.
10. Hold the Fan blades still and rotate the left-hand thread Drive Fork to the right, COUNTERCLOCKWISE, and unscrew the Drive Fork from the Agitator Motor.
11. Remove four screws and lift the Agitator Motor out the top of the upper Freezing Chamber.

B. To replace the Agitator Motor Assembly, reverse the removal procedure.

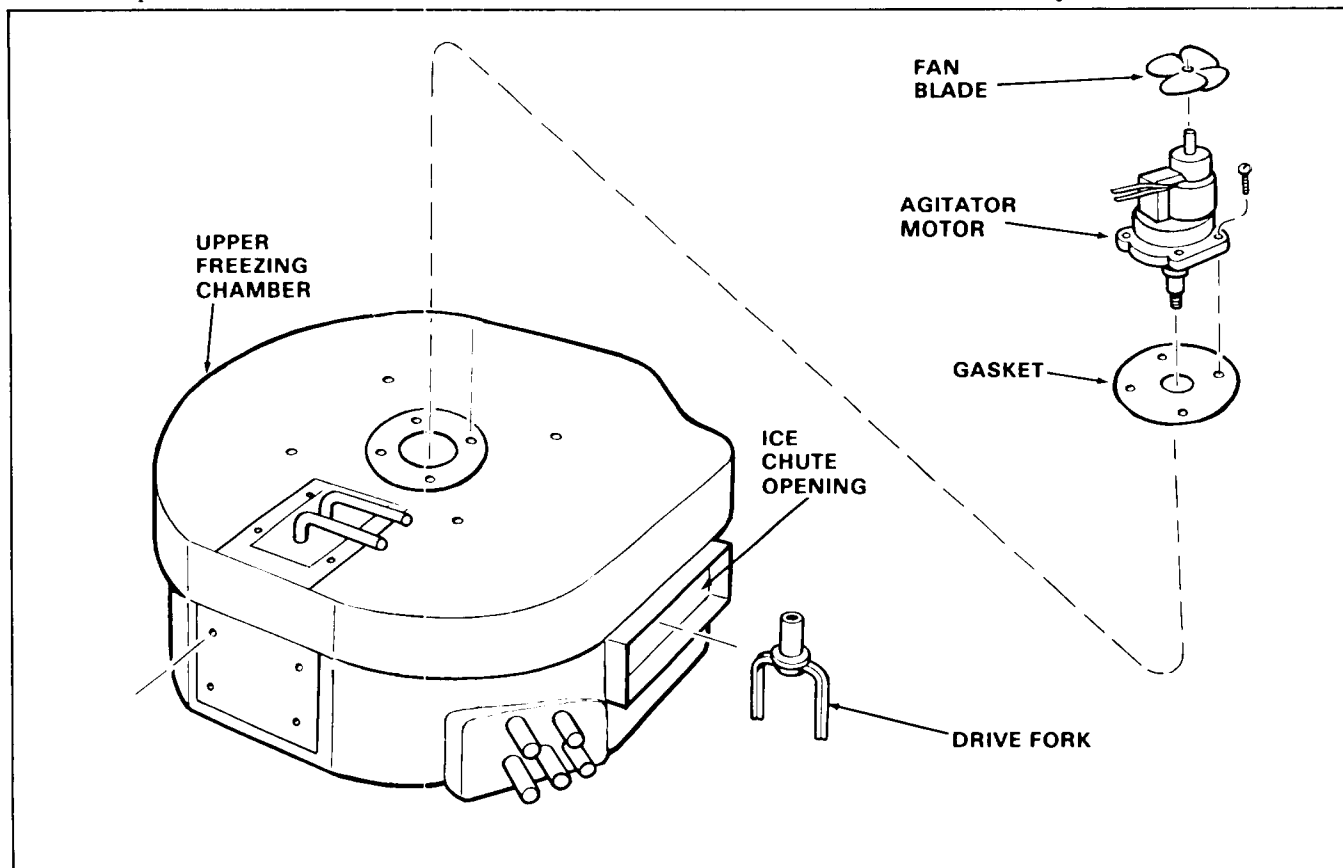

Figure 4-3. Removal of the Agitator Motor Assembly.

VI. REMOVAL AND REPLACEMENT OF THE BIN THERMOSTAT CONTROL

A. To remove the Bin Thermostat Control:

1. Remove screws and the Front Panel to gain access to the Bin Thermostat Control.
2. Trace capillary tube, from the Bin Thermostat Control, down to the Cube Deflector.
3. Carefully remove the capillary tube from the bulb holder holes on the side of the Cube Deflector.
4. Carefully withdraw the capillary tube from the Bin, up through the Chassis Base.
5. Remove electrical leads from the Bin Thermostat Control.
6. Remove screws and the Bin Thermostat Control.

B. To replace the Bin Thermostat Control, reverse the removal procedures.

VII. REMOVAL AND REPLACEMENT OF THE COMPRESSOR ASSEMBLY

NOTE

Always install a replacement Drier, anytime the sealed refrigeration system is opened. Do not replace the Drier until all other repair or replacement has been completed.

A. To remove the Compressor Assembly:

1. Remove screws and the Top, Front and Left Side Panels.
2. Bleed off or blow the refrigerant charge through the Schrader valve.
3. Remove the cover from the terminal box on the Compressor; then, remove three screws and electrical leads from the Compressor.
4. Unsolder the refrigerant suction line and the discharge line from the Compressor.
5. Unsolder the process header from the Compressor and retain for installation on the replacement Compressor.
6. Remove four bolts and washers which secure the Compressor to the Chassis mounting base.
7. Slide and remove the Compressor from the Cabinet.

B. To replace the Compressor Assembly, reverse the removal procedure.

VIII. REMOVAL AND REPLACEMENT OF THE CONDENSER - AIR-COOLED MODELS

NOTE

Always install a replacement Drier, anytime the sealed refrigeration system is opened. Do not replace the Drier until all other repair or replacement has been completed.

A. To remove the Condenser:

1. Remove screws and the Left Side Panel and Front Panel.
2. Bleed off or blow the refrigerant charge through the Schrader valve.
3. Unsolder and disconnect refrigerant lines from the Condenser.
4. Unsolder and remove the Drier from the refrigerant lines connecting to the Condenser.
5. Remove screws, lockwashers and the Condenser from the Chassis base.

B. To replace the Air-Cooled Condenser, reverse the removal procedure.

IX. REMOVAL AND REPLACEMENT OF THE CONDENSER - WATER-COOLED MODELS

NOTE

Always install a replacement Drier, anytime the sealed refrigeration system is opened. Do not replace the Drier until all other repair or replacement has been completed.

A. To remove the Condenser:

1. Remove screws and the Front Panel.
2. Bleed off or blow the refrigerant charge through the Schrader valve.
3. Check to be sure building source water inlet supply shutoff valve to rear of Chassis is OFF.
4. Disconnect water inlet supply line at the left bottom rear of Chassis.
5. Disconnect Water-Cooled Condenser inlet water line at the Water Regulator Assembly outlet fitting.
6. Unsolder the refrigerant capillary tube at the Drier.
7. Unsolder the Compressor discharge line, at the top of the Water-Cooled Condenser.
8. Unsolder the Condenser water outlet line, at the top of the Water-Cooled Condenser.
9. Remove two screws and washers and the Water-Cooled Condenser from the Cabinet.

B. To replace the Water-Cooled Condenser, reverse the removal procedures.

X. REMOVAL AND REPLACEMENT OF THE CUBE SIZE CONTROL

A. To remove the Cube Size Control:

1. Remove screws and the Front Panel to gain access to the Cube Size Control.
2. Trace capillary Tube, from the Cube Size Control, to the refrigerant suction line on

the Evaporator Platen Assembly; then peel back the insulation.

3. Remove clips and the coiled capillary tube bulb out of the Freezer section of the Cabinet.
4. Remove electrical leads from the Cube Size Control.
5. Remove screws and the Cube Size Control.

B. To replace the Cube Size Control, reverse the removal procedure.

XI. REMOVAL AND REPLACEMENT OF THE CURTAIN ASSEMBLY - TWO

A. To remove the Curtain Assembly:

1. Remove screws and the Right Side Panel to gain access to the Curtain Assembly to be removed.
2. Tilt the top of the plastic Cube Chute forward slightly, then, lift the Cube Chute up for removal.

NOTE

Before removing the Curtain Assembly in the next step, look inside the ice chute opening to note the irregular end of the plastic stiffener of the Curtain Assembly is installed at the left side of the opening.

3. Remove three U-Type Clips and the plastic Curtain Assembly from the top lip of the ice chute opening.

B. To replace the Curtain Assembly, reverse the removal procedure.

NOTE

Be sure to install the replacement Curtain Assembly with the irregular end of the plastic stiffener positioned at the left side of the ice chute opening; and, the edge of the Curtain is dressed evenly with the top lip of the ice chute opening and secured with three U-Type Clips. The thin, clear plastic sheet of the curtain should hang down evenly.

XII. REMOVAL AND REPLACEMENT OF THE DRIER

NOTE

Always install a replacement Drier, anytime the sealed refrigeration system is opened. Do not replace the Drier until all other repair or replacement has been completed.

A. To remove the Drier:

1. Remove screws and the Left Side Panel and the Front Panel.
2. Bleed off or blow the refrigerant charge through the Schrader valve.
3. Remove the Cable Tie attaching the Drier to the rear of the Control Box.

4. Unsolder refrigeration lines at both ends of the Drier.

B. To replace the Drier:

CAUTION

1. If the factory seal is broken on the replacement Drier, exposing it to the atmosphere more than a few minutes, the Drier will absorb moisture from the atmosphere and lose substantial ability for moisture removal.
2. Be sure the replacement Drier is installed with the arrow positioned in the direction of the refrigerant flow.

1. Remove the factory seals from the replacement Drier and install the Drier in the refrigerant lines with the arrow positioned in the direction of the refrigerant flow.
2. Solder the Drier into the lines, two places.
3. Secure Drier to Drain Bracket with a Cable Tie.
4. Purge the system and check for leaks.
5. Thoroughly evacuate the system to remove moisture and non-condensables.
6. Charge the system with refrigerant, by weight. SEE NAMEPLATE.
7. Replace and attach the Left Side Panel and the Front Panel.

XIII. REMOVAL AND REPLACEMENT OF THE FAN MOTOR ASSEMBLY - AIR-COOLED MODELS

A. To remove the Fan Motor Assembly:

1. Remove screws and the Left Side Panel and the Front Panel.
2. Disconnect the two electrical leads from the Fan Motor at the Control Box Assembly.
3. Remove screws and the Fan Motor Assembly; and remove the Fan Motor and Bracket from the Chassis base.
4. Loosen set screws on the Fan Blade and remove the Fan Blade from the Fan Motor.
5. Remove screws and lockwashers and separate the Fan Motor from the Fan Motor Bracket.

B. To replace the Fan Motor Assembly, reverse the removal procedure.

NOTE

Be sure to replace the Fan Blade with the hub of the Fan Blade facing the Fan Motor, to ensure air flow is toward the Fan Motor.

XIV. REMOVAL AND REPLACEMENT OF THE FREEZING CHAMBER - (TWO)

A. To remove the Freezing Chamber:

1. Remove screws and the Top Panel, Front Panel and the Right Side Panel to gain access to the Freezing Chamber.
2. Tilt the top of the plastic Cube Chute forward slightly, then, lift the Cube Chute up for removal.
3. Remove three U-type Clips and the plastic Curtain Assembly.
4. Reach through the ice chute opening in the upper Freezing Chamber and feel for the Spray Bar.
5. Move hand to the center hub and rotate the Spray Bar, so one end is aligned with the ice chute opening.
6. Lift the Spray Bar up, off of the jet bearing hub, then, remove the Spray Bar through the ice chute opening.
7. Disconnect electrical leads and ground wire from terminals on the Agitator Motor.
8. Reach through the same ice chute opening, as before, and grasp the top Drive Fork with one hand, and the Agitator Motor Fan on top of the Freezing Chamber, with the other hand.
9. Hold the Fan Blades still and rotate the left-hand thread Drive Fork to the right, COUNTERCLOCKWISE, and unscrew the Drive Fork from the Agitator Motor.
10. Remove four screws and lift out the Agitator Motor.
11. Insert and hold firm, a screwdriver through a hole in the top jet bearing, then, reach through the ice chute opening of the lower Freezing Chamber and rotate the left-hand thread Drive Fork to the right, COUNTERCLOCKWISE, to unscrew the bottom Drive Fork from the Water Tube.
12. Raise the screwdriver and top jet bearing up, an inch or so, to expose the hole in the Water Tube; next, insert and hold firm, a second screwdriver in the hole in the upper end of the Water Tube; then, rotate the screwdriver in the top jet bearing to the left, CLOCKWISE, to unscrew the bearing from the Water Tube.
13. Remove bearing, both screwdrivers and push the Water Tube UP, and remove the tube through the hole in the Platen and Cover Assembly.
14. Remove hose clamps and work loose four Tygon Tubes from the Freezing Chamber, three from the Water Pump and one drain tube.

15. Carefully lift the Platen and Cover Assembly, and tie off or use a board to support and give ample space to allow removal of the Freezing Chamber.

16. Remove screws and lockwashers and bolts and the upper Freezer Mount Plate; or the lower Freezer Mount Plate.

17. Carefully work the upper Freezing Chamber out of the Chassis; or, remove hose clamps and Tygon Tubes from the lower Freezing Chamber, and remove the lower Freezing Chamber.

B. To replace the Freezing Chamber, reverse the removal procedure.

XV. REMOVAL AND REPLACEMENT OF THE SPRAY BAR AND WATER TUBE ASSEMBLY

A. To remove the Spray and Water Tube Assembly.

1. Remove screws and the Right Side Panel to gain access to the Spray Bar Assemblies.

2. Tilt the top of the plastic Cube Chute forward slightly, then, lift the Cube Chute up for removal.

3. Remove three U-type Clips and the plastic Curtain Assembly.

4. Reach through the ice chute opening in the Freezing Chamber and feel for the Spray Bar.

5. Move hand to the center hub and rotate the Spray Bar, so one end is aligned with the ice chute opening.

6. Lift the Spray Bar up, off of the jet bearing hub, then, remove the Spray Bar through the ice chute opening.

7. Disconnect electrical leads and ground wire from terminals on the Agitator Motor.

8. Reach through the upper ice chute opening, and grasp the Top Fork with one hand, and the Agitator Motor Fan on top of the Freezing Chamber, with the other hand.

9. Hold the Fan Blades still and rotate the left-hand thread Drive Fork to the right, COUNTERCLOCKWISE, and unscrew the Drive Fork from the Agitator Motor.

10. Remove four screws and lift out the Agitator Motor.

11. Insert and hold firm, a screwdriver through a hole in the top bearing; then, reach through the ice chute opening of the lower Freezing Chamber and rotate the left-hand thread Drive Fork to the right, COUNTERCLOCKWISE, to unscrew and remove the bottom Drive Fork from the Water Tube. Remove the lower Spray Bar.

12. Raise the screwdriver and top jet bearing up, an inch or so, to expose the hole in the Water Tube; next insert and hold firm, a second screwdriver in the hole in the upper end of the Water Tube; then, rotate the Screwdriver in the top jet bearing to the left, **CLOCKWISE**, to unscrew the bearing from the Water Tube.
13. Remove bearing, both screwdrivers, and push the Water Tube UP, and remove the tube through the hole in the Platen and Cover Assembly.

B. To replace the Spray Bar and Water Tube Assembly, reverse the removal procedure.

XVI. REMOVAL AND REPLACEMENT OF THE WATER PUMP ASSEMBLY - (TWO)

A. To remove the Water Pump Assembly:

1. Remove screws and the Right Side Panel and the Front Panel.
2. Remove one screw and one end of the green ground wire from the Water Pump Bracket.
3. Remove two screws and washers attaching the Water Pump Assembly to the Water Pump Bracket.
4. Remove three hose clamps connecting the three Tygon Tubes to the Freezing Chamber; then, lift the Water Pump Assembly off of the Water Pump Bracket and work loose the three attached Tygon Tubes from the Freezing Chamber.

B. To replace the Water Pump Assembly, reverse the removal procedure.

XVII. REMOVAL AND REPLACEMENT OF THE WATER REGULATOR ASSEMBLY - WATER-COOLED MODELS

NOTE

A. To remove the Water Regulator Assembly:

1. Remove screws and the Left Side Panel and the Front Panel.
2. Check to be sure building source water inlet supply shutoff valve to rear of Chassis is OFF.
3. Bleed off or blow the refrigerant charge through the Schrader valve.
4. Disconnect water inlet supply line at the left bottom rear of the Chassis.
5. Disconnect water line at the inlet and outlet fittings on the Water Regulator Assembly.
6. Unsolder the Water Regulator Valve capillary tube from the Compressor refrigerant discharge line.
7. Remove two screws and the Water Regulator Assembly from the Chassis Base.

B. To replace the Water Regulator Assembly, reverse the removal procedure.

SECTION V

MAINTENANCE & CLEANING INSTRUCTIONS

I. GENERAL

The periods and procedures for maintenance and cleaning are given as guides and are not to be construed as absolute or invariable. Cleaning especially will vary, depending upon local water conditions and the ice volume produced; and, each icemaker must be maintained individually, in accordance with its own particular location requirements.

II. ICEMAKER

THE FOLLOWING MAINTENANCE SHOULD BE SCHEDULED AT LEAST TWO TIMES PER YEAR ON THIS ICEMAKER. CALL YOUR AUTHORIZED SCOTSMAN SERVICE AGENCY.

1. Check and clean water line Strainers.
2. Check that the Icemaker cabinet is level, in side-to-side and front-to-rear directions.
3. Clean the water system Evaporator, Freezing Chamber Reservoir and Spray Bars, using a solution of SCOTSMAN Ice Machine Cleaner. Refer to procedure V-III, CLEANING-Icemaker.

NOTE

Cleaning requirements vary according to local water conditions and individual user operation. Continuous check of the clarity of ice cubes and visual inspection of the Spray Bar parts before and after cleaning will indicate frequency and procedure to be followed in local areas.

4. Check that plastic curtains hang down evenly within the opening at the front of the Freezing Chambers.
5. Check and tighten all bolts.
6. Check and tighten all electrical connections.
7. Check Hot Gas Solenoid Valve for correct operation and high pressure controls for cut-in and cut-out pressures.
8. With Icemaker and Fan Motor OFF on Air-Cooled Models, clean Condenser, using vacuum cleaner, whisk broom or brush. Instruct customer to clean frequently.
9. Check that Fan Blades move freely, are not touching any surfaces and are not bent or out of balance.
10. Check for refrigerant leaks and tighten line connections.

11. Check for water leaks and tighten drain line connections. Pour water down Bin drain line to be sure that drain line is open and clear.
12. Check size, condition and texture of ice cubes. Perform adjustments as required. Refer to procedure IV-II.
13. Check Bin Thermostat Control bulb to test shutoff. With the Icemaker in the Harvest Cycle, place ice on the bulb, which should cause the Icemaker to shut OFF at the end of the Harvest Cycle.

NOTE

Within minutes after the ice is removed from the sensing bulb, the bulb will warm up and cause the Icemaker to restart. This control is factory set and should not be reset until testing is performed. Normal setting is about 35-degrees F. CUT-OUT and 40-degrees F. CUT-IN.

III. CLEANING - Icemaker

1. Remove screws and Front Panel and Top Panel.
2. Tilt the top of the plastic Cube Chute forward slightly, then, lift the Cube Chute up for removal.
3. Move the Master ON-OFF toggle switch and the Compressor ON-OFF toggle switch, on the Control Box, to the OFF positions.
4. Slowly rotate the shaft of the Timer & Switch Assembly, protruding through the hole in the front of the Control Box Cover, until you hear an audible click as the microswitch actuator arm drops into the cam slot, the START position of the Harvest Cycle, then stop. See Figure 5-1.
5. Remove both Defrost Water Tubes, located at the top, rear of each Freezing Chamber, from the tube hole.

WARNING

SCOTSMAN Ice Machine Cleaner contains Phosphoric and Hydroxyacetic acids. These compounds are corrosive and may cause burns if swallowed. DO NOT induce vomiting. Give large amounts of water or milk. Call physician immediately. In case of external contact, flush with water. KEEP OUT OF THE REACH OF CHILDREN.

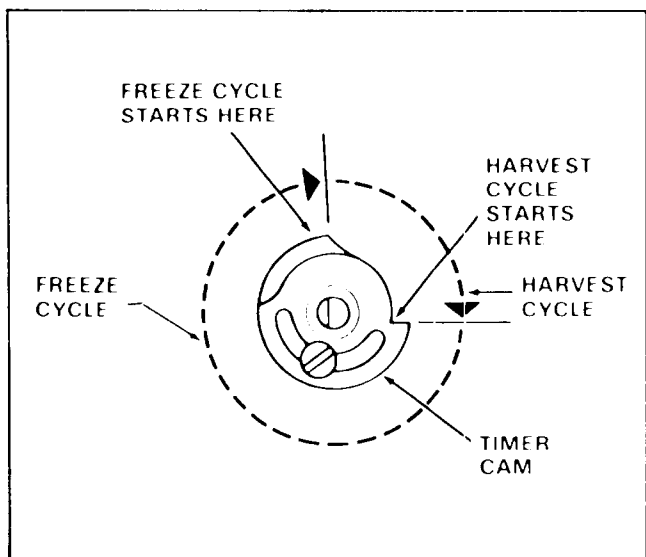

Figure 5-1. START Positions for the Freeze/Harvest Cycles.

7. For EACH Freezing Chamber, prepare the following cleaning solution: Mix 16-ounces of SCOTSMAN Ice Machine Cleaner with eleven pints of fresh, potable water in a clean container.
8. Pour each batch of prepared cleaning solution into the respective Freezing Chambers, through the Defrost Water Tube holes at the top, center rear of the Freezing Chambers.
9. Immediately replace the Defrost Water Tubes; then, move the Master ON-OFF Switch, on the Control Panel, to ON.
10. Allow the icemaking system to operate normally for twenty minutes into the Freezing Cycle.

NOTE

NO ICE CUBES will be made, because the Compressor has been switched OFF.

11. At the end of twenty minutes, rotate the shaft of the Timer & Switch Assembly, CLOCKWISE, to start a second Harvest Cycle. See Figure 5-1.

12. Allow the icemaking system to operate normally through the Harvest Cycle; then, when the Harvest Cycle is completed, rotate the Timer again THROUGH the Freezing Cycle to START another Harvest Cycle. Perform this Harvest Cycle operation three times.

NOTE

During each Harvest Cycle, fresh inlet water is introduced into the water system and acts to rinse all water-related parts and to wash away most mineral concentration through the drain.

13. Wash both Curtain Assemblies and the Cube Chute in a solution of one ounce of household bleach in one gallon of water.
14. Using a clean, damp cloth or disposable paper wiper, wipe off the Curtain Assemblies and the Cube Chute.
15. Move the Compressor ON-OFF toggle switch, on the Control Box, to the ON position.
16. Replace Curtain Assemblies and the Cube Chute.
17. Check each ice cube harvest, until the ice cubes are clear and the acid taste is eliminated.

CAUTION

DO NOT USE ice cubes produced from the cleaning solution. Be sure none remains in the Bin.

18. Pour hot water over ice cubes in the Bin, to melt the ice cubes and allow the same cleaning solution to be used to thoroughly wash the inner surfaces of the Bin and the solution to help clean the drain lines as it drains. Rinse inner surfaces of Bin.
19. Replace all panels removed.
20. Clean and sanitize the interior Bin surfaces each week.

SECTION VI SERVICE DIAGNOSIS

The Service Diagnosis Section is for use in aiding the serviceman in diagnosing a particular problem for pin-pointing the area in which the problem lies, thus an ever available reference for proper corrective action.

The following charts list corrective actions for the causes of known symptoms of certain problems that can occur in the Icemaking-Refrigeration System.

I. ICEMAKING - REFRIGERATION SYSTEM

SYMPTOM	POSSIBLE CAUSE	CORRECTION
Irregular size cubes and some cloudy.	Some jets plugged. Shortage of water. Unit not level. Water overflowing vent holes on low side, burning cubes.	Clean jets. See Shortage of water CORRECTION. Level cabinet, as required.
Cubes too large.	Cube Size Control set too cold.	Rotate Cube Size Control dial toward WARMER.
Cubes too small.	Cube Size Control set too warm. Partially restricted capillary tube. Moisture in system. Shortage of water. Loss of refrigerant.	Rotate Cube Size Control dial toward COLDER. Blow refrigerant charge; replace drier; evacuate system; add refrigerant charge. Same as above CORRECTION. See Shortage of water CORRECTION. Check for refrigerant leaks, correct leaks; recharge system.
Cloudy Cubes.	Shortage of water. Dirty water supply. Accumulated impurities.	See Shortage of water SYMPTOM. Install water filter or softener. Use SCOTSMAN Ice Machine Cleaner.
Shortage of water.	Water spraying out through curtain. Water solenoid not opening. Water leak in sump area. Partial restrictions in water strainer.	Hang curtain in proper position. Repair or replace solenoid. Locate leak and repair or correct condition. Clean or replace strainer.
Shortage of water in upper freezing chamber.	Defective lower seal in upper freezing chamber.	Replace lower seal.

SYMPTOM	POSSIBLE CAUSE	CORRECTION
Decreased ice capacity.	Defective compressor. Leaky water valve. High head pressure, result of dirty condenser or faulty Fan Motor. Non-condensable gas in the system. Poor circulation or extreme hot location. Overcharge of refrigerant. Hot gas solenoid valve leaking. Partially restricted capillary tube.	Replace compressor. Repair or replace valve. Clean condenser. Repair or replace Fan Motor. Purge the system. Relocate the cabinet; or provide ventilation by cutting openings. Slowly purge off to correct charge. Replace valve. See Cubes too small CORRECTION.
Poor harvests.	Too short defrost time. Restriction in water inlet line. Hot gas solenoid does not open. Plugged air vent holes in upper part of cube cups.	Check and adjust harvest cycle. Check Timer two-minute setting. Check strainer and flow check valve. DO NOT remove flow control washers. Binds or burned out. Replace. Clean out air vent holes.
Icemaker does not harvest.	Water pressure too low.	Check for 20 PSI flowing water.
Compressor cycles intermittently.	Low voltage. Dirty condenser. Air circulation blocked. Defective Fan Motor. Non-condensable gases in system.	Check for circuit overload. Check building supply voltage, if low, contact power company. Clean condenser with vacuum cleaner or brush. NO WIRE BRUSH. Locate cabinet with adequate air space for proper air flow. Replace Fan Motor. Purge the system.
Icemaker will not operate.	Blown fuse in line. Master switch in OFF position. Faulty Master switch. Timer contacts open.	Replace fuse and check for cause. Set switch to ON position. Replace switch. Replace Timer microswitch.
Hole washed inside ice cube.	Water over the top of cube cups during harvest cycle.	Check and re-level the HC700 cabinet.

SECTION VII

WIRING DIAGRMS

This Section is provided as an aid in understanding the electrical circuitry of the Modular Cuber:

WARNING

When conducting a continuity check of the Modular Cuber:

- 1. Disconnect the main power source.**
- 2. DO NOT use an incandescent lamp or jumper wire, conduct all tests with a volt-ohm-meter.**

The Wiring Diagrams in this Section are:

Figure 7-1. Wiring Diagram HC700
115/208/220/60/3 - Air Cooled.

Figure 7-2. Wiring Diagram HC700
115/208/220/60/3 - Water-Cooled.

Figure 7-3. Wiring Diagram HC700
115/208-230/60/1 - Air-Cooled

Figure 7-4. Wiring Diagram HC700
115/208-230/60/1 - Water-Cooled.

**THIS UNIT MUST
BE GROUNDED**

THIS UNIT SHOWN IN THE
TIMED PORTION
OF THE FREEZING CYCLE

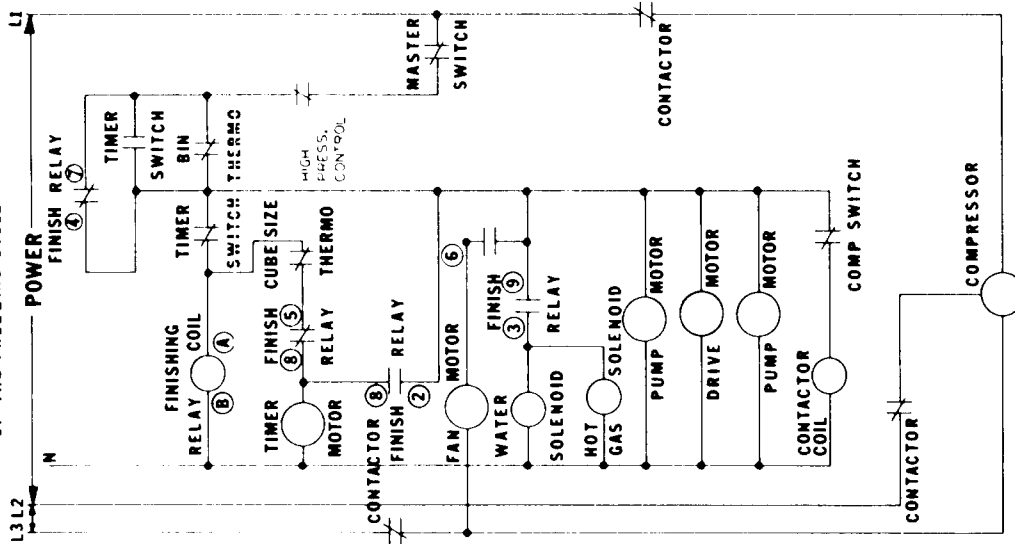

CAUTION: MORE THAN ONE DISCONNECT MEANS MAY BE
REQUIRED TO DISCONNECT ALL POWER TO THIS UNIT.

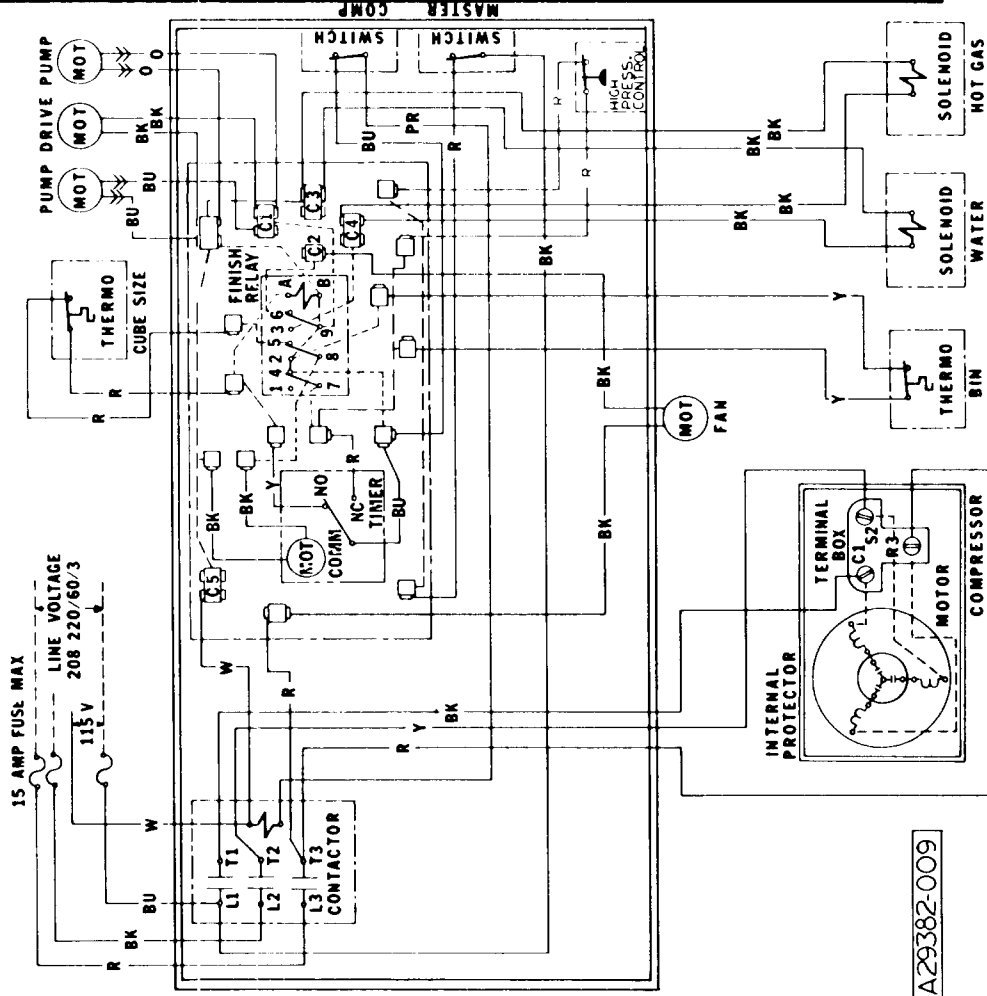

A29382-009

Figure 7-1. Wiring Diagram HC700 - Air-Cooled (115/208-220/60/3).

**THIS UNIT MUST
BE GROUNDED**

THIS UNIT SHOWN IN THE
TIMED PORTION
OF THE FREEZING CYCLE

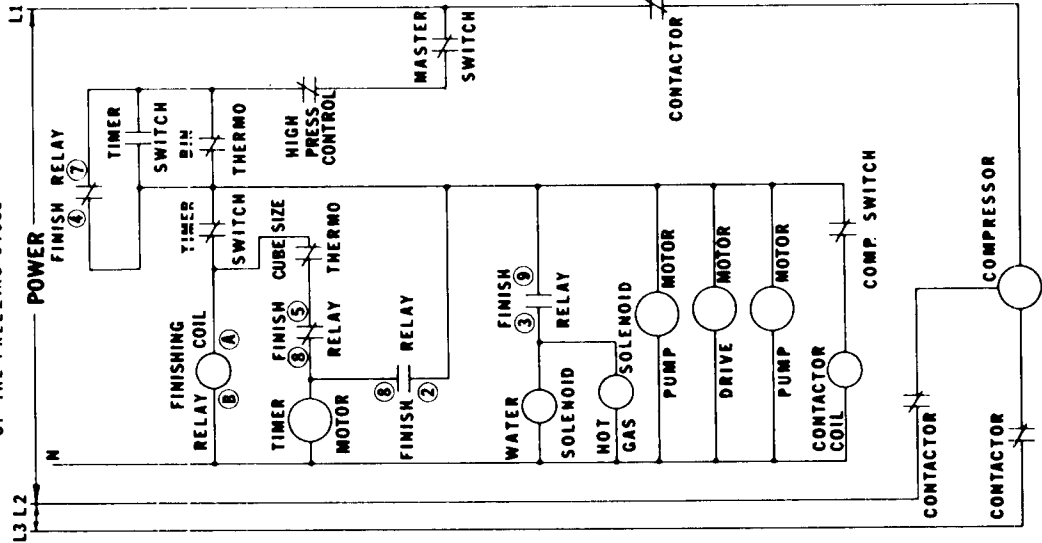

CAUTION: MORE THAN ONE DISCONNECT MEANS MAY BE
REQUIRED TO DISCONNECT ALL POWER TO THIS UNIT.

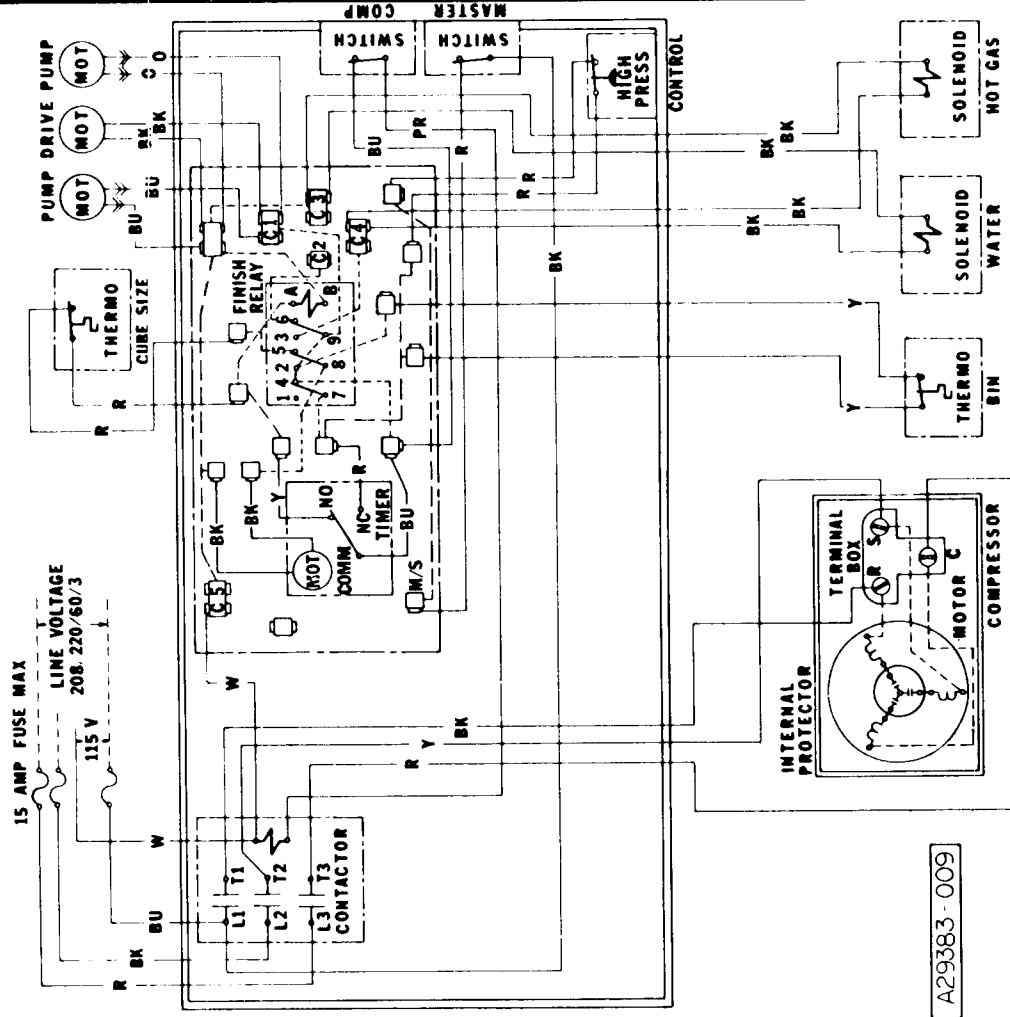
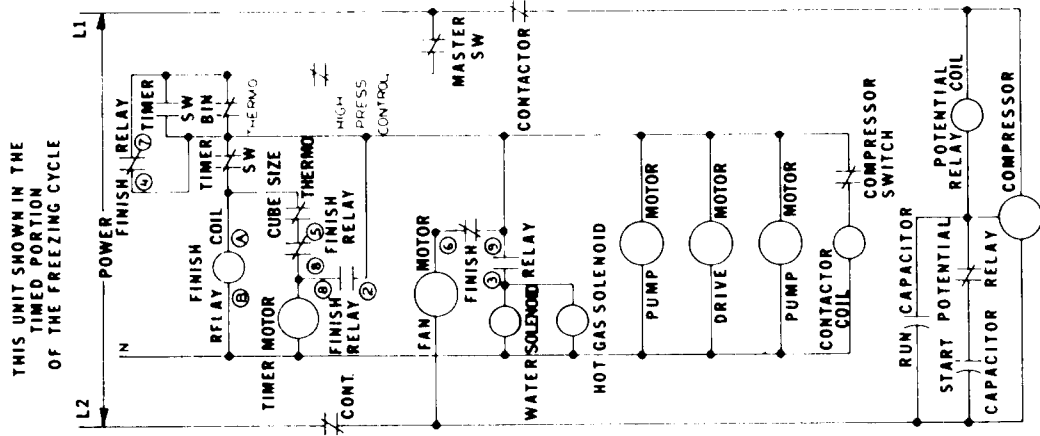

Figure 7-2. Wiring Diagram HC700 - Water-Cooled (115/208-220/60/3).

**THIS UNIT MUST
BE GROUNDED**



CAUTION: MORE THAN ONE DISCONNECT MEANS MAY BE
REQUIRED TO DISCONNECT ALL POWER TO THIS UNIT.

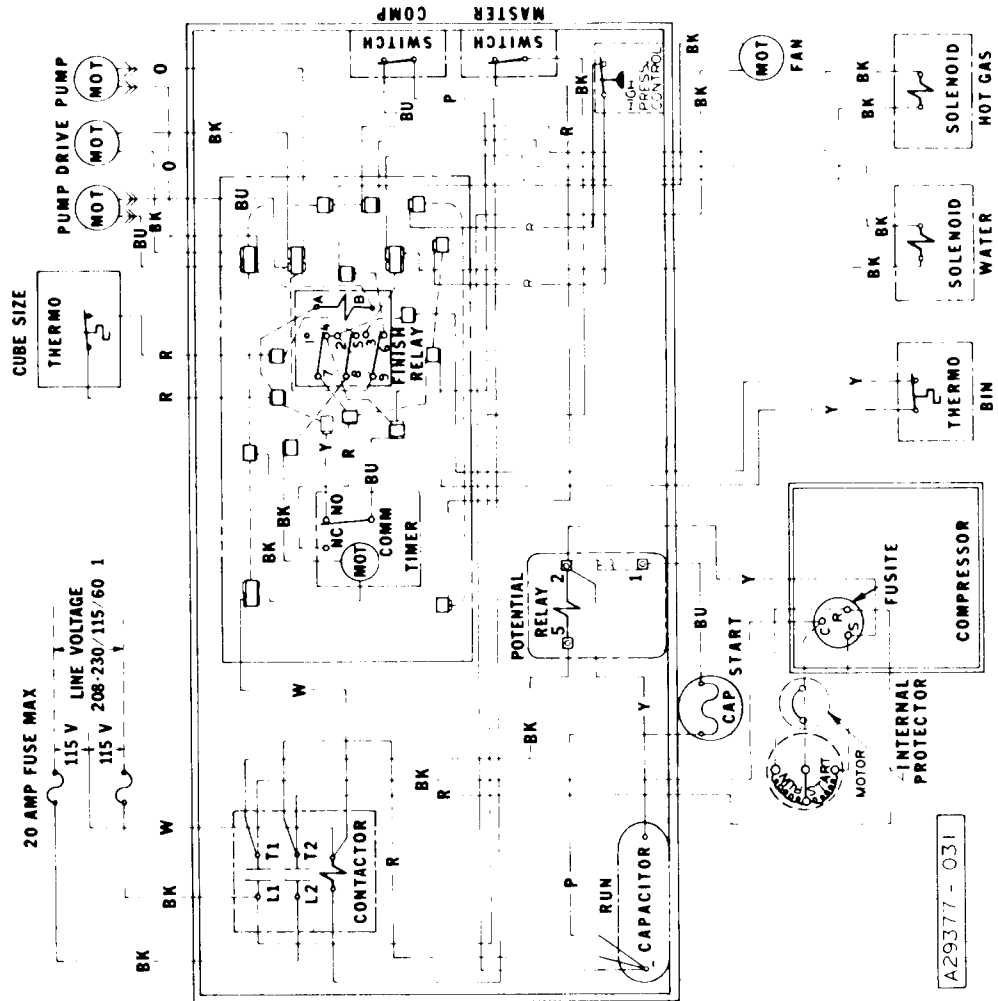
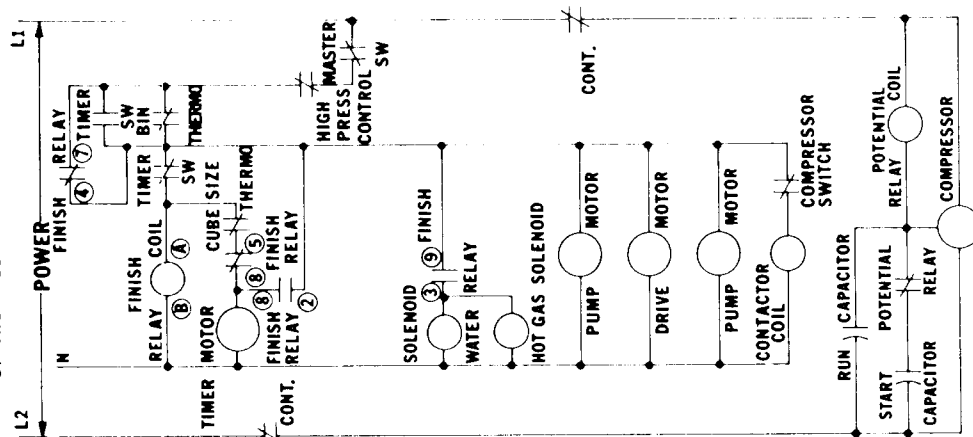

Figure 7-3. Wiring Diagram HC700 - Air-Cooled (115/208-230/60/1).

THIS UNIT MUST BE GROUNDED

THIS UNIT SHOWN IN THE TIMED PORTION OF THE FREEZING CYCLE



CAUTION: MORE THAN ONE DISCONNECT MEANS MAY BE REQUIRED TO DISCONNECT ALL POWER TO THIS UNIT.

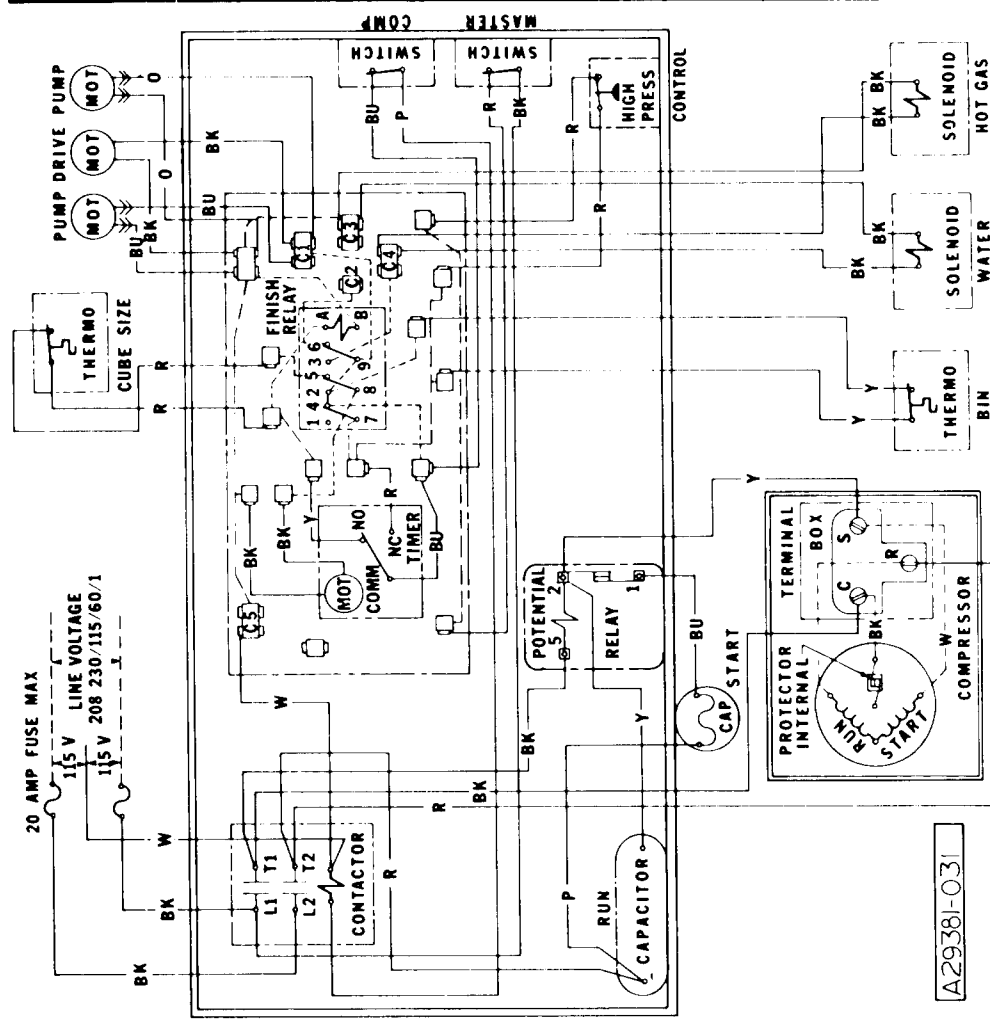

Figure 7-4. Wiring Diagram HC700 - Water-Cooled (115/208-230/60/1).

SECTION VIII

THE PARTS ILLUSTRATIONS AND PARTS LISTS

I. GENERAL

This section contains the Parts Illustrations and the Parts List for each of the major assemblies in the HC700 Modular Cuber.

Each Parts Illustration shows an assembly as an exploded view, with an Index Number for each part or sub-assembly, given in disassembly order. These Index Numbers key with the Parts List for the assembly and are found in the Parts List Column headed Index Number. The Description Column gives the identifying nomenclature for the item indexed. The Part Number Column gives the number of item. The Number Required Column gives the number of items required per assembly, but not necessarily the total number of parts required per Cuber.

All assemblies are cross-referenced both from the major assembly listing where they first appear in the Parts Listing to their break-down listing, and from the break-down listing, back to the major assembly (next higher assembly) listing.

A *No Number* designation, when used in the Part Number Column indicates the unit is not available from SCOTSMAN as an assembly. This designation is used only for the convenience and clarity of division in cataloging.

When an Index Number is followed by a letter (e.g. la, lb), the letter indicates the part listed is part of the assembly indexed by the basic Index Number. The number required of the part indexed by the number and letter combination is for only one of the assemblies indexed by

the basic Index Number and not necessarily the total number of parts used in the Cuber. Where the notation *Ref* occurs in the Number Required Column the number of the assemblies or parts required for use in the Cuber will be found under a previous Index Number or in the next higher assembly Parts Listing. The next higher listing Figure/Index number is shown in the Description Column immediately following the item's description.

II. HOW TO USE THE ILLUSTRATIONS AND PARTS LIST

To find the part number of a required part or assembly, turn to the List of Illustrations and find the page number of the Parts Illustration of the major or sub-assembly containing the part. Turn to the indicated page and locate the part and its Index Number on the specific illustration. Find the Index Number on the required part in the Parts List to determine the complete description of the part.

III. HOW TO ORDER PARTS OR ASSEMBLIES

When ordering parts or assemblies, to avoid costly delays and errors in shipment, give the part number, the complete description shown in the list, and the quantities of each part or assembly required. Also include the Model name, the serial number of the Cuber for which the part is required, and for parts which require color matching, the color of the Cabinet. See Figure 8-00, at the end of this Section for detailed ordering instructions.

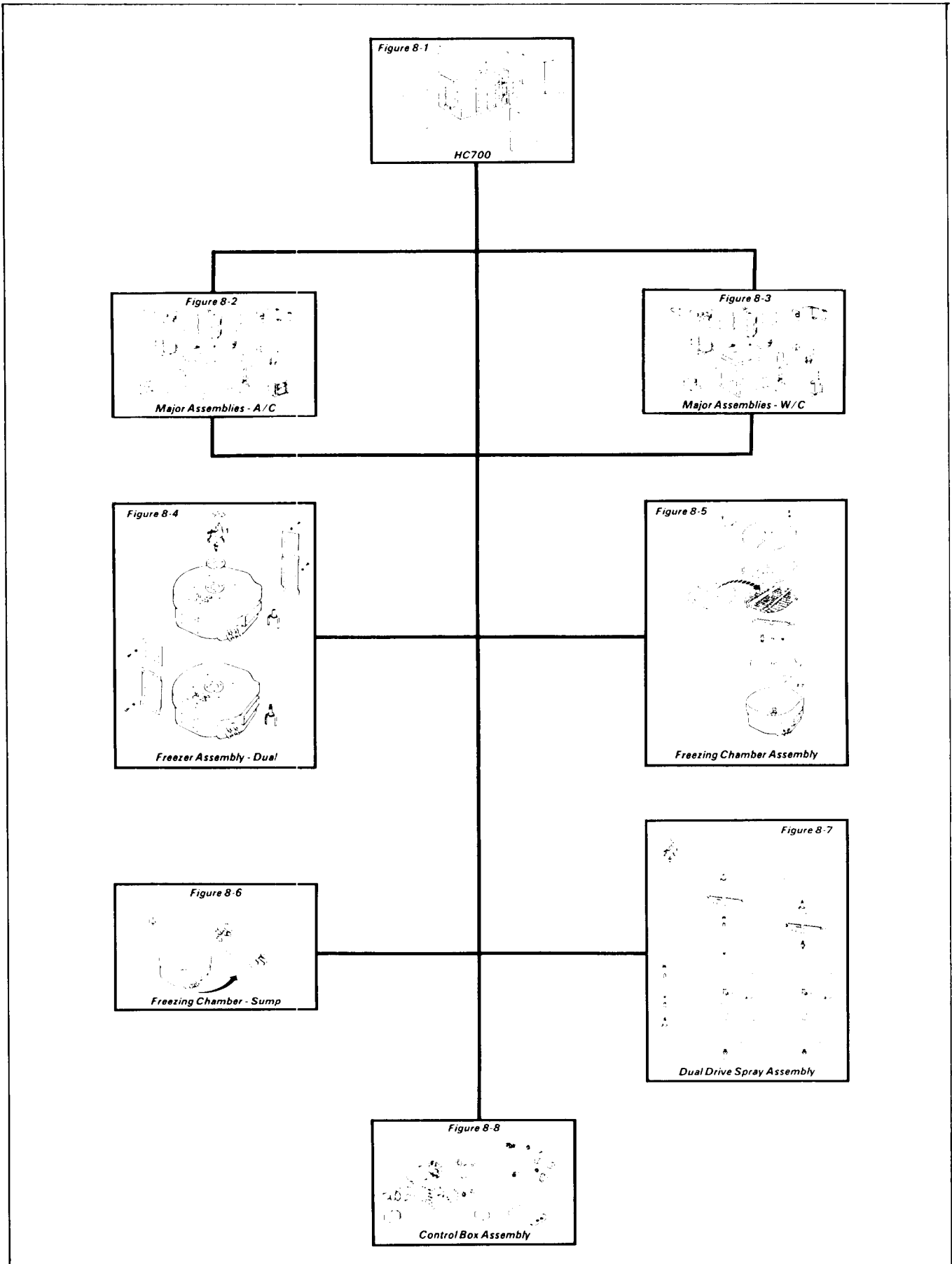

Figure 8-A. Model HC700 Modular Cuber Flow Chart

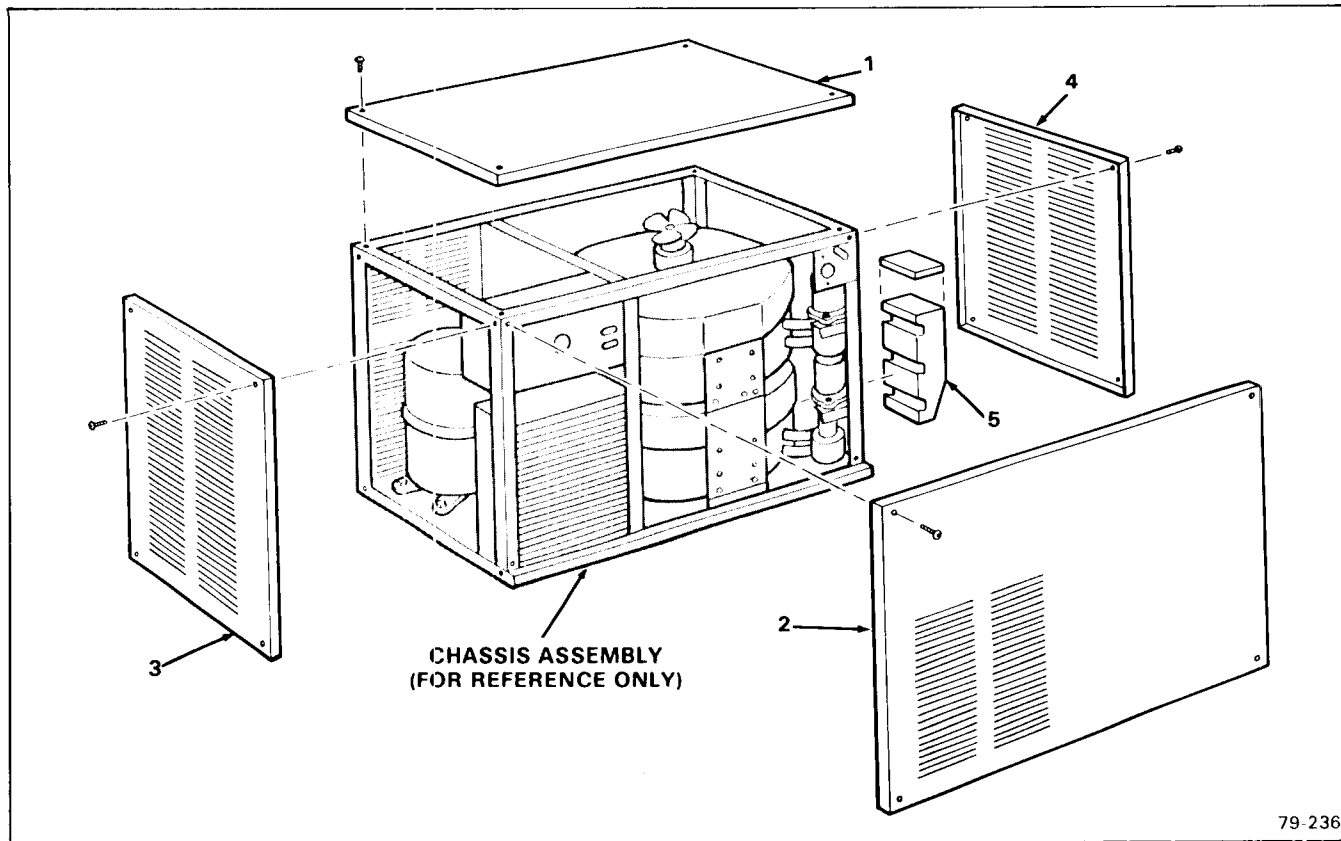

Figure 8-1. HC700 Modular Cuber.

INDEX NO.	DESCRIPTION	PART NUMBER	REQ'D NUMBER
	HC700 Modular Cuber * * *	No Number	Ref.
1	Panel, Top - (Enamel) Panel, Top - (Stainless Steel) attaching part, Index 1 Lockwasher, No. 8 Countersunk External Tooth Screw, No. 8 x 1-1/2 S/T Flat Hd * * *	A23784-005 A23784-002 03-1417-15 03-1419-09	1 1 2 4
2	Panel, Front - (Enamel) Panel, Front - (Stainless Steel) attaching part, Index 2 Lockwasher, No. 8 Countersunk External Tooth Screw, No. 8 x 1-1/4 S/T Flat Hd (SS) * * *	A26183-003 A26183-002 03-1417-15 03-1419-09	1 1 2 2
3	Panel, Left Side - (Enamel) Panel, Left Side - (Stainless Steel) attaching part, Index 3	A23899-004 A23899-002	1 1

Figure 8-1. HC700 Modular Cuber (Con't)

INDEX NO.	DESCRIPTION	PART NUMBER	REQ'D. NUMBER
	Screw, No. 8 x 1/2 T/F Tap (Stainless Steel) * * *	03-1404-10	2
4	Panel, Right Side - (Enamel) Panel, Right Side - (Stainless Steel) attaching part, Index 4	A23900-004	1
		A23900-002	1
	Screw, No. 8 x 1/2 T/F Tap (Stainless Steel) * * *	03-1404-10	2
5	Chute, Cube - w/Cover * * *	A27822-001	1

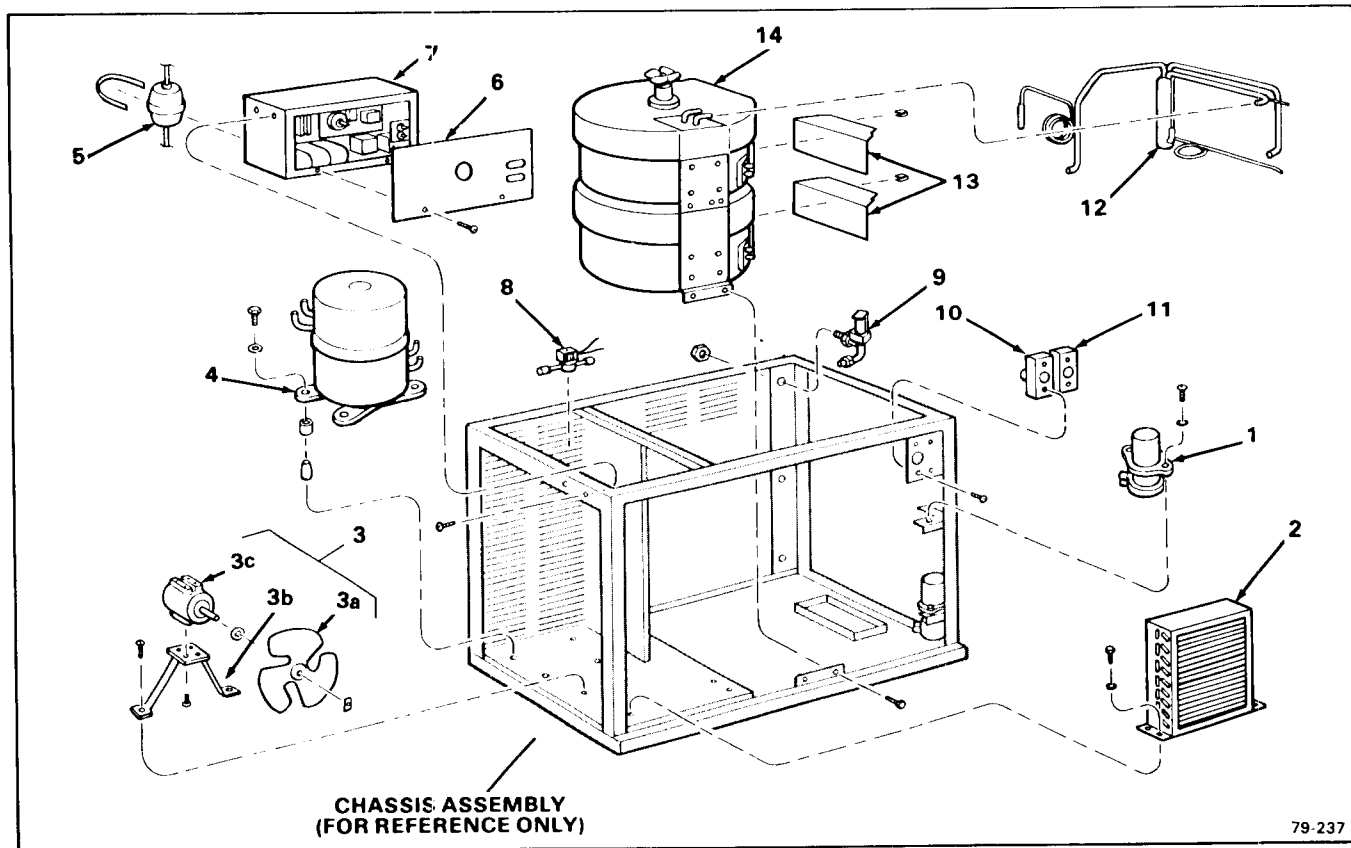

Figure 8-2. Major Assemblies - Air-Cooled

INDEX NO.	DESCRIPTION	PART NUMBER	REQ'D NUMBER
	Major Assemblies - Air-Cooled * * *	No Number	Ref.
1	Pump Assembly, Water attaching parts, Index 1 Holder, Drain Tube Clamp, Worm Drive Washer, No. 1/4 Plain Screw, No. 1/4-20 x 1/2 T/C Hex Hd * * *	12-1930-01 No Number 02-0706-00 03-1407-05 03-0571-01	1(2) 1(2) 1(2) 1(2) 1(2)
2	Condenser - Air-Cooled attaching parts, Index 2 Washer, No. 1/4 Plain Screw, No. 1/4-20 x 1/4 T/C Hex Hd * * *	18-0398-01 03-1407-05 03-0571-00	1 2 2
3	Fan Motor & Mounting Bracket Assembly	No Number	1
3a	Blade, Fan w/Mtg. Hdwre	18-0787-01	1
3b	Mount, Fan Mount	18-0597-00	1

Figure 8-2. Major Assemblies - Air-Cooled (Cont'd.)

INDEX NO.	DESCRIPTION	PART NUMBER	REQ'D NUMBER
3c	Motor, Fan - 115/208-220/60/3	18-3704-07	1
	Motor, Fan - 115/208-230/60/1	18-3704-02	1
	attaching parts, Index 3		
	Lockwasher, No. 8 External Tooth	03-1417-03	4
	Screw, No. 8-32 x 1-1/4 Phil Recess Pan Hd	No Number	4

4	Compressor - 115/208-220/60/3	18-3850-03	1
	Compressor - 115/208-230/60/1	18-3850-02	1
	attaching parts, Index 4		
	Grommet	18-2300-27	4
	Sleeve, Mounting	18-2300-26	4
	Washer, No. 5/16 Plain	03-1407-07	4
	Screw, No. 5/16-18 x 1-1/2 Hex Cap	03-1405-20	4

5	Drier	02-2426-02	1
	attaching part, Index 5		
	Tie, Cable	No Number	1

6	Cover, Control Box	No Number	1
	attaching part, Index 6 to 7		
	Screw, No. 6 x 1/4 T/F Tap (Stainless Steel)	03-1404-04	2

7	Control Box Assembly	No Number	1
	(See Figure 8-8)		
	attaching part, Index 7		
	Lockwasher, No. 8 Countersunk External Tooth	03-1417-15	2
	Screw, No. 8 x 1-1/4 S/T Flat Hd (Stainless Steel)	03-1419-09	2
	(used to attach LEFT end)		
	Screw, No. 8 x 3/8 T/F Tap	03-1404-08	2
(used to attach RIGHT end)			

8	Valve, Solenoid - Hot Gas	12-2135-01	1

9	Inlet Assembly, Water	12-1434-01	1

10	Control, Cube Size	11-0345-02	1

Figure 8-2. Major Assemblies - Air-Cooled (Cont'd.)

INDEX NO.	DESCRIPTION	PART NUMBER	REQ'D NUMBER
11	Control, Bin Level	11-0353-03	1
	attaching parts, Index 10 & 11		
	Screw, No. 8-32 x 3/16 Phil Recess Pan Hd	03-1403-14	2(4)
	* * *		
12	Exchanger Assembly, Heat	A29378-020	1
	* * *		
13	Curtain Assembly	02-2038-01	2
	attaching part, Index 13		
	Clip, U-Type	03-1526-01	3(6)
	* * *		
14	Freezer Assembly - Dual	No Number	1
	(See Figure 8-4)		
	attaching parts, Index 14		
	Screw, No. 1/4-20 x 1/2 T/C Hex Hd	02-0571-00	4
	* * *		

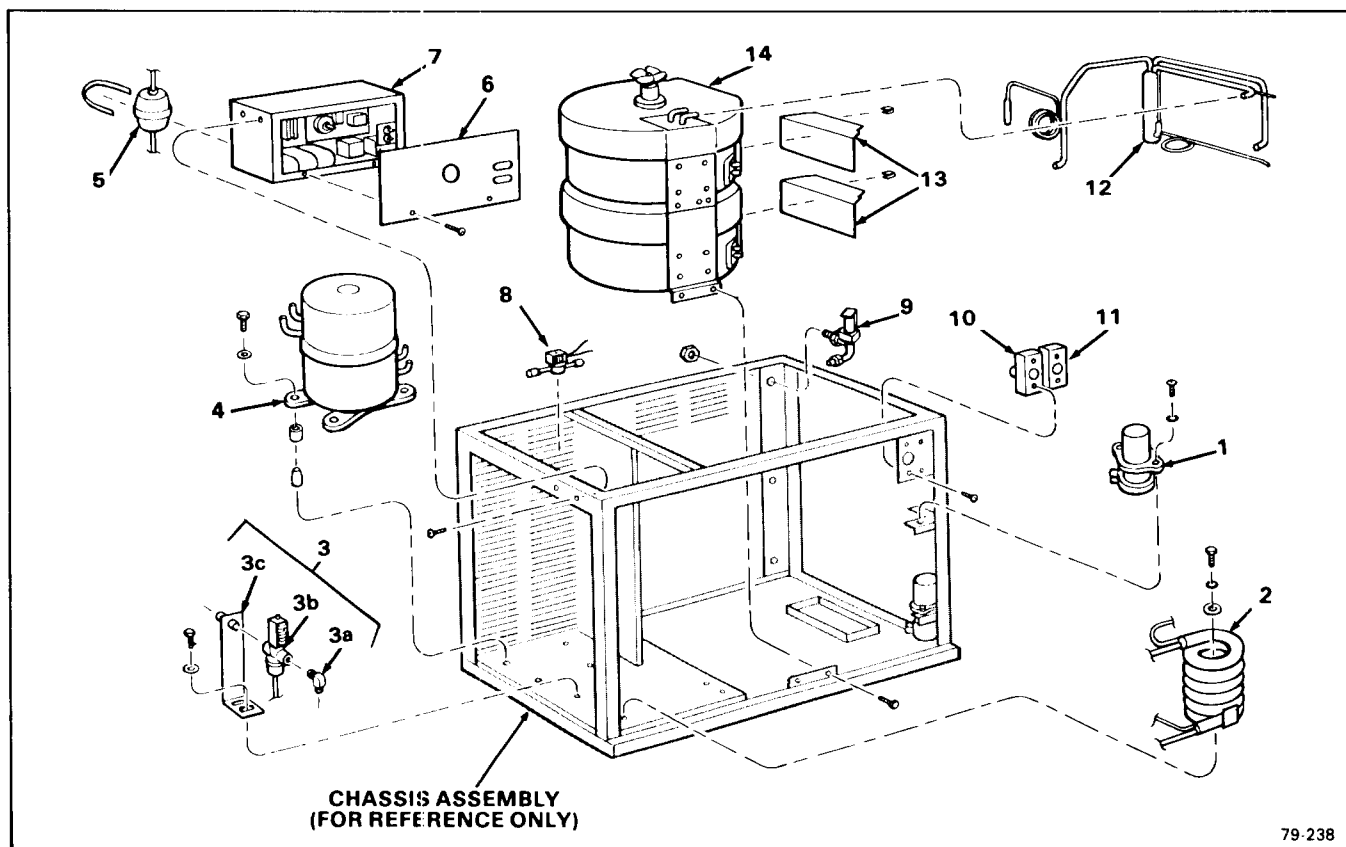

Figure 8-3. Major Assemblies - Water-Cooled

INDEX NO.	DESCRIPTION	PART NUMBER	REQ'D NUMBER
	Major Assemblies - Water-Cooled * * *	No Number	Ref.
1	Pump Assembly, Water attaching parts, Index 1 Holder, Drain Tube Clamp, Worm Drive Washer, No. 1/4 Plain Screw, No. 1/4-20 x 1/2 T/C Hex Hd * * *	12-1930-01 No Number 02-0706-00 03-1407-05 03-1571-01	1(2) 1(2) 1(2) 1(2) 1(2)
2	Condenser - Water-Cooled attaching parts, Index 2 Washer, No. 1/4 Plain Screw, No. 1/4-20 x 1/4 T/C Hex Hd * * *	18-3306-02 03-1407-05 03-0571-00	1 2 2
3	Regulator Assembly, Water - Condenser attaching parts, Index 3 Washer, No. 1/4 Plain Screw, No. 1/4-20 x 1/4 T/C Hex Hd	No Number 03-1407-05 03-0571-00	1 2 2

Figure 8-3. Major Assemblies - Water-Cooled (Cont'd.)

INDEX NO.	DESCRIPTION	PART NUMBER	REQ'D NUMBER
3a	Elbow, 3/8 NPT x 3/8 Flare Brass	16-0401-00	1
3b	Valve, Water Regulator	11-0198-02	1
3c	Bracket, Mounting - w/nipple * * *	A15924-000	1
4	Compressor - 115/208-220/60/3	18-3850-03	1
	Compressor - 115/208-230/60/1	18-3850-02	1
	attaching parts, Index 4		
	Grommet	18-2300-27	4
	Sleeve, Mounting	18-2300-26	4
	Washer, No. 5/16 Plain	03-1407-07	4
	Screw, No. 5/16-18 x 1-1/2 Hex Cap * * *	03-1405-20	4
5	Drier	02-2426-02	1
	attaching part, Index 5		
	Tie, Cable * * *	No Number	1
6	Cover, Control Box	No Number	1
	attaching part, Index 6 to 7		
	Screw, No. 6 x 1/4 T/F Tap (Stainless Steel) * * *	03-1404-04	2
7	Control Box Assembly (See Figure 8-8)	No Number	1
	attaching part, Index 7		
	Lockwasher, No 8 Countersunk External Tooth	03-1417-15	2
	Screw, No. 8 x 1-1/4 S/T Flat Hd (Stainless Steel) (used to attach LEFT end)	03-1419-09	2
	Screw, No. 8 x 3/8 T/F Tap (used to attach RIGHT end) * * *	03-1404-08	2
8	Valve, Solenoid - Hot Gas * * *	12-2135-01	1
9	Inlet Assembly, Water * * *	12-1434-01	1
10	Control, Cube Size	11-0345-02	1
11	Control, Bin Level	11-0353-03	1
	attaching parts, Index 10 & 11		
	Screw, No. 8-32 x 3/16 Phil Recess Pan Hd * * *	03-1403-14	2(4)

Figure 8-3. Major Assemblies - Water-Cooled (Cont'd.)

INDEX NO.	DESCRIPTION	PART NUMBER	REQ'D NUMBER
12	Exchanger Assembly, Heat * * *	A29378-020	1
13	Curtain Assembly attaching part, Index 13 Clip, U-Type * * *	02-2038-01 03-1526-01	2 3(6)
14	Freezer Assembly - Dual (See Figure 8-4) attaching parts, Index 14 Screw, No. 1/4-20 x 1/2 T/C Hex Hd * * *	No Number 02-0571-00	1 4

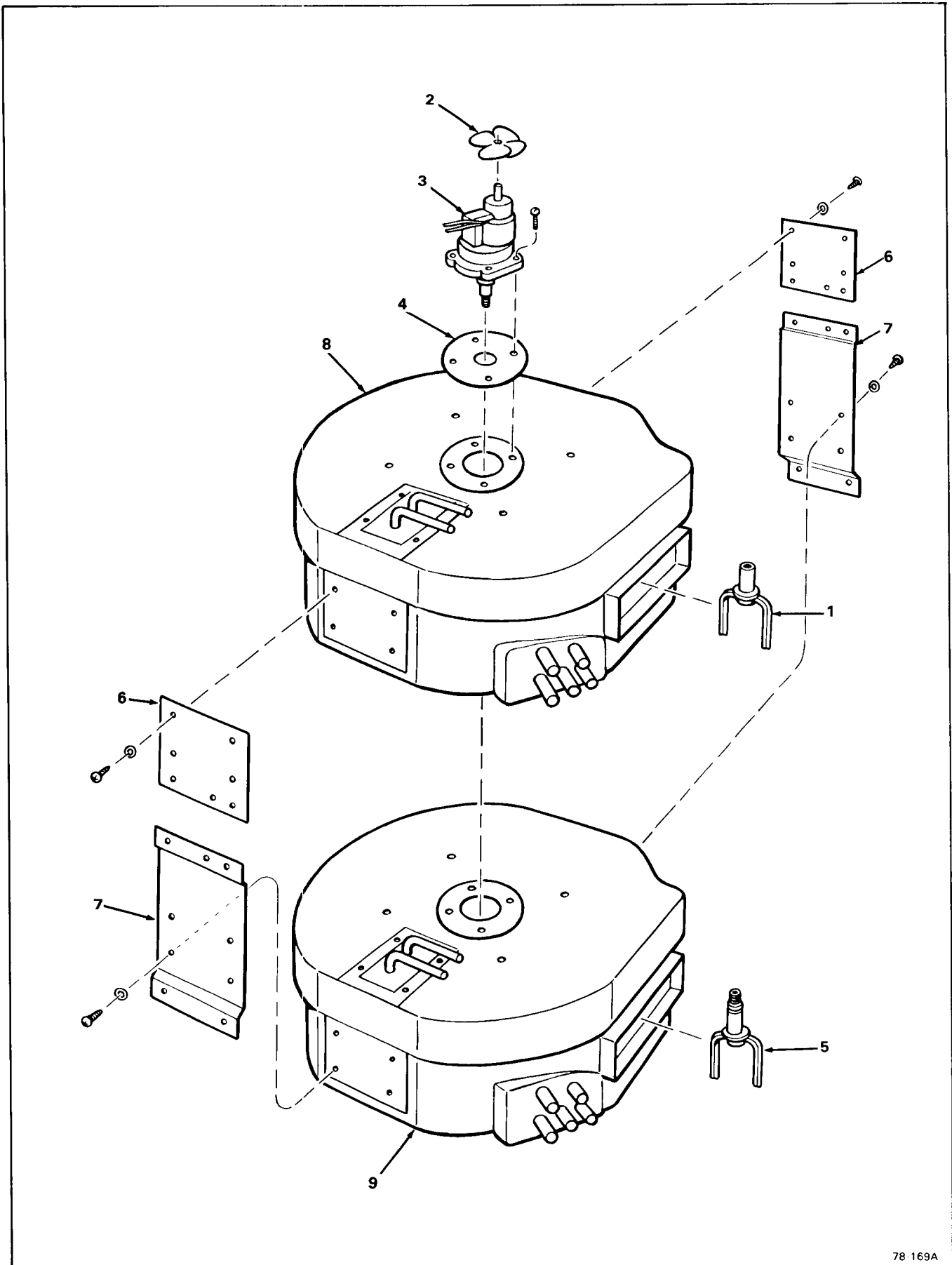

78 169A

Figure 8-4. Freezer Assembly - Dual

Figure 8-4. Freezer Assembly - Dual

INDEX NO.	DESCRIPTION	PART NUMBER	REQ'D NUMBER
	Freezer Assembly - Dual (See Figure/Index 8-2/14 and 8-3/14 for next higher Assembly) * * *	No Number	Ref.
1	Fork, Drive - Upper (left-hand thread) * * *	02-2369-02	1
2	Blade, Fan - Drivemotor * * *	12-0675-25	1
3	Drivemotor Assembly, Agitator	A24656-001	1
4	Gasket - Agitator Drivemotor Assembly attaching parts, Index 3 & 4	13-0176-00	1
	Screw, No. 6 x 1 T/F Tap * * *	03-1404-28	4
5	Fork, Drive - Lower (left-hand thread) * * *	02-2369-01	1
6	Plate, Mount Upper	A24502-001	1
7	Plate, Mount - Lower attaching parts, Index 6 & 7	A24500-001	1
	Lockwasher, No. 10 External Tooth	03-1417-05	2
	Screw, No. 10 x 5/8 T/F Tap (used in two upper holes in Index 6)	03-1404-18	2
	Lockwasher, No. 10 External Tooth	03-1417-05	2
	Screw, No. 10-16 x 1/2 S/T (used in middle holes in Index 6)	03-1360-00	2
	Screw, No. 1/4-20 x 1/2 T/C Hex Hd (used to attach Index 6 to 7)	03-0571-00	3
	Lockwasher, No. 10 External Tooth	03-1417-05	2
	Screw, No. 10 x 5/8 T/F Tap (used in middle two holes in Index 7)	03-1404-18	2
	Lockwasher, No. 10 External Tooth	03-1417-05	2
	Screw, No. 10-16 x 1/2 S/T (used in lower two holes in Index 7) * * *	03-1360-00	2
8	Chamber, Freezing - Upper	No Number	1
9	Chamber, Freezing - Lower (See Figure 8-5) * * *	No Number	1

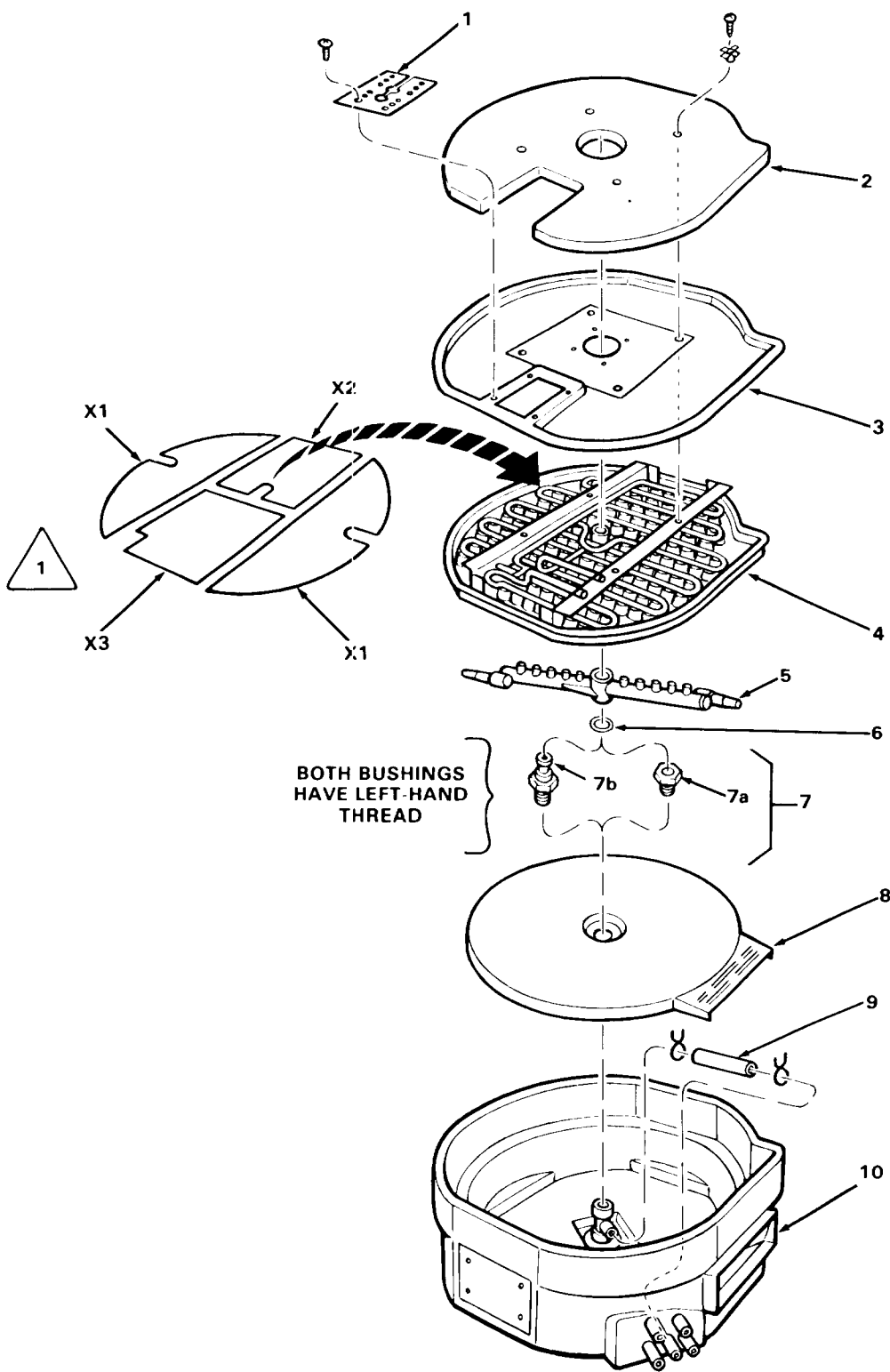

1

The above shown X-parts are ONLY used on Cup Platen Assembly P/N A27218-002, for SMALL size ice cube cups.

78-170

Figure 8-5. Freezing Chamber Assembly.

Figure 8-5. Freezing Chamber Assembly

INDEX NO.	DESCRIPTION	PART NUMBER	REQ'D NUMBER
	Freezing Chamber Assembly (See Figure 8-4/8 & 9 for next higher Assembly) ***	A24819-001	Ref.
1	Spacer, Tube attaching part, Index 1 Plug, Hole ***	02-2129-01	1(2)
		02-2065-02	4(8)
2	Cover, Insulation	02-2124-01	1(2)
3	Cover, Freezing Chamber	02-2123-01	1(2)
4	Platen Assembly, Cup (SMALL ice cube cups)	A27218-002	2(4)
	Platen Assembly, Cup (MEDIUM ice cube cups)	A27217-002	2(4)
	Platen Assembly, Cup (LARGE ice cube cups)	A27129-002	2(4)
	attaching parts, Index 2, 3, 4 Washer, Centering	A24830-001	4(8)
	Screw, No. 8 x 1/2 T/F Tap ***	03-1404-10	4(8)
5	Bar Assembly, Spray ***	A25480-001	2(4)
6	O-Ring ***	13-0617-25	2(4)
7	Bushing/Bearing (Left-hand threads)	No Number	1(2)
7a	Bushing, Nut (Used in UPPER Chamber)	A27197-001	1(2)
7b	Bearing, Spray Bar (Used in LOWER Chamber) (Also order P/N 13-0168-00 Water Seal with Index 7a or 7b) ***	02-2120-01	1(2)
8	Bottom, Inner ***	02-2028-01	1(2)

Figure 8-5. Freezing Chamber Assembly (Cont'd.)

INDEX NO.	DESCRIPTION	PART NUMBER	REQ'D NUMBER
9	Tube, Tygon (8-inch lg.) (Order by the foot) attaching part, Index 9 Clamp, Hose ***	13-0674-07	1(2)
10	Sump, Freezing Chamber (See Figure 8-6) *** NOTE: Spray Deflectors below, are ONLY used on SMALL ice cube Cup Platen Assembly P/N A27218-002.	No Number	1(2)
X1	Deflector, Spray (Installed at rounded ends, over top of cup molds)	A24198-001	2(4)
X2	Deflector, Spray (Installed around hole in Platen, with notch as shown)	A24198-003	1(2)
X3	Deflector, Spray (Installed LAST, under two tubes and over ends of X2) ***	A24198-004	1(2)

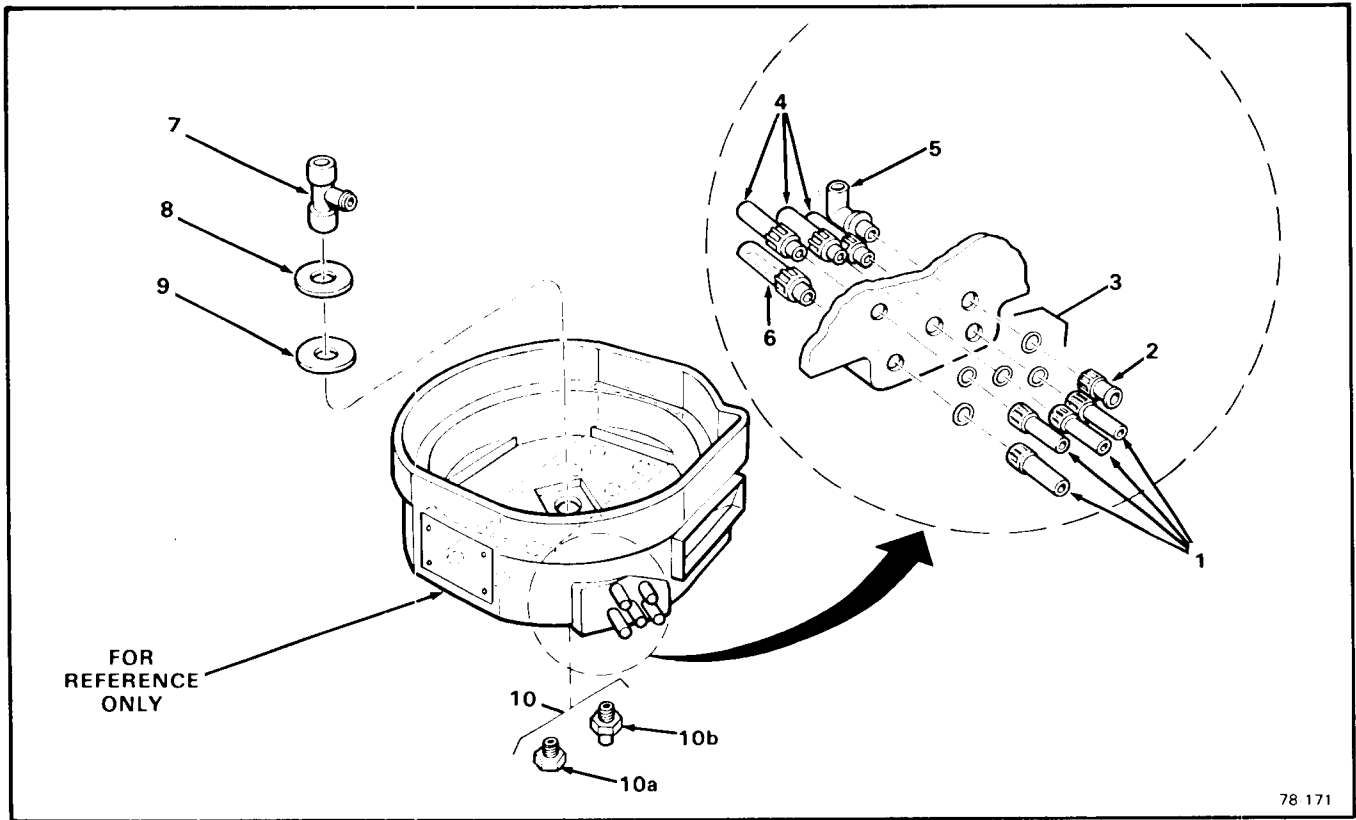

Figure 8-6. Freezing Chamber - Sump w/Tubes

INDEX NO.	DESCRIPTION	PART NUMBER	REQ'D NUMBER
	Freezing Chamber - Sump w/Tubes (See Figure 8-4/7 and 8) for next higher Assembly) *** NOTE: P/N A24819-001 shipped as replacement for both upper and lower Freezing Chamber, with Index 10a installed. For upper Freezing Chamber, also order Index 10b P/N A27197-002 and P/N 13-0168-00 Water Seal. Remove Index 10a and replace with Index 10b. ***	A24819-001	Ref.
1	Tube, Female ***	02-2081-01	4
2	Tube, Female - (Cut off) ***	A24379-001	1
3	O-Ring ***	13-0617-02	5

Figure 8-6. Freezing Chamber - Sump w/Tubes (Cont'd.)

INDEX NO.	DESCRIPTION	PART NUMBER	REQ'D NUMBER
4	Tube, Male ***	02-2080-01	3
5	Pipe, Stand ***	02-2125-01	1
6	Tube, Pick-Up - Pump ***	02-2082-01	1
7	Housing, Inlet ***	02-2121-01	1
8	Plate, Support - Spray Bar ***	A23827-001	1
9	Washer, Non-Metallic - 7/8-inch I.D. ***	03-1409-11	1
10	Plug, Bottom	No Number	1
10a	Plug, Bottom (Used in Lower Freezing Chamber)	02-2122-01	Ref.
10b	Plug, Bottom (Used in Upper Freezing Chamber) ***	A27197-002	Ref.

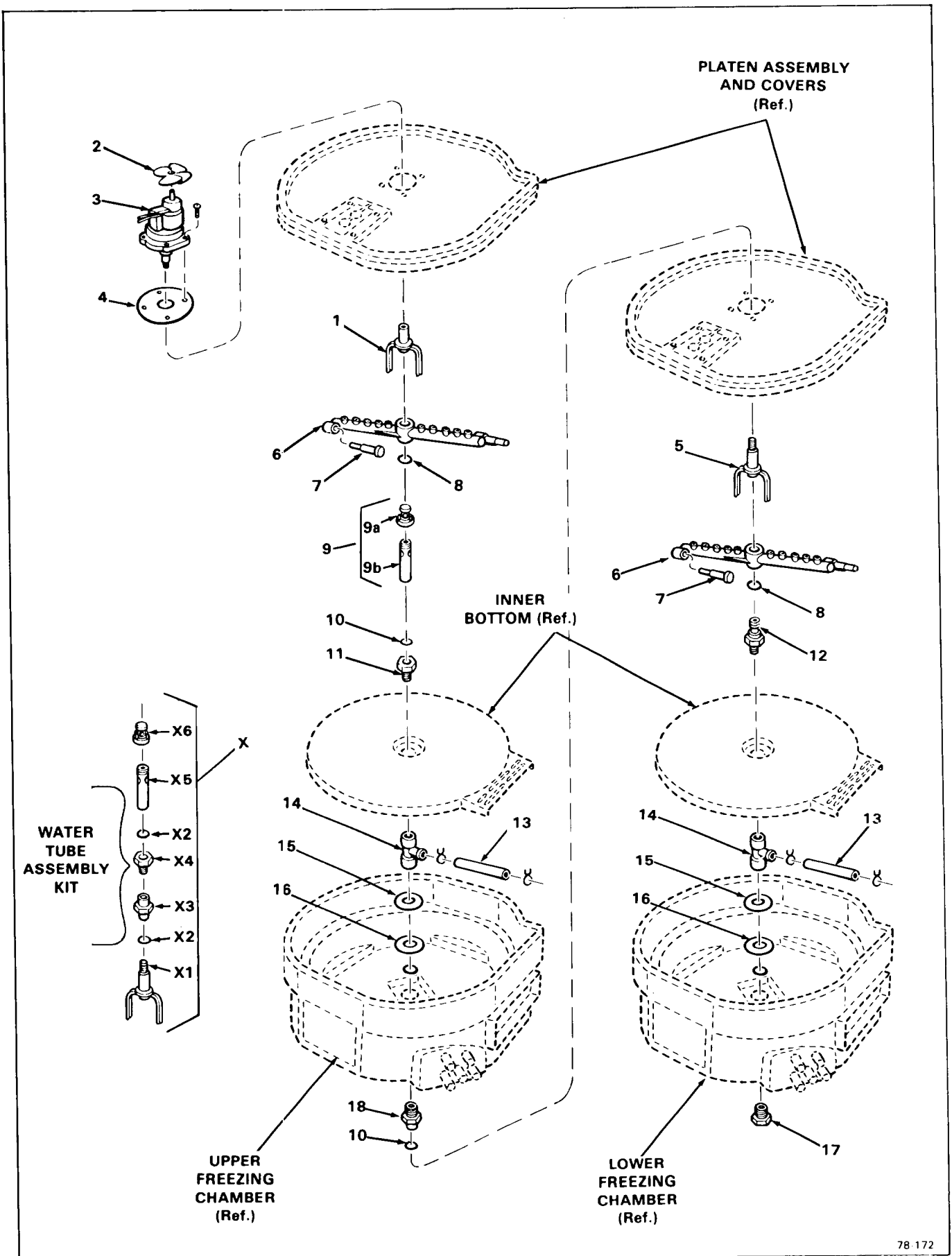

Figure 8-7. Dual Drive Spray Assemblies.

Figure 8-7. Dual Drive Spray Assemblies.

INDEX NO.	DESCRIPTION	PART NUMBER	REQ'D NUMBER
	Dual Drive Spray Assemblies (See Figures 8-4, 8-5, 8-6 for next higher Assembly) * * *	No Number	2
1	Fork, Drive - Upper (Left-hand thread) * * *	02-2369-02	Ref.
2	Blade, Fan - Drivemotor * * *	12-0675-25	Ref.
3	Drivemotor Assembly, Agitator	A24656-001	Ref.
4	Gasket - Agitator Drivemotor Assembly attaching parts, Index 3 & 4	13-0176-00	Ref.
	Screw, No. 6 x 1 T/F Tap * * *	03-1404-28	Ref.
5	Fork, Drive - Lower (Left-hand thread) * * *	02-2369-01	Ref.
6	Bar Assembly, Spray (w/rubber tips) * * *	A25480-001	1(2)
7	Rubber - Spray Bar * * *	13-0653-00	2(4)
8	O-Ring * * *	13-0617-25	2
9	Tube Assembly, Water	No Number	1
9a	Support, Spray Bar	02-2271-01	1
9b	Tube, Water (Available only in Index X, Water Tube Assembly, Kit P/N A24518-001. Obsolete, order Index X.	No Number	1
10	Seal, Water * * *	13-0168-00	2
11	Bushing, Nut (Also order Index 10, Water Seal) * * *	A27197-001	1
12	Bearing, Spray Bar * * *	02-2120-01	1
13	Tube, Tygon (8-inch lg.) (Order by the foot) attaching parts, Index 13	13-0675-07	1(2)
	Clamp, Hose * * *	02-1358-01	2(4)
14	Housing, Inlet * * *	02-2121-02	2

Figure 8-7. Dual Drive Spray Assemblies (Cont'd.)

INDEX NO.	DESCRIPTION	PART NUMBER	REQ'D NUMBER
15	Plate, Support - Spray Bar * * *	A23827-001	2
16	Washer, Non-Metallic - (7/8-inch I.D.) * * *	03-1409-11	2
17	Plug, Bottom (Used on Lower Freezing Chamber) * * *	02-2122-01	1
18	Bushing, Nut (Also order Index 10, Water Seal) (Used in Upper Freezing Chamber) * * *	A27197-002	1
X	Kit-Water Tube Assembly	A24518-001	1
X1	Fork, Drive (Left-hand thread)	02-2369-01	1
X2	Seal, Water	13-0168-00	2
X3	Bushing, Nut (Left-hand thread)	A27197-002	1
X4	Bushing, Nut (Left-hand thread)	A27197-001	1
X5	Tube, Water (Order Kit P/N 24518-001)	No Number	1
X6	Support, Spray Bar * * *	02-2271-01	1

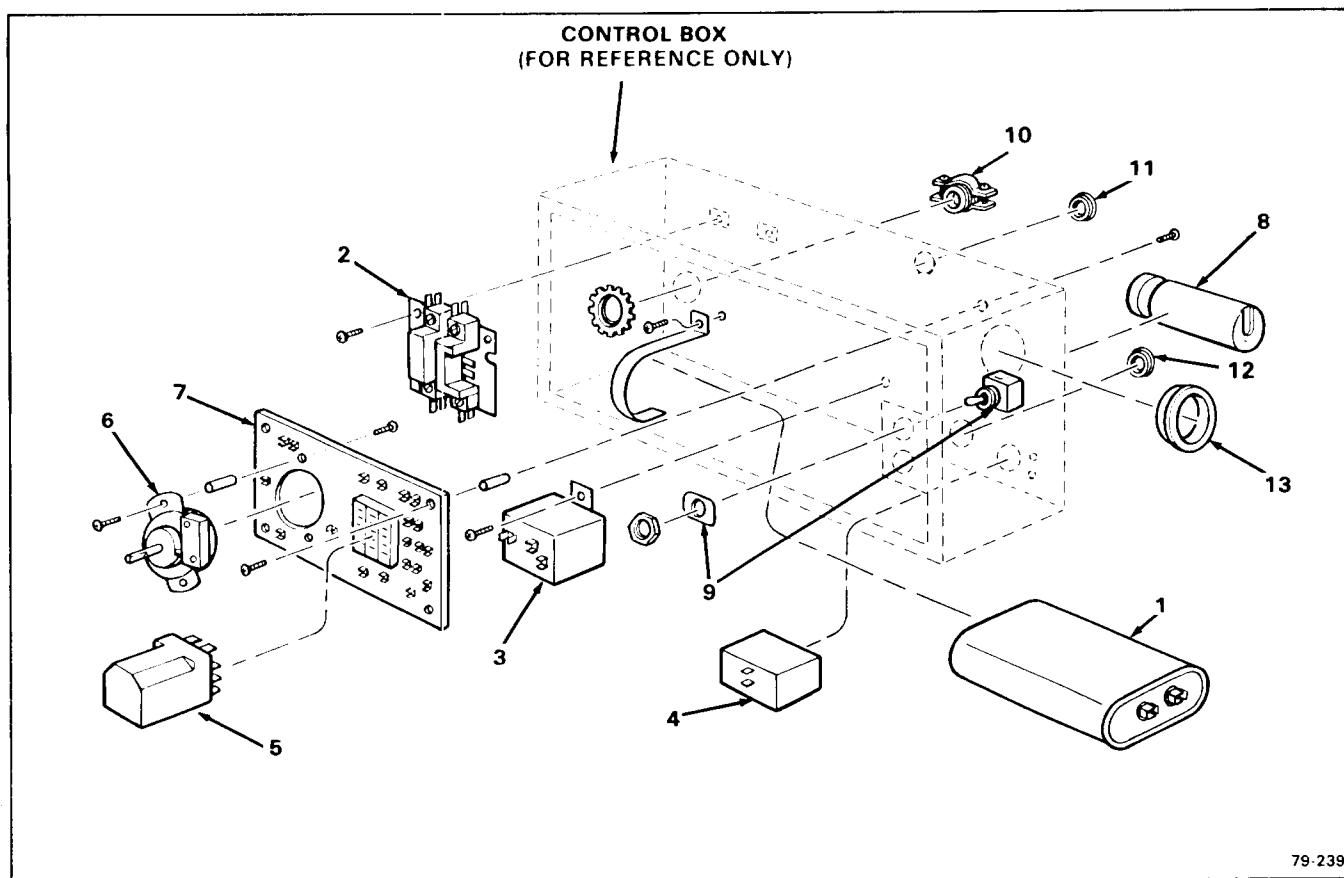

79-239

Figure 8-8. Control Box Assembly

INDEX NO.	DESCRIPTION	Air-Cooled Water Cooled (A/C) (W/C)	PART NUMBER	PHASE	
				1	3
				208	208
230	220				
60	60				
	Control Box Assembly (See Figure/Index 8-2/7 and 8-3/7 for next higher Assembly) * * *		No Number	Ref	Ref
1	Capacitor, Run attaching part, Index 1 Screw, No. 8-32 x 3/8 Phil Recess Pan Hd * * *	A/C & W/C	18-1902-50	1	0
			03-1403-17	1	0
2	Contactor Contactor attaching part, Index 2 Screw, No. 8-32 x 3/8 Phil Recess Pan Hd * * *	A/C & W/C A/C & W/C	12-0739-01 12-2037-01	0 1	1 0
			03-1403-17	2	2
3	Relay, Potential	A/C & W/C	18-1903-40	1	0

Figure 8-8. Control Box Assembly (Cont'd.)

INDEX NO.	DESCRIPTION	Air-Cooled Water Cooled (A/C) (W/C)	PART NUMBER	PHASE	
				1	3
				208 230 60	208 220 60
	attaching part, Index 3				
	Screw, No. 6-32 x 3/8 Phil Recess Pan Hd		03-1403-04	1	0
	Nut, Speed - J-Type		03-1423-01	1	0

4	Control, Pressure	W/C	11-0388-02	1	1
	Control, Pressure	A/C	11-0410-01	1	1
	attaching part, Index 4				
	Screw, No. 6-32 x 3/8 Phil Recess Pan Hd		03-1403-04	2	2

5	Relay	A/C & W/C	12-1879-02	1	1

6	Timer & Switch Assembly	A/C & W/C	12-1979-01	1	1
	attaching parts, Index 6				
	Stand-Off - 7/8-inch lg.		02-2242-01	2	2
	Screw, No. 6-32 x 1/4 Phil Recess Pan Hd		03-1403-02	4	4

7	Board Assembly, Circuit	A/C & W/C	12-1912-01	1	1
	attaching parts, Index 7				
	Stand-Off - 7/8-inch lg.		02-2242-01	5	5
	Screw, No. 6-32 x 1/4 Phil Recess Pan Hd		03-1403-02	5	5

8	Capacitor, Start	A/C & W/C	18-1901-40	1	0

9	Switch, Toggle	A/C & W/C	12-0426-01	2	2

10	Connector, Straight	A/C & W/C	No Number	1	1

11	Bushing, Snap - 1/2-in.	A/C & W/C	12-1213-04	1	1

12	Bushing, Snap - 7/8-in.	A/C & W/C	12-1213-10	1	1

13	Bushing, Snap - 1-1/2-in.	A/C & W/C	12-1213-13	1	1

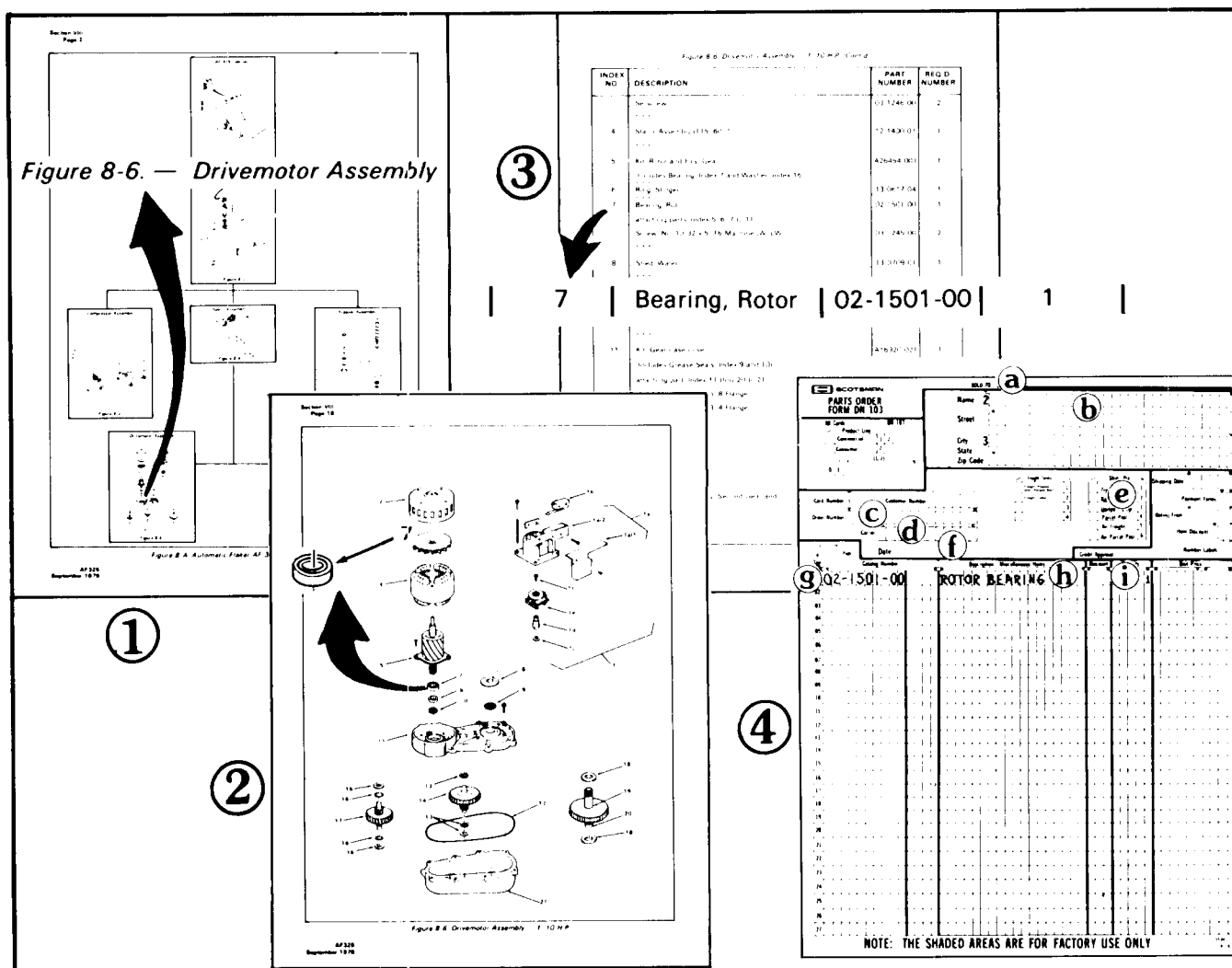

HOW TO USE A SCOTSMAN PARTS MANUAL WHEN ORDERING PARTS FOR ICE SYSTEMS PRODUCTS

IMPORTANT A. All Part Numbers have TEN DIGITS (spaces), required for use in the Computer System. BE SURE to fill in ALL SPACES in the CATALOG NUMBER column, on the Parts Order form as shown above.

B. Enter the QUANTITY of the Parts ordered, in the last digit column under the QUANTITY column heading, the one under the small 55 number, for parts from 1 thru 9. For 10 or more parts use two columns

To be sure you receive the proper parts in the proper quantities, ALWAYS use the PART NUMBERS and DESCRIPTIONS given in the Parts Manuals.

The figures above illustrate the way a Parts Manual would be used, if the Part being ordered were the ROTOR BEARING that is used in the DRIVEMOTOR ASSEMBLY of an AF325 Automatic Flaker, for example.

PROCEDURE:

1. At the beginning of Section VIII, THE PARTS ILLUSTRATIONS AND PARTSLISTS, in each Parts and Service Manual, is Figure 8-A; which, is a flow chart prepared from exploded views in Section VIII. Use the flow chart to quickly determine which Figure contains the Assembly, Component or Part.

FIGURE 1: Since the Part required in the above example is in the DRIVEMOTOR ASSEMBLY, shown as FIGURE 8-6.

2. Open the Manual to page showing FIGURE 8-6.

3. Locate the PART and its INDEX NUMBER on the exploded view illustration.

FIGURE 2: The INDEX NUMBER for the PART is 7.

4. Check the numerical sequence in the associated Parts List following the illustration.

5. LOCATE the INDEX NUMBER 7, in the INDEX NO. column, the first column on the left side of the Parts List page.

FIGURE 3: INDEX NO. 7 is listed as a BEARING, ROTOR in the DESCRIPTION column. The Part Number for the Rotor Bearing is 02-1501-00 as listed in the PART NUMBER column on the right side of the Parts List page. And, one Rotor Bearing is listed in the REQ'D NUMBER column, or that ONLY one of those parts is required for one Drivemotor Assembly.

6. Write an order for the Part. (Use SCOTSMAN Parts Order Form DN103)

FIGURE 4: a. Distributor Name.

b. (Use for DROP-SHIP order ONLY).

c. Distributor Purchase Order Number.

d. Carrier

e. How shipped (Truck, Rail, UPS, etc.)

f. Date ordered

g. Part Catalog Number (use full TEN digits (spaces) listed in Parts Manual, including dashes between numbers.

h. Description - as listed in Parts Manual.

i. Quantity - number of parts ordered. (use far right column)

Figure 8-00. How To Use The Illustrated Parts List.