

# MF6RH INTRODUCTION

**TO THE OWNER OR USER:** The service manual you are reading is intended to provide you, and the maintenance or service technician, with the information needed to install, start up, clean, maintain and service this ice system.

The MF6RH (remote high side) is the freezer portion of a commercial ice machine. It is designed to be connected to the condensing section of a refrigeration system, specifically a supermarket R-502 system. It consists of special tube wrapped evaporators, liquid line valves, valves to isolate each of the two separate ice making sections for service, thermostatic expansion valves, and an EPR valve

## MF6RH TABLE OF CONTENTS

	PAGE
<b>INTRODUCTION</b> .....	1
<b>INSTALLATION</b>	
Specifications.....	2
Location .....	3
Bin.....	4
Electrical .....	5
Plumbing.....	6
Check List.....	7
<b>START UP</b> .....	8
<b>COMPONENT LOCATION</b>	
Refrigeration .....	9
Control Box .....	10
<b>OPERATION</b>	
Refrigeraton .....	11
Water .....	12
<b>MAINTENANCE AND CLEANING</b> .....	13
<b>SERVICE DIAGNOSIS</b> .....	15
<b>REMOVAL AND REPLACEMENT</b>	
Evaporator, Auger, Bearings, Water Seal .....	16
Gear Motor.....	19

*Parts Lists and Wiring Diagram are in the center of this Manual, printed on yellow paper.*

**THIS PAGE  
INTENTIONALLY  
LEFT BLANK**

# MF6RH FOR THE INSTALLER

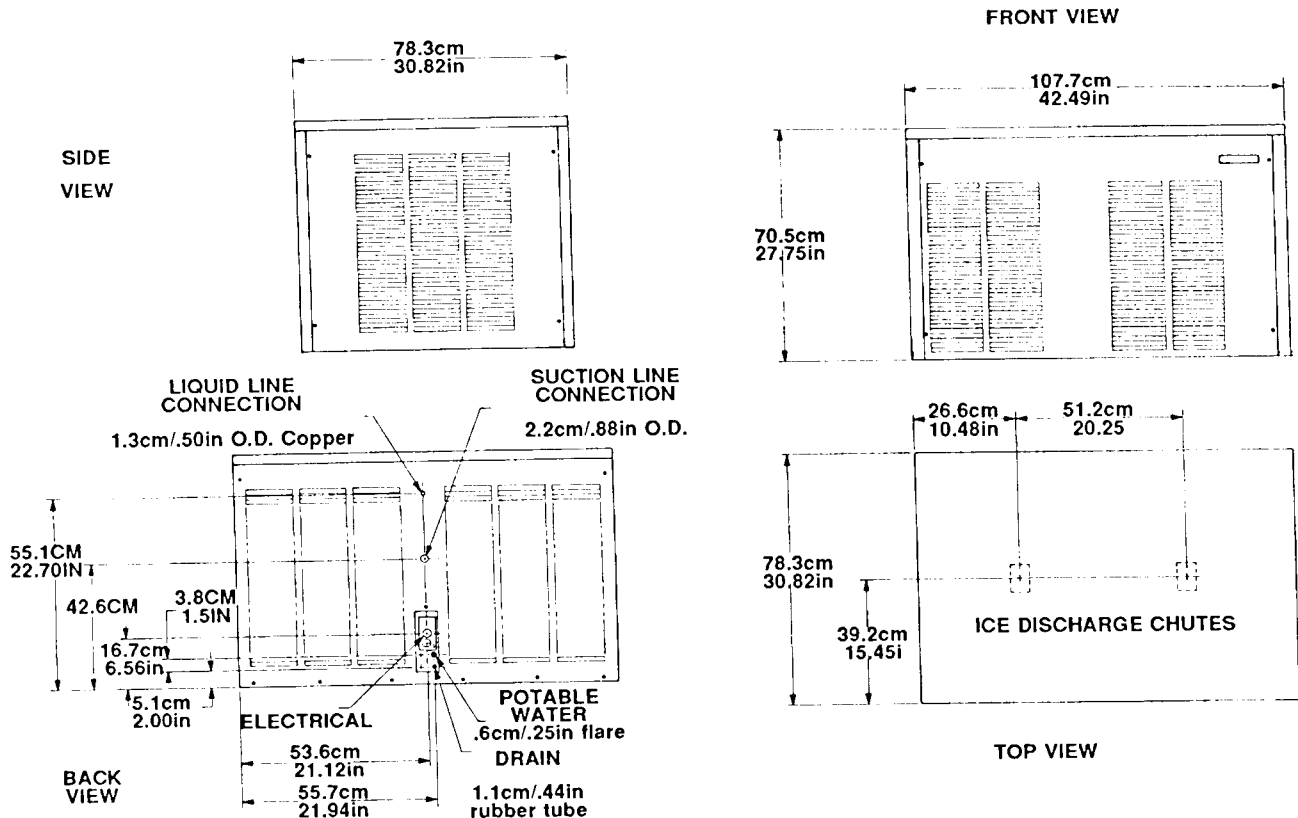

Scotsman reserves the right to make design changes and/or improvements at any time. Specifications and design are subject to change without notice.

Scotsman ice systems are designed and manufactured with the highest regard for safety and performance. They meet or exceed the standards of UL, NSF, and CSA.

Scotsman assumes no liability or responsibility of any kind for products manufactured by Scotsman that have been altered in any way, including the use of any part and/or other components not specifically approved by Scotsman.

## SPECIFICATIONS:

Minimum Circuit Ampacity is used to determine wire size and type per national electric code.

MODEL NUMBER	DIMENSIONS H" X W" X D"	ICECAPACITY 24 HOUR MAX.	ICE TYPE	BASIC ELECTRICAL	NO. OF WIRES	MIN. CIRC. AMPACITY	MAX. FUSE SIZE
MF6RH-32A	27.75 X 42.38 X 30.8	2350 lbs	FLAKE	208-230 /60/1	2	2.47	15

**Installation Limitations:** The MF6RH is designed for indoor installations only. The machine must also be in a controlled environment where the air temperature does not fall below 50° F. or go above 100° F.

The water temperature must be between 40 and 100 degrees F.

The electrical power supply must not drop below -5% of the lowest nameplate voltage or go above 10% of the highest nameplate voltage.

The MF6RH is designed to fit the Scotsman storage bin B-90 and the B-87 extension. Leg kit KLP4 is recommended when using both the B-90 and the BX-87.

# MF6RH FOR THE INSTALLER

## Select the location:

The unit can only be installed indoors within the limitations described on page 2.

The ice machine will have to be connected to the buildings R-502 refrigeration system, check to be sure that the system has enough extra capacity to handle a minimum of an additional 16,000 BTU's per hour

@110<sup>0</sup> F. liquid line temperature. (Assume a 10<sup>0</sup> F. evaporator temperature.)

The unit will also require electrical power, potable water, and a drain.

## Locate the Nameplate:

The nameplate is located on the back panel of the machine, and contains the electrical characteristics particular to the unit being installed.

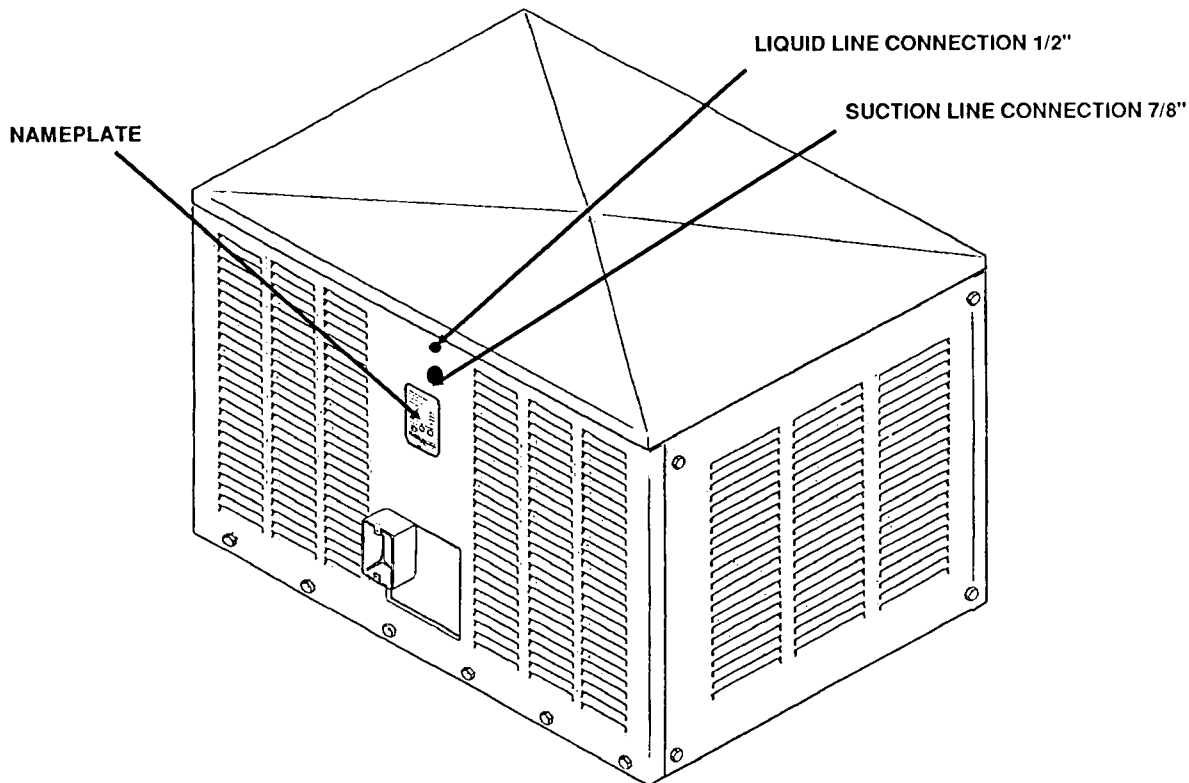

## Refrigeration Installation:

The skills of a refrigeration technician are required to connect the ice machine to the buildings refrigeration system.

//////////////////**CAUTION**//////////////////

**CONNECT TO A R-502 SYSTEM ONLY**

//////////////////

## LOCAL CODES MUST BE OBSERVED

A P-trap should be installed where there will be more than 10' of vertical rise in the suction line.

# MF6RH FOR THE INSTALLER

## Storage Bin:

Scotsman's B-90 bin will be the presumed bin of choice. If using bin extension BX-87, install the heavy duty leg kit KLP4 and place the bin into position.

Remove the paper tape from the bin edge gasket, and install the bin extension onto the B-90.

Remove the paper tape from the bin extension top edge, and using a mechanical lift, install the MF6RH onto the top of the storage bin assembly.

Fasten the ice machine to the bin using (4) 5/16-18 2.5" cap screws. (field supplied)  
See the illustration.

Level the assembly by:

a) turning in or out the adjustable feet in the standard legs, or b) use shims under the heavy duty leg kit.

## Ice Maker:

Install the cube chutes into position, securing them to the spout with the fasteners provided.

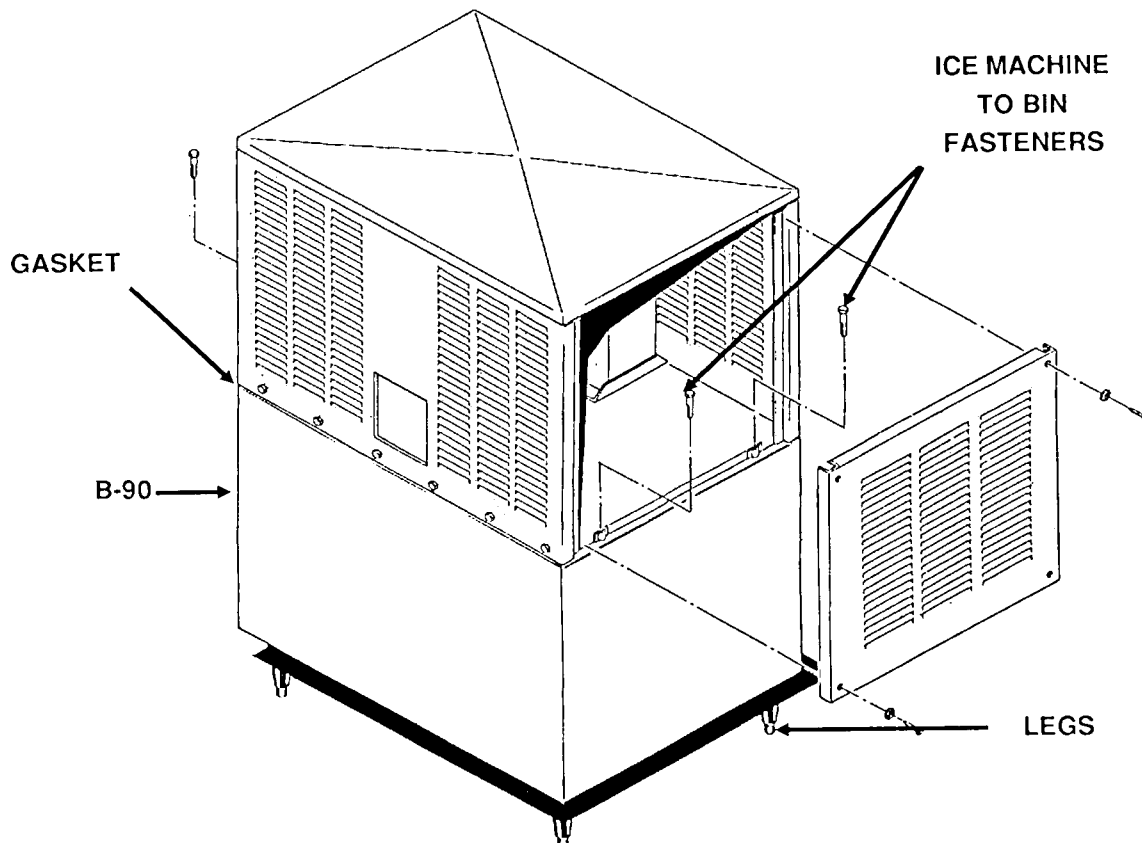

# MF6RH FOR THE ELECTRICIAN

CONFORM TO ALL APPLICABLE CODES

## Electrical Connections:

Locate the Nameplate for the current requirements, and then determine the wire size and type per the National Electric Code. The machine requires a solid chassis to earth ground wire. Refer to the wiring diagram. The ice machine should be connected to its own electrical circuit, and be individually fused.

Voltage, when the unit is under full load, must remain within the limitations listed on page 2. **LOW VOLTAGE CAN CAUSE EQUIPMENT MALFUNCTION AND/OR DAMAGE.**

All external wiring should conform to the national, state, and local electrical code. Usually the services of a licensed electrician will be required.

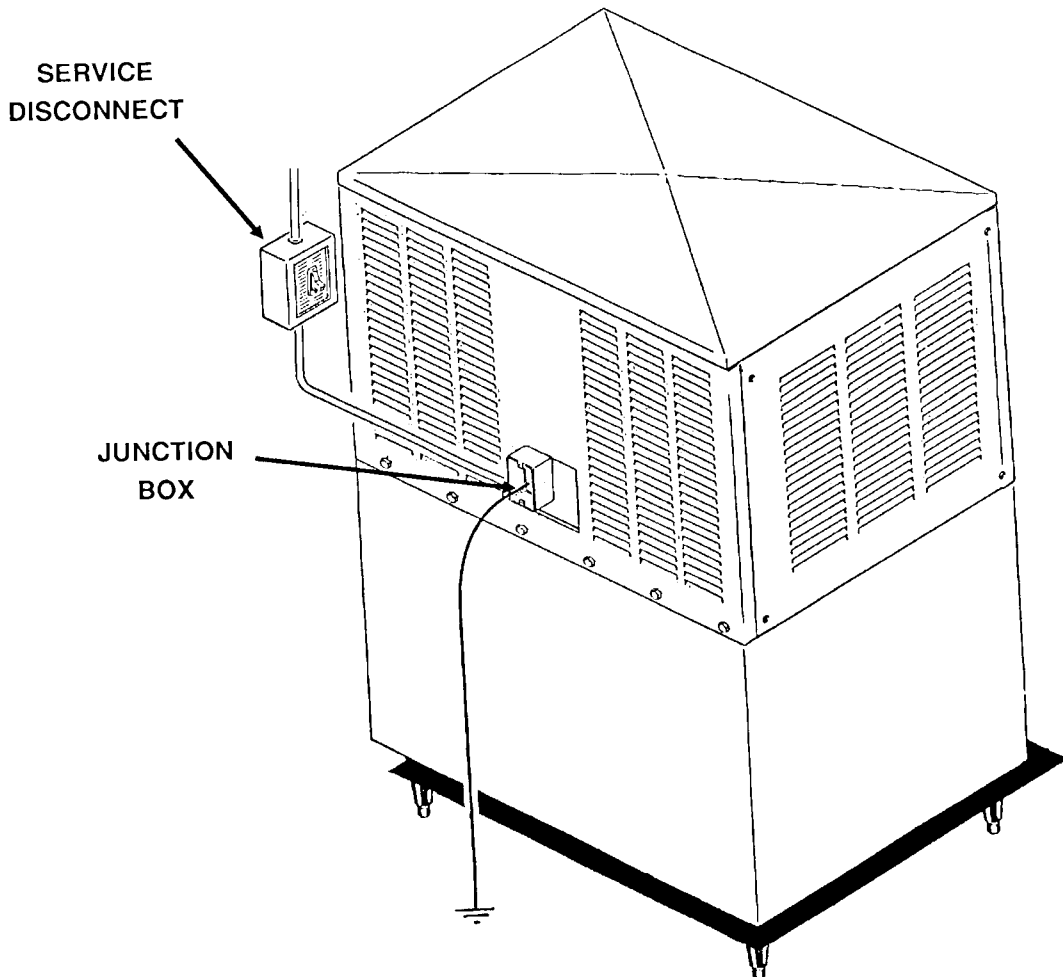

# MF6RH FOR THE PLUMBER

## CONFORM TO ALL APPLICABLE CODES

### Water Supply:

The recommended water supply line is 3/8" OD copper tubing, with a minimum operating pressure of 20 PSIG, and a maximum of 120 PSIG. Connect to cold water using the male flare connection at the back of the machine. Install a shut off valve in an accessible space between the ice maker and the water supply.

### Drain System:

All drains are of the gravity type, and must have a minimum of 1/4" fall per foot of horizontal run. The drains must be installed to conform to local plumbing codes. The use of a vent at the machine and at the bin will allow the system to drain properly.

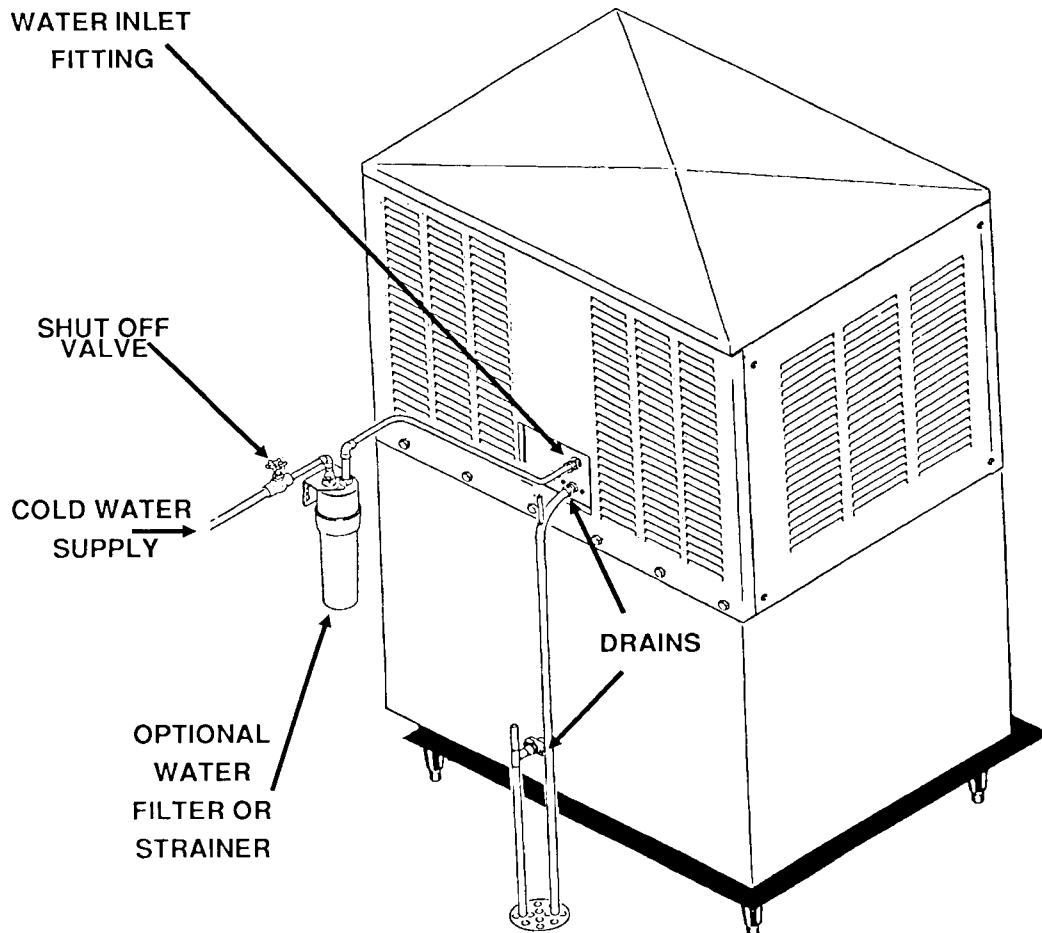

# MF6RH FOR THE INSTALLER

## Final Check List

1. Is the unit installed where the air and water temperatures are within, and will remain within the limitations for the unit?
2. Is there 6" clearance at the rear of the machine for utility connections?
3. Has the water supply line been checked for pressures between 20 and 120?
4. Has the unit been leveled?
5. Has the shipping material been removed from inside the cabinet?
6. Have the cube chutes been installed?
7. Have the electrical connections been made?
8. Have the drains been installed and checked for leaks?
9. Has the refrigeration supply been installed and checked for leaks?
10. Has the bin and cabinet been wiped clean or sanitized?
11. Has the warranty registration card been properly filled out and mailed to the Scotsman Factory?
12. Has the owner been given the service manual and been instructed on how to maintain the icemaker?
13. Has the owner been given the name and telephone number of the local Scotsman service agency?



## MF6RH START UP

1. Remove the top panel, and the front panel.
2. Open the water valve, and observe that the two float reservoirs fill up with water and shut off.
3. Switch on the electrical power.
4. Open the hand valves (in the liquid lines).
5. Open the ball valves (in the suction lines).
6. Switch on one master switch, and observe:
  - . the liquid line valve opens
  - . the gearmotor runs
  - . within a short time, that side of the machine begins to make ice.
  - . water flows from the water reservoir, and the float opens and more water enters the reservoir.
7. Switch on the other master switch, observe that:
  - . the liquid line valve opens
  - . the gearmotor runs
  - . after a short time, ice is produced
  - . water flows from the water reservoir, and the float opens and more water enters the reservoir.
8. With both sides operating, the sight glass should remain full, and the lowside pressure will be about 36-38 PSIG. Gearmotor amp draw should not exceed the nameplate rating.
9. Check the system very carefully for any refrigerant leaks, repair as needed.

# MF6RH REFRIGERATION COMPONENTS

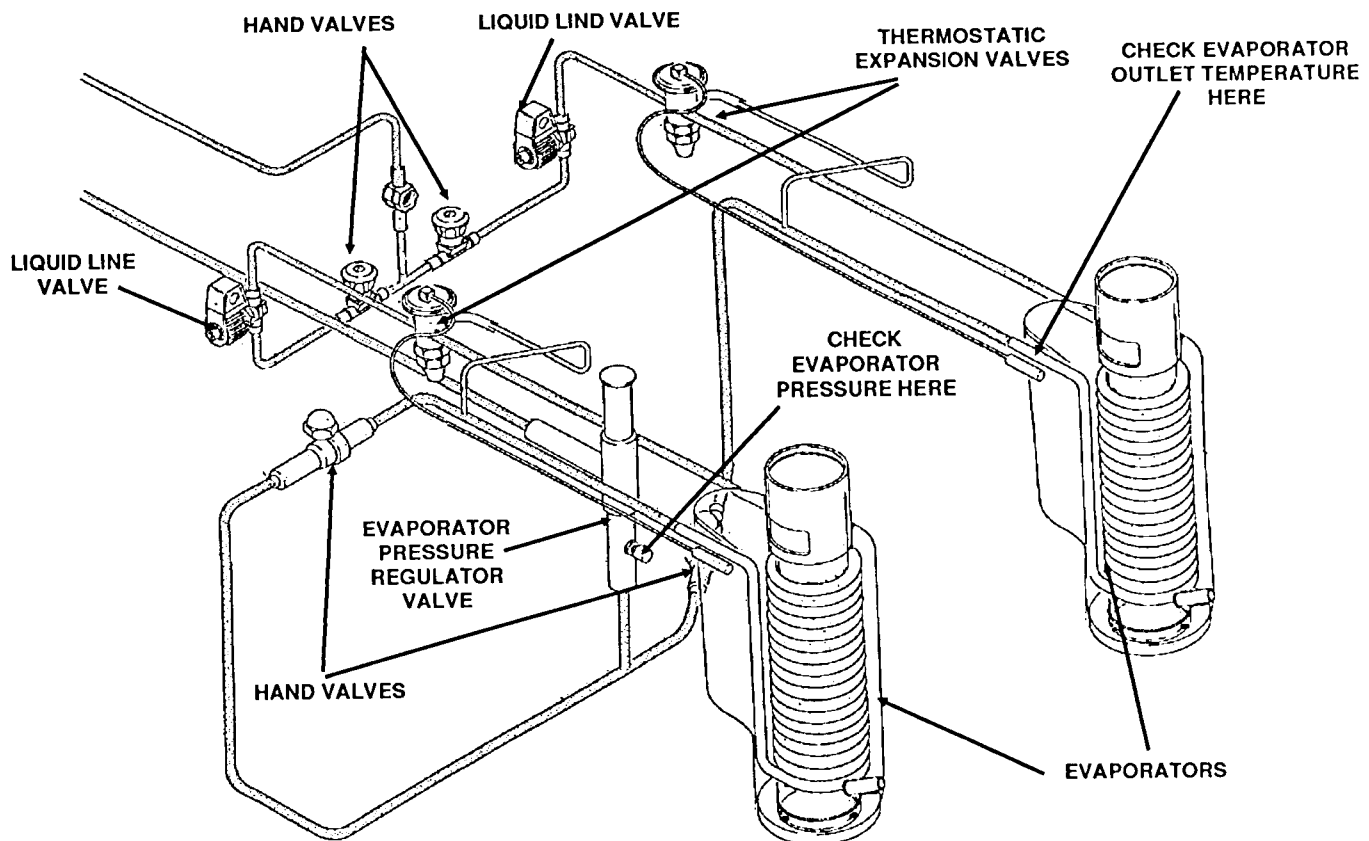

## Liquid Line Valve(s):

These valves operate to turn the ice making process on and off. When the bin thermostat closes, calling for ice, that liquid line valve opens, allowing the refrigerant to flow.

## Evaporator Pressure Regulator Valve:EPR

This valve maintains a constant pressure on its inlet side, (evaporators) regardless of the pressure on the outlet side (suction line). Set at 36-38 PSIG (with both systems producing ice). EPR is **factory set**, adjust only if needed. After adjusting, check TXV superheat.

## Thermostatic Expansion Valve(s):TXV

The metering device of each system, the valve(s) sense the temperature of the suction line and vary the amount of liquid refrigerant that passes through the valve into the evaporator, thus maintaining a

constant level of refrigeration. TXV's are factory set: **Do not adjust unnessesarily.** DO NOT ADJUST TXV UNTIL THE EPR HAS BEEN SET

The superheat setting is 4-8<sup>0</sup>F. Measure the temperature of the evaporator outlet at the TXV bulb, and check the low side pressure at the EPR, then convert the pressure to temperature, (use pressure temperature chart) and subtract from the outlet temperature. Use an electronic thermometer.

## Evaporator(s):

Where the water is frozen into flaked ice. As the water cools, it begins to turn into ice, and the slowly turning auger lifts the ice, as it is being made, and forces it up and out of the "breaker" or spout where the extra water is compressed out of the ice. The ice then drops through the chute, into the storage bin.

# MF6RH CONTROL BOX COMPONENTS

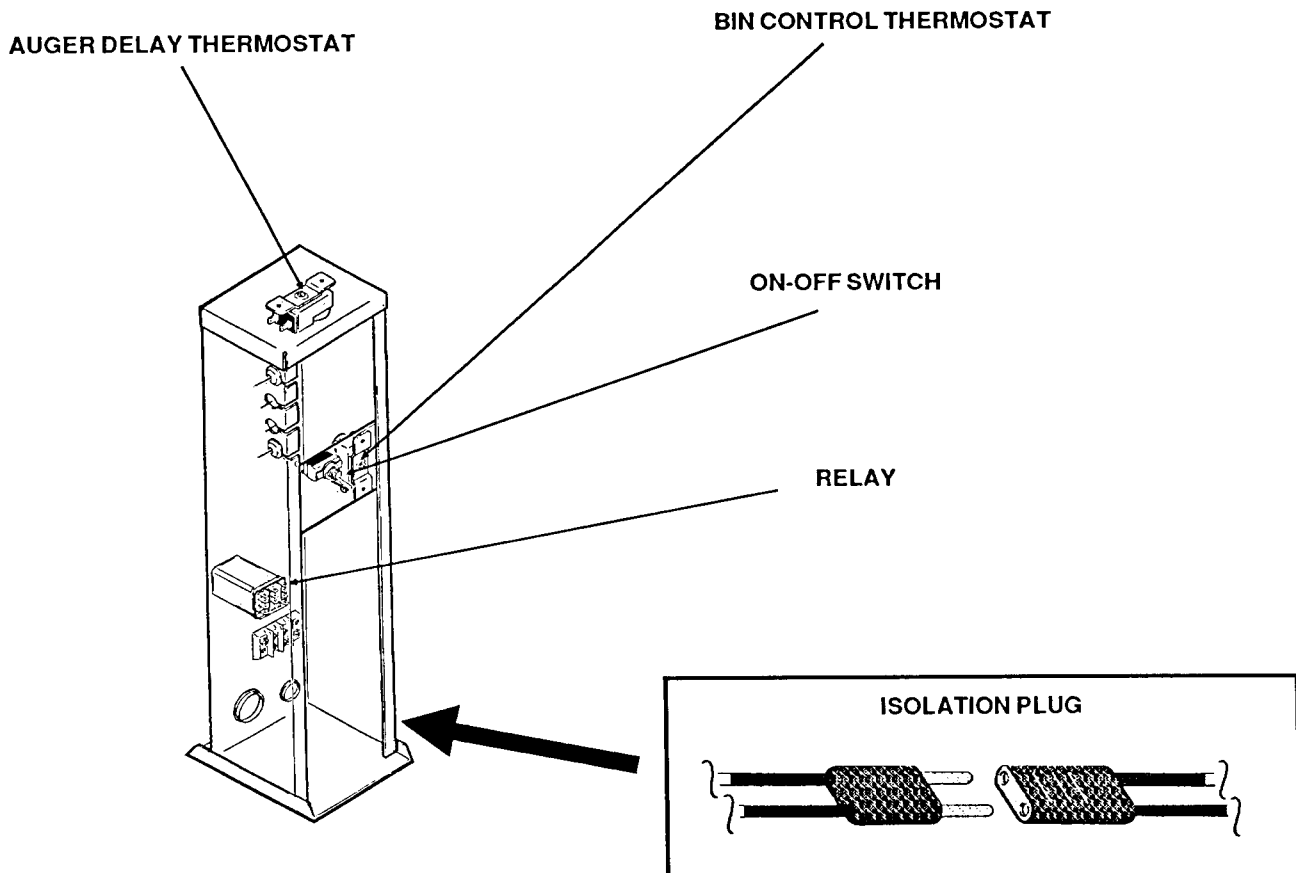

## **AUGER DELAY THERMOSTAT:**

This control senses the temperature of the suction line. It keeps the auger drive motor on after the bin thermostat has opened shutting off the liquid line solenoid and the refrigeration. This clears the evaporator of ice. When the suction line is warm enough, the control opens, shutting off the auger drive motor.

## **BIN CONTROL THERMOSTAT:**

The cap tube of this control is in the ice discharge chute. When ice is in constant contact with the cap tube (bin full) the control opens, shutting off the liquid line solenoid.

## **ON-OFF SWITCH:**

Manual control for each side of the machine. Not a service disconnect.

## **RELAY:**

Conducts power from the bin thermostat to the liquid line valve.

## **ISOLATION PLUG:**

Each system can be electrically isolated from the power supply independently by unplugging this connection. Located near the base of each control box.

# MF6RH OPERATION

REFRIGERATION SCHEMATIC

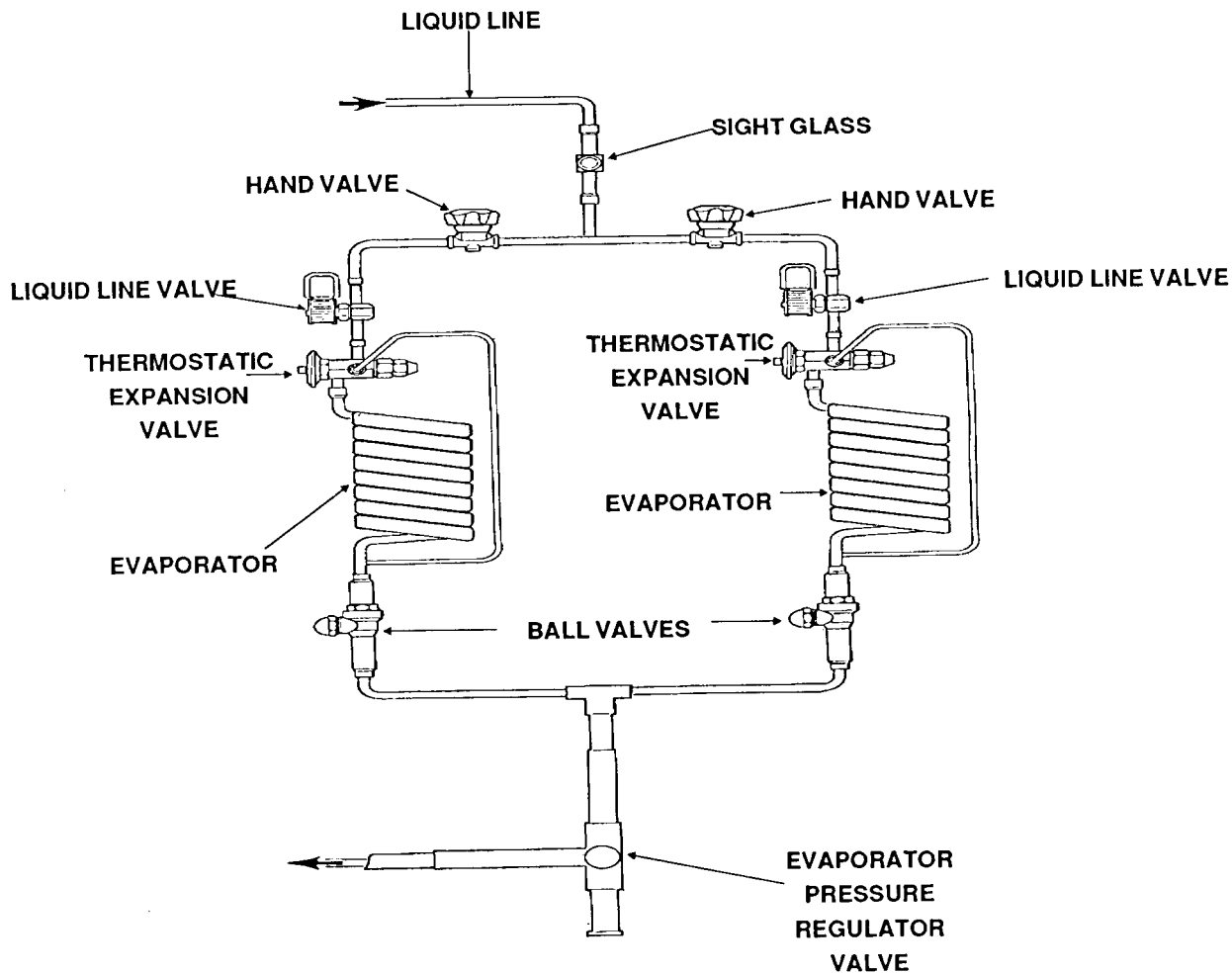

## Refrigeration:

The remote high side supplies high pressure liquid R-502 to the liquid line connection on the ice machine. After the **sight glass**, there are two separate liquid lines, each leading to a **liquid line valve**. When the individual bin thermostat calls for ice (closes) the liquid line valve opens, allowing the liquid refrigerant to enter the expansion valve. The **thermostatic expansion valve** meters the liquid refrigerant into the

**evaporator**, where it boils off (evaporates) and absorbs heat. It then moves through the **ball valve** and into the **evaporator pressure regulator valve**. The EPR valve keeps the evaporator pressure above a predetermined point, even though the suction line pressure of the remote high side system may vary. The refrigerant, now a low pressure gas, moves into the suction line of the remote high side system.

# MF6RH OPERATION

## Water:

There is a common water supply, split into two lines; one for each evaporator.

The water reservoir and float maintain a constant water level in the evaporator.

If the reservoir should overflow, the water will go down the overflow drain.

If the evaporator should leak water, the drip pan drain will collect it, and route it to the drain.

WATER SCHEMATIC

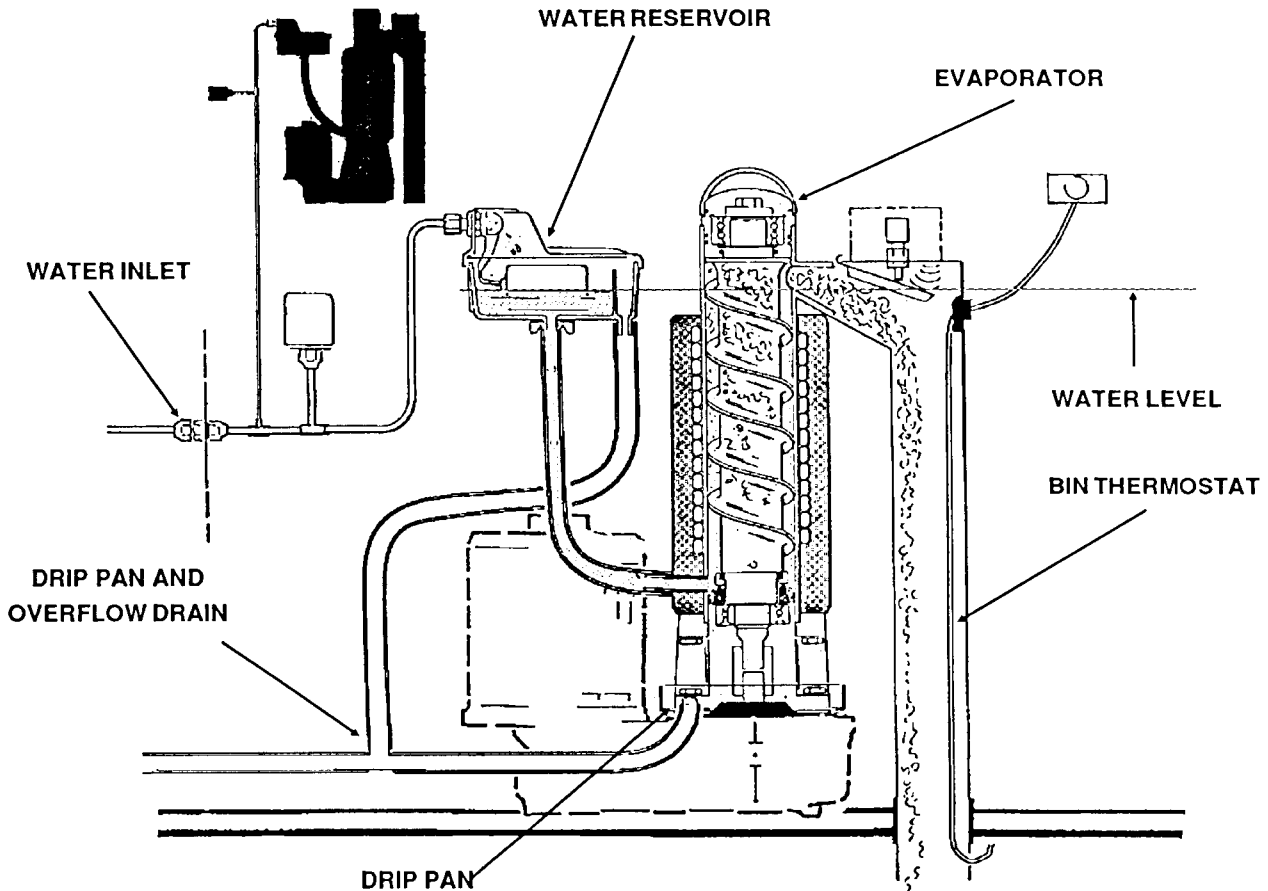

# MF6RH MAINTENANCE AND CLEANING

////////////////////////////////////  
A Scotsman Ice System represents a sizeable investment of time and money in any company's business. In order to receive the best return for that investment, it **MUST** receive periodic maintenance.

It is the **USERS RESPONSIBILITY** to see that the unit is properly maintained. It is always preferable; and less costly in the long run, to avoid possible down time by keeping it clean, adjusting it as needed, and by replacing worn parts before they can cause failure. The following is a list of recommended maintenance that will help keep your machine running with a minimum of problems.

Maintenance and Cleaning should be scheduled at a **MINIMUM** of twice per year.

////////////////////////////////////  
**ICE MAKER:**

The following maintenance should be scheduled at least two times per year. Call your local Scotsman Service Agency.

1. Check and clean or service any optional water treatment devices, if any are installed.
2. Remove front and top panels.
3. Clean the evaporator/auger system using a mixture of Scotsman Ice Machine Cleaner and hot water. This procedure is best done when the bin is empty, because it will produce acidized ice.

a) Mix 12 ounces of Scotsman Ice Machine Cleaner with 3 quarts of hot water. (This is enough for both sides)

////////////////////////////////////  
**WARNING**////////////////////////////////////

**SCOTSMAN Ice Machine Cleaner contains Phosphoric and Hydroxyacetic acids. These compounds are corrosive and may cause burns. If swallowed, DO NOT induce vomiting. Give large amounts of water or milk. Call physician immediately. In case of external contact, flush with water. KEEP OUT OF THE REACH OF CHILDREN.**

////////////////////////////////////

b) Block the float arm up to close off the water supply.

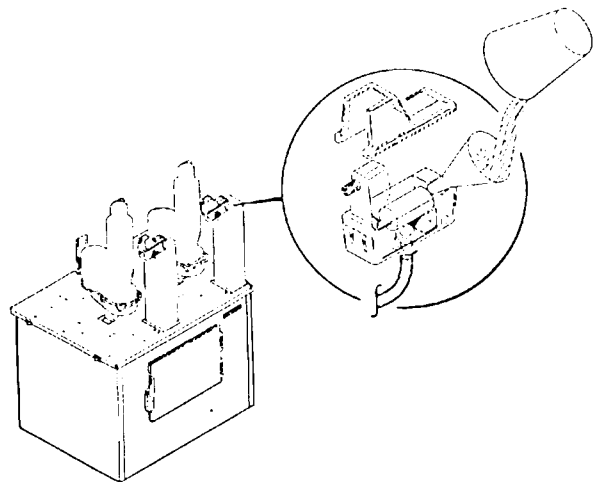

(one reservoir at a time)

c) As the machine is making ice, slowly pour the cleaner solution into the reservoir, maintaining the normal water level in the reservoir.

d) After the solution is half gone, release the float arm and block the float arm in the other reservoir.

e) Pour the remaining solution into the reservoir as in step c.

## MF6RH MAINTENANCE AND CLEANING

f) The ice produced will be acidic, and dirty- **do not use it**-instead melt that ice with several buckets of hot water. This also cleans out the bin drain.

4. Check and tighten all bolts and screws.
5. Oil the drive motor once per year.
6. Check the top bearing.
  - a) Remove rubber cap.
  - b) Remove brass cover, inspect for water, rust, or obvious wear. If in doubt remove auger and check both top and bottom bearing. Replace the water seal if it leaks or if the auger was removed.
7. Check the electrical controls.]
8. Check for water leaks, reapiir as needed.
9. Clean the ice storage bin with soap and water **ONCE PER WEEK**.

Sanitize the bin every 90 days with an approved sanitizer following the directions for that sanitizer.

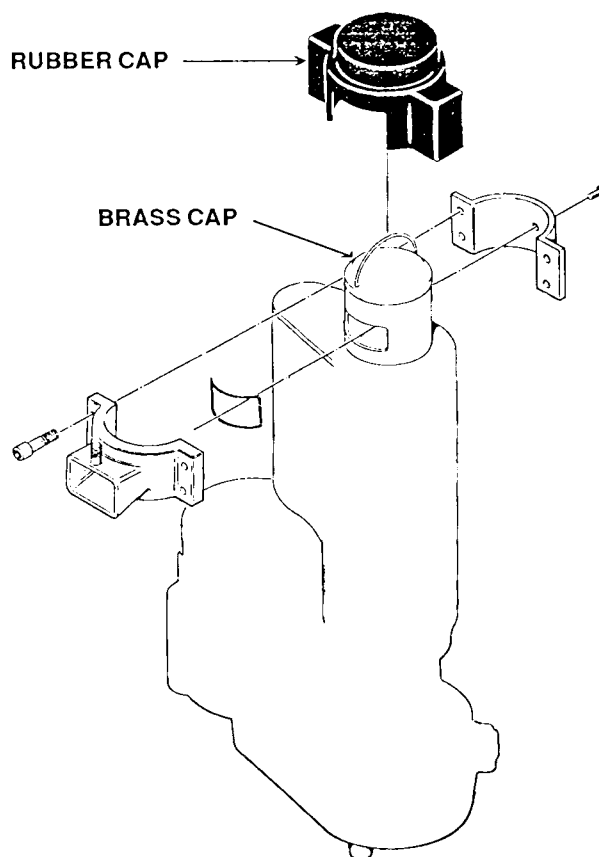

## MF6RH SERVICE DIAGNOSIS

This service diagnosis section is for use in aiding the service agent in diagnosing a particular problem. The following chart lists corrections for the causes of known symptoms.

<u>PROBLEM</u>	<u>CAUSE</u>	<u>CORRECTION</u>
Water leak.....	Water seal leaks, .....	Replace seal
	Water reservoir cracked.....	Replace reservoir
	Tubing leaks .....	Check clamps, replace tubing
	Drain fittings leak .....	Replace/check drain lines and connections.
Excessive noise .....	Dirty evaporator.....	Clean with Scotsman cleaner, or if very dirty remove auger, sand evaporator wall and polish auger.
	Lack of water .....	Check float, and filter if used.
	Wear in gearmotor .....	Replace parts in gearmotor as required.
	Worn evaporator bearings .....	Replace bearings
Low ice production.....	Dirty evaporator.....	Clean with Scotsman Cleaner.
	Both systems not on:	
	Bin control open .....	Replace bin control
	Liquid line valve not opening.....	Check or replace valve.
	TXV not metering .....	Check or replace valve.
	Both systems on, no ice from one:	
	Auger not turning.....	Check gearmotor and coupling
TXV not metering .....	Check or replace valve.	
Liquid line valve closed.....	Check/replace valve	
Unit does not run (both sides) .....	Check power supply.....	Restore power
	Check water supply .....	Restore water
Unit does not run (one side).....	Check bin thermostat .....	Replace
	Check chute switch.....	Replace
Chute switch shuts unit off .....	Check bin thremostat .....	Replace



# MF6RH REMOVAL AND REPLACEMENT

## EVAPORATOR COMPONENTS

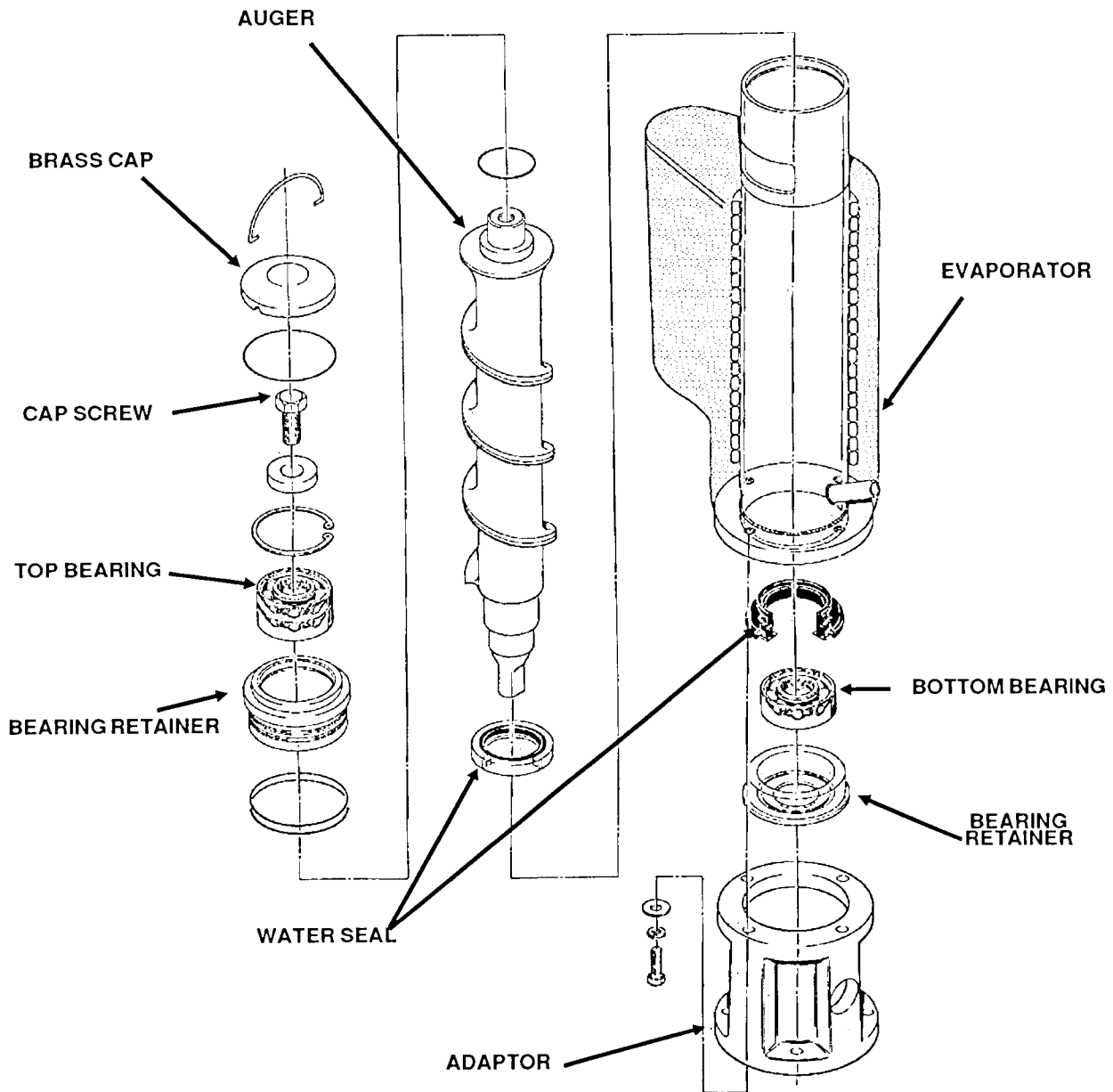

# MF6RH REMOVAL AND REPLACEMENT

////////////////////WARNING////////////////////

Be sure that the electrical power supply is OFF before proceeding with removal procedures.

////////////////////

////////////////////CAUTION////////////////////

SHUT OFF water supply to icemaker

////////////////////

## Auger, Water Seal, and Bearings:

1. Remove screws and the top panel.
2. Remove rubber cover from evaporator.
3. Remove two wing nuts, and separate the ice chute from the spout.
4. Remove 4 cap screws and separate the spout assembly from the spout plate.
5. Remove phillips-head screw from the spout plate.

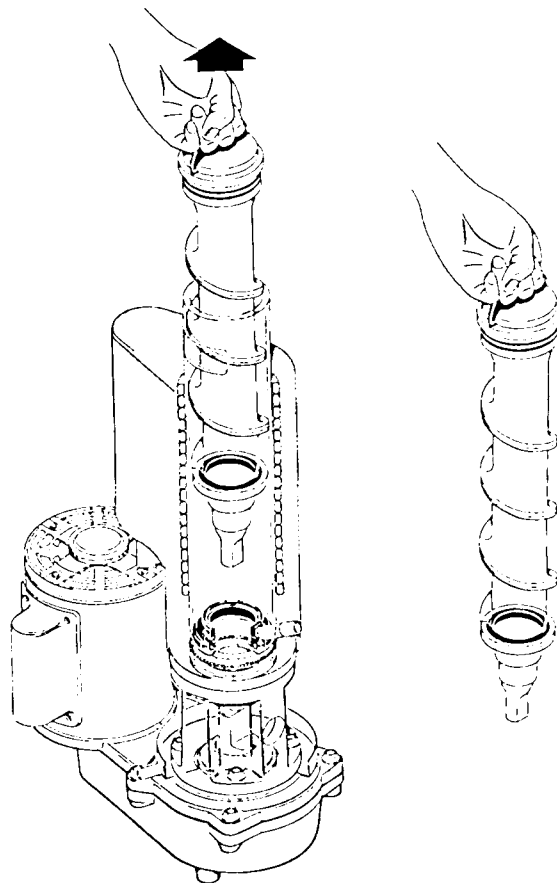
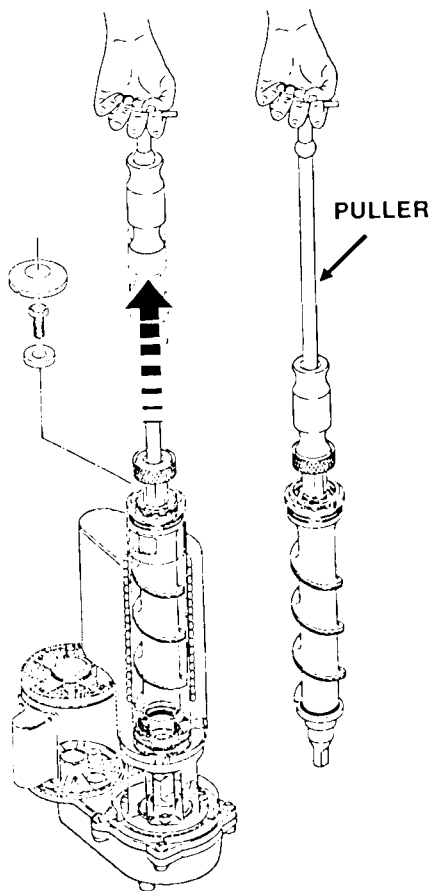

6. Grasp the wire handle at the top of the freezer assembly and pull out the auger with the attached top bearing retainer.

NOTE: The bearing retainer fits very tightly inside the evaporator, so it may have to be worked back and forth to loosen it. If the auger seems stuck, you can either use a slide-hammer type puller as illustrated, or proceed to step 10 to get to the bottom of the auger, and then with a dead-blow hammer or a plastic mallet, tap the bottom of the auger to break it loose.

# MF6RH REMOVAL AND REPLACEMENT

7. Remove the brass cap from the auger.
8. Remove the cap screw from the top of the auger, then remove the bearing retainer from the auger.
9. Check the bearing for rough spots, or excessive play.

To replace the bearing:

- a) remove snap ring from the bearing retainer.
- b) drive or press out the bearing

NOTE: Any time the auger is removed the water seal should be replaced. Any time a bearing is replaced, the other bearing should also be replaced.

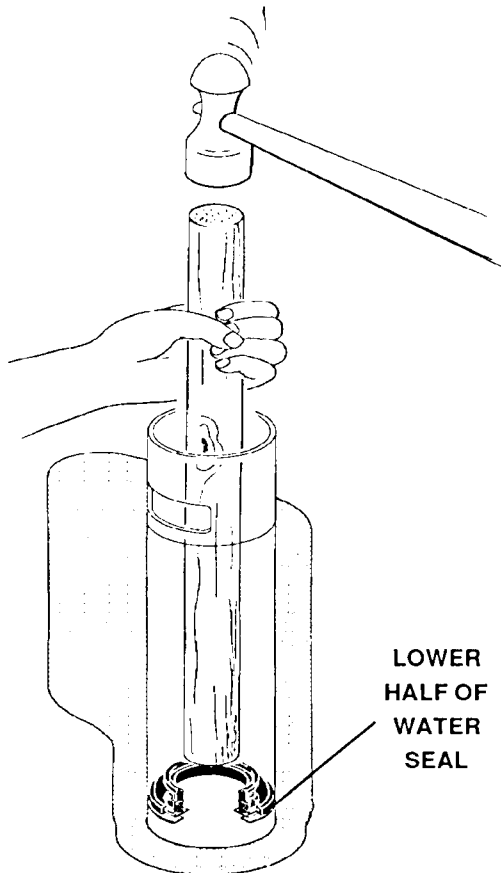
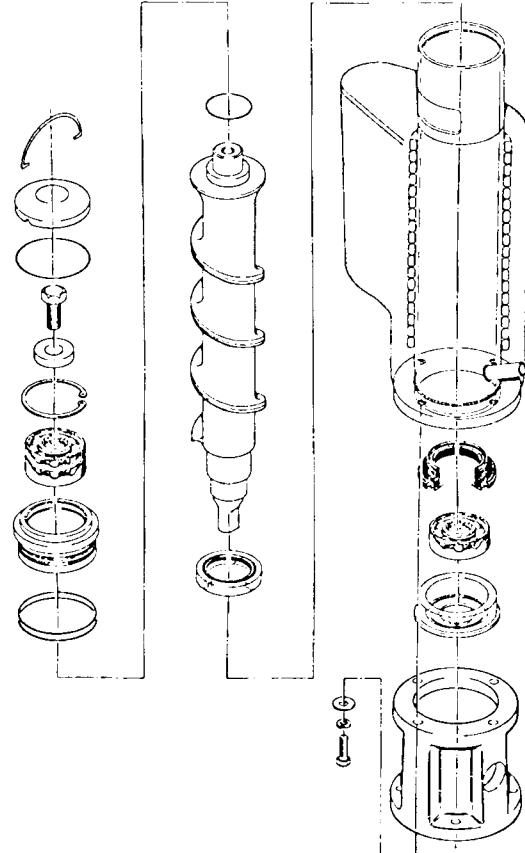

11. Lift up the freezer, and remove the four cap screws holding the adaptor stand to the freezer.

10. To replace the bottom bearing and water seal, remove the four cap screws holding the adaptor stand to the gear reducer.

12. With a dowel or rod, tap out the water seal, and the bottom bearing. See the illustration.

NOTE: If the water seal has been leaking for a long time, water may have gotten into the gear motor case. It would be wise to open up and inspect the gearmotor.

# MF6RH REMOVAL AND REPLACEMENT

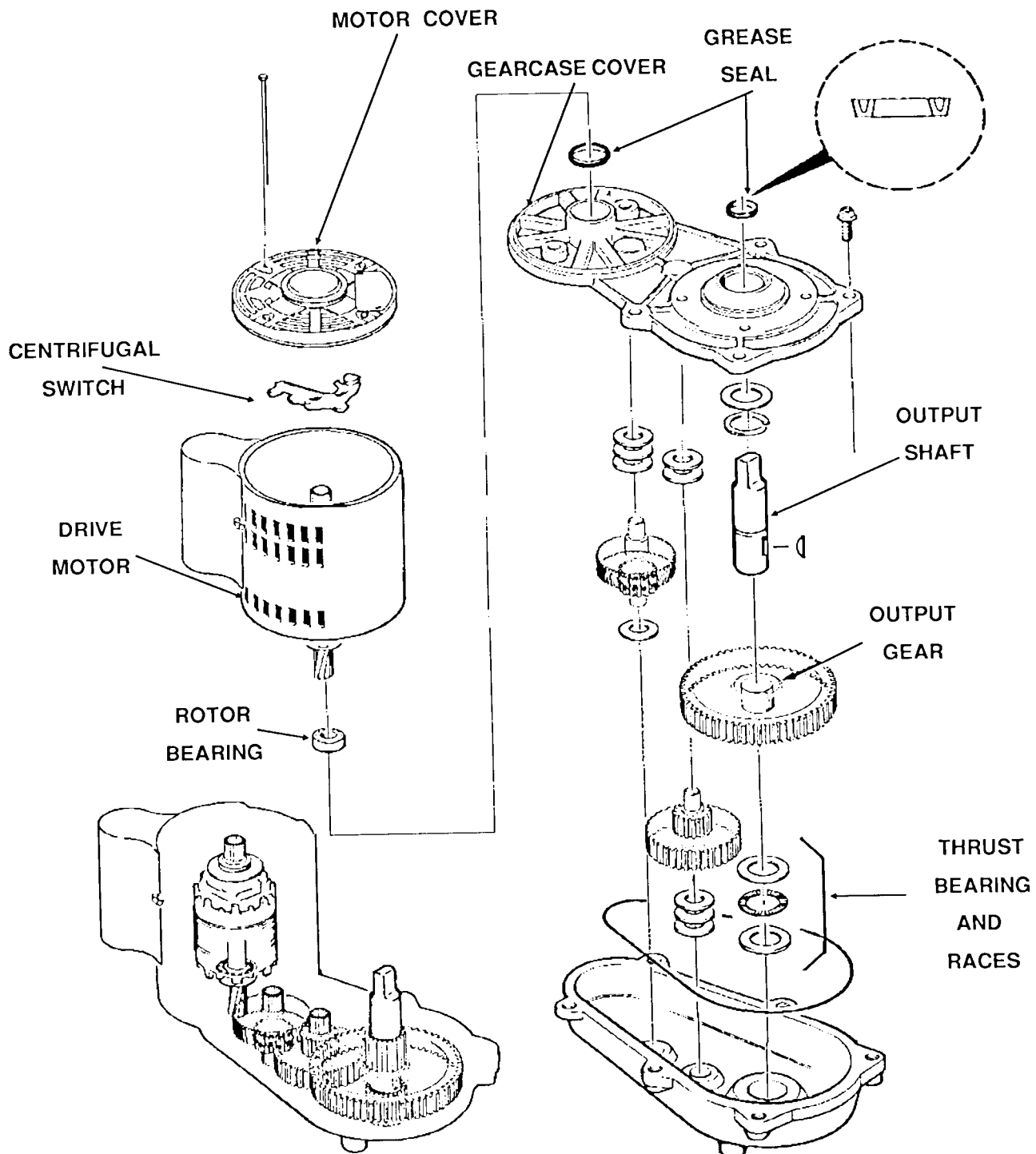

# MF6RH REMOVAL AND REPLACEMENT

## GEARMOTOR:

//////////////////**WARNING**//////////////////

**Disconnect electrical power before proceeding with these repair steps.**

////////////////////////////////////

### To remove just the auger drivemotor:

1. Disconnect electrical power leads from the motor.
2. Unscrew four cap screws securing motor to gearcase.
3. Lift off motor winding from the gear case.
4. Use a pry bar, or insert a bolt into the shaft and pull the rotor out of the gear case.
5. Examine grease seal in gearcase. Replace if worn. Add grease to seal and bearing housing before reassembly.

To replace, reverse the removal procedures.

NOTE: Motors must be exchanged complete. DO NOT MIX ROTORS, HOUSINGS OR WINDINGS.

## GEARMOTOR ASSEMBLY:

### Removal:

1. Remove 4 cap screws holding freezer to gearcase, and lift freezer out of the way.
2. Disconnect the electrical leads from the drivemotor.
3. Remove bolts holding gearmotor plate to the machine base.
4. Lift the gearmotor from the machine base.

To replace the gearmotor assembly, reverse the removal procedure.

### Repair of the Gearmotor Assembly:

1. After removing the gear motor assembly from the ice machine, remove the 6 cap screws holding the two gearcase halves together.

2. Pry the two cases apart, inspect the internal parts, look for:

Condition and quality of the lubricant (the proper oil level is near the top of the output (largest) gear.

Gear and gear shaft condition

Woodruff key between output gear and shaft

Grease seals

Vent hole open

All bearings good

Be sure to count and retain the spacer washers as they come out of the gearbox

Replace the parts as required, using the part numbers found in the parts list in this manual. Replace the gears into a clean bottom gearcase, replacing the spacer washers in the same quantity as they were upon disassembly. If no count was kept, refer to the parts illustration.

Note: Some bearing grease should be placed in all bearings before assembly to insure proper lubrication upon start up.

To reassemble:

1. Set top gearcase on gears and spacers and oil.
2. Replace gearcase cover. Drive in alignment pin before tightening screws and torque the screws to 250 inch pounds.
3. Bench test the gearmotor assembly.

Test for noise, amp draw (must not be in excess of nameplate amps) and oil leaks.

Return gearbox to the unit. Be certain all mountin surfaces are clean and reassemble gearbox to chassis and freezer assembly.