

REMOTE CLOSED LOOP SYSTEM

TABLE OF CONTENTS

| | |
|--|----|
| Table of Contents | 1 |
| List of Illustrations | 1 |
| Specifications | 2 |
| GENERAL INFORMATION & INSTALLATION | |
| Introduction | 3 |
| Unpacking and Inspection | 3 |
| Location and Leveling | 3 |
| Interconnecting Tubing | 4 |
| Electrical Connection | 8 |
| Final Check List | 8 |
| START UP OPERATION | |
| Pre-Start | 9 |
| Start Up | 10 |
| PRINCIPLES OF OPERATION | |
| Icemaker | 11 |
| Remote Unit | 11 |
| Electrical | 11 |
| Stacking Kit | 11 |
| ADJUSTMENT, REMOVAL & REPLACEMENT PROCEDURES | |
| Circulating Pump and Motor Assembly | 13 |
| Fan Blade and Fan Motor | 13 |
| Manifold Solenoid By-Pass Valve and Assembly | 13 |
| MAINTENANCE & CLEANING INSTRUCTIONS | |
| General | 14 |
| Icemaker | 14 |
| Remote Unit | 14 |
| Sanitizing Instructions | 14 |
| SERVICE DIAGNOSIS | |
| Remote Condenser System | 15 |
| WIRING DIAGRAM | |
| Wiring Diagram RCLS-2B, KRCL115, KRCL230 | 16 |
| Wiring Diagram RCLS-2A, KTCL-1, KTCL-2, KTCL-3, KTCL-4 | 22 |
| PARTS ILLUSTRATIONS AND PARTS LISTS | |
| General | 17 |
| How to Order Parts and Accessories | 17 |
| Description | 17 |
| Test Kit | 24 |

LIST OF ILLUSTRATIONS

| | |
|---|----|
| Specifications Remote Closed Loop System | 2 |
| Location, Remote Unit | 4 |
| Warm Climate Performance Improvements | 5 |
| Interconnecting Tubing, Two MH750 Nugget Ice makers | 6 |
| Interconnecting Tubing, Stacking Modular Cubers | 7 |
| Cooling Cycle | 12 |
| Wiring Diagram | 16 |
| Major Assemblies | 18 |
| Manifold, By-Pass Valve Assembly | 19 |
| Stacking Kit Assembly | 19 |
| Circulating Pump, RCLS "B" | 20 |
| RCLS "A" | 21 |
| KTCL1, KTCL2, KTCL3, KTCL4, (RCLS "A") | 22 |
| RCLS "A" Model Pump Assembly | 23 |

**THIS PAGE
INTENTIONALLY
LEFT BLANK**

REMOTE CLOSED LOOP SYSTEM SPECIFICATIONS RCLS15 and RCLS30

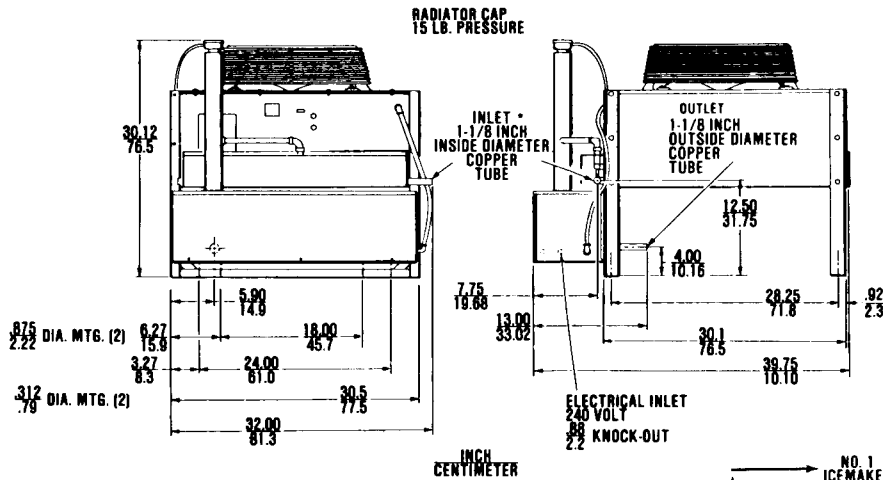

* SOME MODELS HAVE A 7/8 INCH OUTSIDE DIAMETER TUBING INLET.
USE 1-1/8 INCH OUTSIDE DIAMETER COPPER TUBING FOR INTERCONNECTING TUBING.

RCLS "B" MODEL ONLY

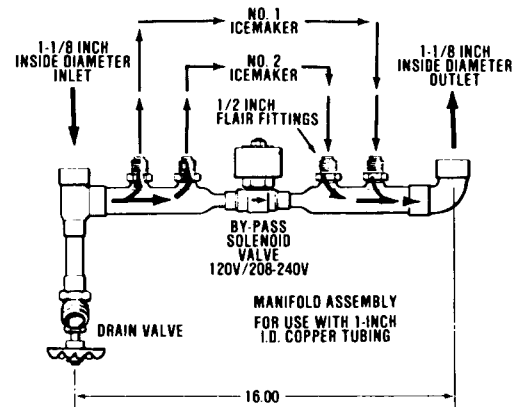

SEE DATA PLATE for MODEL NUMBER, SERIAL NUMBER and ELECTRICAL Specifications. Locate DATA PLATE on the upper left front panel.

| | |
|---------------|--|
| MODEL NUMBER | |
| SERIAL NUMBER | |

OPTIONS:

Kit required when 2 icemakers are installed:
KRCL115: for use with (2) 115 volt icemakers.
KRCL230: for use with (2) 230 volt icemakers.



IMPORTANT OPERATING REQUIREMENTS

| | Minimum | Maximum |
|------------------|---------|---------|
| Air Temperatures | -20° F | 100° F |
| Supply Voltage | 207 V | 253 V |

IMPORTANT

THE FOLLOWING HEAT TRANSFER FLUID MUST BE USED FOR PROPER OPERATION AND FREEZE PROTECTION

| LOWEST OUTDOOR TEMPERATURE EXPECTED | HEAT TRANSFER FLUID REQUIRED |
|-------------------------------------|------------------------------|
| + 32° F | DISTILLED WATER |
| + 10° F | UNDILUTED SCOTFREEZE K RED |
| - 30° F | UNDILUTED SCOTFREEZE K BLUE |

FAILURE TO USE THE RECOMMENDED HEAT TRANSFER FLUID WILL VOID THE SCOTSMAN WARRANTY

17-1567-01

The Remote Closed Loop System has been engineered to our own rigid safety and performance standards. The Underwriters Laboratories, Inc., (UL) Listing Mark signifies that its construction and design have been inspected and tested by them. UL inspectors also periodically examine production icemakers at the factory, to assure continued compliance.

To retain the safety and performance built into this icemaker, it is important that installation and maintenance be conducted in the manner outlined in this manual.

GENERAL INFORMATION AND INSTALLATION

I. INTRODUCTION

This manual provides the specifications and the step-by-step procedures for the installation, start up, operation, maintenance and cleaning for the Scotsman RCLS 15 and RCLS 30 Remote Closed Loop System "A" and "B" Model.

The Scotsman Remote Closed Loop System is a quality designed, engineered, constructed and thoroughly tested heat removal system, providing the utmost in flexibility to fit the needs of a particular user.

Separate sections detail more specifically: General Information & Installation; Start Up Operation; Principles of Operation; Adjustment and Removal and Replacement Procedures; Maintenance and Cleaning Instructions; Service Diagnosis; Wiring Diagrams; and, the Illustrated Assemblies and Parts Lists.

DESCRIPTION

The Scotsman Remote Closed Loop System removes heat collected in the icemaking process from within the building. This cuts water and sewer costs by eliminating wasted water, and also relieving the air conditioning load.

II. UNPACKING AND INSPECTION CONTROL

1. Call your authorized Scotsman Distributor or Dealer, for proper installation. He's listed under ICE MAKING EQUIPMENT and MACHINERY in the yellow pages of the telephone book.
2. Visually inspect the exterior of the shipping container and skid and note any severe damage. File a concealed damage claim subject to internal inspection, with carrier representative present.
3. BEFORE removal of any panels or packing, carefully remove the shipping bolts and the shipping base or skid.
4. Remove screws and shipping tape, and the service panel from the chassis. Notify carrier of any concealed damage, and file a claim as stated in step 2 above.
5. Remove all internal support packing and tape within the unit.
6. Check to see that the fan blade moves freely and does not rub or touch any of the components.
7. See NAMEPLATE on the upper front left corner of remote unit.

8. Remove the manufacturer's Registration Card from the front of the manual and fill in all spaces including Model Number and Serial Number taken from the nameplate. Forward the completed, self-addressed registration card to the SCOTSMAN factory.

TO INSTALL A REMOTE CLOSED LOOP SYSTEM:

III. LOCATION AND LEVELING

Installation should meet local and state electrical, plumbing and building codes.

Prior consideration for location of remote closed unit shall include:

- a. Roof mount installation of the remote unit must be to the roof manufacturer's specifications. Arrange for the services of the Bonded Roofing Contractor for the planning and the installation of the remote unit. The roofing contractor may also be involved in the location and the service outlets for electrical and plumbing connections.
- b. Well ventilated location ABOVE icemaker(s).
- c. Separate 230/60/1 electrical source for the remote unit and a separate electrical source for each icemaker. See IV. ELECTRICAL CONNECTIONS.

Interconnecting tubing for remote closed loop system with one or two icemakers cannot exceed 100 equivalent linear feet. See V. INTERCONNECTING TUBING.

Extreme warm climate installation may require extra caution in location, avoid hot, sunny locations, seek shaded areas. Use natural trade winds to your advantage.

The use of a structure to shade the remote unit from direct sun exposure and/or a stand extending the remote unit an additional 18 inches above the roof, will improve icemaking performance. DO NOT block air circulation.

1. Position icemakers and RCLS Unit in the selected permanent locations. Components must be installed level and RCLS fastened to location. When two icemakers are installed, each must be installed in the same location, stacked, or side by side.

REMOTE CLOSED LOOP SYSTEM GENERAL INFORMATION AND INSTALLATION

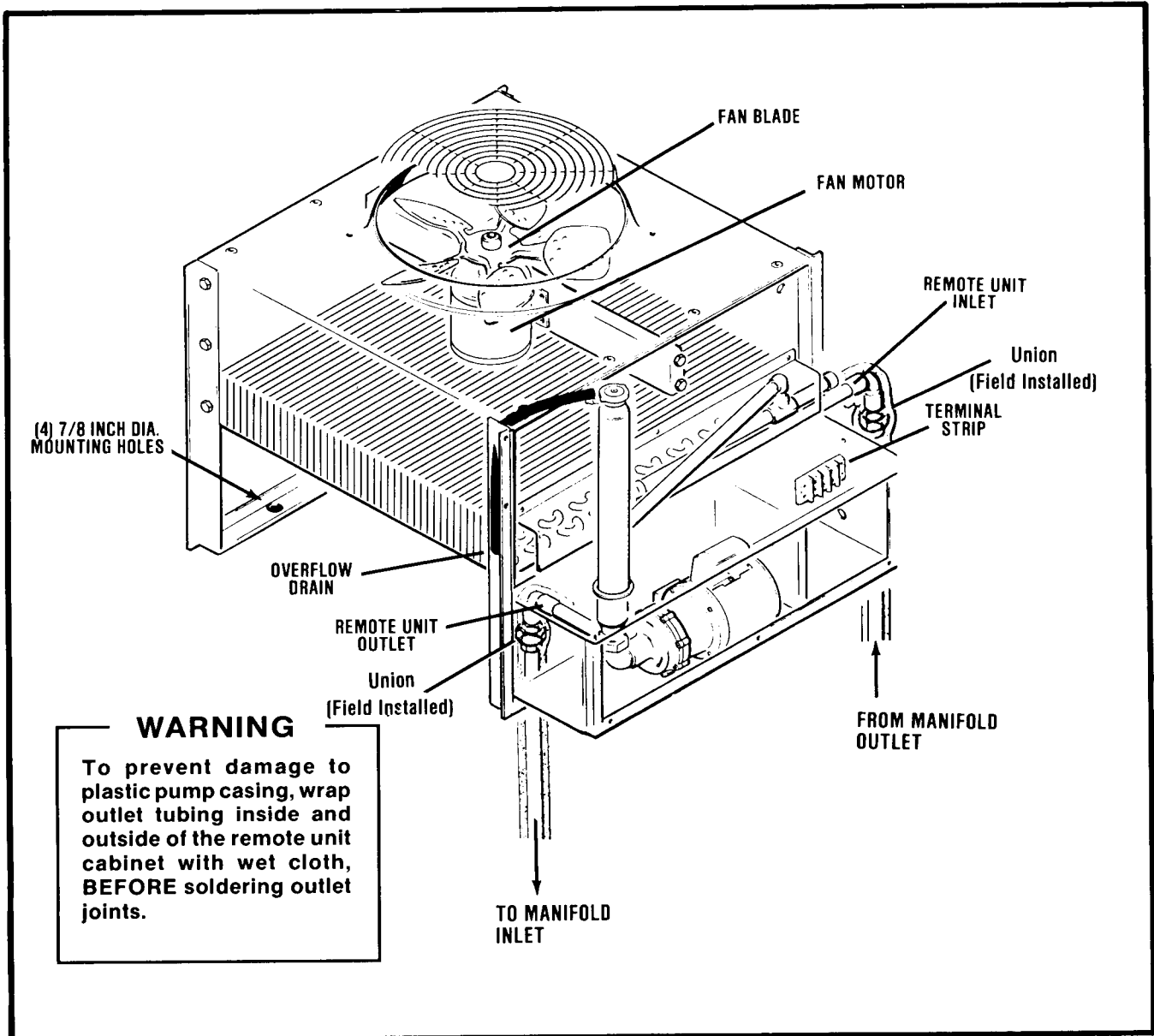

Location, Remote Unit.

IV. INTERCONNECTING TUBING

Installation should meet local and state plumbing codes, contact your local plumber for installation services.

Interconnecting tubing for remote closed loop system with one or two icemakers cannot exceed 100 equivalent linear feet (pipe fittings, tees, elbows and gate valves) of 1-inch I.D. Copper Tubing. Ice makers must be installed in same location, stacked or side by side.

CAUTION

Use COPPER TUBING ONLY, not galvanized pipe or fittings.

WARNING

For peak operating efficiency, 1-inch I.D. tubing and fittings must be used in the shortest and straightest routing throughout the entire system.

Manifold/Icemaker connections must not exceed a MAXIMUM length of 3-feet of MINIMUM size 1/2-inch tubing.

EQUIVALENCE CHART (Equal to linear feet)

| | |
|------------|-----|
| Elbow | 1.8 |
| Tee | 5.2 |
| Gate Valve | 1.2 |

REMOTE CLOSED LOOP SYSTEM GENERAL INFORMATION AND INSTALLATION

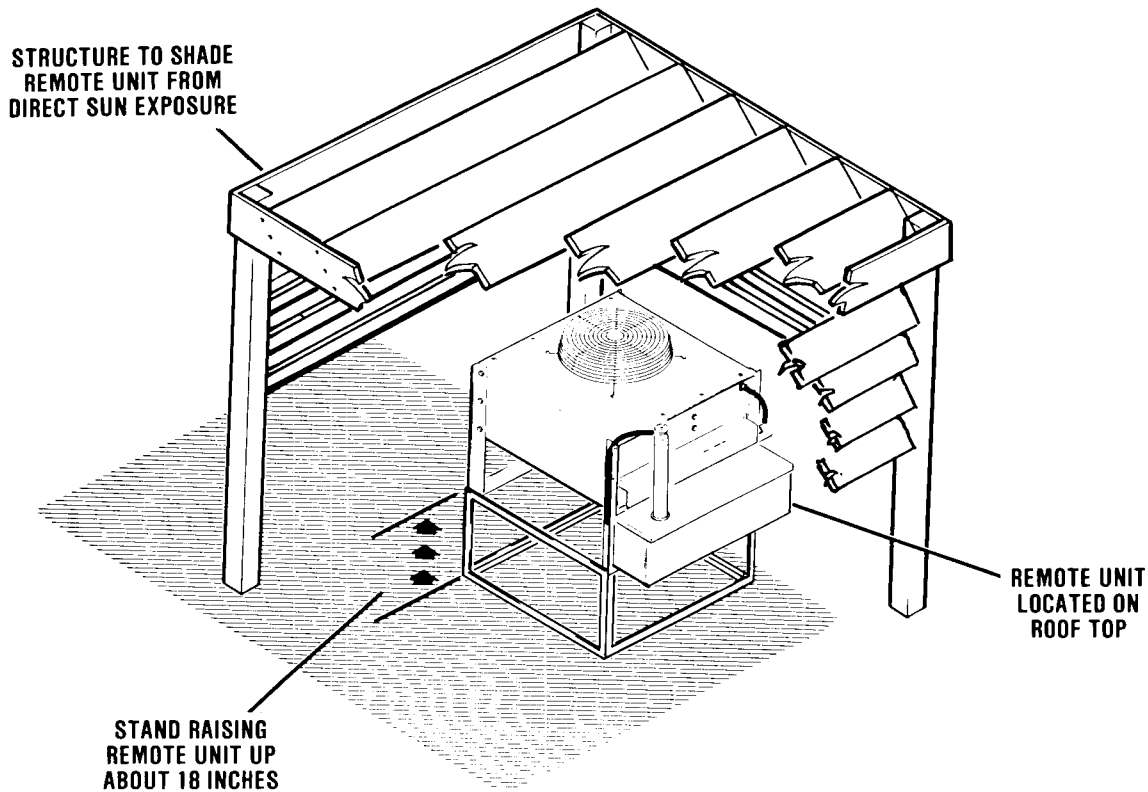

*Warm Climate Performance Improvements used only when
RCLS air intake temperature is greater than the roof air temperature.*

1. Route connecting plumbing, avoiding traps and maintaining 1/8-inch per foot pitch drain toward icemaker(s) with the Manifold and Drain Valve at the lowest point of the plumbing system. Insulate all exposed tubing separately using cellular foam pipe insulation.
2. Route tubing between manifold connections and ice machine water-cooled condenser inlet and condenser drain. Locate the Manifold Assembly low enough in the interconnecting tubing so that complete drainage of the system is possible.

WARNING

To prevent damage to plastic pump casing, wrap outlet tubing inside and outside of the remote unit cabinet with wet cloth, **BEFORE** soldering outlet joints.

CAUTION

Use of smaller diameter tubing severely restricts coolant flow and ultimately ice production.

**RCLS
B MODEL**

**REMOTE CLOSED LOOP SYSTEM
GENERAL INFORMATION AND INSTALLATION**

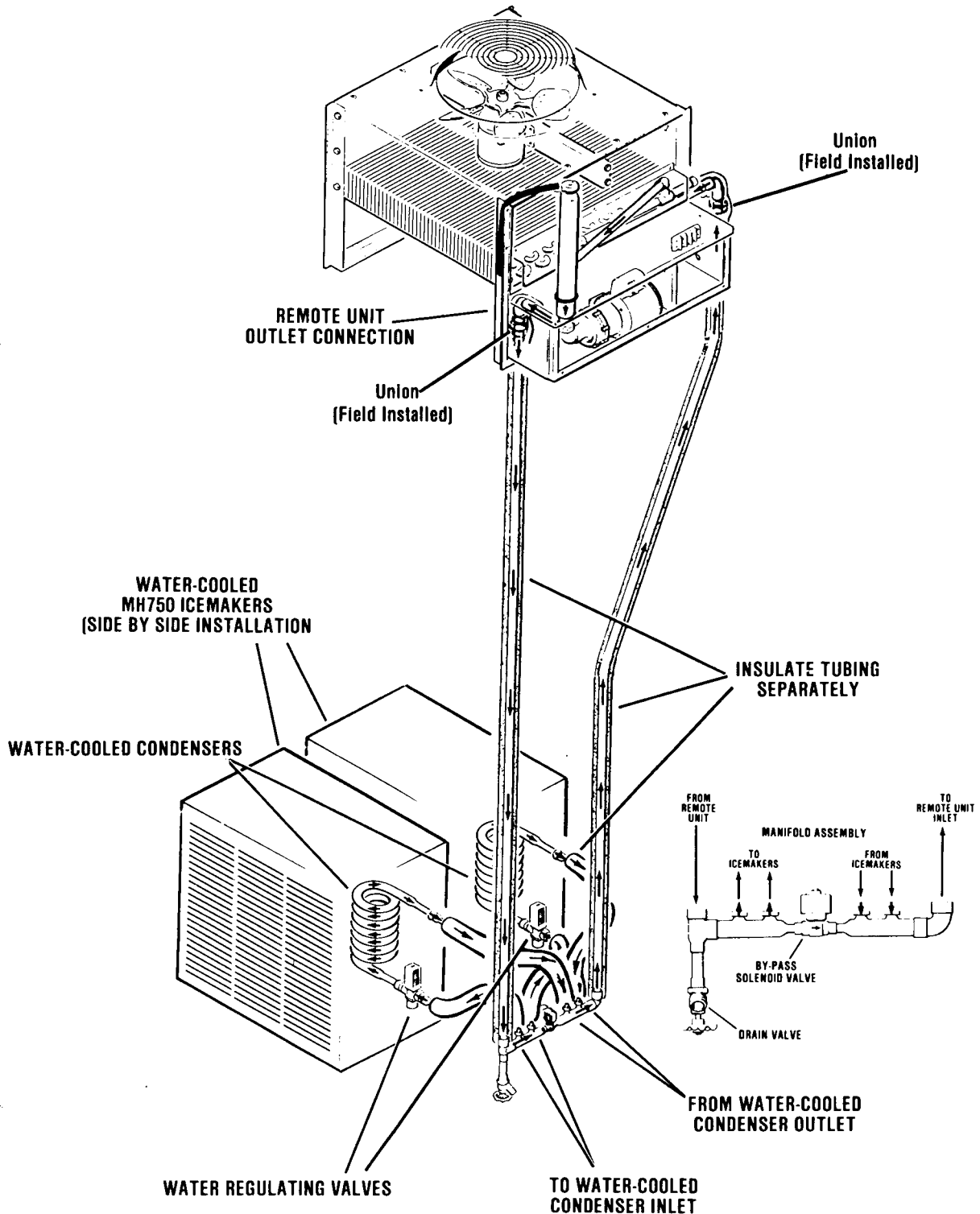

Interconnecting Tubing and Manifold Connections, Two MH750 Nugget Ice makers

**REMOTE CLOSED LOOP SYSTEM
GENERAL INFORMATION AND INSTALLATION**

**RCLS
B MODEL**

NOTE: The manifold must be installed so that the coolant flow is in the direction of the arrow on the solenoid valve.

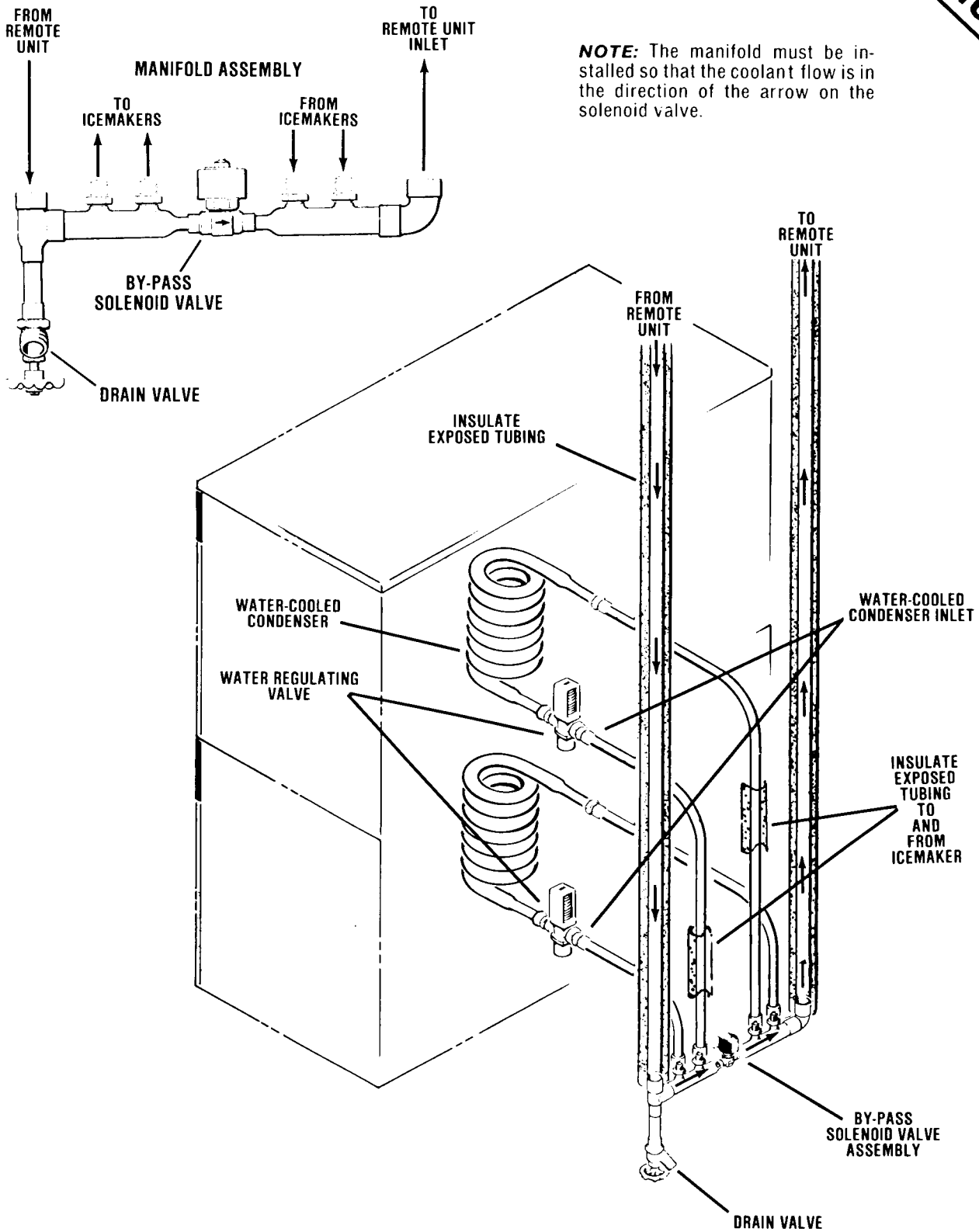

Interconnecting Tubing and Manifold Connections. Stacking Modular Cubers.

REMOTE CLOSED LOOP SYSTEM GENERAL INFORMATION AND INSTALLATION

V. ELECTRICAL CONNECTIONS

SEE NAMEPLATE for current requirements to determine wire size to be used for electrical hookup. The remote condenser requires a solid earth ground wire. See wiring diagram. Be certain the remote condenser is connected to its own electrical circuit and individually fused. The maximum allowable voltage variation should not exceed ten percent of the nameplate rating, even under starting conditions.

Low voltages can cause erratic operation and may be responsible for serious damage.

All external wiring should conform to the National, State and local electrical code requirements. Usually an electrical permit and services of a licensed electrician will be required.

SOLENOID BY-PASS VALVE

The By-Pass Valve is operated by a electromagnetic coil which is a dual voltage coil that operates at either 115 volts or 230 volts. This is compatible with most Scotsman icemakers used in RCLS installations.

FOR SINGLE ICEMAKER HOOK-UP

1. Connect icemaker and remote unit to separate electrical power sources.
2. Refer to wiring diagram supplied with the icemaker and locate contactor terminals connected to the compressor. Connect lead wires from the By-Pass Valve Solenoid to the compressor terminal contactor connections, commonly T1 and T2. Bypass valve coil must be wired to match the icemaker voltage.

NOTE

Scotsman contour cuber CM1200-31 connections are made at terminals T2 of the compressor contactor and terminal 5 of the potential relay.

NOTE

When two icemakers are installed, a Stacking Kit must be used in conjunction with the Solenoid By-Pass Valve.

KRCL STACKING KIT

Dual icemaker installation in the Remote Closed Loop System requires use of a Stacking Kit.

KRCL115: For use with (2) 115 volt icemakers.

KRCL230: For use with (2) 230 volt icemakers.

FOR CONNECTION OF TWO ICEMAKERS:

See stacking kit NAMEPLATE and verify voltages are compatible with ice machines. Refer to

appropriate wiring diagrams and connect each icemaker to the Stacking Kit terminal strip as follows:

1. Attach the Stacking Kit to a permanent location, convenient for each icemaker hook up and future service. Attach a solid earth ground wire to the GROUND SCREW.
2. Route connecting wires from first ice machine compressor contactor terminals, commonly T1 and T2, and connect to Stacking Kit terminal strip connections marked: FROM FIRST ICE MACHINE.
3. Route connecting wires from second ice machine compressor contactor terminals, commonly T1 and T2 and connect to Stacking Kit terminal strip connections marked: FROM SECOND ICE MACHINE.
4. Route connecting wires from Solenoid By-Pass Valve leads to the Stacking Kit terminal strips and connect to the connections marked: TO VALVE. Solenoid valve coil must be wired to match icemaker voltage.

CAUTION

IMPROPER VOLTAGE SUPPLIED TO THE ICEMAKER WILL VOID YOUR PARTS REPLACEMENT PROGRAM.

VI. FINAL CHECK LIST:

1. Has 1-inch copper tubing been used to interconnect components? Drain at lowest point?
2. All shipping material removed?
3. Have all electrical and plumbing connections been completed?
4. Have remote unit circulating pump and fan been checked for proper operation?
5. Proper air flow ventilation through remote unit?
6. Has proper SCOTFREEZE coolant been added and checked for proper level. Leak checked.
7. Thoroughly explain to the owner/user the significant specifications of the RCLS start up and operation maintenance & cleaning instructions going through the procedures.
8. Answer all questions about the RCLS, by the owner. Inform the owner of the name and telephone number of the authorized SCOTSMAN Service Agency serving him.

OPERATING INSTRUCTIONS

PRE-START

1. Fill system with distilled water and operate circulating pump. This action will rinse the system of flux or other contaminants. With circulating pump operating, check tubing connections for leaks.
2. Drain rinsing water from the system at the drain valve. Keep track of quantity of liquid used to fill the system. This information will be helpful when filling the system with coolant.
3. Refill system with the proper coolant. Do not dilute coolant. Use of any other coolant will void warranty.
4. Operate system several hours and **recheck coolant level**. Coolant foams and expands during initial filling and coolant contracts as air is purged during use.
5. To eliminate accidental drainage of coolant, remove handle from drain valve and store in an accessible location.

| IMPORTANT | |
|--|------------------------------|
| THE FOLLOWING HEAT TRANSFER FLUID MUST BE USED FOR PROPER OPERATION AND FREEZE PROTECTION | |
| LOWEST OUTDOOR TEMPERATURE EXPECTED | HEAT TRANSFER FLUID REQUIRED |
| + 32° F | DISTILLED WATER |
| + 10° F | UNDILUTED SCOTFREEZE K RED |
| - 30° F | UNDILUTED SCOTFREEZE K BLUE |
| FAILURE TO USE THE RECOMMENDED HEAT TRANSFER FLUID WILL VOID THE SCOTSMAN WARRANTY 17-1567-01 | |

WARNING

This system must be filled with proper coolant. See the chart to determine the correct coolant. Use of any other coolant will void warranty.

WARNING

DO NOT DILUTE THE SCOTFREEZE KRED OR KBLUE.

WARNING

Running the unit without coolant will damage the pump.

START UP / OPERATION

WARNING

Check coolant level before START-UP. Running the unit without coolant will damage the pump.

I. START UP

1. Move the main power source ON-OFF switch to the remote unit to the ON position supplying electrical power to the Remote Unit. Observe the Remote unit fan motor and pump motor OPERATE and coolant CIRCULATES.
2. Move the main power source ON-OFF switch to each icemaker to the ON position supplying electrical power to each icemaker.
3. Observe that the By-Pass Solenoid has CLOSED diverting coolant flow through the icemaker condenser where heat generated during the icemaking process is transferred to the RCLS coolant.
4. Observe that the ice harvest is normal in quality and production is satisfactory.
5. Let the system operate until ice covers the bottom of the bin. Check for any excess noises beyond normal:

REMOTE UNIT

- a. Fan noises, blades bent, touch other surfaces or out-of-balance.
- b. Vibrating type, pump loose at hold down bolts.

ICEMAKER:

- a. Abnormal ice production noises.

6. FLAKERS: Hold a handful of ice around the Ice Storage Bin Thermostat Control Bulb to test icemaker when the compressor shuts off. The By-Pass Solenoid Valve will OPEN and the coolant will circulate within the interconnecting tubing and the remote unit.
7. Operate system for 30 minutes. Observe ice production is normal. Look and listen for unusual noise, vibrations or leakage. Stop icemaking process. Remove the ice and rinse the storage bin. Re-start automatic icemaking process.
8. Check coolant level and condition every 6 months. Coolant level must be above mid point of the remote condenser surge pipe. Do not replenish with water. Refill with proper coolant. To test coolant condition, use DOWFROST INHIBITED PROPYLENE GLYCOL TEST KIT following instructions provided with the test kit. Test Kit available through the Scotsman Service Department.
9. Refer to Maintenance and Cleaning Instructions and observe maintenance guidelines.

REMOTE CLOSED LOOP SYSTEM

PRINCIPLES OF OPERATION

RCLS "A" and RCLS "B" models are similar in appearance although RCLS "A" model does not operate the same as RCLS "B" model. Refer to RCLS "A" model Installation Instructions for RCLS "A" model information. Additional Service Parts and wiring details may be found at the back of this book for the RCLS "A" model.

INTRODUCTION

The following text describes the sequential events as the coolant circulates within the Remote Closed Loop System.

I. ICEMAKER

Heat collected during the icemaking process is transferred from the refrigerant to the Scot Freeze coolant inside the icemaker water cooled condenser coil.

II. REMOTE UNIT

The circulating pump operates continually, circulating the coolant within the Remote Closed Loop System. Heat is transferred to the SCOTFREEZE coolant at the icemaker condenser coil and moved through the interconnecting tubing to the Remote Unit. Air drawn across the coils of the remote unit by the fan removes heat from the SCOTFREEZE coolant. The lowered temperature SCOTFREEZE coolant recirculates through the interconnecting tubing and returns to the icemaker.

When the ice storage bin is full, the ice machine(s) will shut off, the By-Pass Valve OPENS and coolant flow is diverted from the icemaker and circulates within the interconnecting tubing and the remote unit. When the automatic icemaking process restarts, the solenoid operates CLOSING the By-Pass Valve and the coolant flows through the ice machine water regulating valve and the water cooled condenser coil.

III. ELECTRICAL

The Remote Closed Loop System has two separate electrical circuits:

The remote unit electrical power supply which supplies power to the remote unit circulating pump and fan motor. Both run continuously whenever the main power supply switch to the Remote Unit is ON.

The second electrical circuit is between the icemaker and the By-Pass Valve Solenoid.

The By-Pass Valve Solenoid is electrically connected to the icemaker compressor leads. Electrical power supplied to the icemaker compressor is also supplied to the By-Pass Valve Solenoid which operates and CLOSES the By-Pass Valve.

IV. KRCL STACKING KIT

When two ice machines are connected to the RCLS electrical system, the Solenoid By-Pass Valve must be connected to the ice machines through the Stacking Kit KRCL. Electrical current from the first ice machine compressor contacts supplies current to the Stacking Kit relay coil which switches the two N/O contacts to the CLOSED position completing the circuit to the Solenoid By-Pass Valve. When current is supplied from the second ice machine the relay contacts are in the N/C position, the circuit is complete and the relay coil is not energized. When no ice machine is supplying current to the Solenoid By-Pass Valve, the Valve is in the Normally OPEN position and the coolant flow is through the normally OPEN By-Pass Valve.

**RCLS
B MODEL**

**REMOTE CLOSED LOOP SYSTEM
PRINCIPLES OF OPERATION**

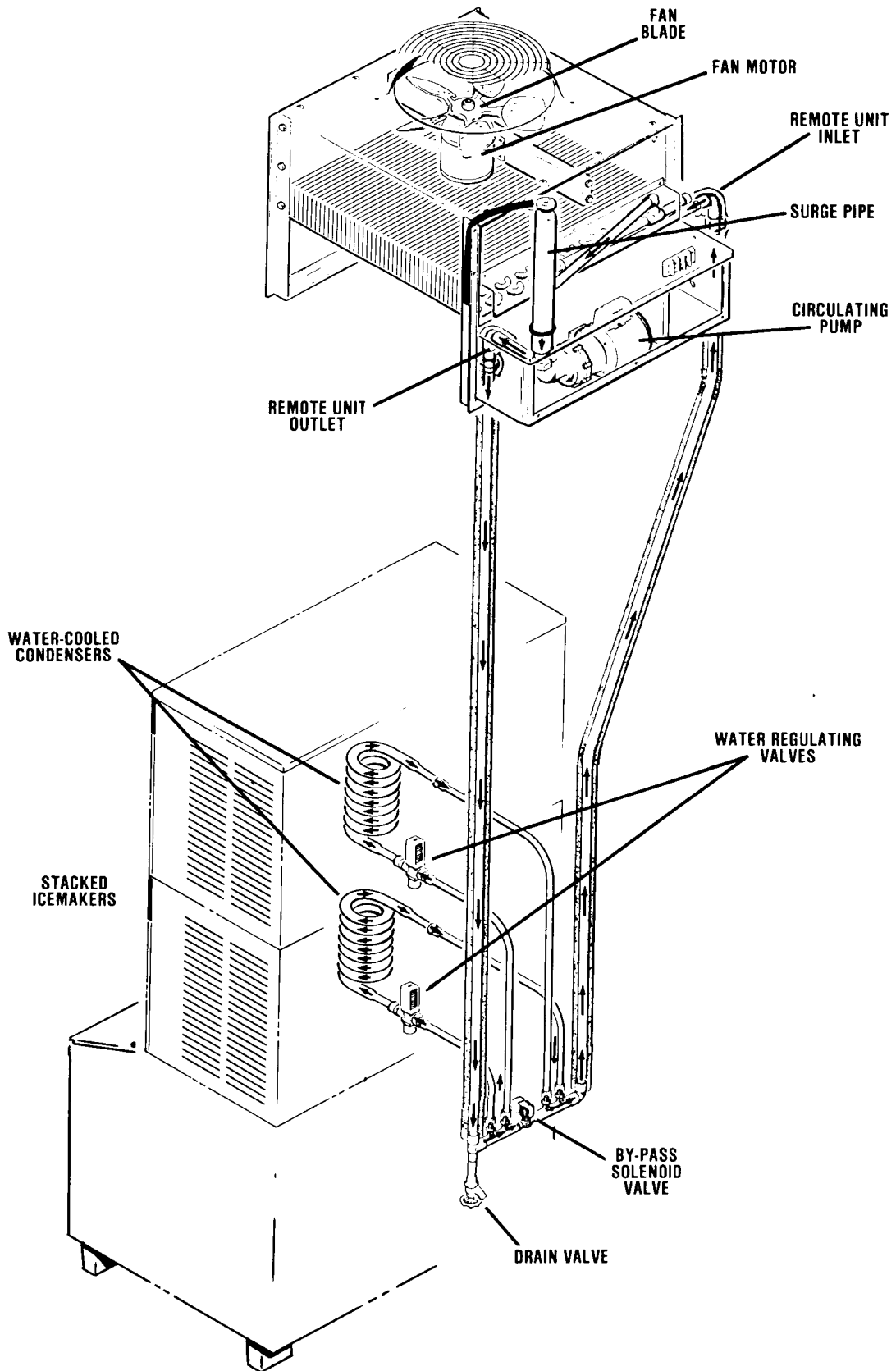

Cooling Cycle.

ADJUSTMENT, REMOVAL AND REPLACEMENT

Read the instructions thoroughly before performing any Adjustment, Removal or Replacement Procedures.

NOTE

Any work on the remote condenser or by-pass solenoid will require that the connected ice-maker(s) be shut OFF first.

I. CIRCULATING PUMP ASSEMBLY

To remove Circulating Pump and Motor Assembly:

1. Switch electrical power supply to icemaker to OFF disconnecting power.
2. Switch electrical power supply to remote condenser to OFF disconnecting power to remote condenser.

WARNING

Always DISCONNECT Electrical power supply BEFORE STARTING any Removal procedures to prevent personal injury or damage to equipment.

3. Disconnect electrical leads to pump motor.
4. Open drain plug at the lowest point of the interconnecting tubing and drain sufficient coolant from the system. Surge pipe cap may have to be removed to relieve pressure. Coolant may be saved for reuse provided extreme operating conditions have not deteriorated the coolant condition.
5. Uncouple pipe fittings between surge pipe and pump. Also uncouple the outlet pipe fitting from the pump.
6. Remove pump and motor mounting bolts, and remove pump and motor assembly from the chassis.

Test coolant condition before reusing.

To replace the pump and motor assembly reverse the removal procedures.

II. FAN BLADE & FAN MOTOR

To remove remote condenser Fan Blade and Fan Motor:

1. Switch electrical power supply to icemaker to OFF disconnecting power.

2. Switch electrical power supply to remote unit to OFF, disconnecting electrical power to remote unit.

WARNING

Always DISCONNECT Electrical power supply BEFORE STARTING any Removal procedures to prevent personal injury or damage to equipment.

3. Remove screws and condenser fan guard.
4. Remove set screw and remove fan blade from motor shaft.
5. Remove electrical leads to the fan motor.
6. Remove motor mounting bolts and remove fan motor.

To replace Fan Blade and Fan Motor reverse the removal procedures.

III. BY-PASS VALVE AND SOLENOID ASSEMBLY

To remove By-Pass Valve and Solenoid assembly.

1. Disconnect electrical power supply to the icemaker.
2. Switch electrical power supply to remote unit to OFF, disconnecting electrical power to remote unit.

WARNING

Always DISCONNECT Electrical power supply BEFORE STARTING any Removal procedures to prevent personal injury or damage to equipment.

3. Disconnect electrical leads to By-Pass Solenoid.
4. Open drain valve at the manifold of the interconnecting tubing and drain all coolant from system. Surge pipe cap may have to be removed to relieve pressure. Coolant may be saved for reuse provided extreme operating conditions have not deteriorated condition.
5. Unsweat fittings and remove By-Pass Valve and Solenoid assembly.

Test coolant condition before reusing.

To replace the By-Pass Valve and Solenoid assembly reverse the removal procedures.

REMOTE CLOSED LOOP SYSTEM

MAINTENANCE & CLEANING INSTRUCTIONS

I. GENERAL

The periods and procedures for maintenance and cleaning are given as guides and are not to be construed as absolute or invariable. Cleaning especially will vary, depending upon the volume of ice produced and extreme ambient temperatures. Icemaker must be maintained individually, in accordance with its own particular location requirements.

II. ICEMAKER

Clean icemaker per cleaning instructions furnished with the particular unit.

III. REMOTE UNIT

Frequent cleaning and inspection of the Remote Condenser should be performed to maintain maximum efficiency of icemaker. A dirty Condenser or blocked air flow will greatly decrease icemaking efficiency.

1. With electrical power OFF, to both the icemaker and the Remote Condenser, clean the Remote Condenser, using a vacuum cleaner, whisk broom or brush. DO NOT

USE A WIRE BRUSH. Instruct customer to clean frequently.

2. Check that fan blades move freely, are not touching any surfaces, are not bent or out of balance; check that the wire guard is properly installed and securely attached.
3. Check that the roof area immediately surrounding Remote Condenser is free and clear of any debris that may collect, such as leaves, paper, trash, etc.
4. Check coolant level and condition every 6 months. Coolant level must be above mid point of the remote condenser surge pipe. Replenish with the proper coolant. Refill with proper SCOTFREEZE KRED or KBLUE pre-mixed coolant. To test coolant condition, use DOWFROST INHIBITED PROPYLENE GLYCOL TEST KIT following instructions provided with the test kit. Test Kit available through the Scotsman Service Department.

IMPORTANT

THE FOLLOWING HEAT TRANSFER FLUID MUST BE USED FOR PROPER OPERATION AND FREEZE PROTECTION

| LOWEST OUTDOOR TEMPERATURE EXPECTED | HEAT TRANSFER FLUID REQUIRED |
|-------------------------------------|------------------------------|
| + 32° F | DISTILLED WATER |
| + 10° F | UNDILUTED SCOTFREEZE K RED |
| - 30° F | UNDILUTED SCOTFREEZE K BLUE |

FAILURE TO USE THE RECOMMENDED HEAT TRANSFER FLUID WILL VOID THE SCOTSMAN WARRANTY

17-1567-01

WARNING

This system must be filled with proper coolant. Use of any other coolant will void warranty.

WARNING

Running the unit without coolant will damage the pump.

IV. Sanitizing instructions:

The coolant may restrict the system if it becomes thickened, or "jells". This is usually caused by something "growing" in the system, and the glycol system should be sanitized.

A possible sanitizer is **CALGON** ice machine sanitizer. To sanitize:

1. Turn off icemakers and RCLS.
2. Drain the glycol system, discard the glycol.
3. Mix the sanitizer only with **distilled water** according to the sanitizer manufacturer's directions and fill the RCLS system.
4. Run the RCLS and the icemakers for about 10 - 15 minutes, then turn off the RCLS and icemakers, drain the system, discard the sanitizing solution.
5. Refill the system with new, fresh coolant.
6. Start up and check the system for leaks and operation.

SECTION VI SERVICE DIAGNOSIS

The Service Diagnosis Section is for use in aiding the serviceman in diagnosing a particular problem or pin-pointing the problem area.

The following chart lists corrective actions for the causes of known symptoms of certain problems that can occur in the Remote Closed Loop System.

| SYMPTOM | POSSIBLE CAUSE | CORRECTION |
|--|--|---|
| Poor Ice Production | Coolant Level Insufficient | Add SCOTFREEZE. Look for a leak. |
| | Dirty Remote Condenser | Remove debris from remote condenser fins — restore air circulation. |
| | Extreme high ambient temperatures | Shade Remote Condenser from direct sunlight. DO NOT BLOCK AIR CIRCULATION |
| | Icemaker requires maintenance | Service Icemaker |
| | Circulating Pump | Replace Pump Assembly |
| | Improper tubing size or length | Replace and reroute as required |
| Wrong coolant used | Wrong coolant used | Flush with distilled water and replace with proper coolant. See Freeze Protection Chart. |
| | Coolant contaminated | Flush and Sanitize, See Cleaning. |
| | | |
| No Ice Production | Main power supply to remote condenser or icemaker OFF. | Reset circuit breaker or replace fuse system for shorts or abnormally high current drain. |
| | Dirty Remote Condenser | Remove debris from remote condenser fins — restore air circulation. |
| | Solenoid By-Pass Valve defective | Replace Solenoid By-Pass Valve Assembly |
| | Stack Kit Relay defective | Replace Stack Kit Relay. |
| | Coolant level insufficient | Find leak, repair, add proper coolant. |
| | Circulating Pump defective | Replace Pump Assembly. |
| Fan Motor defective | Fan Motor defective | Replace Fan Motor Assembly. |
| | | |
| High icemaker discharge pressure, with no ice maker malfunction such as non-condensable gases or defective water regulating valve | Normal when the RCLS air intake temperature goes past a certain point (different for each installation, but usually 70 - 80° F.) | None required — optional steps listed below. |

OPTIONAL STEPS FOR OPTIMUM ICE MAKER PERFORMANCE:

The RCLS effectively "converts" water cooled ice-makers to air cooled remote types and as in any air cooled refrigeration unit, when the cooling air temperature goes up, performance suffers. The following are steps to take to try and boost performance.

1. Check the installation. Restrictive piping, or excessively hot intake air, will cause performance drops — see Installation Instructions, pages 3 - 5.

2. If RCLS power supply is 208v, and pump motor is rated 230v, boost it to 230v using a transformer.
3. Eliminate all tubing restrictions inside the ice machine cabinet: route 1/2" tubing from by-pass manifold directly to the water regulating valve, and route 1/2" tubing from ice maker condenser outlet to by pass manifold.
4. Change water regulating valves to 1/2" type.

**RCLS
B MODEL
ONLY**

Remote Closed Loop System

WIRING DIAGRAM

**THIS UNIT MUST
BE GROUNDED**

KRCL CONTROL BOX

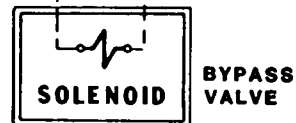
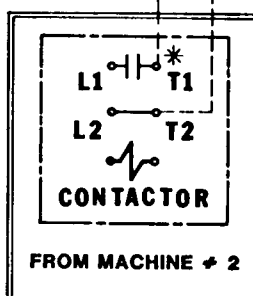
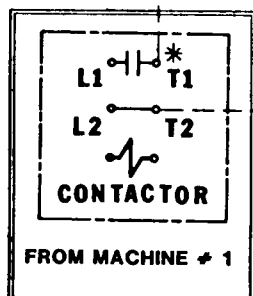
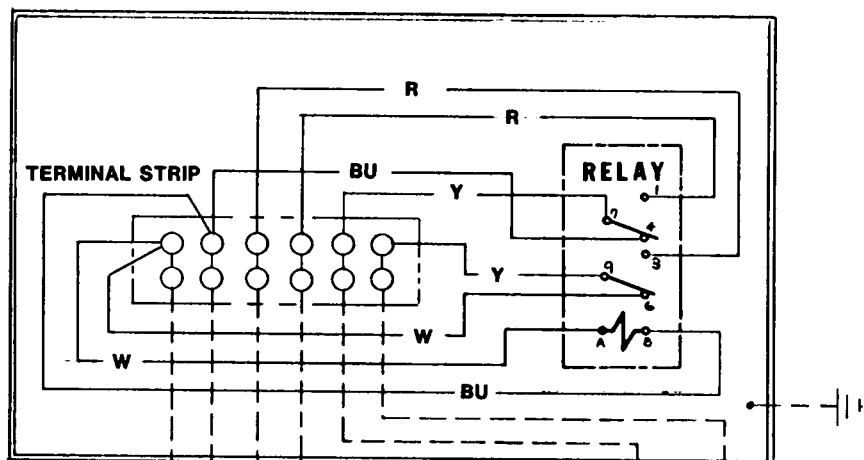

NOTE: CM1200-31
MODELS ONLY**
CONNECT TO TERMINAL 5 OF
THE POTENTIAL RELAY
INSTEAD OF TERMINAL T1
ON THE CONTACTOR

CAUTION:

BOTH MACHINES MUST HAVE SAME VOLTAGE RATING

A30554-001

PARTS ILLUSTRATIONS AND PARTS LISTS

I. GENERAL

This section contains the Parts Illustrations and the Parts List for each of the major assemblies in the Model RCLS15 and RCLS30 Remote Closed Loop Systems.

A *No Number* designation, when used in the Part Number Column indicates the unit is not available from SCOTSMAN as an assembly. This designation is used only for the convenience and clarity of division in cataloging.

II. HOW TO ORDER PARTS OR ASSEMBLIES

When ordering parts or assemblies, to avoid costly delays and errors in shipment, give the part number, the complete description shown in the list, and the quantities of each part or assembly required. Also include the Model name, the serial number of the unit for which the part is required, and for parts which require color matching, the color of the Cabinet.

III. DESCRIPTION

A. All Part Numbers have TEN DIGITS (spaces), required for use in the Computer System. BE

SURE to fill in ALL SPACES in the CATALOG NUMBER column, on the Parts Order form.

B. Enter the QUANTITY of the Parts ordered, in the last digit column under the QUANTITY column heading, the one under the small 55 number, for parts from 1 thru 9. For 10 or more parts use two columns.

To be sure you receive the proper parts in the proper quantities, ALWAYS use the PART NUMBERS and DESCRIPTIONS given in the Parts Manuals.

Write an order for the Part. (Use SCOTSMAN Parts Order Form DN103). Be sure to include:

- a. Distributor Name.
- b. (Use for DROP-SHIP order ONLY.)
- c. Distributor Purchase Order Number.
- d. Carrier.
- e. How shipped (Truck, Rail, UPS, etc.)
- f. Date ordered.
- g. Part Catalog Number. (Use full TEN digits (spaces) listed in Parts Manual, including dashes between numbers.)
- h. Description — as listed in Parts Manual.
- i. Quantity — number of parts ordered. (Use far right column.)

B MODEL
See Pages 19, 20 & 21 for
A MODEL

**REMOTE CLOSED LOOP SYSTEM
THE PARTS ILLUSTRATIONS AND PARTS LISTS**

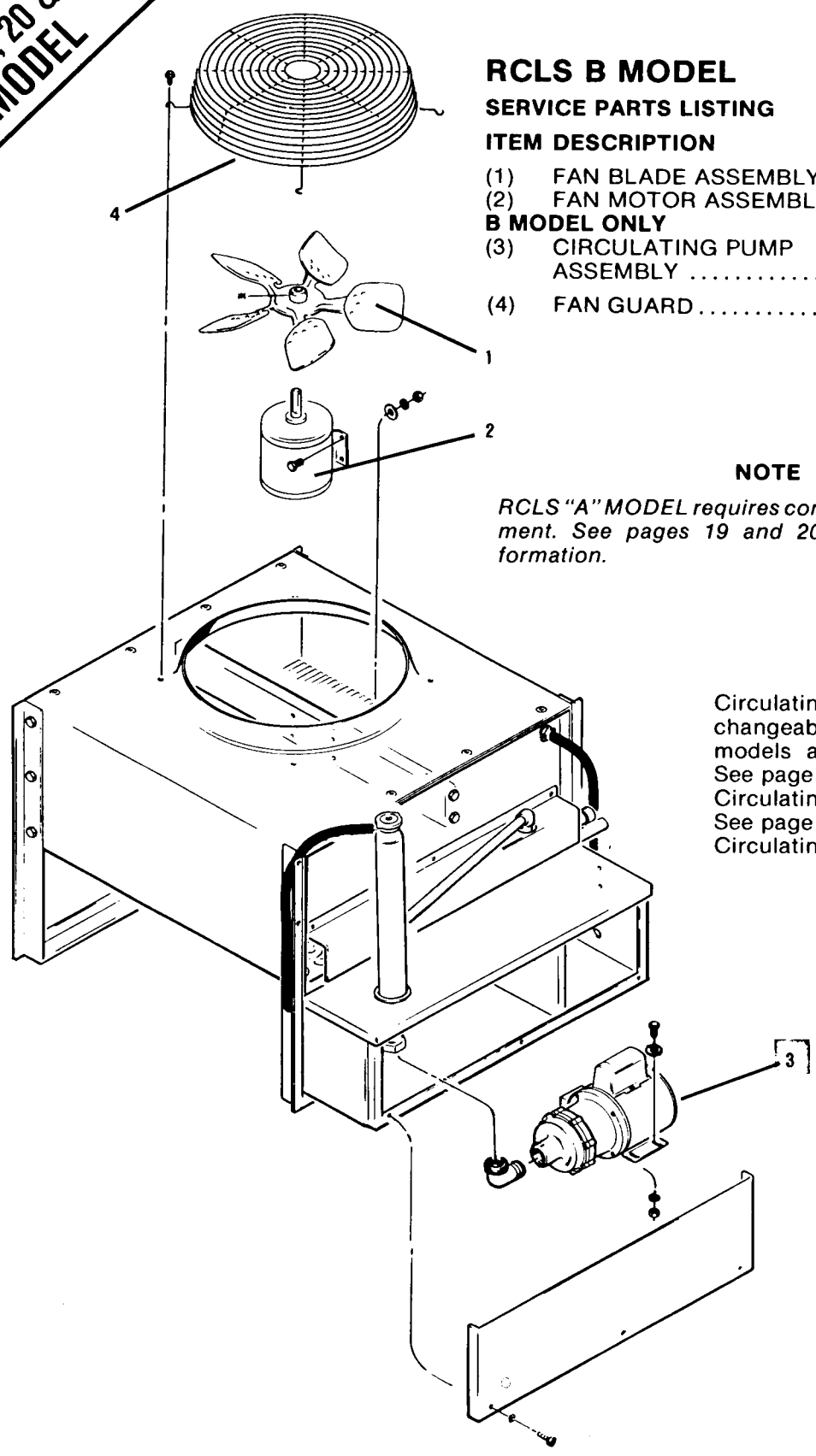

RCLS B MODEL

SERVICE PARTS LISTING

| ITEM DESCRIPTION | PART NO. |
|-------------------------------------|-------------|
| (1) FAN BLADE ASSEMBLY..... | 18-5104-01 |
| (2) FAN MOTOR ASSEMBLY..... | 18-5301-01 |
| B MODEL ONLY | |
| (3) CIRCULATING PUMP ASSEMBLY | See Page 18 |
| (4) FAN GUARD..... | 02-2618-01 |

NOTE

RCLS "A" MODEL requires complete pump replacement. See pages 19 and 20 for "A" Model information.

Circulating pump is **NOT** interchangeable between RCLSA models and RCLSB models. See page 18 for RCLSB model Circulating Pump Assembly. See page 21 for RCLSA model Circulating Pump Assembly.

RCLS Major Assembly

**REMOTE CLOSED LOOP SYSTEM
THE PARTS ILLUSTRATIONS AND PARTS LISTS**

B MODEL
See Page 19, 20 & 21 for
A MODEL

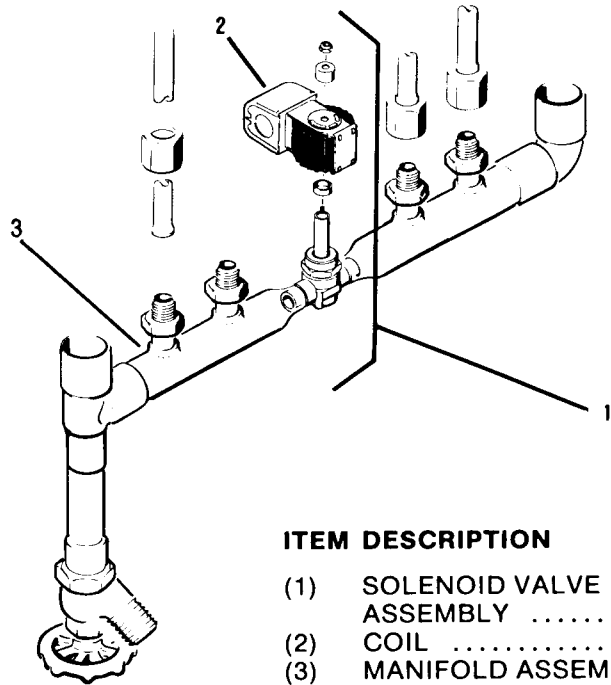

| ITEM | DESCRIPTION | PART NO. |
|------|-------------------------------|------------|
| (1) | SOLENOID VALVE ASSEMBLY | 12-2246-01 |
| (2) | COIL | 12-2246-11 |
| (3) | MANIFOLD ASSEMBLY | A30546-020 |

Manifold, By-Pass Valve Assembly.

STACKING KIT

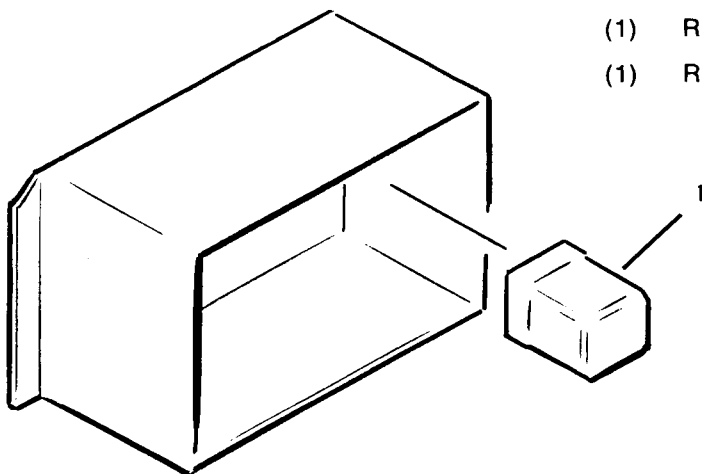

| ITEM | DESCRIPTION | PART NO. |
|------|----------------------|------------|
| (1) | RELAY 115 VOLT | 12-2070-01 |
| (1) | RELAY 230 VOLT | 12-2070-04 |

Stacking Kit Assembly, KRCL115 and KRCL230

B MODEL
See Page 19, 20 & 21 for
A MODEL

**REMOTE CLOSED LOOP SYSTEM
THE PARTS ILLUSTRATIONS AND PARTS LISTS**

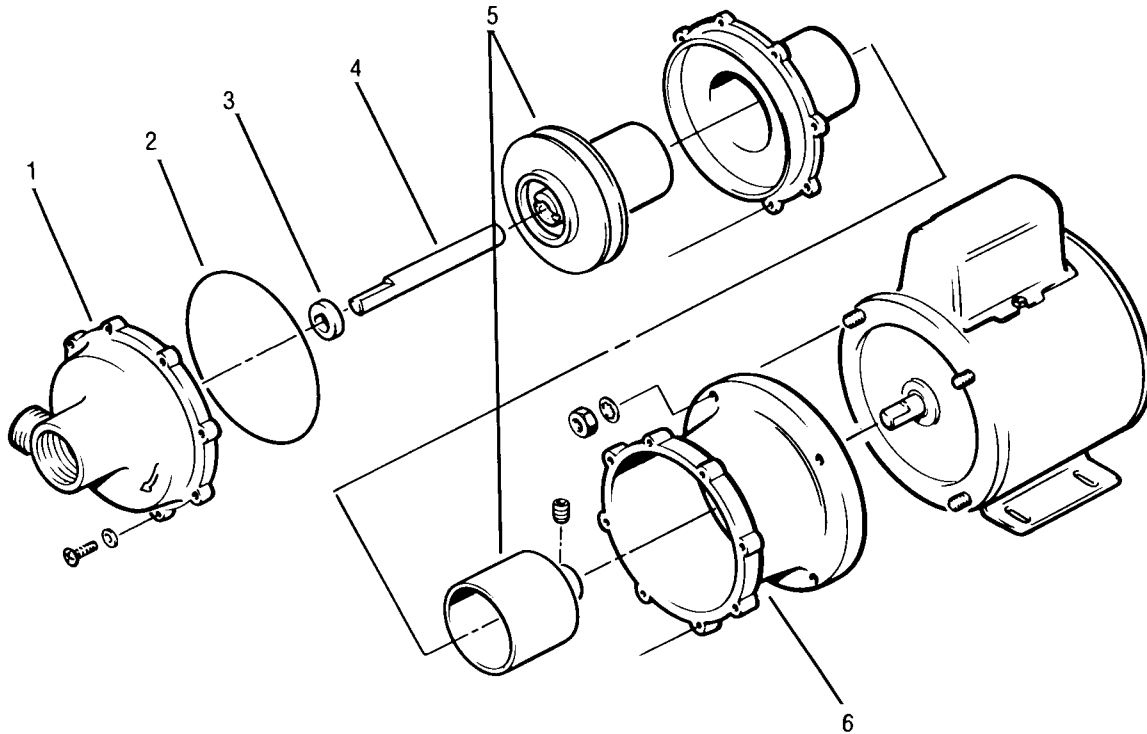

7 COMPLETE PUMP ASSEMBLY
RCLS "B" Pump Assembly
is not interchangeable
with A models.

RCLS "B" PUMP ASSEMBLY

| ITEM | DESCRIPTION | PART NO. |
|------|--|------------|
| (1) | PUMP HOUSING | 12-2245-51 |
| (2) | 4-1/4 x 5/32 THK O RING | 12-2245-52 |
| (3) | CERAMIC THRUST WASHER | 12-2245-54 |
| (4) | IMPELLER SHAFT — CERAMIC | 12-2245-55 |
| (5) | ENCAPS IMPELLER — MAGNET W/CARBON BUSHING | 12-2245-53 |
| (6) | MOTOR CONNECTING BRACKET | 12-2245-50 |
| (7) | COMPLETE PUMP ASSEMBLY | 12-2245-01 |

RCLS "A"
THE PARTS ILLUSTRATIONS AND PARTS LISTS

See Page 16, 17 & 18 for
A MODEL
B MODEL

"A" MODEL ONLY

REMOTE CLOSED LOOP CONDENSER

SURGE PIPE AND COOLANT FILL

SERVICE PARTS LISTING

| | |
|--------------------|------------|
| FAN BLADE ASSEMBLY | 18-5104-01 |
| FAN MOTOR ASSEMBLY | 18-5301-01 |
| CIRCULATING PUMP | 12-2204-01 |
| CONTACTOR | 12-2041-03 |

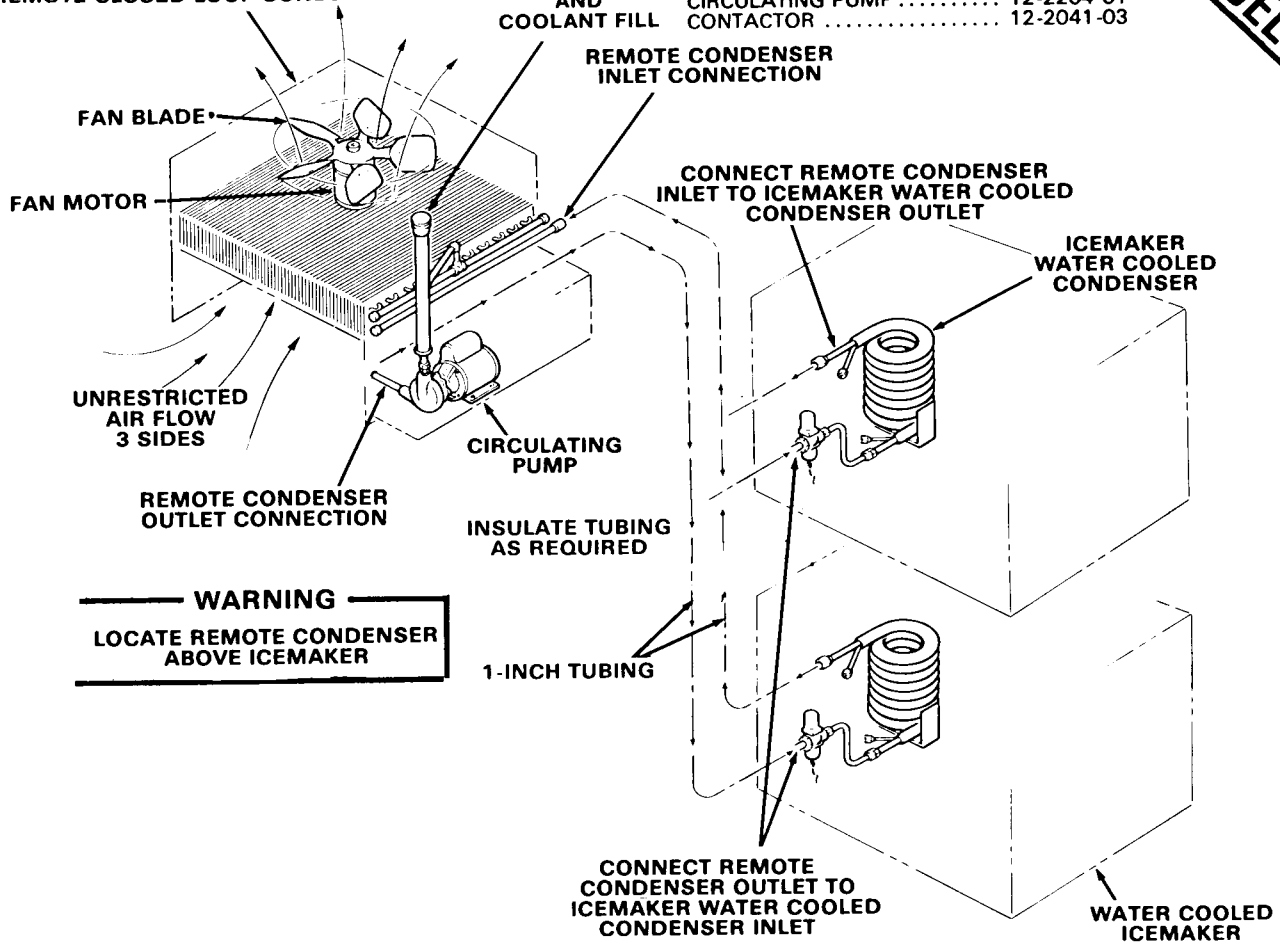

WARNING
LOCATE REMOTE CONDENSER ABOVE ICEMAKER

REMOTE CLOSED LOOP UNIT CONTROL BOX

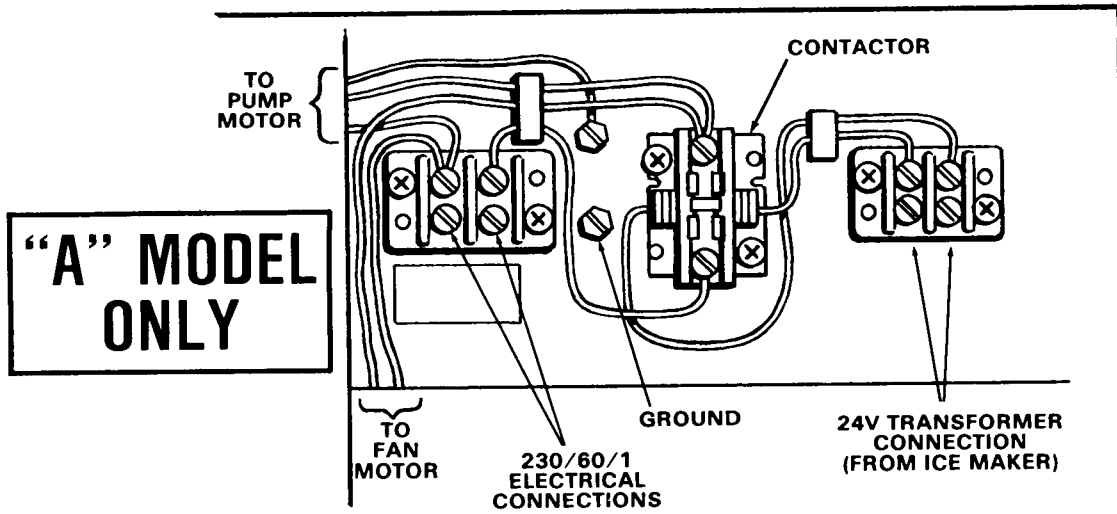

"A" MODEL ONLY

A MODEL ONLY

**RCLS "A"
THE PARTS ILLUSTRATIONS AND PARTS LISTS**

**KIT KTCL1
KIT KTCL2**

WIRING DIAGRAM

**FOR USE WITH
ONE ICEMAKER**

**NOTE
"A" MODEL HOOK-UP
ONLY**

**THIS UNIT MUST
BE GROUNDED**

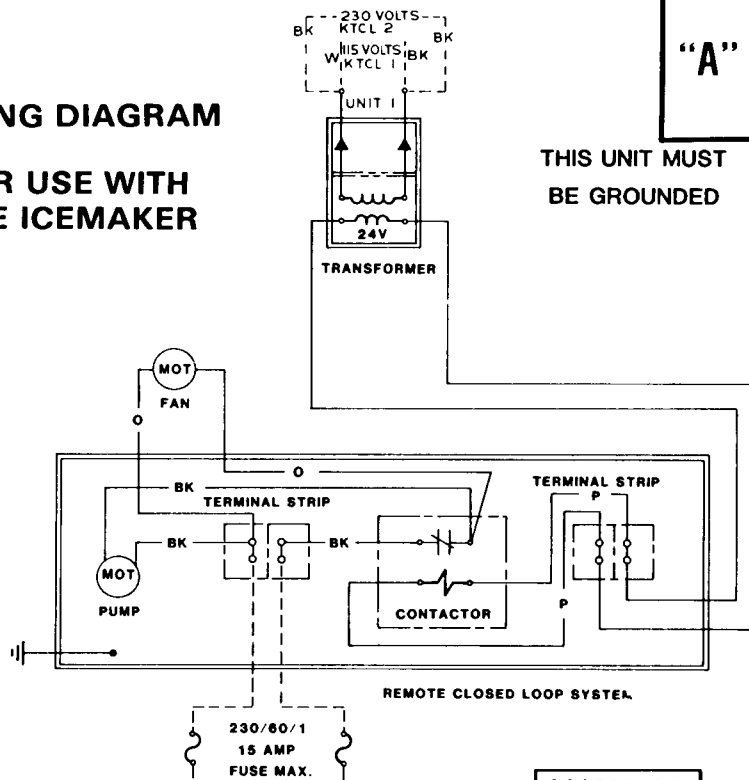

A30303-001

**KIT KTCL3
KIT KTCL4**

WIRING DIAGRAM

**FOR USE WITH
TWO ICEMAKERS**

**NOTE
"A" MODEL HOOK-UP
ONLY**

**THIS UNIT MUST
BE GROUNDED**

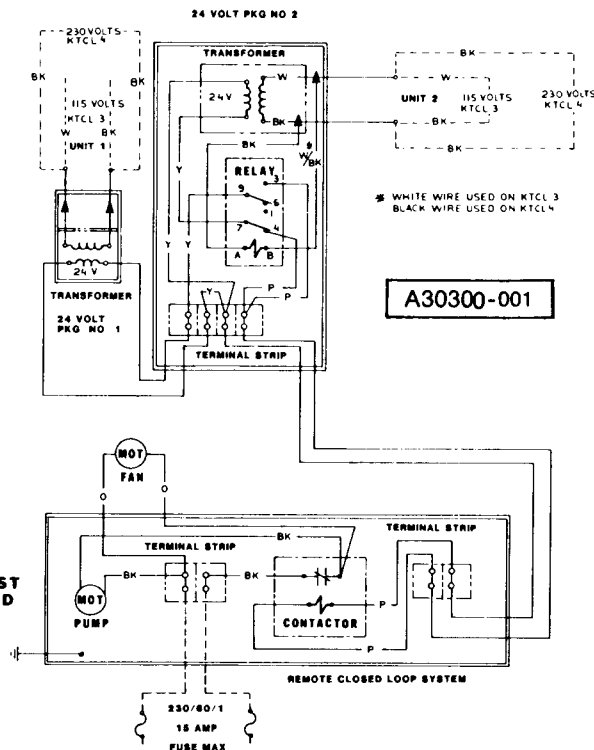

A30300-001

KTCL1, KTCL2, KTCL3, KTCL4 (RCLS "A" Model)

JULY 1984

Page 22

A MODEL
 ONLY

RCLS "A" MODEL PUMP ASSEMBLY

| ITEM | DESCRIPTION | PART NO. |
|------|---|------------|
| (1) | Pump Housing, 3/4-inch threaded Cast Iron | 12-2204-21 |
| (2) | Thrust Washer, Ceramic | 12-2204-22 |
| (3) | Impeller Shaft, 316 Stainless | 12-2204-23 |
| (4) | Impeller Magnet Assembly | 12-2204-24 |
| (5) | Gasket | 12-2204-25 |
| (6) | Housing Connecting Ring | 12-2204-27 |
| (7) | Connecting Bracket | 12-2204-28 |
| (8) | Complete Pump Assembly | 12-2204-01 |

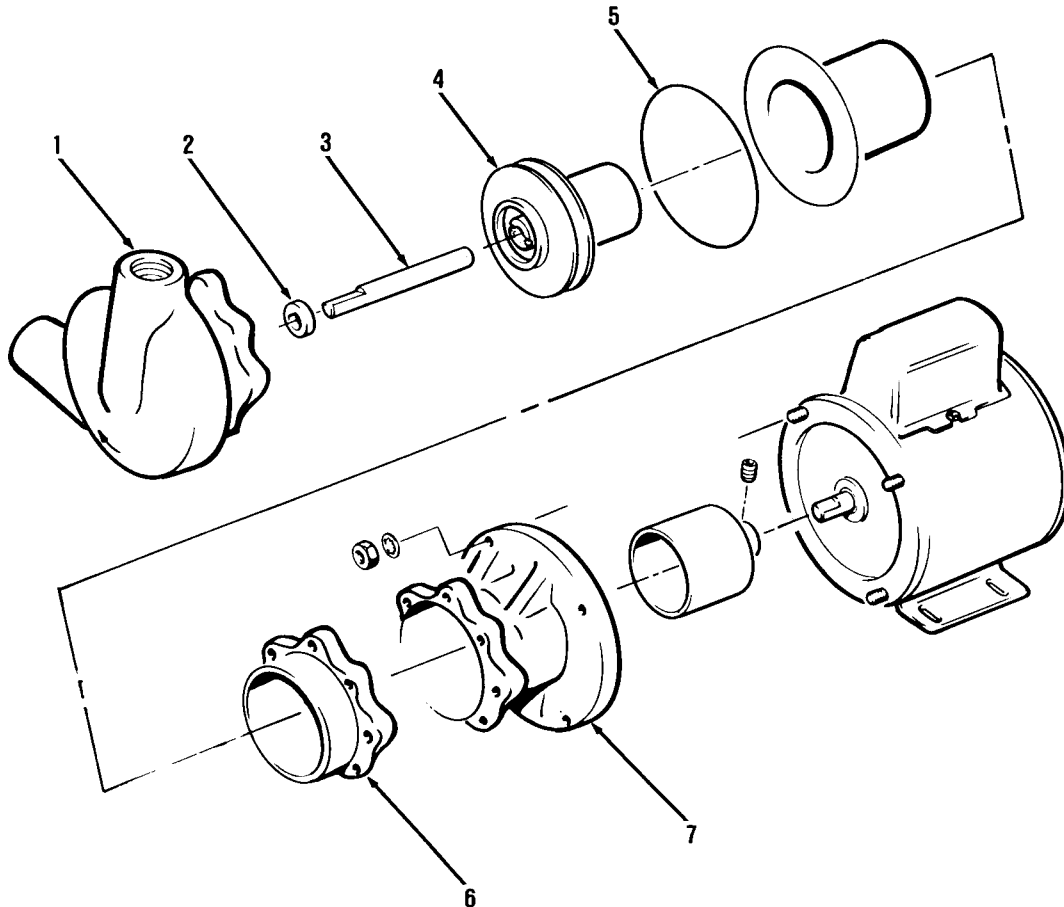

Circulating Pump - RCLS "A"