

FM1200R SERVICE PARTS

This parts list contains the service parts and wiring diagrams for this model. Check the model number in question to be sure that it is applicable to this parts list.

TABLE OF CONTENTS

Cabinet	2
Refrigeration	3
Water	4
Gearmotor.....	5
Evaporator	6
Control Box.....	7
Remote Condenser	8
Wiring Diagrams.....	9

FM1200R SERVICE PARTS

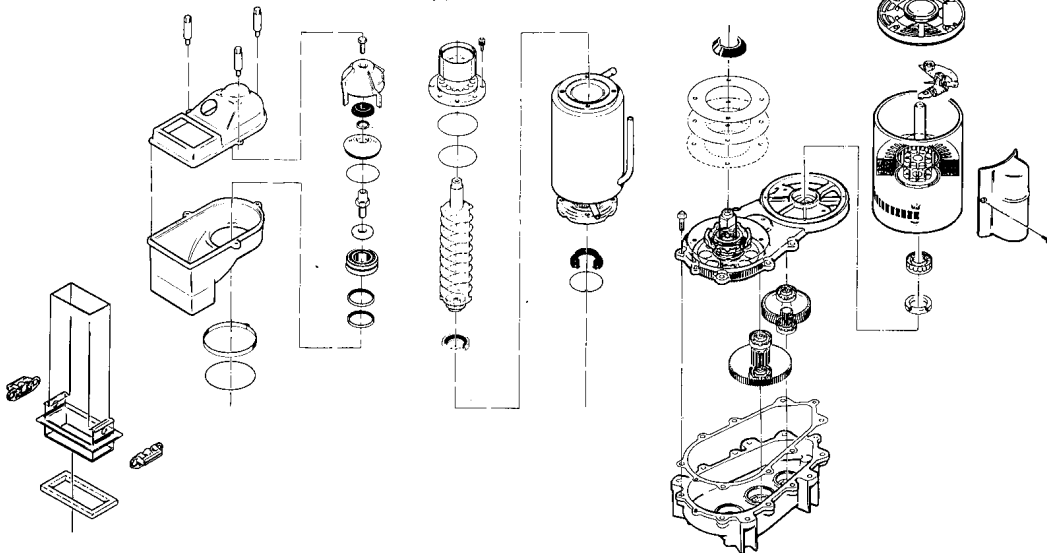
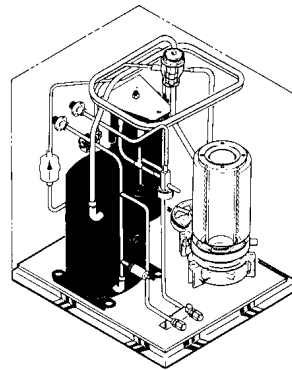
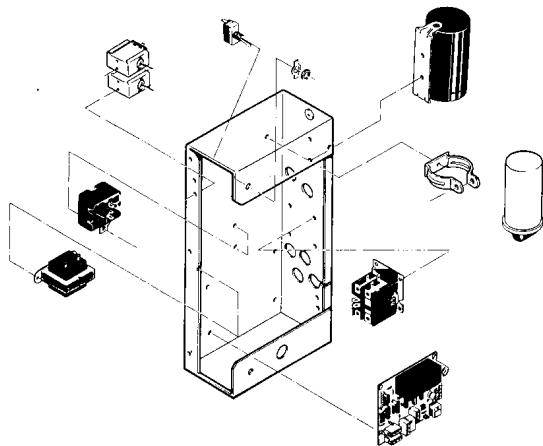
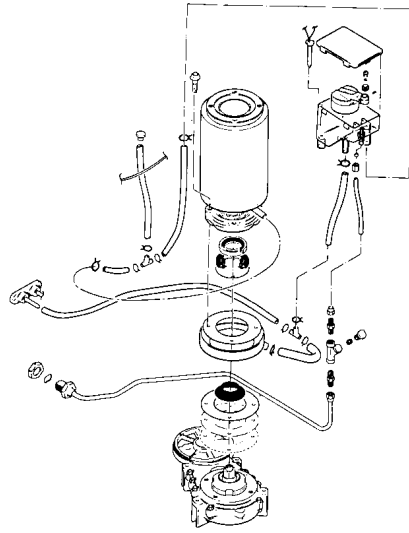
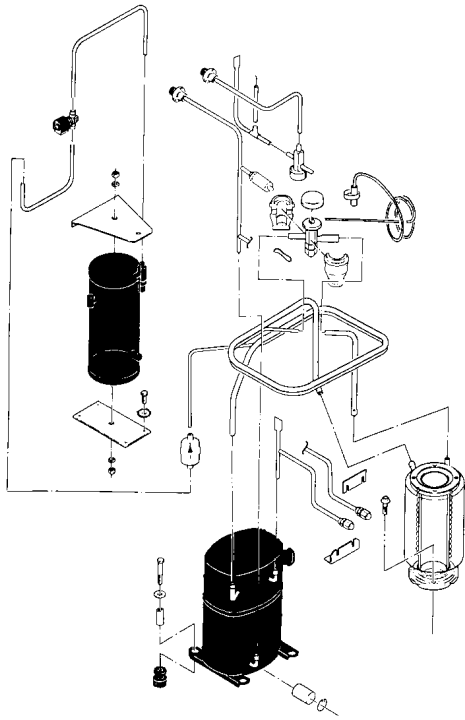

FM1200R SERVICE PARTS

Cabinet Assembly

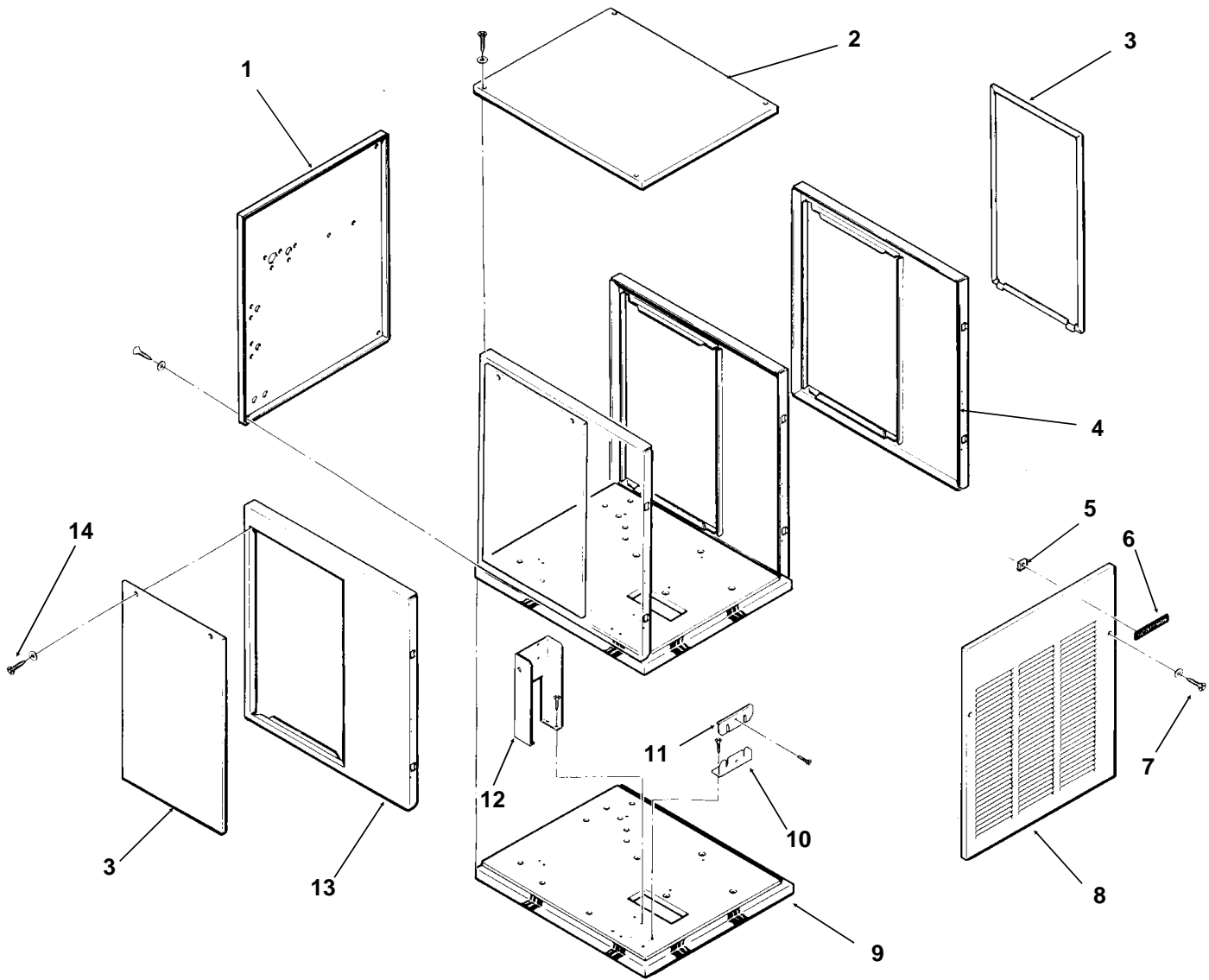

ITEM NUMBER	PART NUMBER	DESCRIPTION	ITEM NUMBER	PART NUMBER	DESCRIPTION
1	A33252-001	Back Panel, Painted	8	A33255-001	Front Panel, Painted
2	A33256-001	Top Panel, Painted		A33255-002	Front Panel, S.S.
	A33256-002	Top Panel, S.S.	9	A34042-001	Base Assembly
3	A34038-001	Service Panel, Painted	10	A31462-001	Tube Bracket
	A34038-002	Service Panel, S.S.	11	A31461-001	Tube Bracket
4	A33292-001	Right Side Panel, Painted	12	A34039-001	Control Box Support
	A33292-002	Right Side Panel, S.S.	13	A32435-001	Left Side Panel, Painted
5	03-0271-00	Speed Clip		A32435-002	Left Side Panel, S.S.
6	15-0711-01	Emblem	14	03-1404-12	Screw
7	03-1419-08	Screw			

FM1200R SERVICE PARTS

Refrigeration System

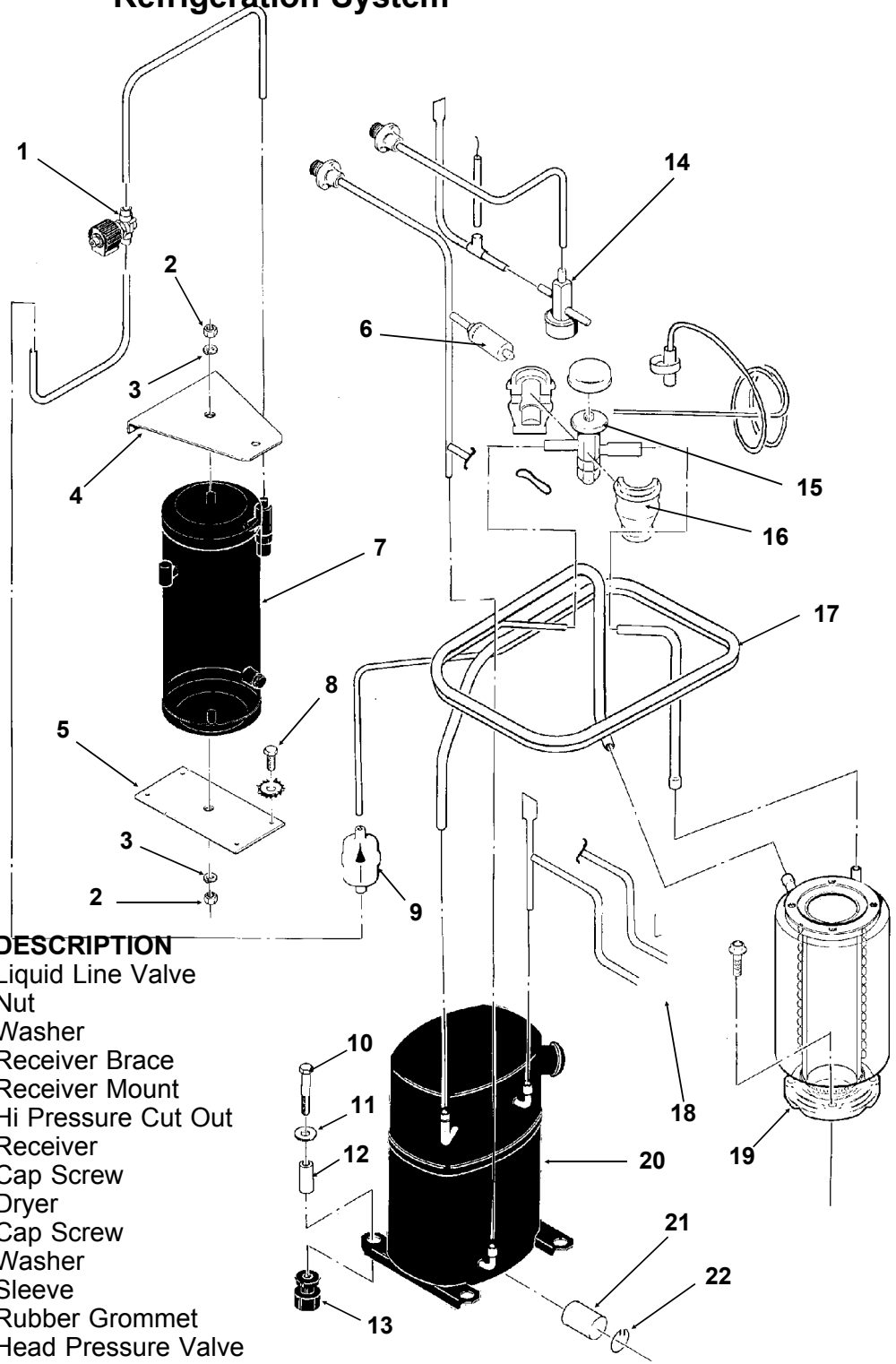

NOTE: Compressors have internal overloads.

ITEM NUMBER	PART NUMBER	DESCRIPTION
1	12-2257-21	Liquid Line Valve
2	03-1406-13	Nut
3	03-1410-06	Washer
4	A32968-001	Receiver Brace
5	A31801-002	Receiver Mount
6	11-0446-23	Hi Pressure Cut Out
7	16-0761-01	Receiver
8	03-1645-01	Cap Screw
9	02-3319-02	Dryer
10	03-1405-20	Cap Screw
11	03-1407-07	Washer
12	18-2300-26	Sleeve
13	18-6800-01	Rubber Grommet
14	11-0422-22	Head Pressure Valve
15	16-0780-21	Thermo Expansion Valve
16	A32961-020	Insulation Kit for TXV
17	A34050-001	Suction Line
18	16-0560-00	Core
18	16-0563-00	Nut

ITEM NUMBER	PART NUMBER	DESCRIPTION
19	A32890-020	Evaporator
20	18-8879-21	Compressor (1 Phase)
	18-8879-22	Compressor (3 Phase)
21	18-2308-01	Crankcase Heater
22	18-2309-01	Clip

FM1200R SERVICE PARTS

Water System, Water Seal

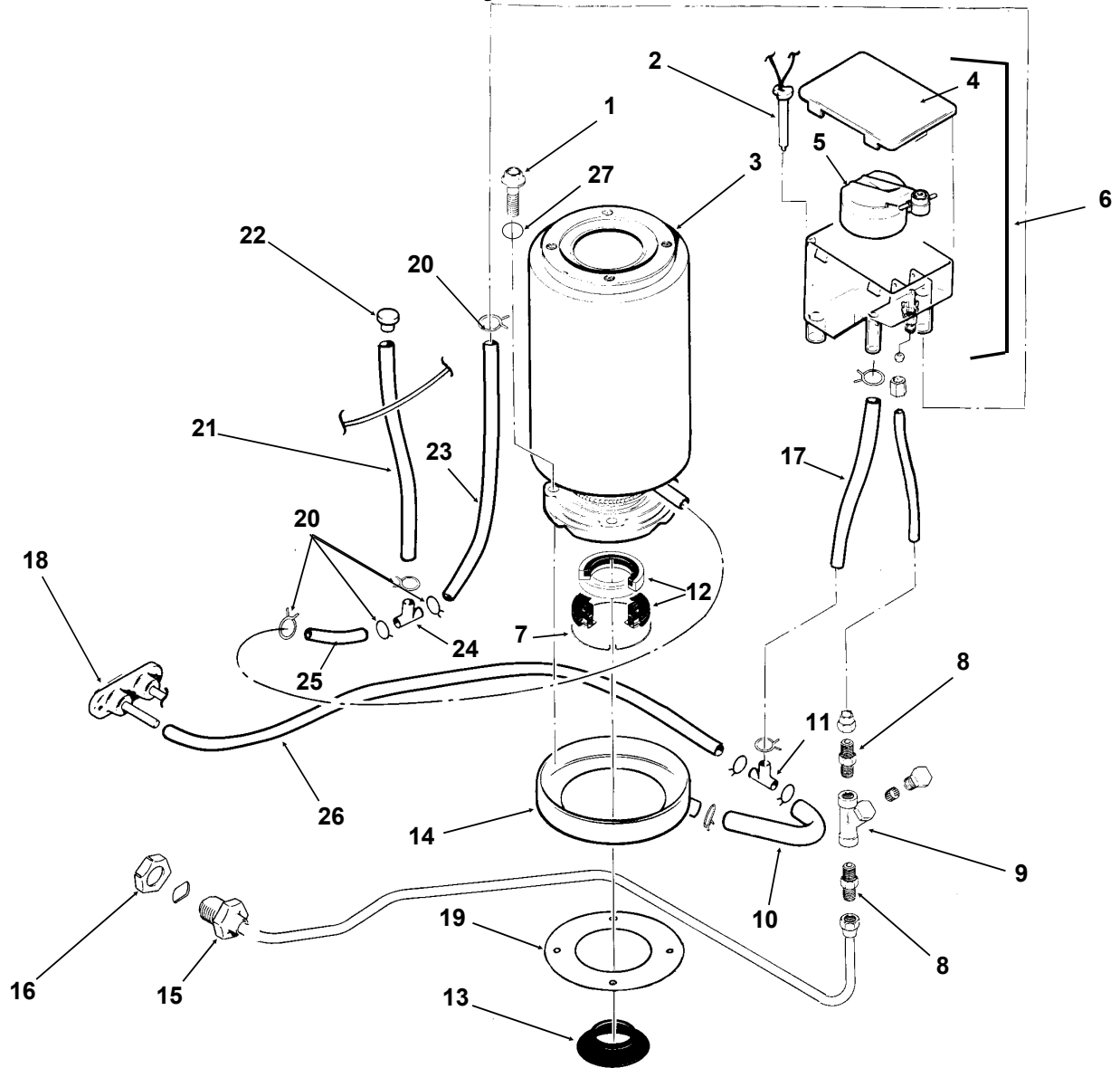

ITEM NUMBER	PART NUMBER	DESCRIPTION	ITEM NUMBER	PART NUMBER	DESCRIPTION
1	03-1420-03	Cap Screw	14	A32050-001	Drip Pan
2	A33101-022	Water Level Sensor	15	A27318-001	Water Inlet Fitting
3	A32890-020	Evaporator	16	03-1394-01	Pal Nut
4	02-2936-01	Res. Cover	17	13-0079-03	Res. Overflow, 8" req.
5	A32907-001	Float Assembly with pin, housing seal, rubber seat, insert & float	18	A34045-001	Drain Casting
	02-3190-01	Rubber seat	19	13-0704-00	Gasket
6	A32929-020	Reservoir Assembly	20	02-2814-08	Clamps
7	A32777-001	Retaining Ring for Seal	21	13-0674-06	Evap. Drain, 14" req.
8	16-0791-01	Half Union	22	A33205-001	Plug
9	16-0162-00	Strainer	23	13-0674-06	Evap. Inlet Tube, 5" req.
10	13-0079-03	Tube, 3.2" req.	24	16-0670-01	Tee
11	16-0670-02	Tee	25	A33203-001	Tube, Preformed
12	02-0929-23	Water Seal	26	13-0079-03	Drain Tube, 24" req.
13	13-0868-01	Water Shed	27.	03-1417-13	Lockwasher

FM1200R SERVICE PARTS

Gearmotor

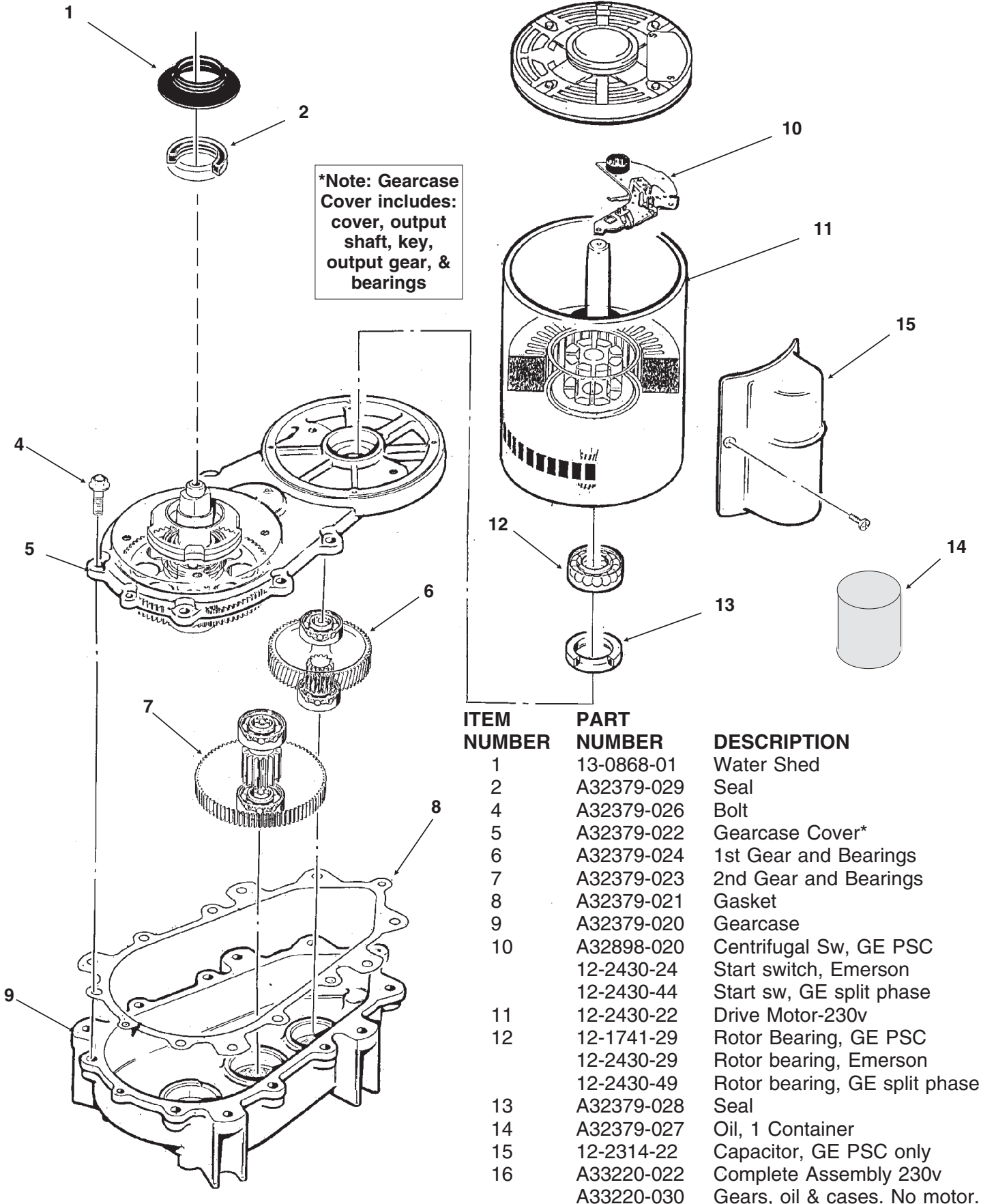

ITEM NUMBER	PART NUMBER	DESCRIPTION
1	13-0868-01	Water Shed
2	A32379-029	Seal
4	A32379-026	Bolt
5	A32379-022	Gearcase Cover*
6	A32379-024	1st Gear and Bearings
7	A32379-023	2nd Gear and Bearings
8	A32379-021	Gasket
9	A32379-020	Gearcase
10	A32898-020	Centrifugal Sw, GE PSC
	12-2430-24	Start switch, Emerson
	12-2430-44	Start sw, GE split phase
11	12-2430-22	Drive Motor-230v
12	12-1741-29	Rotor Bearing, GE PSC
	12-2430-29	Rotor bearing, Emerson
	12-2430-49	Rotor bearing, GE split phase
13	A32379-028	Seal
14	A32379-027	Oil, 1 Container
15	12-2314-22	Capacitor, GE PSC only
16	A33220-022	Complete Assembly 230v
	A33220-030	Gears, oil & cases. No motor.

FM1200R SERVICE PARTS

Evaporator, Bin Controls

Note: Bail clamp,
pn A34969-001
used beginning in
Jan. 91

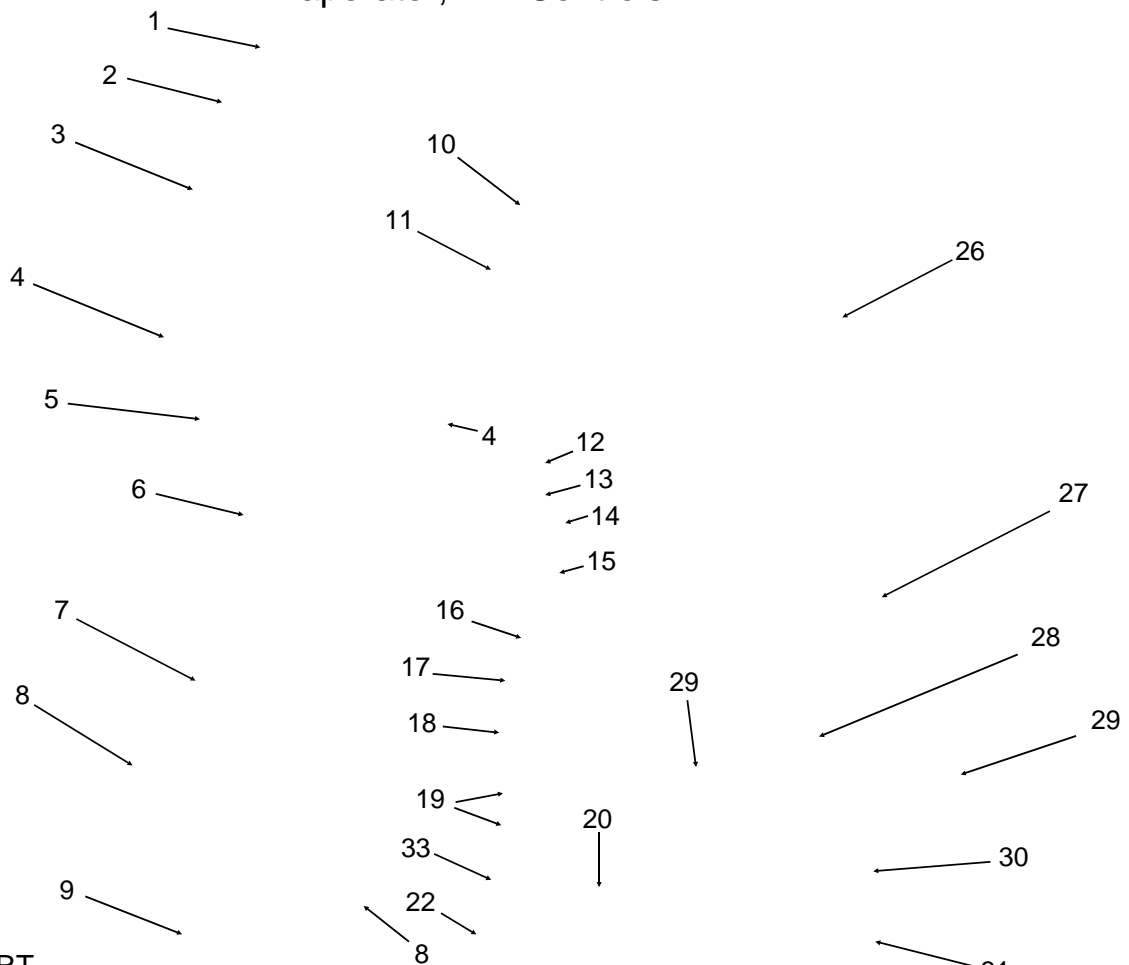

ITEM NUMBER	PART NUMBER	DESCRIPTION
1.	02-2933-01	Hex Stud
2.	A32891-020	Switch Assembly
	13-0617-53	O-ring
	12-2398-01	Man. reset switch
3.	02-2930-01	Ice Chute Cover
4.	A32963-001	Insulation Top (half)
5.	02-2926-01	Ice Chute Body
6.	A33102-001	Insulation Collar Inside
	A35419-020	Strap kit
7.	02-2929-01	Ice Chute Lower
8.	A37708-021	Ice level sensors (set of 2)
9.	A32930-001	Chute Gasket
10.	03-1405-52	Hex Cap Screw
11.	02-3001-01	Ice Sweep
12.	13-0871-01	Water Shed
13.	02-2978-01	Lip Seal
14.	02-3128-20	Breaker Cover
15.	13-0617-54	O-Ring
16.	08-0660-01	Auger Stud & washer
17.	part of item 16	
18.	A34559-020	Bearing
19.	02-2977-01	Lip Seal
20.	03-1405-27	Screw
21.	13-0617-52	O-Ring
22.	02-2916-01	Slotted Collar
23.	13-0617-45	O-Ring
24.	03-1544-08	Soc. Head Screw
25.	A34505-020	Breaker (Divider) (includes 18 & 19)
26.	A38071-022	Auger
27.	A32890-020	Evaporator
28.	03-1420-03	Cap Screw
29.	A32962-001	Insulation Bot. (half)
	A32962-002	Insulation (half)
30.	A32050-001	Drip Pan
31.	13-0704-00	Drip Pan Gasket
32.	A31340-001	Water Shed
33.	13-0617-49	O-ring

FM1200R SERVICE PARTS

Control Box

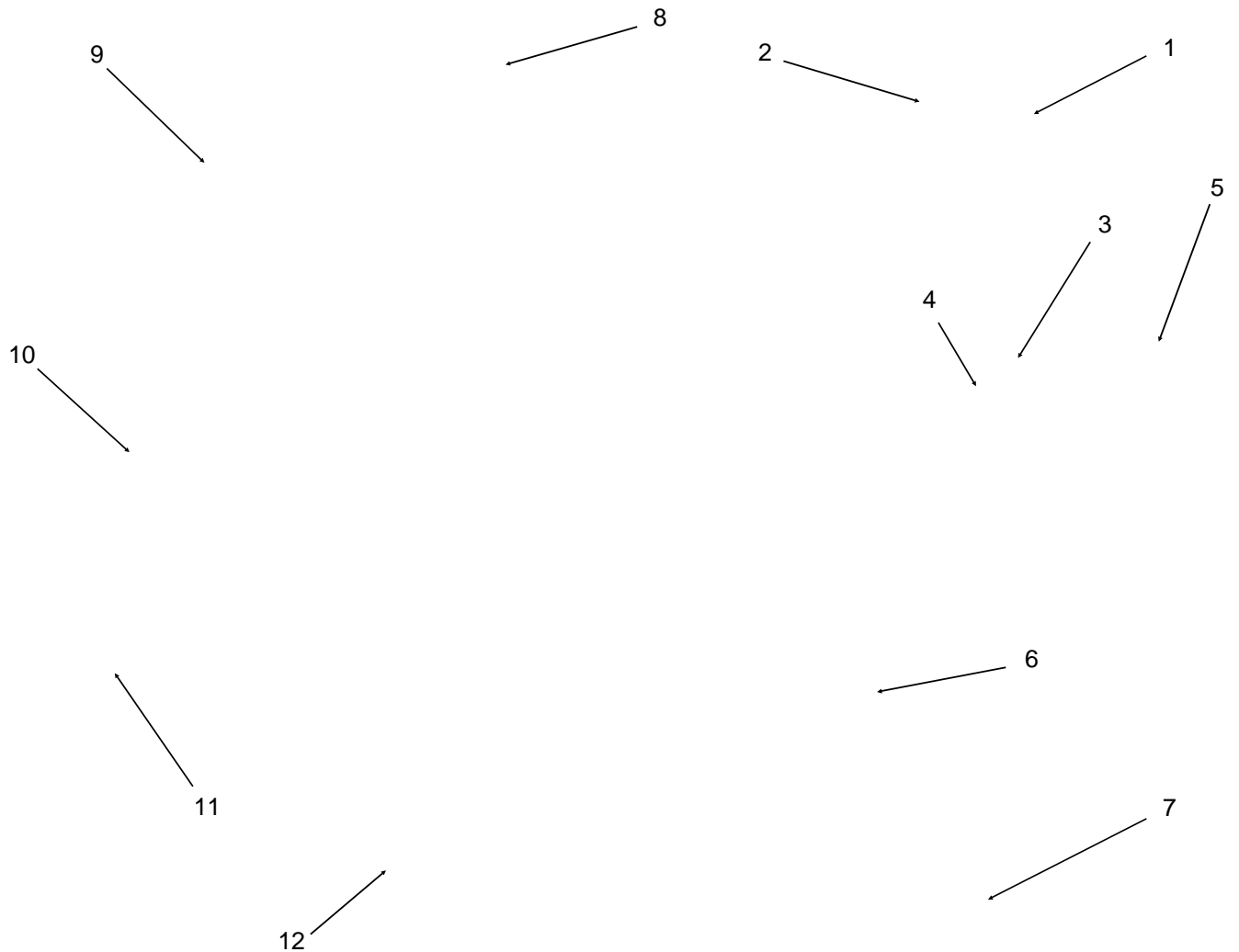

ITEM NUMBER	PART NUMBER	DESCRIPTION	ITEM NUMBER	PART NUMBER	DESCRIPTION
1	18-1901-48	Start Capacitor	7	A32976-020	Circuit Board
	18-4300-50	Start Capacitor Cap.	8.	12-0426-01	Master Switch
2.	18-2200-39	Start Capacitor Bracket	9.	11-0420-23	Pump Down Control
	03-1638-04	Screw	10	18-1903-46	Potential Relay
	03-1417-15	Lockwasher	11.	12-2285-22	Transformer
3.	A32872-001	Run Cap Bracket	12	no number	Control Box Assy
	03-1652-02	Bolt	NOT ILLUSTRATED		
	03-0255-04	Wing Nut	13.	12-2337-02	3 Pin Plug Assy (Safety Circuit to Circuit Board)
4.	03-1638-03	Screw	14.	12-2340-01	4 Pin Plug Assy (Transformer to Circuit Board)
5.	18-1902-45	Run Capacitor	15.	A34055-001	Control box cover
6.	12-2469-03	Single Phase Contactor			
	12-0739-02	Three Phase Contactor			

FM1200R SERVICE PARTS REMOTE CONDENSER

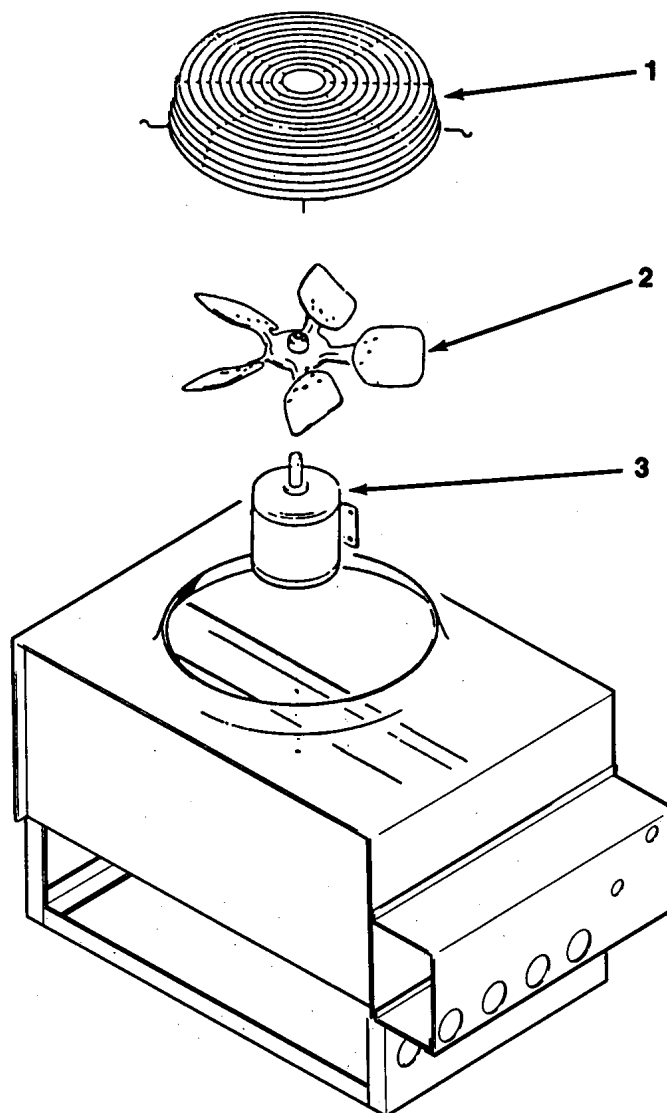

**RC1451-32B or
RC1051-32A or RC1052-32A**

ITEM NUMBER	PART NUMBER	DESCRIPTION
1.	02-2628-01	Fan Guard
2.	18-6304-01	Fan Blade
3.	18-5301-01	Fan Motor

RC651-32B or RC652-32B

ITEM NUMBER	PART NUMBER	DESCRIPTION
1.	02-2618-01	Fan Guard
2.	18-3733-01	Fan Blade
3.	18-5301-01	Fan Motor

FM1200R SERVICE PARTS

Wiring Diagram, 208-230/60/1

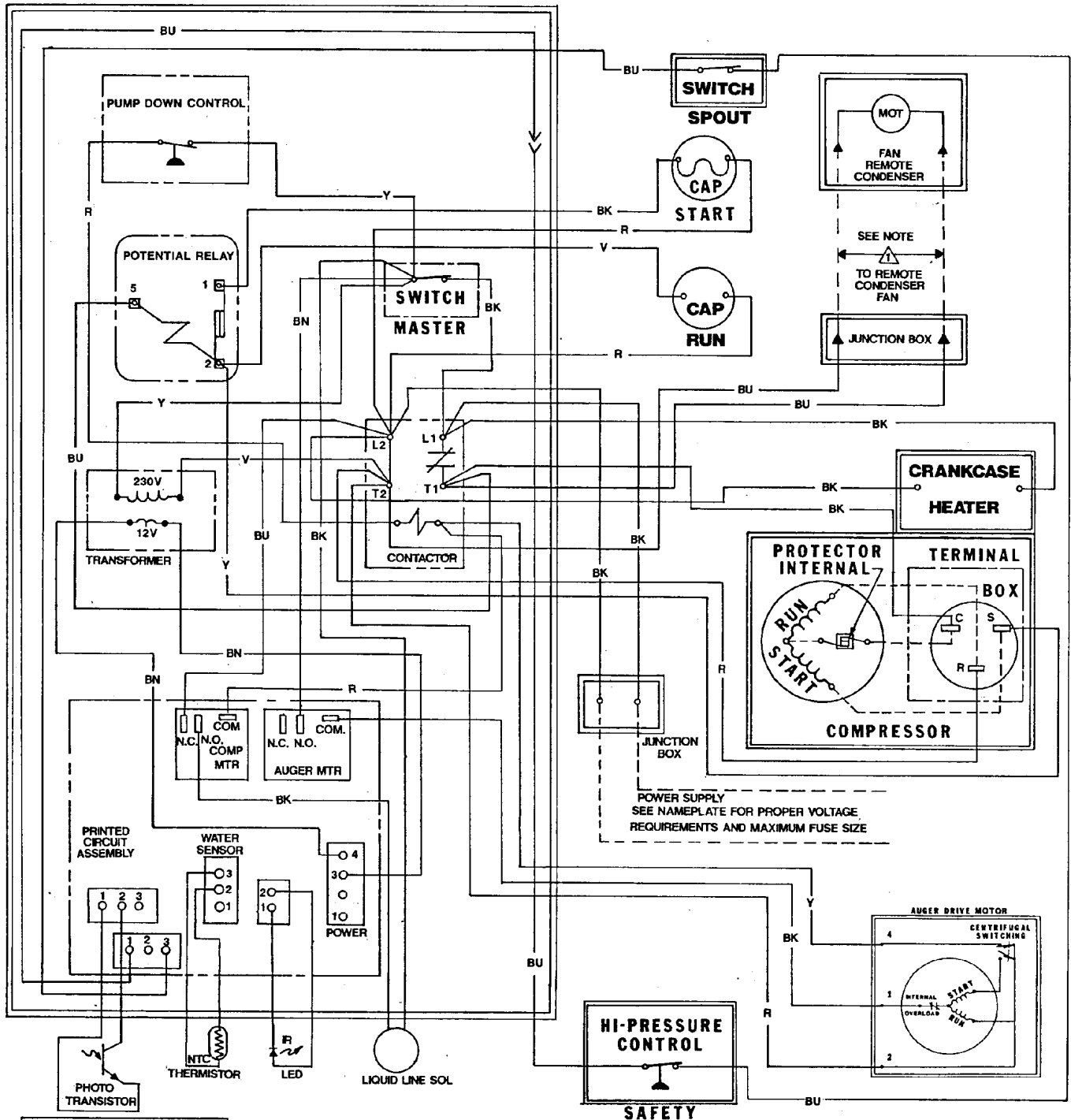

A34492-032

FM1200R SERVICE PARTS

Schematic Diagram, 208-230/60/1

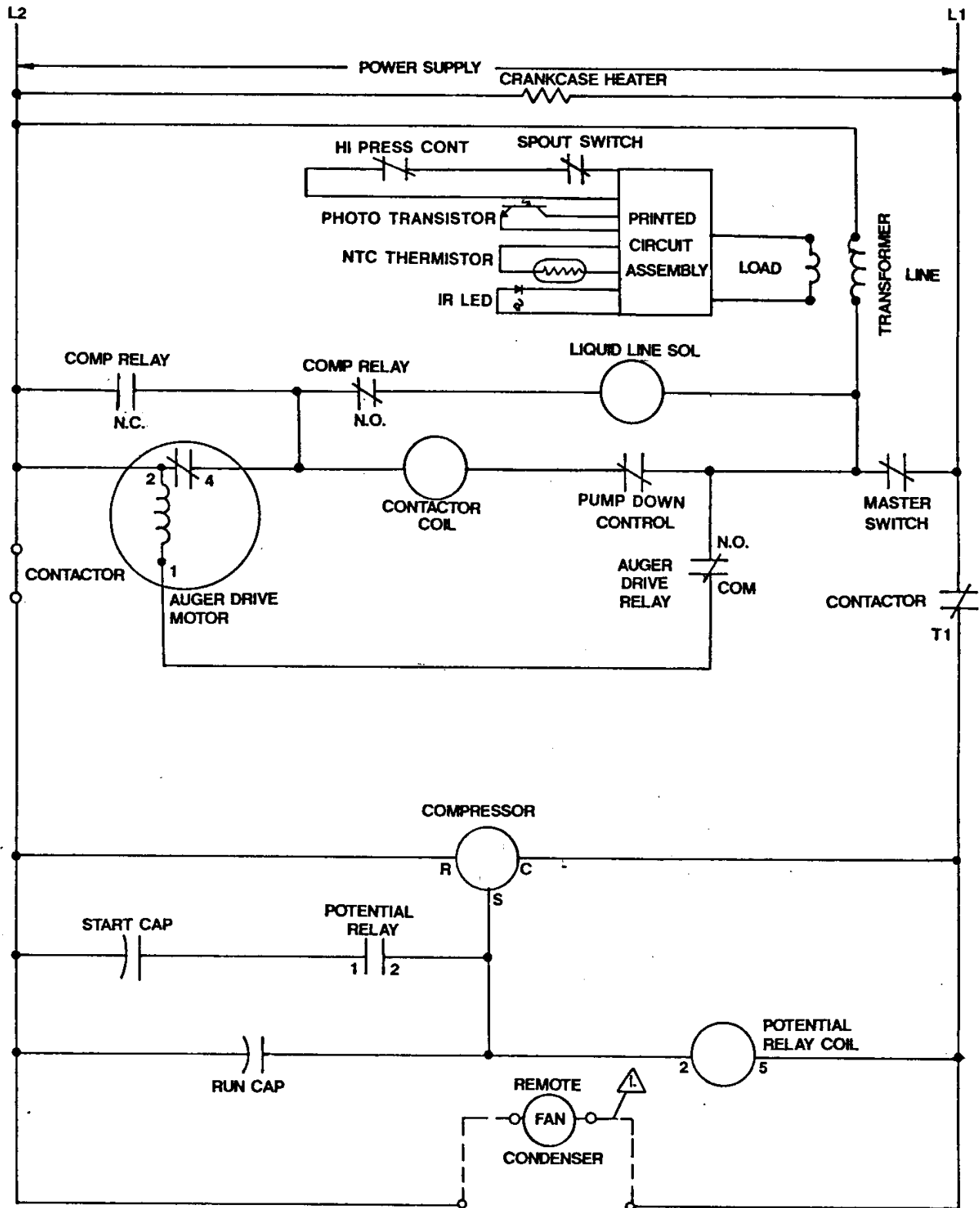

USE COPPER CONDUCTORS ONLY THIS UNIT MUST BE GROUNDED

All Controls Shown in Normal Ice Making Mode.

Note: Dashed lines indicate field wiring which must be installed in accordance with the National Electric Code Using a Minimum of 14 ga. awg. wire.

FM1200R SERVICE PARTS

Wiring Diagram, 208-230/60/3

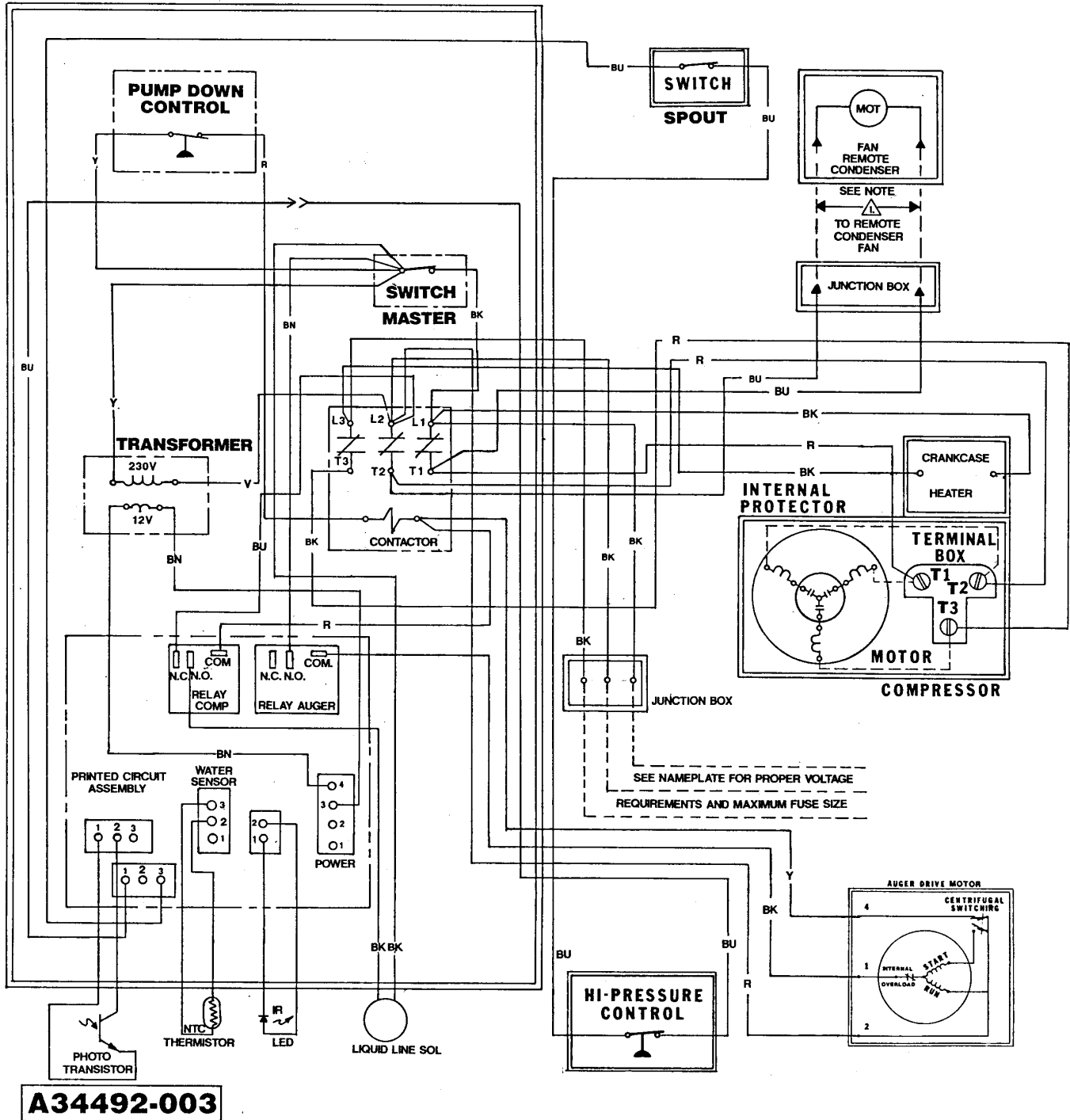

FM1200R SERVICE PARTS

Schematic Diagram, 208-230/60/3

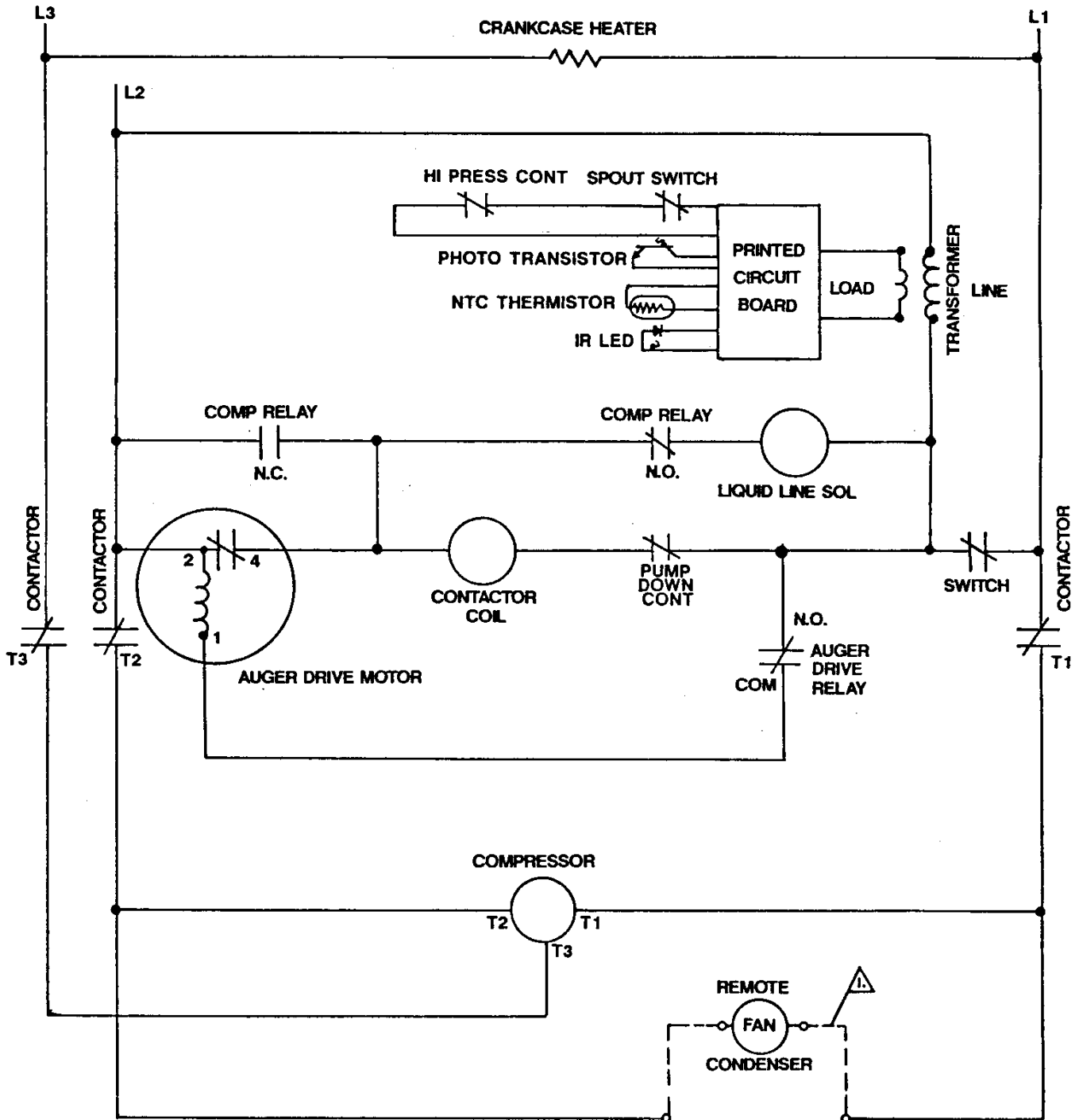

USE COPPER CONDUCTORS ONLY THIS UNIT MUST BE GROUNDED

All Controls Shown in Normal Ice Making Mode.

Note: Dashed lines indicate field wiring which must be installed in accordance with the National Electric Code Using a Minimum of 14 ga. awg. wire.