

# FDE474 Service Parts

This parts lists contains part numbers for the service parts available for the FDE474. The FDE474 has been manufactured in both 60 Hz and 50 Hz models. The 60 Hz models are:

- FDE474AS-1A

The 50 Hz models are:

- FDE474AS-6A

Always check the model number of the ice machine being serviced to be certain that the parts ordered will be correct.

## Table of Contents

Cabinet .....	Page 2
Condensing Components .....	Page 3
Evaporator, Auger, Bearings & Water Seal .....	Page 4
Water And Drain System .....	Page 5
Bin Cover, Dispenser Motor, Electric Eyes .....	Page 6
Gear Reducer and Motor .....	Page 7
Control Box .....	Page 8
Wiring Diagrams .....	Page 9

# FDE474 Service Parts Cabinet

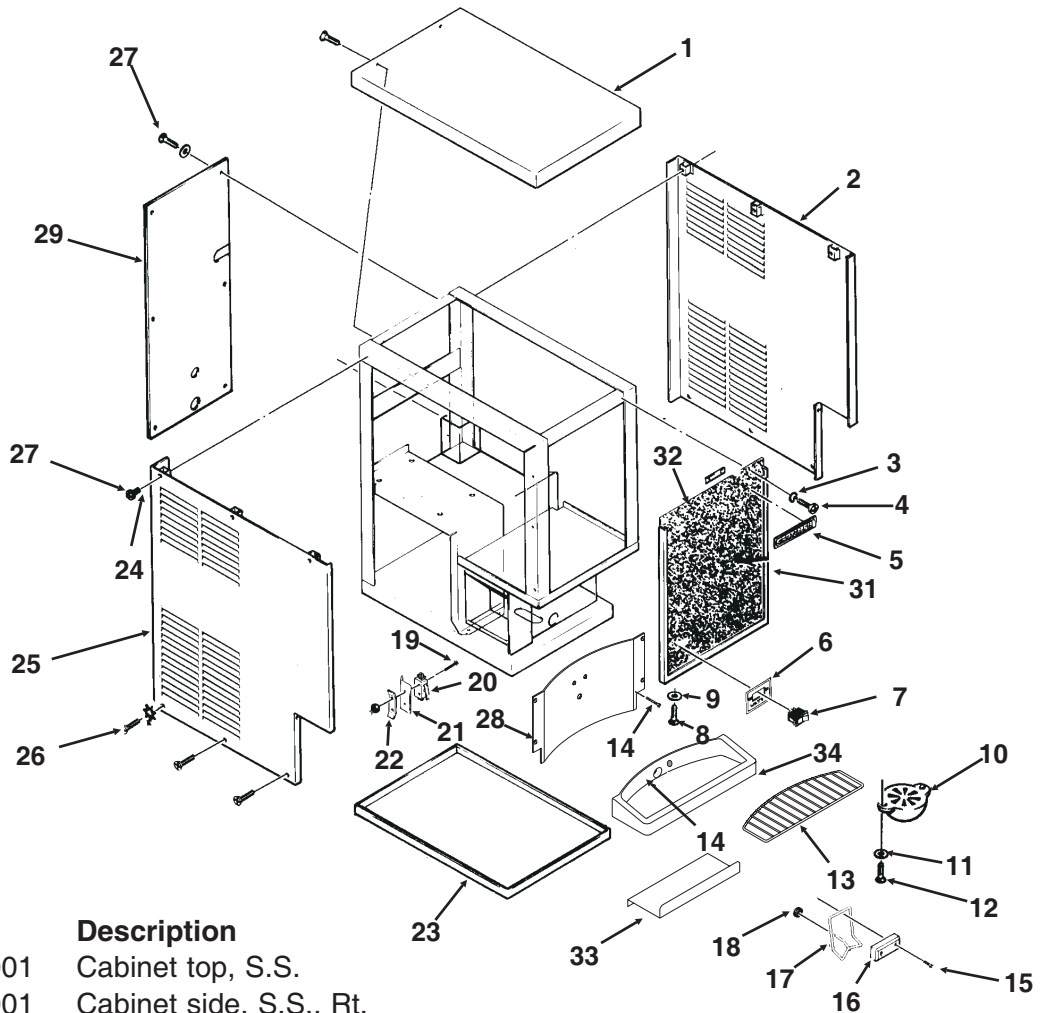

Item Number	Part Number	Description	Item Number	Part Number	Description
1	A16317-001	Cabinet top, S.S.	21	A22339-000	Insulation
2	A21416-001	Cabinet side, S.S., Rt.	22	03-0886-00	Nut
3	13-0616-00	Rubber bumper	23	13-0566-01	Moulding
4	03-1404-11	Screw	24	03-1417-27	Washer
5	15-0718-02	Emblem for S.S.	25	A21415-001	Cabinet side, S.S., Lt.
6	15-0621-02	Water decal	26	03-1419-13	Screw
7	12-1377-00	Switch	27	03-1404-09	Screw
8	03-1403-15	Screw	28	02-3300-01	Splash panel
9	03-1417-27	Washer	29	A21405-001	Back panel, SS
10	02-1804-00	Spout	30	03-1403-17	Screw
11	03-1407-03	Washer	31	15-0507-00	Moulding trim
12	03-1403-19	Screw	32	A27500-001	Front panel, SS
13	02-3302-02	Grill	33	A35875-015	Bracket
14	03-1419-17	Screw	34	02-3402-30	Sink
15	03-1419-09	Screw			
16	02-1833-00	Adapter			
17	A21544-000	Actuator arm			
18	12-1213-04	Bushing			
19	03-1403-09	Screw			
20	12-1641-00	Switch			

# FDE474 Service Parts

## Condensing Components

Item Number	Part Number	Description
1	18-8741-21	60 Hz compressor
	18-8741-26	50 Hz compressor
2	18-8741-27	Overload for 60 Hz
	18-8741-22	Overload for 50 Hz
3	18-8741-28	60 Hz relay
	18-8741-23	50 hz relay
4	18-8741-29	Start capacitor for 60 Hz
	18-8741-24	Start capacitor for 50 Hz
5	03-1647-01	Screw
	03-1417-12	Washer
	03-1407-07	Washer
	18-4700-28	Grommet
6	18-0108-40	Sleeve
6a	16-0832-21	Access valve
6b	16-0832-03	Core cap
6b	16-0832-02	Stem cap
7	18-0422-00	Fan motor bracket
8	18-7200-02	60 Hz fan motor
	18-7200-03	50 Hz fan motor
9	18-8743-01	Fan blade
10	A36094-001	Fan shroud
11	18-8846-01	Condenser
12	02-3319-01	Drier

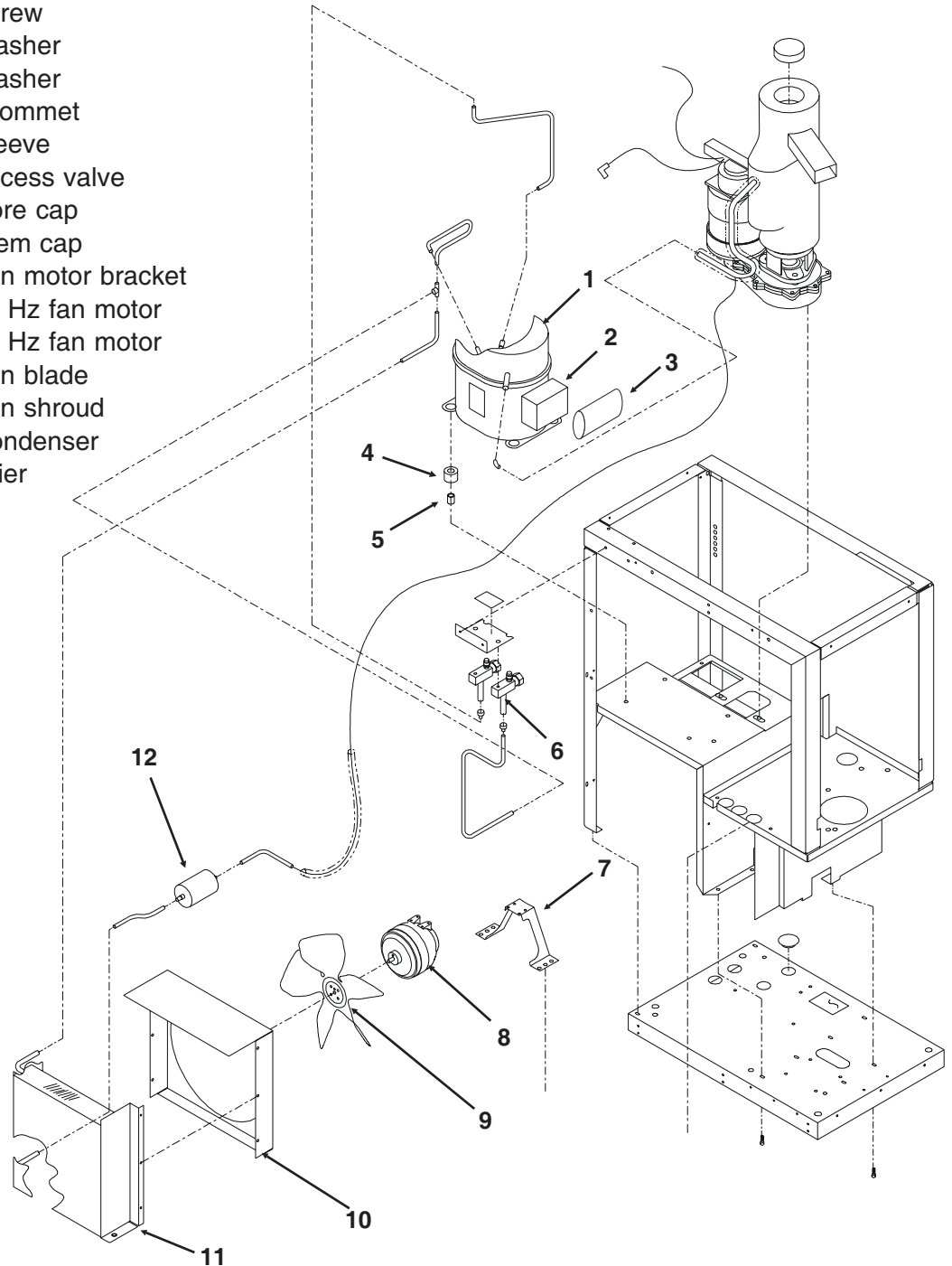

# FDE474 Service Parts

## Evaporator, Auger, Bearings & Water Seal

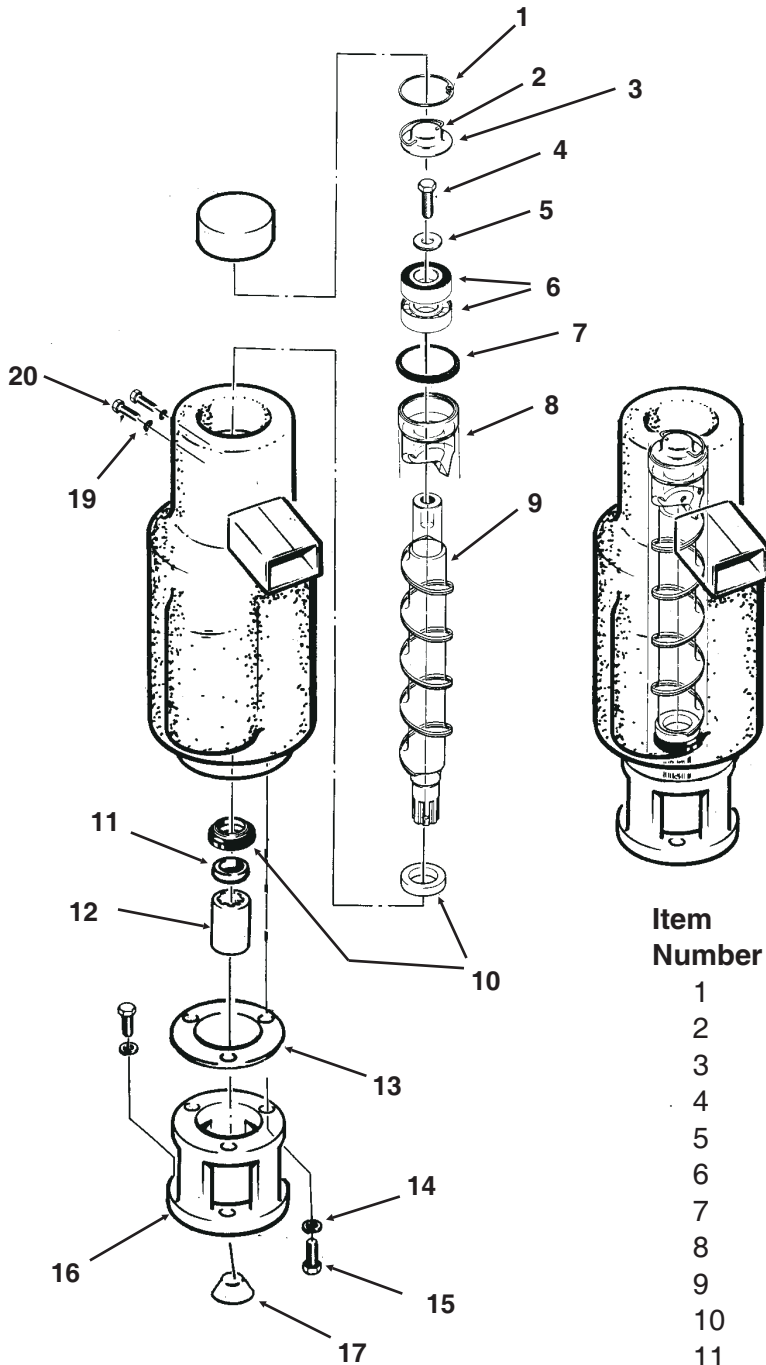

Item Number	Part Number	Description
1	03-1558-03	Retainer Ring
2	A08162-000	Cap hook
3	A07701-000	Cap
4	03-0758-00	Screw
5	A07699-000	Washer
6	02-1412-20	Top bearing set
7	13-0617-16	"O" ring
8	A14591-020	Breaker with bearing
9	02-4023-20	Auger
10	02-1300-01	Water seal
11	02-0417-20	Bottom bearing
12	A29915-002	Coupling
13	03-1505-00	Gasket
14	03-1410-04	Washer
15	03-1420-01	Cap screw
16	08-0595-01	Adapter
17	13-0709-01	Rubber drip shield
18	A36081-020	Evaporator
19	03-1417-07	Washer
20	03-1403-46	Screw

# FDE474 Service Parts Water And Drain System

Item Number	Part Number	Description
1	A37893-001	Vane Assembly
2	A38272-001	Bin Bottom Assy
3	02-3033-01	Hub Assembly
4	03-1409-22	Fiber Washer
5	A36118-020	Storage Bin
6	13-0895-01	Inlet water line requires 26"
7	03-1394-00	Pal Nut
8	12-1434-04	Water valve (60 hz)
	12-1434-05	Water valve (50 Hz)
9	16-0869-01	Barbed adapter
10	13-0674-02	Tubing, 12" req.
11	12-2760-21	Water sensor
12	02-3402-30	Sink
13	02-3302-02	Grill for sink
14	13-0674-07	Tube, requires 25"
15	02-2814-10	Clamps
16	13-0674-09	Tube, overflow to drain, requires 12"
17	02-2814-08	Clamp
18	02-2814-07	Clamp
19	02-3371-01	Reservoir Assy
20	A36402-001	Reservoir Bracket
21	02-3371-02	Float and arm
21a	02-3266-03	Plunger/seat
22	03-1407-05	Plain Washer
23	03-1645-01	Hex Cap Screw
24	13-0674-09	Tube (to evap.) req. 6"
25	A21433-000	Inlet fitting
26	16-0870-01	NPT to compr. fitting
27	16-0869-01	NPT barbed
28	02-2814-09	Clamp
29	16-0670-01	Tee

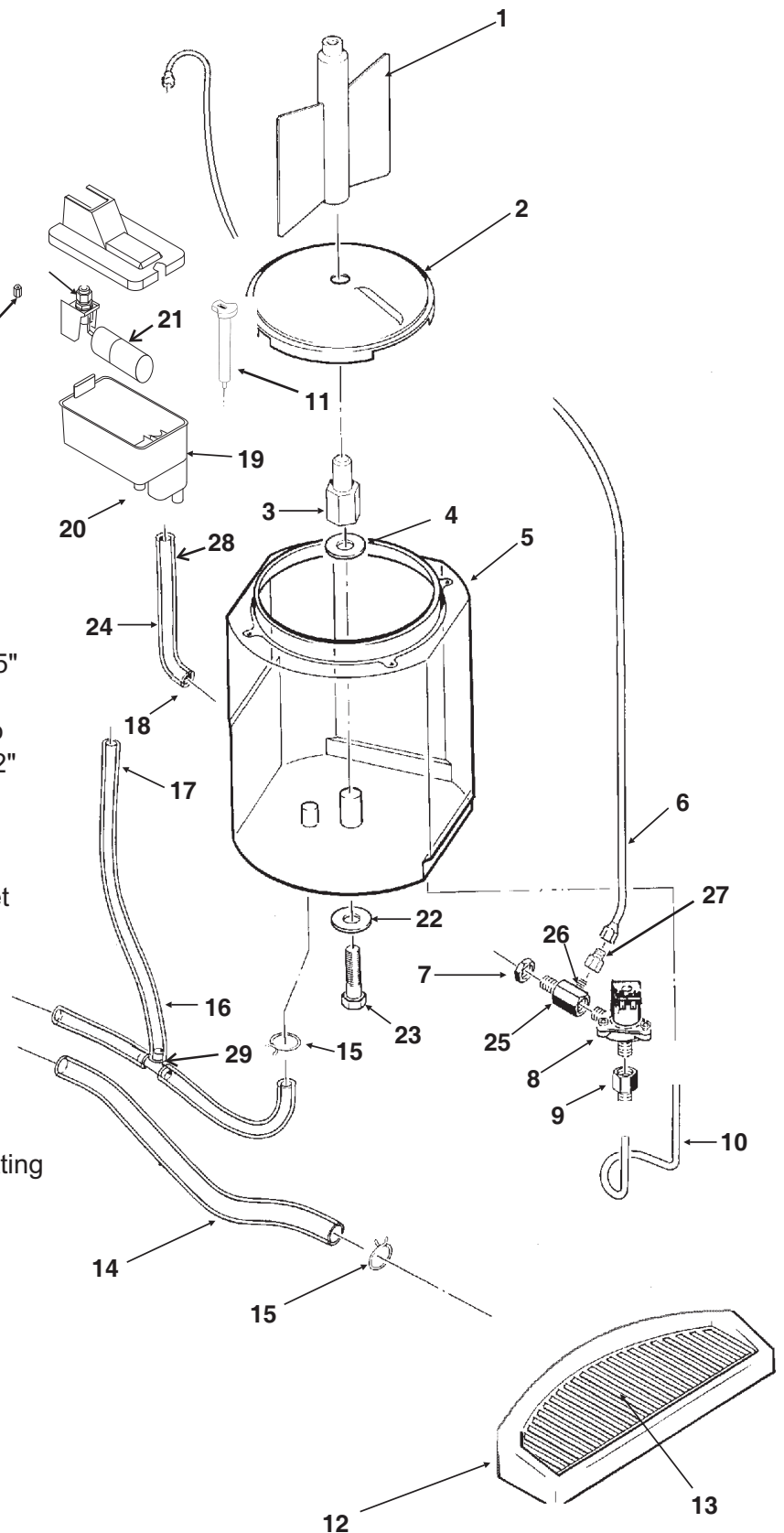

# FDE474 Service Parts

## Bin Cover, Dispenser Motor, Electric Eyes

Item Number	Part Number	Description
1	03-1403-15	Screw
2	03-1531-01	Screw
3	A35474-001	Motor Mtg. Bracket
4	02-3238-01	Bushing
5	03-0727-10	Thumbscrew
6	13-0866-01	Grommet
7	A37709-021	Electric eye set
8	02-3237-01	Bin top
9	02-3239-01	Nut
10	02-3241-01	Shaft
11	12-1610-01	Motor & gears 60 Hz
11	12-1610-06	Motor & gears 50 Hz
12	02-1801-02	Strap

A35483-021 Complete assembly 50 hz  
 A35483-026 Complete assembly 50 hz

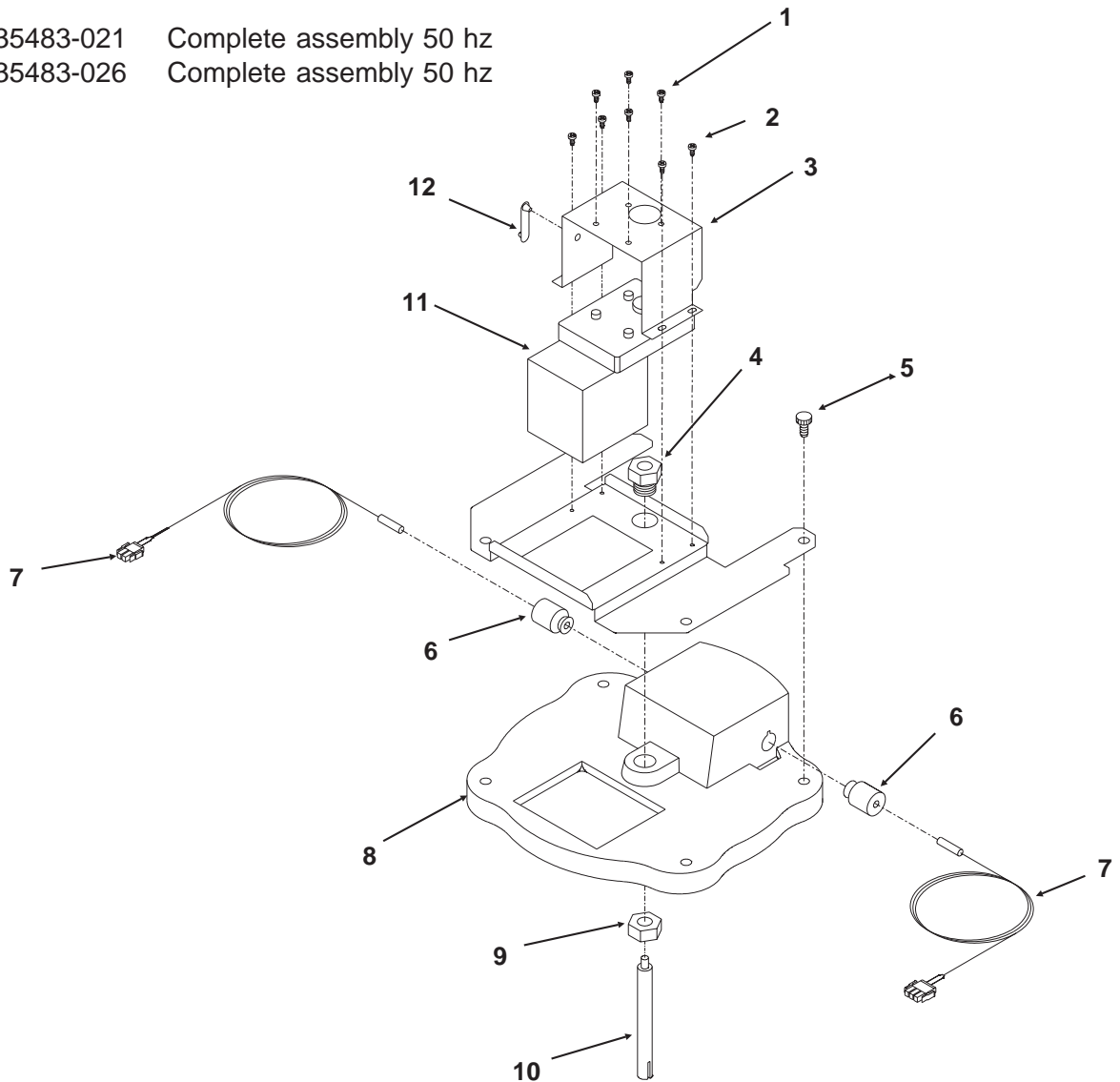

# FDE474 Service Parts

## Gear Reducer and Motor

Item Number	Part Number	Description
1	A27494-001	Centrifugal switch kit
2	12-2059-01	Switch
3	A27494-001	Housing
4	03-1403-77	Screw
5	A30579-001	Shaft & actuator
6	03-1408-36	Washer
7	A38487-001	Motor housing kit
8	A28168-001	Cooling fan
9	A37707-021	60 Hz motor kit*
	A38501-001	50 Hz motor kit*
10	see item 9	Rotor & bearing
11	03-1408-08	Washer
12	02-1501-00	Bearing
13	02-3936-20	Grease seal (input)
14	02-1503-00	Grease seal (output)
15	A28165-021	Gear case cover
16	03-1408-21	Washer**
17	03-1408-04	Washer**
18	02-2445-01	Output shaft**
19	03-1515-03	Retaining ring**
20	03-1602-01	Woodruff key**

\*includes items 7, 8, 9, 10, 11 and 12.

\*\* Does not apply to 02-4399-21 or 02-4399-24 or 02-4398-21. 02-4398-21 includes items 13 - 30 and oil. Correct oil charge is 5 oz.

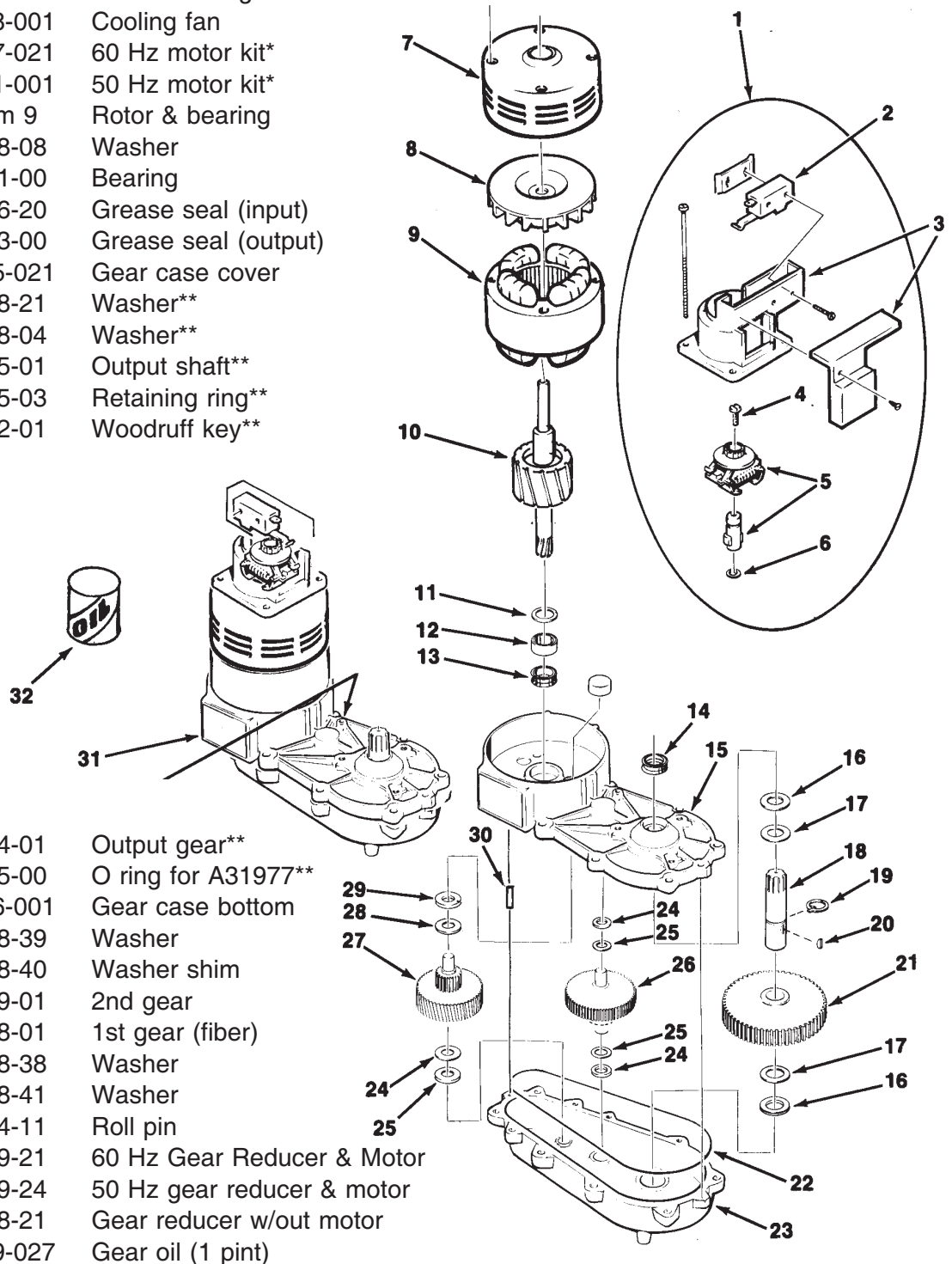

21	02-2444-01	Output gear**
22	02-1505-00	O ring for A31977**
23	A28166-001	Gear case bottom
24	03-1408-39	Washer
25	03-1408-40	Washer shim
26	02-2439-01	2nd gear
27	02-2438-01	1st gear (fiber)
28	03-1408-38	Washer
29	03-1408-41	Washer
30	03-0774-11	Roll pin
31	02-4399-21	60 Hz Gear Reducer & Motor
	02-4399-24	50 Hz gear reducer & motor
	02-4398-21	Gear reducer w/out motor
32	A32379-027	Gear oil (1 pint)

# FDE474 Service Parts Control Box

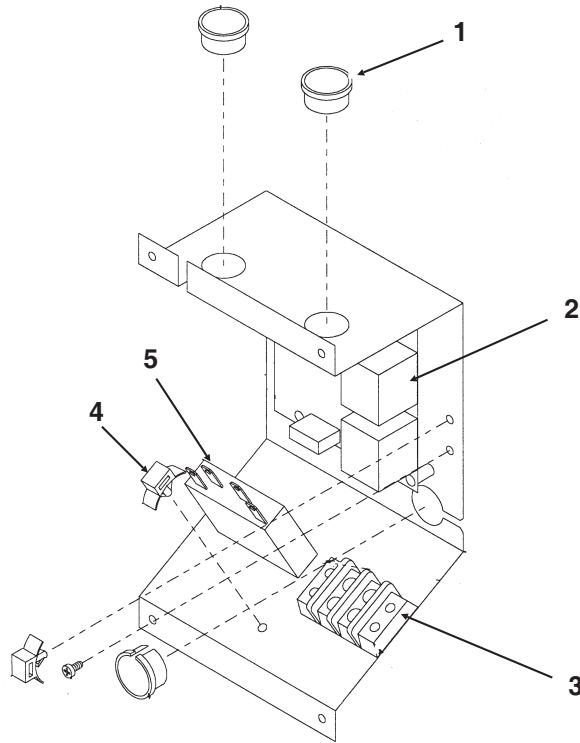

Item Number	Part Number	Description
1	12-1213-10	Snap bushing
2	12-2744-22	Circuit board
	12-2350-01	Stand off
3	12-0813-04	Terminal strip
4	02-3112-01	Wire mount
5	12-2679-02	60 Hz relay
	12-2679-03	50 Hz relay

Not shown

6 A35480-001 Control box cover

Not shown for FDE470A-1AG

7 12-2391-01 Key lock switch



# FDE474 Service Parts

## Wiring Diagram

### FDE474AS-1A

17-2712-01

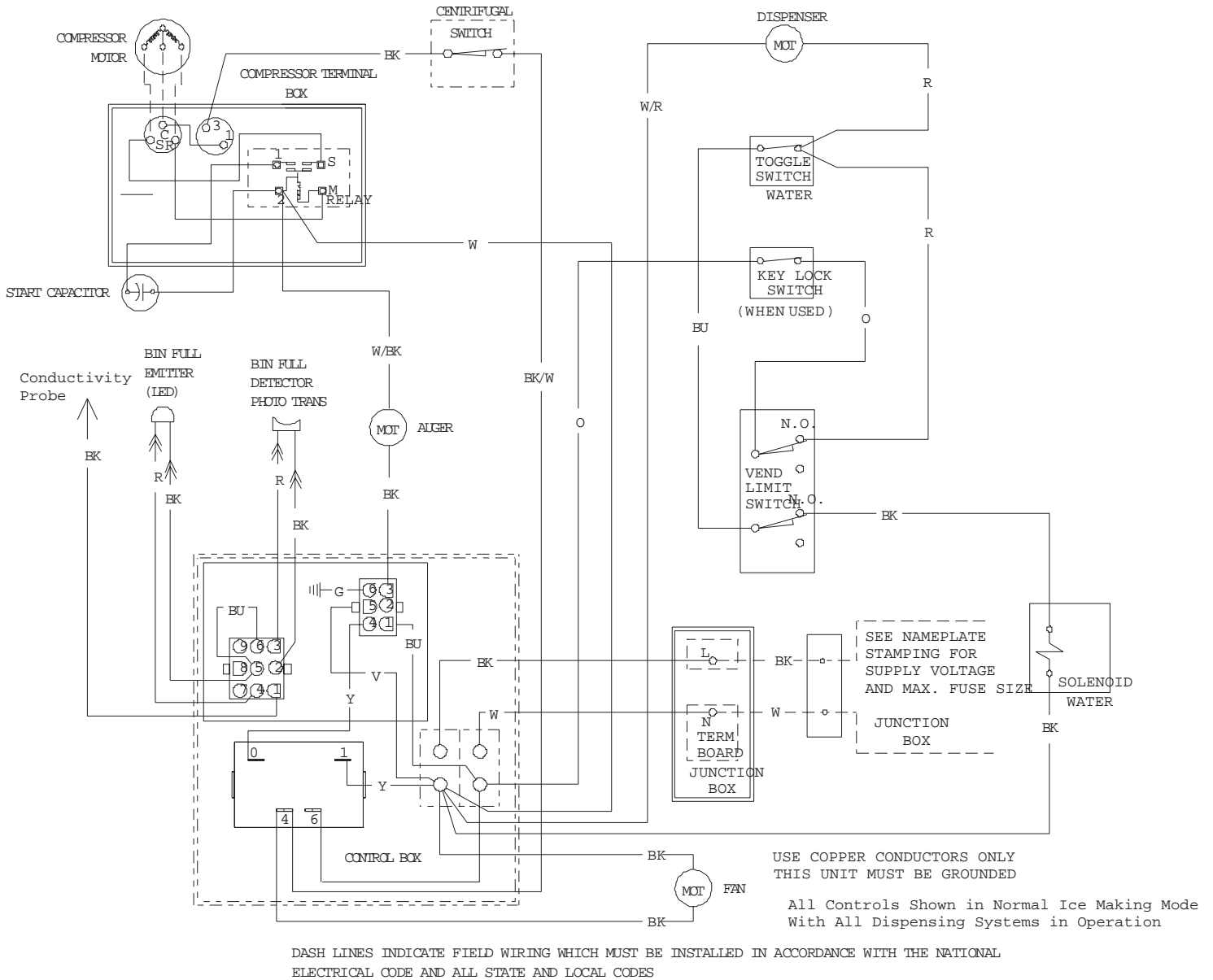

# FDE474 Service Parts Schematic Diagram FDE474AS-1A

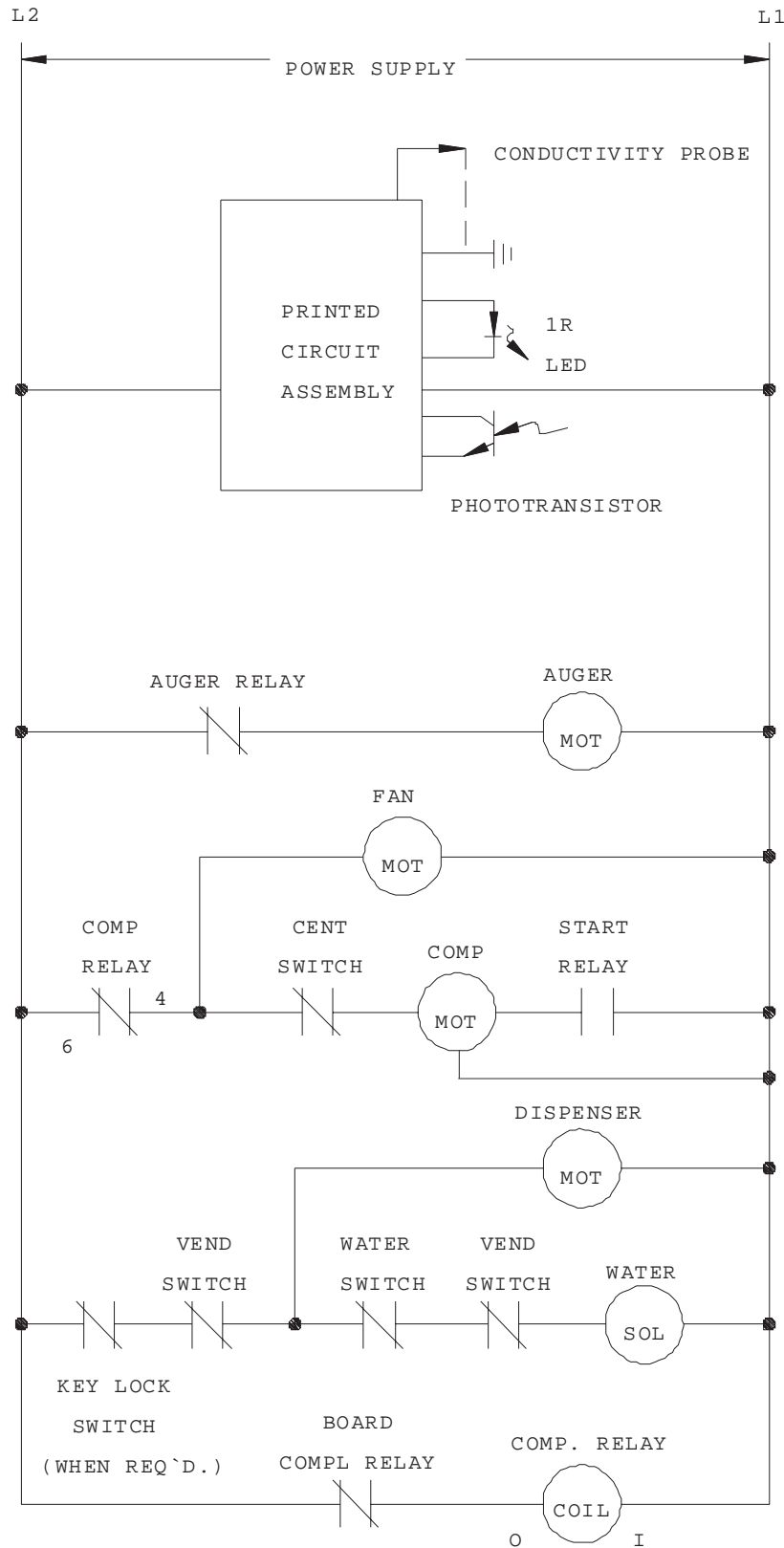

ALL CONTROLS SHOWN IN NORMAL ICE  
MAKING MODE WITH ALL DISPENSING  
SYSTEMS IN OPERATION.

# FDE474 Service Parts

## Wiring Diagram FDE474AS-6A

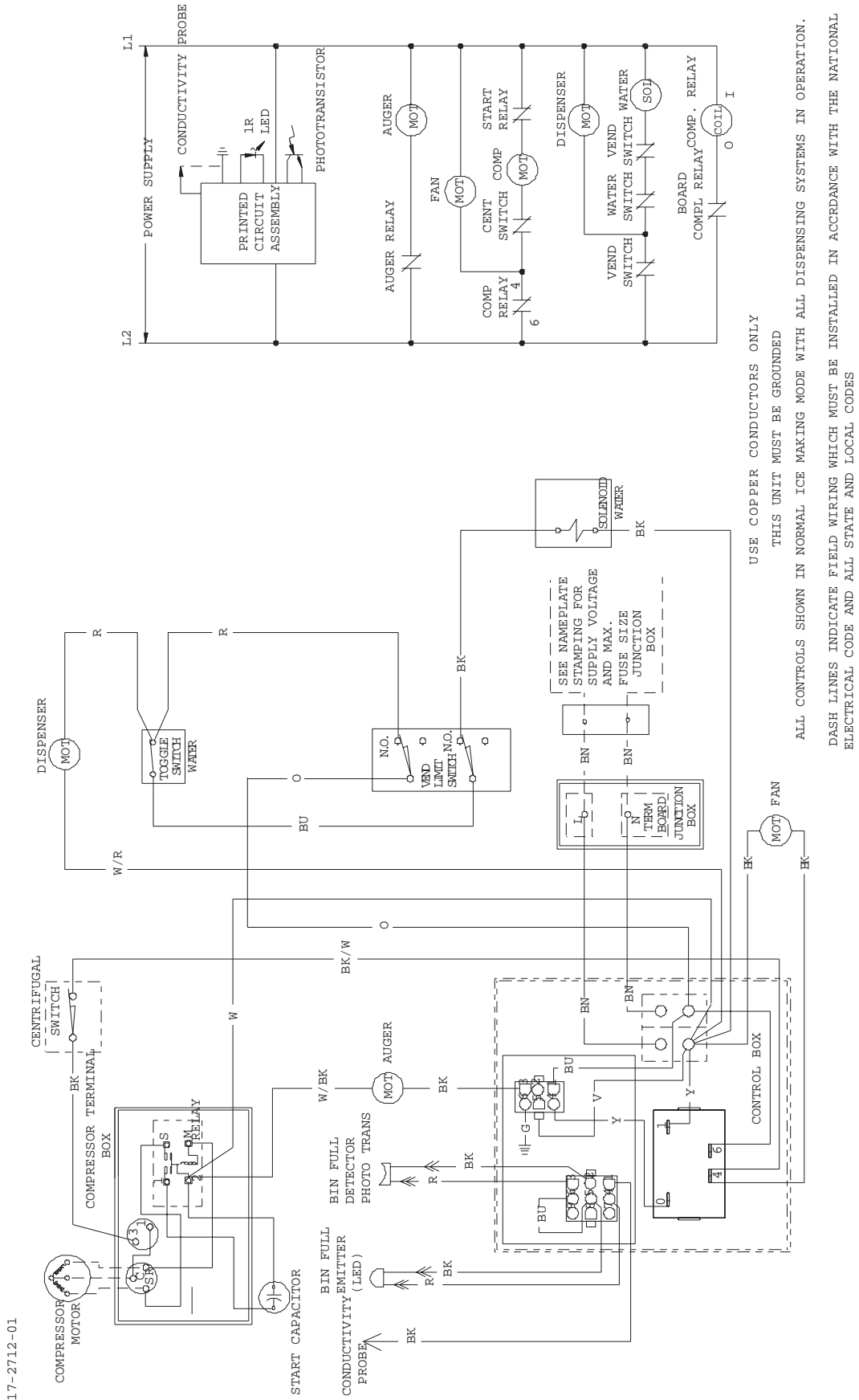

USE COPPER CONDUCTORS ONLY

THIS UNIT MUST BE GROUNDED

ALL CONTROLS SHOWN IN NORMAL ICE MAKING MODE WITH ALL DISPENSING SYSTEMS IN OPERATION.  
DASH LINES INDICATE FIELD WIRING WHICH MUST BE INSTALLED IN ACCORDANCE WITH THE NATIONAL ELECTRICAL CODE AND ALL STATE AND LOCAL CODES

17-2712-01

# SERVICE BULLETIN

## Subject: NME, FME, NSE, NDE and TDE550/650 Top Bearing Lubrication

Two parts have been made available as helpful aids to use when lubricating the top bearing.

1. **02-3559-01** is a needle that snaps onto a standard grease gun fitting. Use it to insert and deeply pack the proper lubricant into the top bearing.
2. **A36808-001** is a tube of the proper lubricant, also designed to fit a standard grease gun.

Both numbers are in the parts price list.

Needle, shown inserted into bearing

