

**Introduction**

---

To the owner or user: This product manual is a source of information about the installation, start up, cleaning, maintenance and repair of the product.

The SLD150 is a Slim Line® brand hotel/motel ice dispenser. It is designed to use a Scotsman Slim Line SLE300 or SLE400 ice machine as the source for ice.

Ice from the cuber falls into the insulated hopper, where it is stored until needed. When a user pushes the dispense button a rotating wheel scoops the ice up to the top front of the hopper where there is an outlet to the ice chute.

**Table of Contents**

Specifications/Limitations . . . . . page 2

Installation . . . . . page 3

Kits . . . . . page 5

Final Check List/Initial Start Up/Electrical Sequence . . . . . page 7

Cleaning . . . . . page 8

Service Diagnosis . . . . . page 9

Removal and Replacement . . . . . page 10

Parts lists and wiring diagrams are located in the center of this manual, printed on yellow paper.

Note the warning symbol where it appears in this manual. It is an alert for important safety information on a hazard that might cause serious injury.



Keep this manual for future reference.

This manual was printed on recycled paper.

# SLD150

## Specifications:

### Limitations:

- Must meet the same limitations as the cuber installed on top of it:
  - 55<sup>0</sup>F. air minimum,
  - 100<sup>0</sup>F. air maximum.
- Must be installed indoors.
- Must allow space to the right for air intake when using air cooled ice machine.
- Compatible only with Scotsman SLE300 or SLE400 Slim Line® brand models.
- Must allow space for utility connections at the back.
- Must have a drain.

*Top View of SLD150*

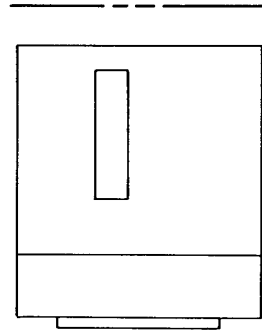

### Optional Kits (for SLD150-1B) Include:

Coin Mechanism, kit number KSLDC2

Key Mechanism, kit number KSLDK2

All kits are field installed.

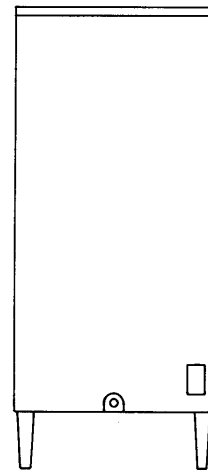
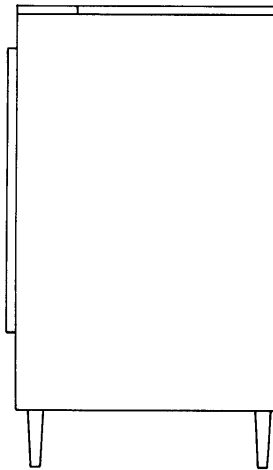
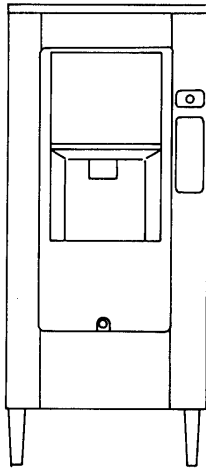

Model	Dimensions (with legs) W x D x H	Basic Electrical	Finish	Ice Storage Capacity	Max Fuse Size	Min Circuit Ampacity
SLD150S-1B	22" x 32" x 50"	115/60/1	Stainless Steel	90 lb.	15	2.9

## Installation: General

After the carton has been removed from the dispenser, the legs may be installed.

Place flat portions of the carton on the floor behind the dispenser and lay the dispenser down on its back.

Thread the legs into the base of the dispenser. Be sure that the legs are screwed in all the way. Turn the leg levelers in all the way.

Move the dispenser to an upright position and set it in the location where it will be installed. Note where drain lines and electrical connections will be made.

### Drain:

The dispenser has a 3/4" FPT drain fitting at the bottom center of the back panel. Connect 3/4" rigid tubing to this connection, a vent is recommended for most installations. Route the drain tubing to the building drain. Follow all applicable plumbing codes.

Because the drain tubing will be very cold, insulation is recommended.

### Electrical:

There is an electrical junction box on the lower back panel

Make the electrical connections there. Follow all applicable electrical codes. Use a licensed electrician.

The dispenser must be installed so that it is a separate piece of equipment from the ice machine. The drains and electrical supply must be separate.

#### Note

Remove any packing material from inside the storage bin. Retain keys for later use. Check that gasket tape is on the top outside edge of the dispenser where the ice machine will rest.

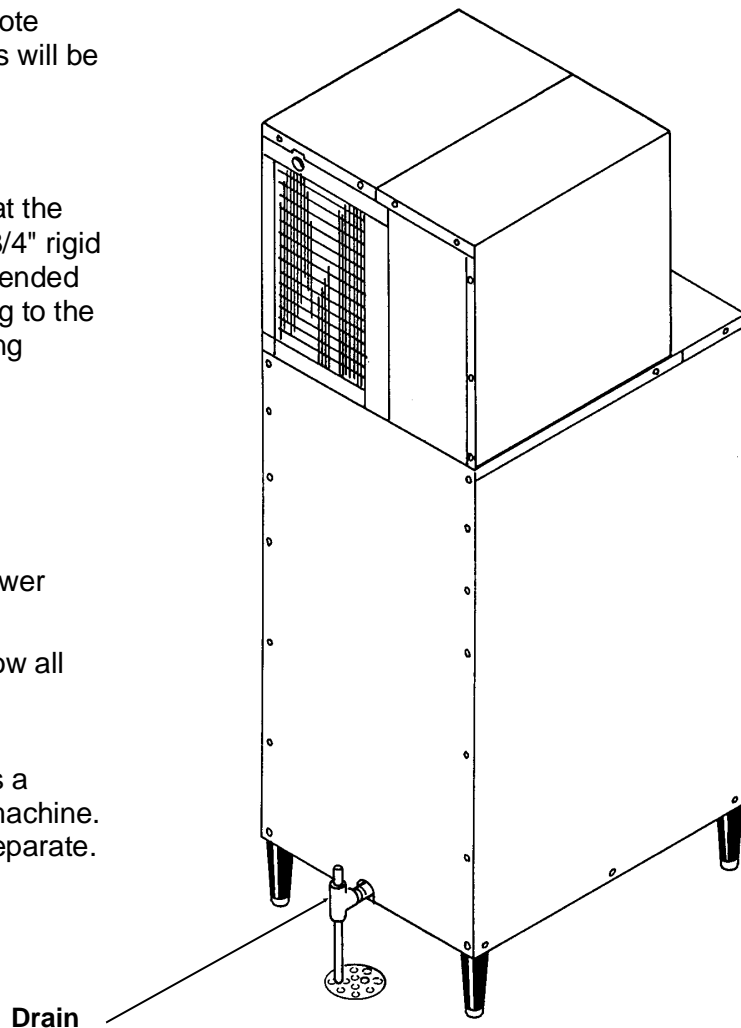

# SLD150

## Installation: Ice Machine

Check that gasket tape has been placed at the outside edge of the dispenser top.

Place corner posts from the carton on top of the dispenser, at the left and right front corners.

Locate bin thermostat bracket entrance hole, its found at the right side of the hole in the top of the dispenser. Make sure the hole is open.

Place the ice machine onto the dispenser. The ice machine is heavy, use of a mechanical hoist is recommended.

The ice machine should be tilted up slightly. Uncoil about 18" of bin thermostat capillary tube.

Push the end of the capillary tube thru the plastic tube located to the left of the compressor.

Observe the tube as it pushes down out of the base. Adjust the position of the ice machine so that the capillary tube enters the hole for the dispenser's bin thermostat bracket.

Carefully remove cardboard supports and allow ice machine to rest on dispenser gasket.

Caution: Bin thermostat capillary tube must not be kinked or broken during installation.

Follow all instructions for installation of the ice machine.

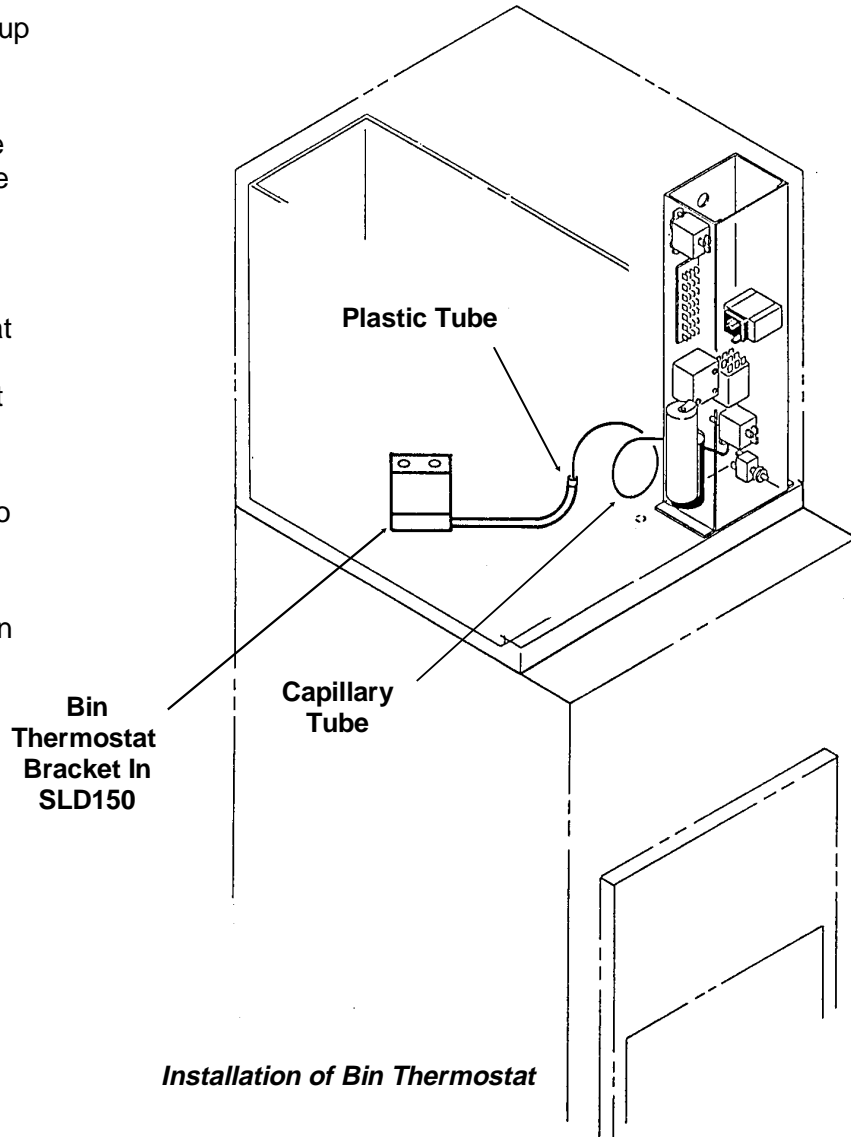

## Kits: Coin Mechanism (KSLDC2)

A kit is available to install a coin mechanism, and another kit is available to install a room key mechanism. Both come with detailed instructions, summarized here:

Coin Mechanism, install after ice machine has been operating:

1. Disconnect electrical power.

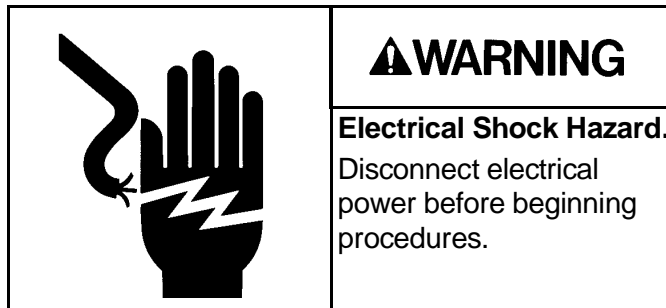

2. Locate key, unlock and remove sink. Then remove the top front brace and control box cover.
4. Remove all the wires from the push button switch.
5. Remove the nuts that secure the push button cover to the dispenser and remove the cover.
6. Remove the screws that hold the push button switch to the dispenser and remove the push button switch.
7. Install the small cover plate from the kit.
8. Remove cover plate on right side of front panel, below push button switch; use 5/16" nut driver.
9. Install the mounting plate from the kit using the nuts from the kit.
10. Secure the coin mechanism to the mounting plate from the inside of the dispenser. Use the screws, flat washers and lockwashers from the kit.
11. Remove the cover from the control box.
12. Remove the timer mechanism from the kit and install it in the control box.
13. Remove wires numbered 8 and 9 from the control box, they will be replaced by new wires from the kit marked 8 and 9.
14. Install the new wires, following the wiring diagram from the kit.
15. Reconnect the electrical power supply to the machine.
16. Place a container in the drop zone of the dispenser. Place a quarter in the slide of the coin

mechanism and hold in the safety interlock switch. Push the slide in and release it. The dispenser should dispense ice into the container.

17. Check if the proper amount of ice was dispensed.

If more ice is needed:

- Increase the time by turning the timer adjustment dial clockwise.

If less ice is needed:

- Decrease the time by turning the timer adjustment dial counter clockwise.

The initial setting should be 4 on the dial, or 8 seconds. Each segment equals 2 seconds.

**Important: Disconnect the power supply when adjusting the timer.**

18. Place new schematic over the old one.
19. Install the coin box.
19. Reconnect power to dispenser.
20. Replace control box cover.
21. Replace sink.
22. Check operation of coin box and key lock. After everything is operating, give key to user.

**Control Box Layout**

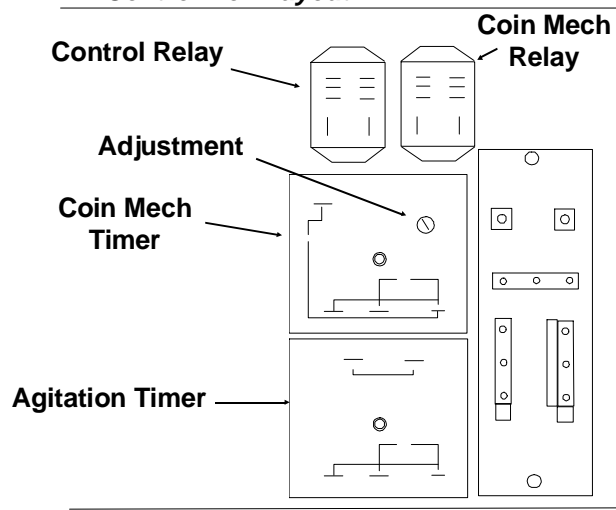

### Electrical Sequence

1. Coin switch closes, connecting power to timer.
2. Timer closes internal contacts, connecting power to gearmotor (and door solenoid if -1B)
3. Gearmotor rotates dispense wheel until internal timer contacts (AND cam switch contacts if -1) open. The time of rotation (and amount of ice dispensed) is determined by the timer.

# SLD150

## Key Kit Installation: (KSLDK2)

---

1. Disconnect electrical power

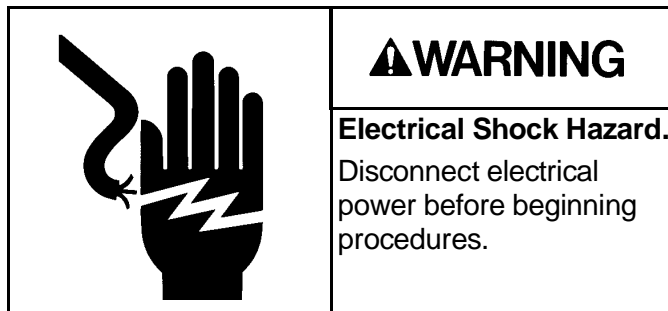

2. Remove sink and drain pan.

3. Remove cover.

4. Remove control box cover

5. From kit, locate brass fitting. Obtain typical door lock cylinder from the motel/hotel.

6. Insert cylinder into brass fitting (most cylinders will fit). Mark place where cylinder sticks out past brass fitting. Cut off excess cylinder.

7. Insert cylinder into hole on plate in kit. Place switch mounting bracket behind cover plate and over fitting, with the switch below the fitting. Using the locknut provided, fasten the fitting in place with the flats vertical.

8. Place the cylinder in the brass fitting, and secure to the fitting with the set screw.

9. Push hotel/motel key into the cylinder and adjust lever of micro switch so the switch closes when the key is pushed all the way in.

10. Install plate and switch assembly into dispenser. Secure with nuts removed from original plate.

11. Remove wire #8 from normally open terminal of the dispenser switch and reconnect it to the normally open terminal of the room key microswitch.

12. Disconnect wire #9 from the normally open terminal of the dispense switch and connect it to the normally open terminal of the room key switch.

13. Use wire #6 from kit, and connect the normally open post of the dispense switch and common of the room key switch

Install control box cover.

Replace drain pan and sink.

Reconnect power and check vending. Pushing key in and holding vend button down should start vend.

## Final Check List/Initial Start Up

1. Check that electrical power has been supplied.
2. Check that a drain, separate from the ice machine, insulated and made of rigid tubing, has been connected to the dispenser.
3. Check that the ice machine has been properly installed per the ice machines installation directions.
4. Check that the ice machine/dispenser assembly is level front to back and left to right.
5. Check that optional kits, if any, have been correctly installed.
6. Check that the sink key, and coin box key if used, are available.

### To Start:

1. Connect electrical power.
2. Go thru ice machine start up procedures. Let ice machine make two harvests.
3. Push vend switch button in.
4. Rotor should rotate 1/4 turn and stop.
5. Ice will be dispensed from ice chute.
6. Remove sink, and check drain area for leaks. If none, replace sink.
7. Fill out the warranty registration form and place it in the mail.
8. Give the operator the key(s) and instructions on the operation and maintenance of the product. Check that the operator knows who to call for service, and has the product/service manuals for the machines.

### Electrical Sequence

Pushing the vend button closes a contact to the gear motor (and to the ice door solenoid of SLD150-1B models).

SLD150-1 model: When the gearmotor begins to turn, the cam switch on the gearmotor closes, so that the vend switch may be released without interrupting the vending, until the cam has moved 1/4 turn. The cam switch then opens to terminate the vend.

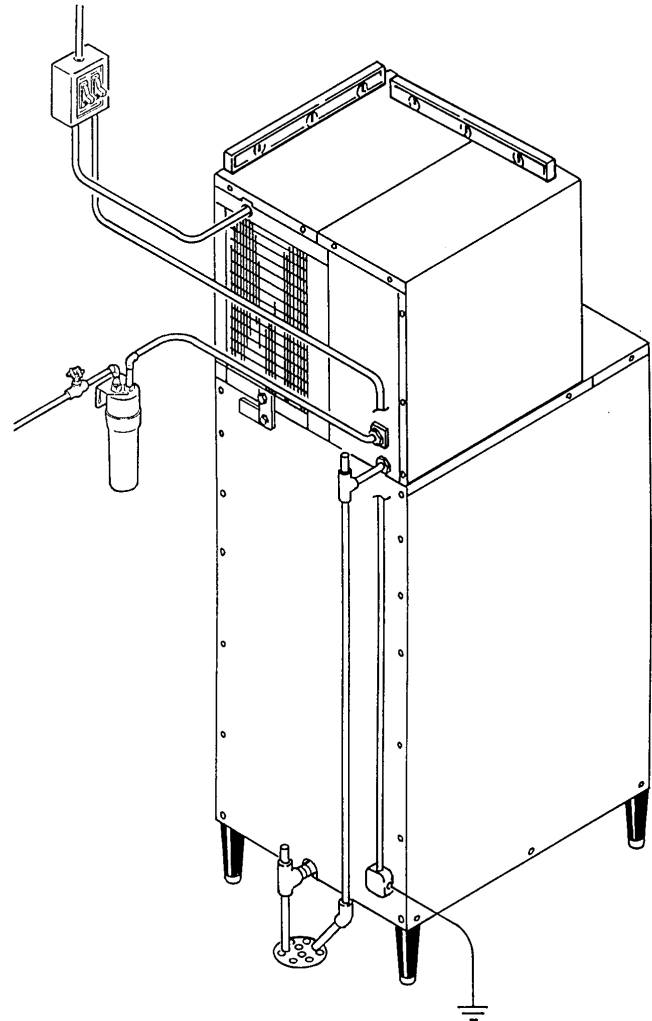

SLD150-1B model: The gearmotor and ice door solenoid will have power and the dispenser will continue to operate as long as the dispense switch is pushed in. This model also has a agitation cycle of 3 seconds every 2 hours. The solenoid does not engage during agitation and no ice is dispensed.

# SLD150

## Operational Schematic

---

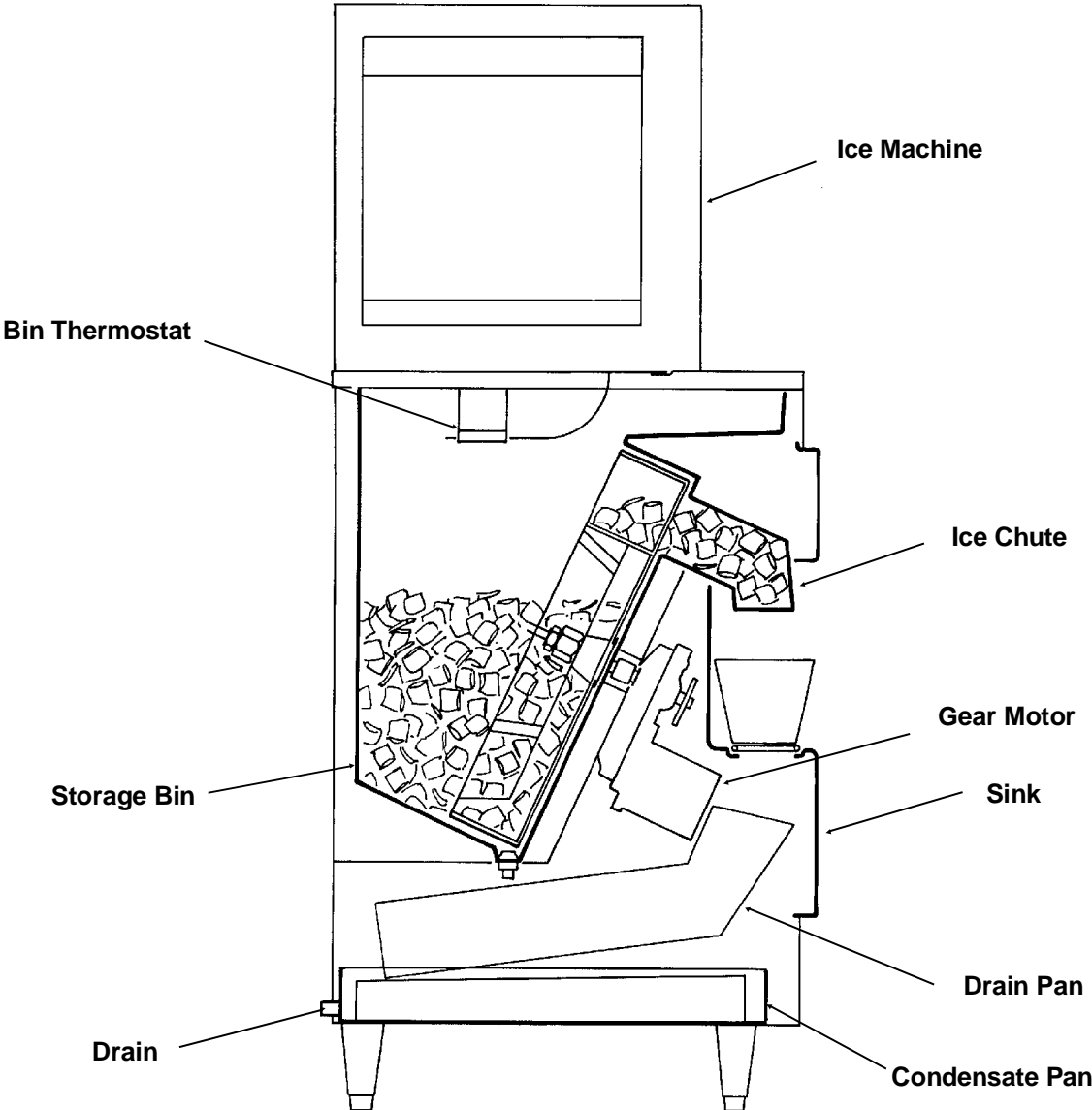



## Cleaning

### General Care and Cleaning

Periodically inspect and clean the ice dispenser to keep it operating at peak performance.

Wash the outside of the dispenser with warm water and soap. Rinse off and wipe dry.

### Cleaning and Sanitizing of the Ice Storage Bin:

The minerals, chlorine and other impurities in the water are rejected from the water during the freeze cycle of the ice machine. These minerals will collect in the storage bin. The ice storage bin should be cleaned and sanitized every 90 days.

1. Remove all of the ice stored inside the dispenser bin and shut off the ice maker.

2. Disconnect electrical power

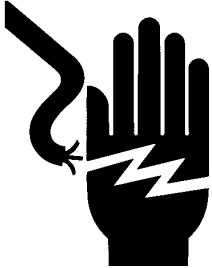
	<p><b>⚠ WARNING</b></p>
	<p><b>Electrical Shock Hazard.</b> Disconnect electrical power before beginning procedures.</p>

	<p><b>⚠ WARNING</b></p>
	<p><b>Moving parts in bin will cause injury if hands are in the way.</b> Disconnect electrical power before beginning procedures.</p>

3. Locate key and remove sink.

4. Remove top front panel (in front of ice machine).

5. Remove the front top panel (above ice chute).

6. Reach into the opening, locate the large nut securing the wheel to the drive shaft. Remove the nut.

7. Pull the wheel off the drive shaft and leave it in the dispenser.

8. Mix a solution of 5 ounces of ice machine cleaner to 1 gallon of warm (95°F.-115°F.) water.

Wash the entire bin area and the delivery area. Use a clean brush or cloth.

9. Rinse all areas washed with clean, fresh water.

10. Using the ice machine cleaning solution, clean the ice grill, sink, and water pan. Rinse these parts with clean, fresh water.

11. To sanitize: Use a locally approved sanitizer. A possible sanitizer: Mix a solution of ice machine sanitizer and water: 1 ounce of household bleach to 2 gallons of (95°F.-115°F.) water. Wash all interior surfaces and the wheel with the sanitizer solution. Use a clean cloth.

**Scotsman Ice Machine Cleaner contains acids. These compounds may cause burns.**

If swallowed, DO NOT induce vomiting. Give large amounts of water or milk. Call Physician immediately. In case of external contact, flush with water.

**KEEP OUT OF THE REACH OF CHILDREN.**

**⚠ WARNING**

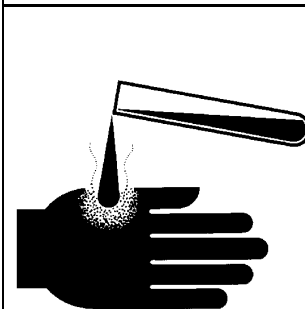

12. Allow the parts to air dry.

13. Reassemble wheel and large nut onto drive shaft.

14. Replace all panels.

15. Reconnect power, be sure ice machine is switched back on.

# SLD150

## Service Diagnosis

---

<b>PROBLEM</b>	<b>POSSIBLE CAUSE</b>	<b>PROBABLE FIX</b>
Does not vend	No ice	Check ice machine
	No power	Check power supply
	Vend switch open	Check/replace vend switch
	Sink interlock switch open	Check/replace sink interlock switch
	Ice jams in chute	Machine is not level
	Front panel not on all the way	Reinstall panel
	Gearmotor open	Check/replace gearmotor
	Cam switch open (SLD150-1)	Check/replace cam switch Adjust cam switch to close when on high part of cam
	Ice door does not open (SLD150-1B)	Check for power to solenoid. Check linkage from solenoid to door
	Drive shaft broken	Check/replace drive shaft.
Coin Mechanism	Does not vend, no ice	Check the above, plus coin switch
		Check wiring
		Check timer
Leaks water	Bin drain leaks	Check bin drain connections and fittings
		Check for clogged bin drain tubing

## Removal and Replacement

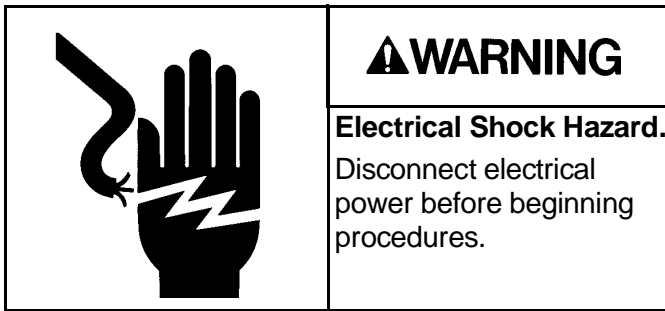
**Gear Motor**

1. Disconnect electrical power
2. Locate key and remove sink.
3. Disconnect wires at gearmotor
4. Mark position of cam switch bracket, and remove bracket with cam switch from gearmotor.
5. Remove 4 nuts securing gearmotor base o cabinet.
6. Pull gearmotor down and out of cabinet.
7. Remove gearmotor from base.

Reverse to reassemble.

**Drive Shaft**

1. Remove all of the ice stored inside the dispenser bin and shut off the ice maker.
2. Disconnect electrical power
3. Locate key and remove sink.
4. Remove top front panel (in front of ice machine).
5. Remove the front top panel (above ice chute).
6. Reach into the opening, locate the large nut securing the wheel to the drive shaft. Remove the nut.
7. Disconnect wires at gearmotor.
8. Mark position of cam switch bracket and remove bracket with cam switch from gearmotor.
9. Remove 4 nuts securing gearmotor to cabinet.
10. Pull gearmotor down and out of cabinet.
11. Remove six cap screws holding drive shaft housing to cabinet.
12. Pull drive shaft housing from the bin.
13. Remove snap ring from end of drive shaft, and tap shaft out of bearings with plastic headed or dead blow hammer.
14. Reverse to reassemble.

**Dispense Wheel**

1. Remove all of the ice stored inside the dispenser bin and shut off the ice maker.
2. Disconnect electrical power.
3. Remove ice machine from dispenser.
4. Remove large dispenser top panel.
5. Reach into the opening, locate the large nut securing the wheel to the drive shaft. Remove the nut.
6. Pull the wheel off the drive shaft and remove it from the dispenser.

Reverse to reassemble.