

Introduction:

This manual covers the assembly, installation, start up, operation and maintenance of the 600, 800 and 1000 remote low side cuber systems.

Table of Contents

Configuration:	Page 2	Controller Operation	Page 27
Technical Specifications	Page 3	Initial Start Up	Page 28
Model Number Locations	Page 4	Purge Adjustment	Page 29
Cabinet Drawings, Ice Making System	Page 5	System Operation:	Page 30
Cabinet Drawings, Compressor Package and Condensers	Page 6	Refrigeration Details:	Page 31
Proper Combinations:	Page 7	Technicians Only: Freeze Cycle Sequence of Operation	Page 32
Create the System	Page 8	Technicians Only: Harvest Cycle Sequence of Operation	Page 33
System Examples	Page 9	Power and Water Interruptions	Page 34
System Examples	Page 10	Sanitation and Cleaning	Page 35
Place Remote System	Page 11	Other Maintenance	Page 36
System Location	Page 12	Tight Installation Access	Page 37
Route Tubing	Page 13	Water Distributors	Page 38
Ice Making Section	Page 14	Ice Sensors	Page 39
Compressor Package	Page 15	Water Level Sensor Maintenance	Page 40
Condensing Section Assembly	Page 16	Service Diagnosis	Page 41
Condensing Section Assembly: ER2C6810	Page 17	Service Diagnosis	Page 42
Condensing Section Assembly	Page 18	Service Diagnosis	Page 43
Ice making section:	Page 19	Controller Features & Last Error Recall	Page 44
Water and Drain	Page 20	Operational Characteristics 600 lb system	Page 45
Water and Drain	Page 21	Operational Characteristics 800 lb system	Page 46
Water and Drain	Page 22	Operational Characteristics 1000 lb system	Page 47
Ice Making Section Set Up	Page 23	Refrigeration System Service	Page 48
Coupling Connections:	Page 24		
Condensing Unit Connections	Page 25		
Final Placement	Page 26		

Prodigy Eclipse™ 600, 800, 1000

Configuration

A remote low side cuber system includes several sub systems: an ice making section, a remote compressor package, and a remote air cooled condenser. Additionally, there are several models of each sub-system and this manual covers all of them.

The ice making sections are designed for use indoors in a controlled environment. The remote compressor packages and condensers are designed to operate outdoors. Each sub-system has limits for power, water and temperature.

Operational Limitations:

	Minimum	Maximum
Air Temp (IMS)	50°F	100°F.
Air Temp (CU)	-20°F.	120°F.
Water Temp	40°F.	100°F.
Water Pressure	20 psi	80 psi
Voltage (IMS)	104	126
Voltage (CU)	198	253

IMS = Ice Making Section, CU= Condensing Unit

System Information

System Size	Condensing Unit (CU)				Ice Making Section (IMS)	
	Compressor Package		Condenser		Model	Electrical
	Model	Electrical	Model*	Electrical		
600**	C0600CP-32A	208-230/60/1	ERC680-32A	208-230/60/1	EH222SL-1	115/60/1
800	C0800CP-32A	208-230/60/1	ERC680-32A	208-230/60/1	EH222SL-1 OR EH222ML-1	115/60/1
	C0800CP-3A	208-230/60/3				
1000	C1410CP-32A	208-230/60/1	ERC1086-32A	208-230/60/1	EH222SL-1 OR EH222ML-1	115/60/1
	C1410CP-3A	208-230/60/3				

Notes: Voltage Codes are at the end of the model number. Codes read Voltage/Hertz/Phase. Those related to these products include:

- 1 = 115/60/1
- 3 = 208-230/60/3
- 32 = 208-230/60/1

Do Not operate the machine in conditions beyond these limitations. Doing so will void the warranty.

Scotsman ice systems are designed and manufactured with the highest regard for safety and performance. They meet or exceed the standards of UL and NSF.

Scotsman assumes no liability of responsibility of any kind for products manufactured by Scotsman that have been altered in any way, including the use of any part and/or other components not specifically approved by Scotsman.

Scotsman reserves the right to make design changes and/or improvements at any time.

Specifications and design are subject to change without notice.

Warranty

Refer to the warranty coverage in effect when the equipment was sold. Warranty statements are included with each product.

Systems:

Each sub-system is a separate entity that carries its own model and serial number. They must be combined to create a remote cuber low side system.

*ER2C6810-32 is a two circuit remote condenser and can be used with any combination of a 600 or 800 or 1000 system.

** Do NOT use EH222ML in 600 size systems.

Pre-charged tubing kits are required to interconnect the IMS to the CP.

Interconnecting 24 volt control wire ships with the CP unit.

Prodigy Eclipse™ 600, 800, 1000

Technical Specifications

Ice Making Section (IMS)

Model	Voltage	Minimum Circuit Ampacity	Max Fuse Size	Cabinet Size	Weight (lb)
EH222SL-1	115/60/1	3	15	22"w x 16.5"d x 29" h	90
EH222ML-1	115/60/1	3	15	same	90

Compressor Package

Model	Voltage	Contains Headmaster?	Minimum Circuit Ampacity	Max Fuse Size	Refrigerant Charge (R-404A)*	Cabinet Size	Weight (lb)
C0600CP-32	208-230/60/1	Yes	10	15	232	29 ¾"w x 18"d x 34 ½"h	165
C0600CP-3	208-230/60/3	Yes	7.1	15	232	same	165
C0800CP-32	208-230/60/1	Yes	14.8	20	232	same	180
C0800CP-3	208-230/60/3	Yes	10.58	15	232	same	180
C1410CP-32	208-230/60/1	Yes	16.45	30	272	same	180
C1410CP-3	208-230/60/3	Yes	12.58	20	272	same	180

* Includes entire system charge.

Condenser

Model	Voltage	Contains Headmaster?	Number of Circuits	Minimum Circuit Ampacity**	Max Fuse Size**	Cabinet Size, with legs	Weight (lb)
ERC680-32A	208-230/60/1	No	1	1.25	15	29 ¾"w x 28 5/8"d x 38 ½"h	95
ERC1086-32A	208-230/60/1	No	1	1.25	15	same	95
ER2C6810-32	208-230/60/1	No	2	1.9	15	29 ¾"w x 37 3/16"d x 38 ½"h	

** ERC condenser fan motor is powered from CP unit and the ERC's ampacity is included in CP unit numbers.

Note: The ERC680, ERC1086 and ERC26810 do NOT contain a headmaster. The headmaster is in the CP units.

Note: 75 feet of interconnecting control wire (24 volt) is included with the CP units.

Prodigy Eclipse™ 600, 800, 1000

Model Number Locations

Ice Making Section

The dataplate on the back of the ice machine contains the model number, serial number and electrical data.

A second plate, located behind the front panel at the lower right front, also lists the model and serial numbers.

Compressor Package

The dataplate on the right side of the compressor package contains the model number, serial number, electrical data and system refrigerant charge.

A second plate, located behind the front panel in front of the compressor, also lists the model number, serial number and refrigerant charge.

Condenser

The dataplate lists the condenser's electrical information plus the model and serial numbers.

On the ERC680 and ERC1086 it is located on the side opposite the refrigeration connections.

On the ER2C6810 it is located on the inside of one of the leg panels.

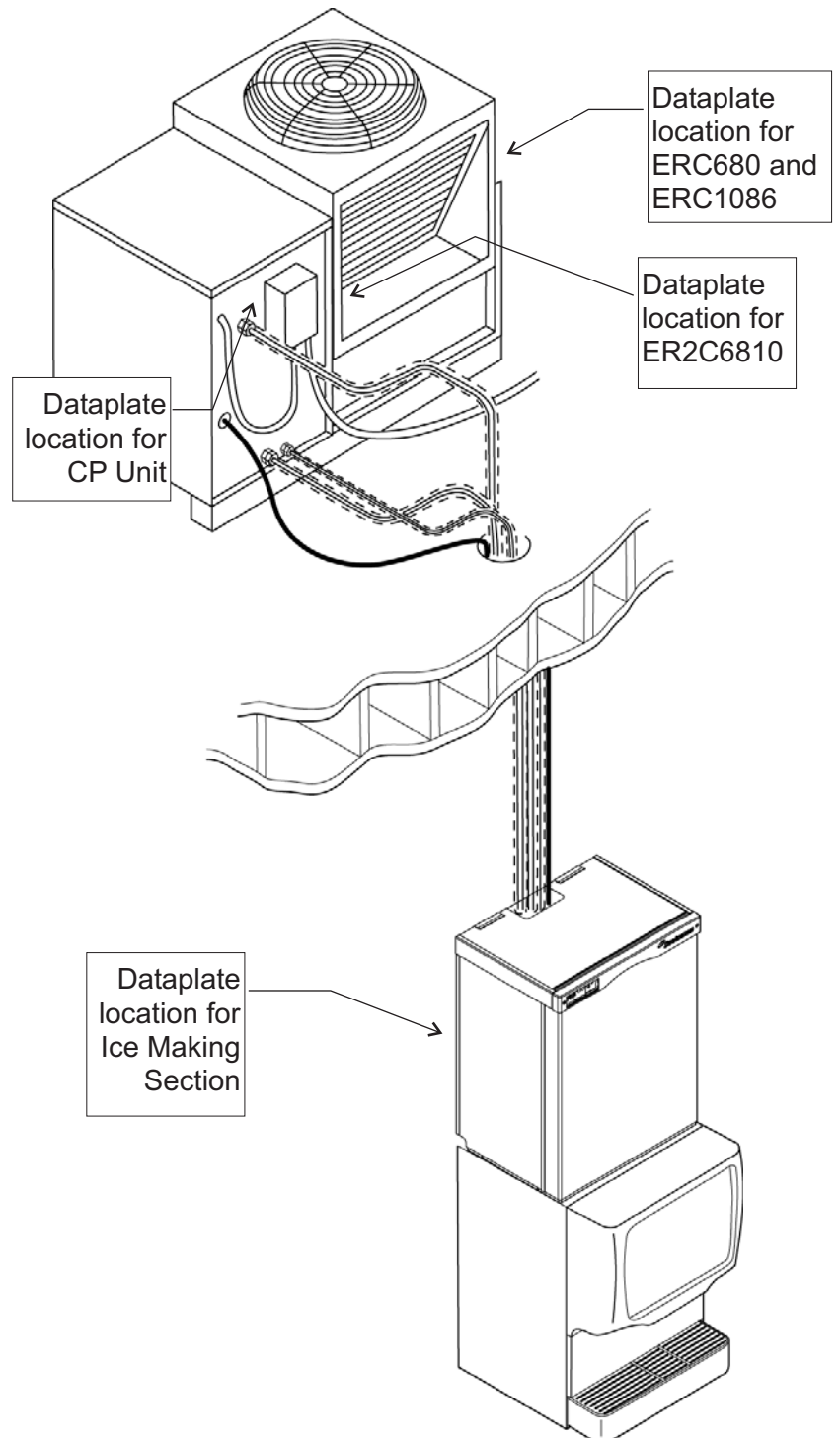

Prodigy Eclipse™ 600, 800, 1000

Cabinet Drawings, Ice Making System

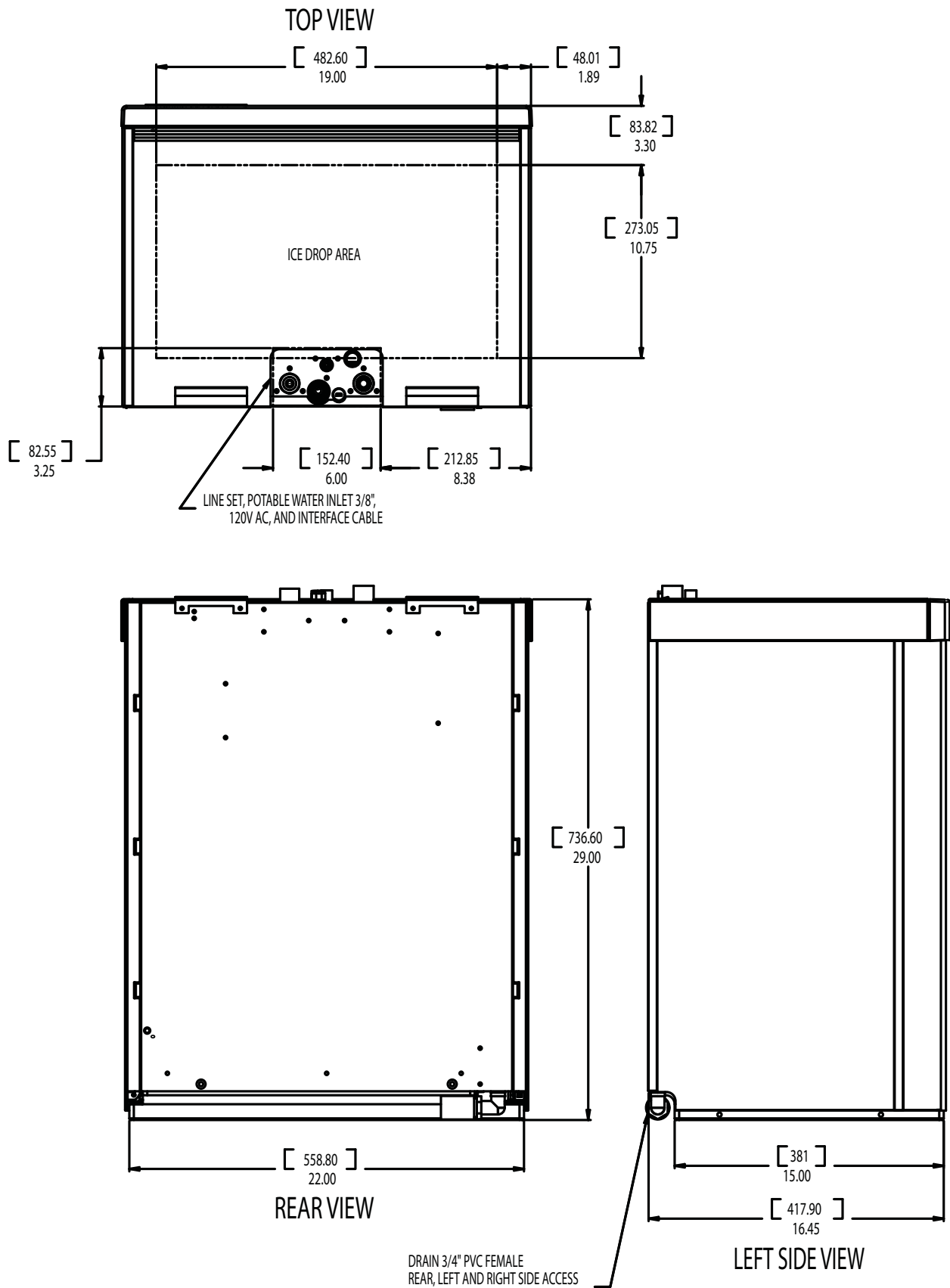

Prodigy Eclipse™ 600, 800, 1000

Cabinet Drawings, Compressor Package and Condensers

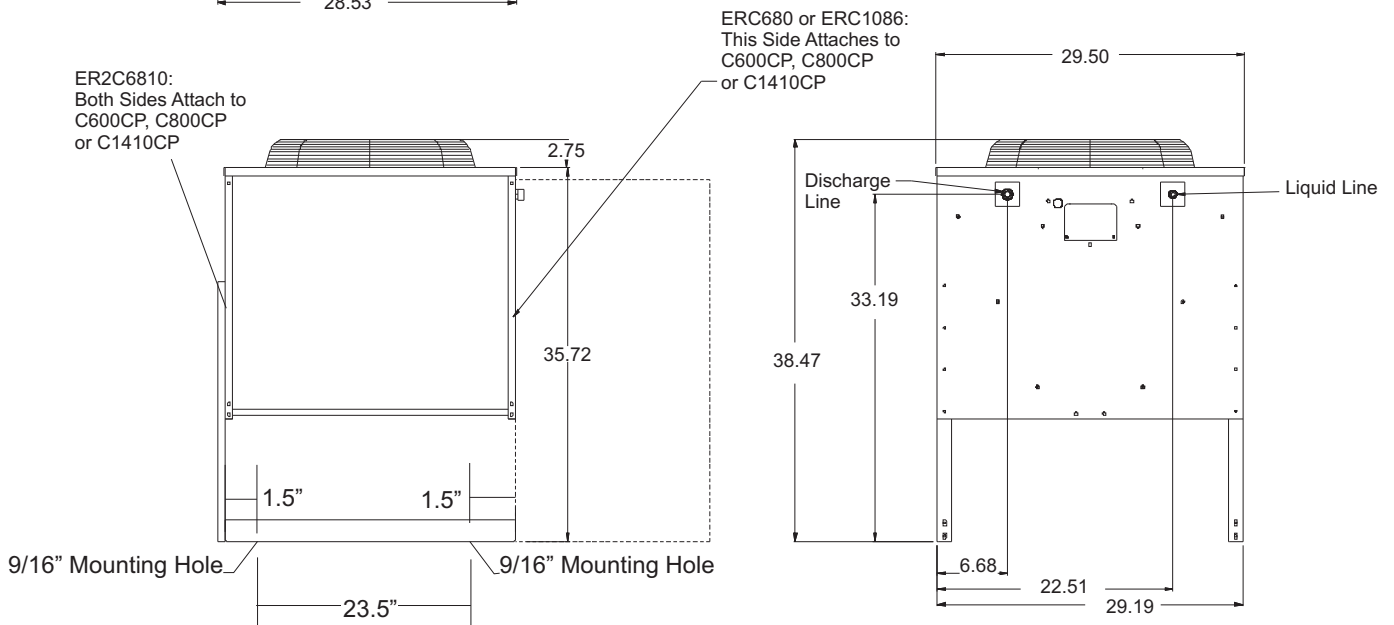
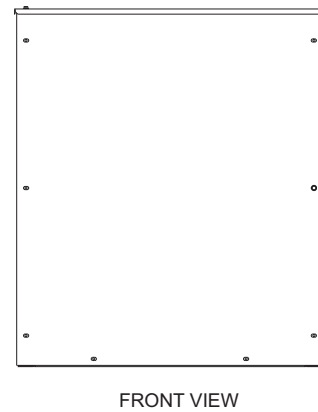
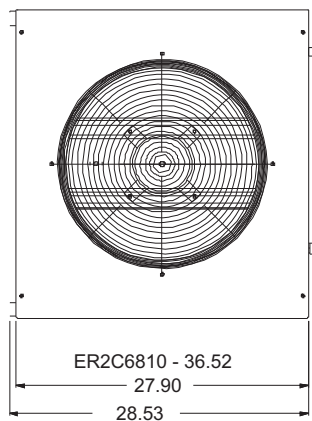
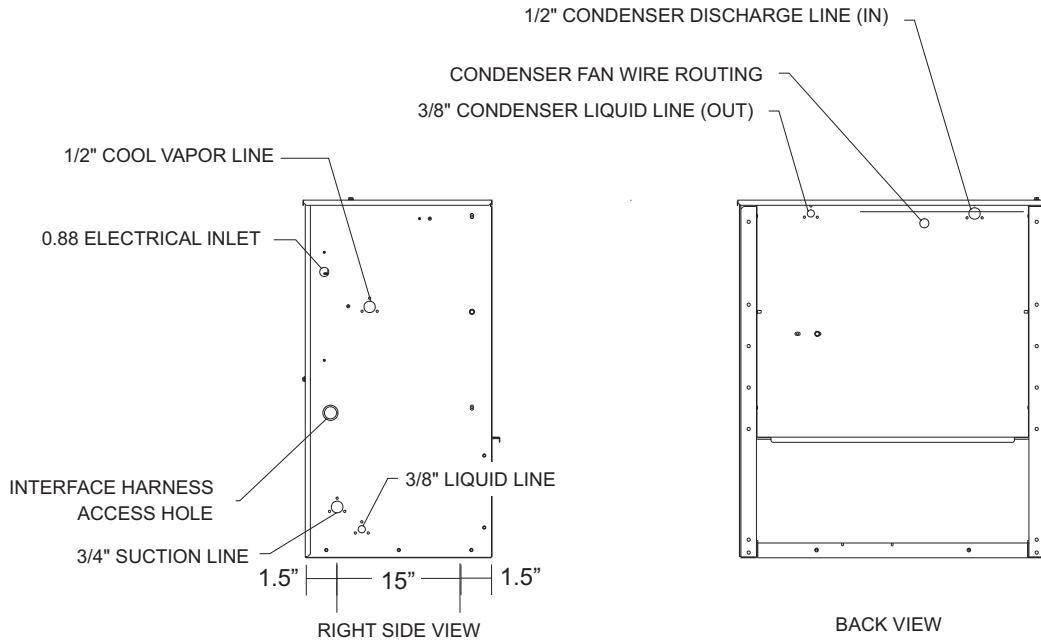

Proper Combinations:

The three sub systems are designed to be connected together in certain combinations to meet the user's needs:

Eclipse 600 System: EH222, C0600CP, ERC680*

Eclipse 800 System: EH222, C0800CP, ERC680*

Eclipse 1000 System: EH222, C1410CP, ERC1086*

*ERC680 or ERC1086 may be substituted for by an approved central condenser coil & fan (coil must be without headmaster - headmaster is part of C0600CP, C0800CP or C1410CP).

Note: The ice making section cannot be stacked vertically.

Accessories such as bin adapters and tubing kits are required to complete the installation.

Dispenser Adapter Kits:

- Cornelius ABS: **KBTABS**
- ED150: **KBT40**
- Scotsman ID150: **KBT40**
- Scotsman ID200 or ID250: **KBT41**
- HD22: **KBT35**
- HD30: **KBT32**

Bin Adapter Kits:

- B322S: **KBT31**
- B330P: **KBT32**
- B530P or B530S: **KBT32**
- B842S: **KBT33**
- B948S: **KBT34**

Tubing Kits:

- 20 foot: **3RTE20-EH**
- 35 foot: **3RTE35-EH**
- 50 foot: **3RTE50-EH**
- 75 foot: **3RTE75-EH**
- Suction Line Trap: **KSLT075**
- Interconnecting Tubing to Approved Rack Condenser Coil: **RTE10**
- Line end kit: **KTE6-EH**

Items required for installation:

- Ice making section
- Compressor Package (includes interconnecting control system wire)
- Remote condenser **or** approved rack coil w/tubing kit
- 20', 35', 50' or 75' triple line set (liquid, vapor and suction)
- Bin or dispenser adapter

Special Considerations

The ice making section's footprint is 22" wide by 16.5" deep. The refrigeration connections can be routed up or to the back. The drain may be routed out the back at any position left to right; it may also be routed to either side.

Water

Pure water does not exist. All water supplies contain some amounts of impurities, although potable water is, by definition, fit for human consumption. Because the contents of the water to an ice machine directly impact its performance, consideration should be given to improving the water's quality.

There are two ways water can contain impurities: in suspension or in solution. Suspended solids can be filtered out of the water. In solution or dissolved solids must be diluted or treated. Water filters are recommended to remove the suspended solids. Some filters or filter systems have treatment chemicals in them for treating the suspended solids.

This ice machine has an adjustment for the amount of water rinsed or purged. Water use adjustments are customer convenience adjustments; they are not factory defects and are not covered by warranty.

Prodigy Eclipse™ 600, 800, 1000

Create the System

Plan the installation. The system consists of four parts: the ice making section, the compressor package, the interconnecting tubing and the remote condenser. Of these, the biggest variable is the interconnecting tubing.

Tubing: The tubing consists of three pre-charged, insulated and sealed soft copper tubes. They each contain a small holding charge of R-404A. One tube, the liquid line, is 3/8" OD. The vapor tube is 1/2" OD and the suction tube is 3/4" OD. A site inspection will determine what length of tubing is required for the installation.

Excess tubing must be either shortened at the job site (recovering the holding charge, purging with nitrogen when brazing and evacuating to 50 microns) or coiled up inside the building. Coil must be in a downward spiral.

Installations with greater than 20 feet of vertical lift between ice machine and the compressor require a suction line trap. The suction line requires careful handling and large radius bends to prevent kinking.

Roof mounting: To make installation easier the compressor and condenser are designed to be assembled together on the roof. Some installations will require the use of a hoist to lift the components to the roof.

Pad mounting: The compressor and condenser may be located below the ice making section, up to a limit of 15 feet.

Distance from unit: Limited to the length of the available pre-charged tubing.

Elevation: CP unit limited to 35 feet above the ice making section.

Compressor package: Electrical power must be supplied to the compressor package. The remote condenser fan motor takes its power from the compressor package.

Ice making section location and attachment: The unique footprint of the EH222 requires adapter kits to allow placement on dispensers and bins. The remote tubing connections are at the top of the machine, and connections should not be made until the machine is nearly in its final installed position. The 115/60 Hz ice making section is cord connected and requires an outlet within 6 feet of the installation.

Interconnecting wires: An interconnecting wire harness is included with the CP unit. One end plugs into the ice making section and the other into the compressor package. The system will NOT operate without this harness.

Exposed tubing: Minimize the amount of tubing exposed outdoors.

Confirm Component Availability:

- EH222
- C0600CP or C0800CP or C1410CP
- ERC680 or ERC1086 or ER2C6810 unless connecting to an approved condenser coil.

Note: Only these condensers may be used. They do NOT contain a headmaster valve. That valve is in the Compressor Package. **Do NOT use any other Scotsman condenser.** Do NOT use these condensers on any other Scotsman remote product.

- Interconnecting tubing kit

Note: Check tubing integrity before assembly by attaching a refrigeration compound gauge onto one of each tube's schrader valves. If there is pressure, the tube is OK, if not it should be checked for damage and leaks.

- Bin or dispenser adapter

Prodigy Eclipse™ 600, 800, 1000

System Examples

The Eclipse system can be installed on a bin or dispenser. The CP unit can be installed on either a single circuit condenser, a two circuit condenser or onto a coil in a separate rack condenser.

Separate coils must be:

- Scotsman approved
- The correct size and capacity
- New or not have been part of a system that used mineral oil.

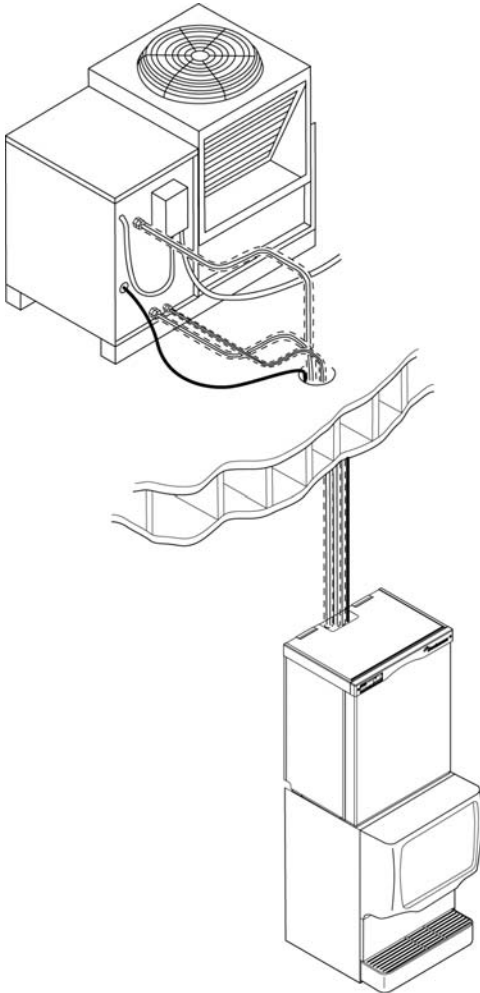

Single Circuit System

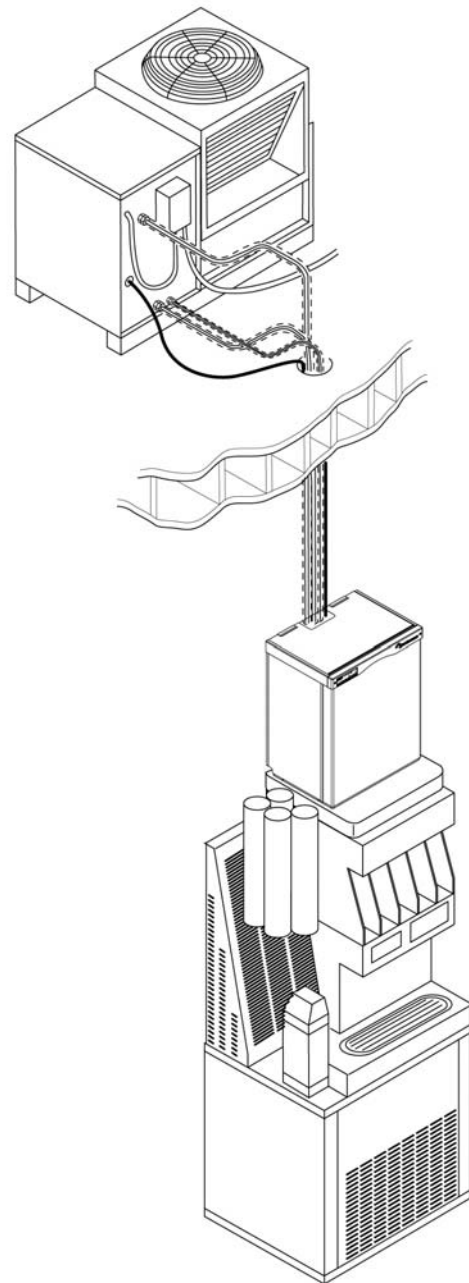

Single Circuit System on ABS Dispenser

Prodigy Eclipse™ 600, 800, 1000

System Examples

Single circuit systems use a single circuit condenser and one CP unit. Two circuit systems use a condenser with two circuits with a CP unit at each end.

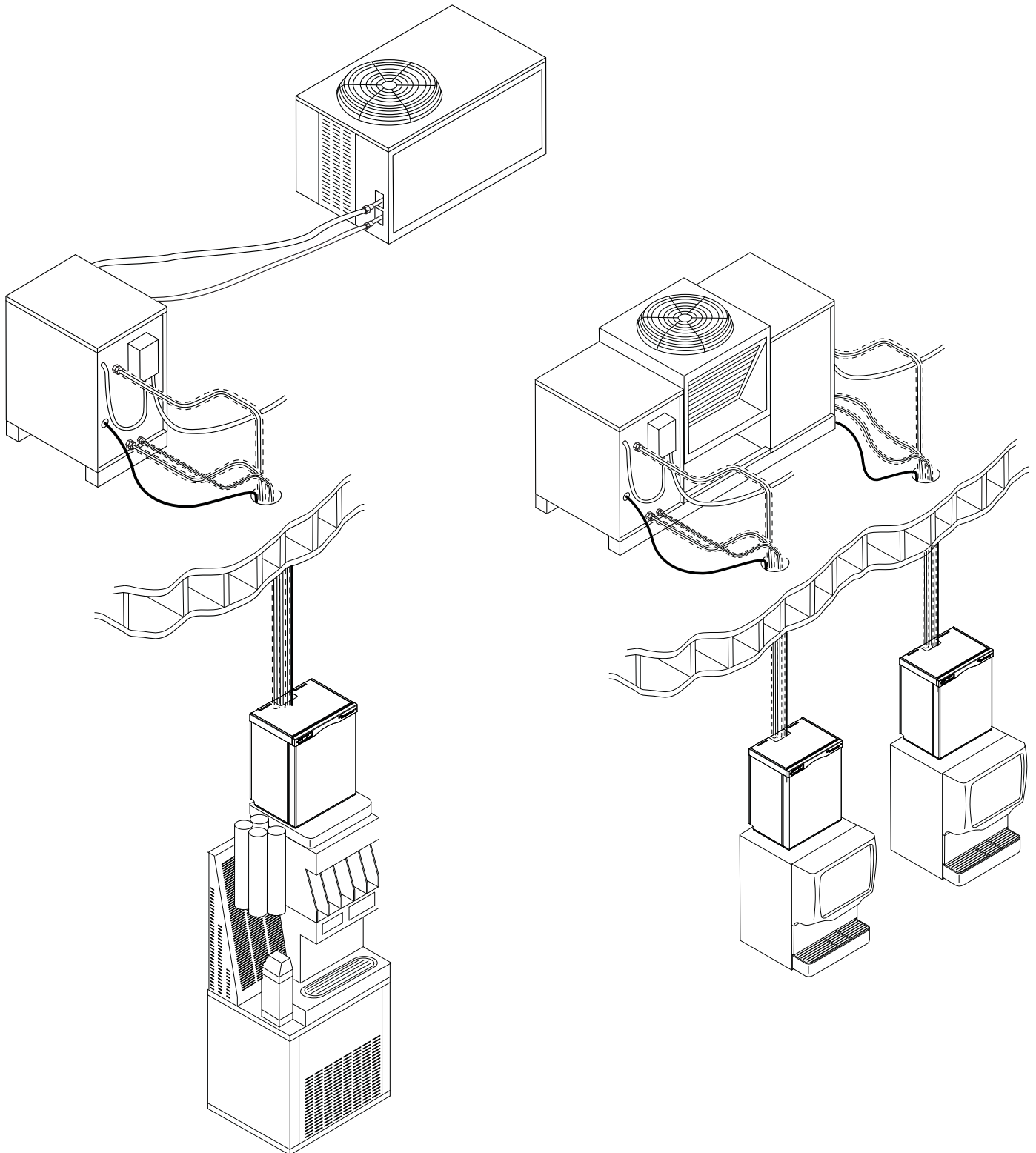

IMS on ABS Dispenser, CP Unit Connected to Approved Rack System

Two Circuit System

Place Remote System

Roof preparation

Most installations of this system will place the compressor package and condenser on the roof of a building. The roof must be physically stout enough to accept the load of the equipment and the roofing material must be prepared to prevent water leaks.

Follow local codes for the placement and attachment of the equipment.

Location

The condensing unit assembly requires unobstructed air flow to operate efficiently. A four foot space between each intake side and a wall or other cabinet is recommended.

Do not place where it will pick up hot discharged air from an air conditioner or other refrigeration system condensing unit.

Space must also be reserved for service on the compressor package. If using the two circuit condenser, save space for the second CP unit to be attached to the other end of the condenser.

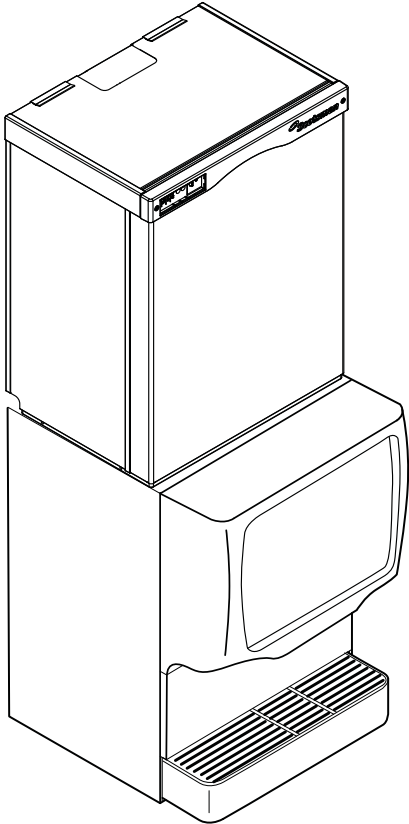

IMS Shown on Ice Dispenser

Roof Piercing:

The roof (or wall) must have a passage large enough for the three pre-charged, pre-bent tubes and the control wire to pass through. The minimum recommended size is 4" ID. In most areas the power supply may also pass through the same passage. If there isn't a passage one must be created. In most cases this must be done by a licensed and bonded roofer in order to maintain the roof's integrity.

Suggestions:

Hoist the compressor package and condenser to the roof in separate loads.

Note: In most cases a mechanical lift, boom truck or crane will be required to hoist the condensing unit components.

Assemble the compressor package to the condenser and mount both to either roof rails or pressure treated 4 x 4s.

Orient the assembled unit so that the unit's mounts are parallel to the pitch of the roof to allow water to drain freely.

Do NOT place the unit directly onto roof rock.

Prodigy Eclipse™ 600, 800, 1000

System Location

Limitations:

Distance: Limited to the maximum length of a single pre-charged tubing kit, 75 feet.

Condensing Unit Elevation over Ice Making Section: 35 feet.

Note: Elevations greater than 20 feet require installation of a suction line trap at the 20 foot mark.

Ice Making Section Elevation over Condensing Unit: 15 feet.

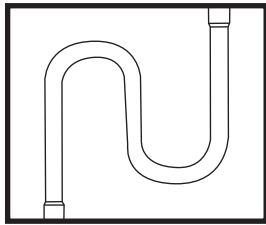

S-Trap

Line Routing:

- Allowed: One rise after a drop.
- Allowed: One drop after a rise.
- Not Allowed: More than one rise after a drop
- Not Allowed: More than one drop after a rise.

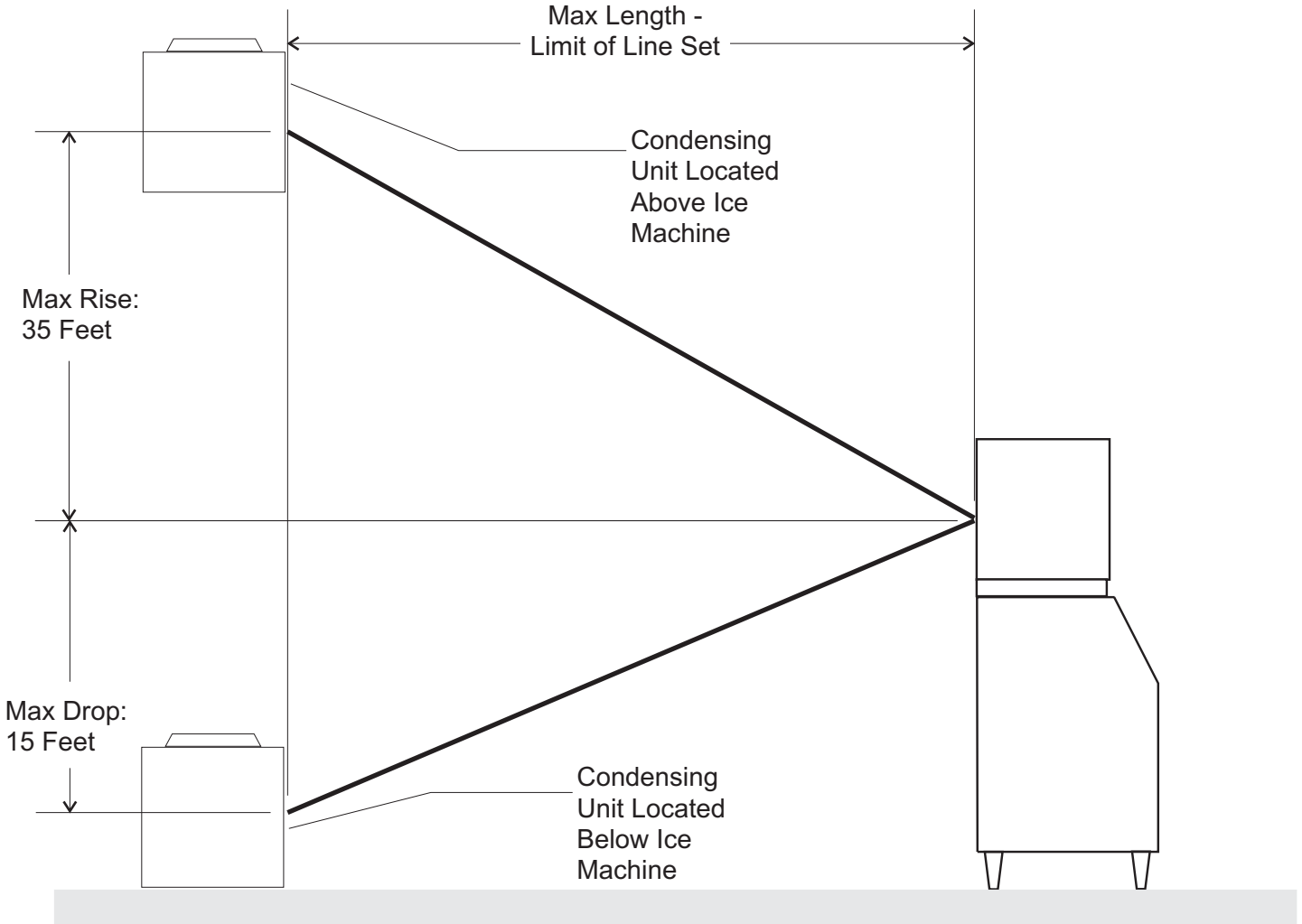

Condensing Unit Distance Schematic

Route Tubing

Scotsman's pre-charged tubing kits are pre-bent to fit the connection path at the ice making section.

- If the tubing is to be **routed up**, use the **straight ends**.

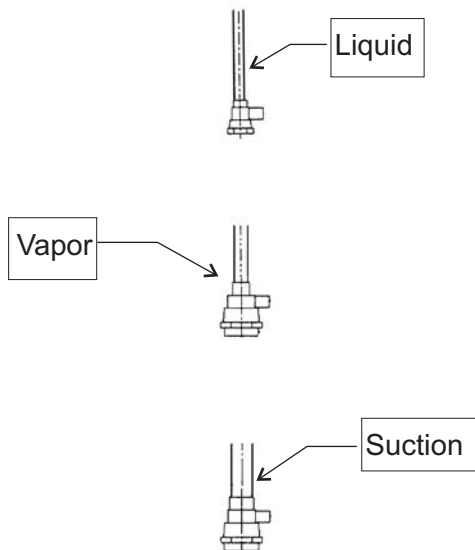

- If the tubing is to be **routed to the back**, use the ends with the **single 90 degree bends**.

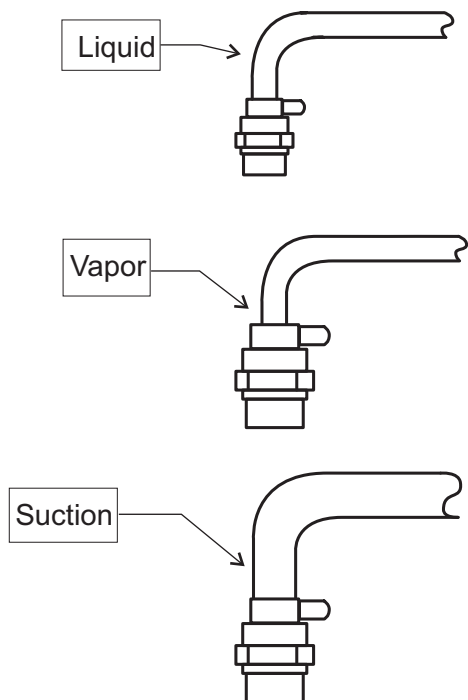

Note: Water inlet, power, interconnecting control wire and refrigerant connections are located at the back of the top panel. Drain may be routed back, left or right.

Select the correct end to send to the roof.

The method or technique used to route the tube is left to the installer. However, in many cases it is easier to position the tubing inside the building first, then feed the outside portion through the tubing passage (pitch pot). Installation of tubing will be easier if the suction line is run first, followed by the liquid and vapor lines. Use of two persons is suggested to prevent kinking of the tubing, long runs may require three people.

- Allow enough tubing to make large radius bends from the roof passage to the compressor unit. Do NOT leave excess tubing on the roof.
- If a trap must be installed, the suction line tubing must be cut apart to install it.
- Identify the ice machine end of the tubing. Each tube has one end formed to route through the hole in the unit's top.
- Tape the ends of the vapor and liquid line tubes together along with the interconnecting wire. Extend the end of the interconnecting wire about 2 feet beyond the end of the precharged tubes and then tape it back onto the tubes.
- Route the three tubes and the wire from the roof, or other entrance, to the ice making section's planned position. Avoid uncoiling and recoiling the tubing, as that can lead to kinks.
- Support long runs of tubing with hangers.
- Repair any tears in the tubing insulation, especially those on the suction line that are inside the building.

Shortening Tubing

The precharged tubing kits are available in a variety of lengths, they should only be shortened if absolutely necessary.

To Shorten Tubes:

1. Recover the 3 ounce R-404A holding charge from each tube.
2. Cut out the required length of tubing, do not cut the tubing right at the quick connects.
3. Attach nitrogen bottle to one quick connect and a hose with a depressor to the other end, purge nitrogen through each tube while brazing.
4. Remove nitrogen, evacuate to 50 microns.

Note: If tubes are connected to the IMS, evacuate the vapor & suction lines to get the entire system.

Prodigy Eclipse™ 600, 800, 1000

Ice Making Section

Major Components:

TXV -

Water Pump -

Water Level Sensor - signals water level to the controller

Controller - operates both the ice machine section and the compressor unit.

Drain Valve - opens to allow pump to drain reservoir

Water Inlet Valve - 1.25 GPM solenoid valve that opens to fill the reservoir

Liquid, Vapor and Suction Connections - where the pre-charged tubing kits connect to.

Drain Tube - internal vent eliminates need for external vent

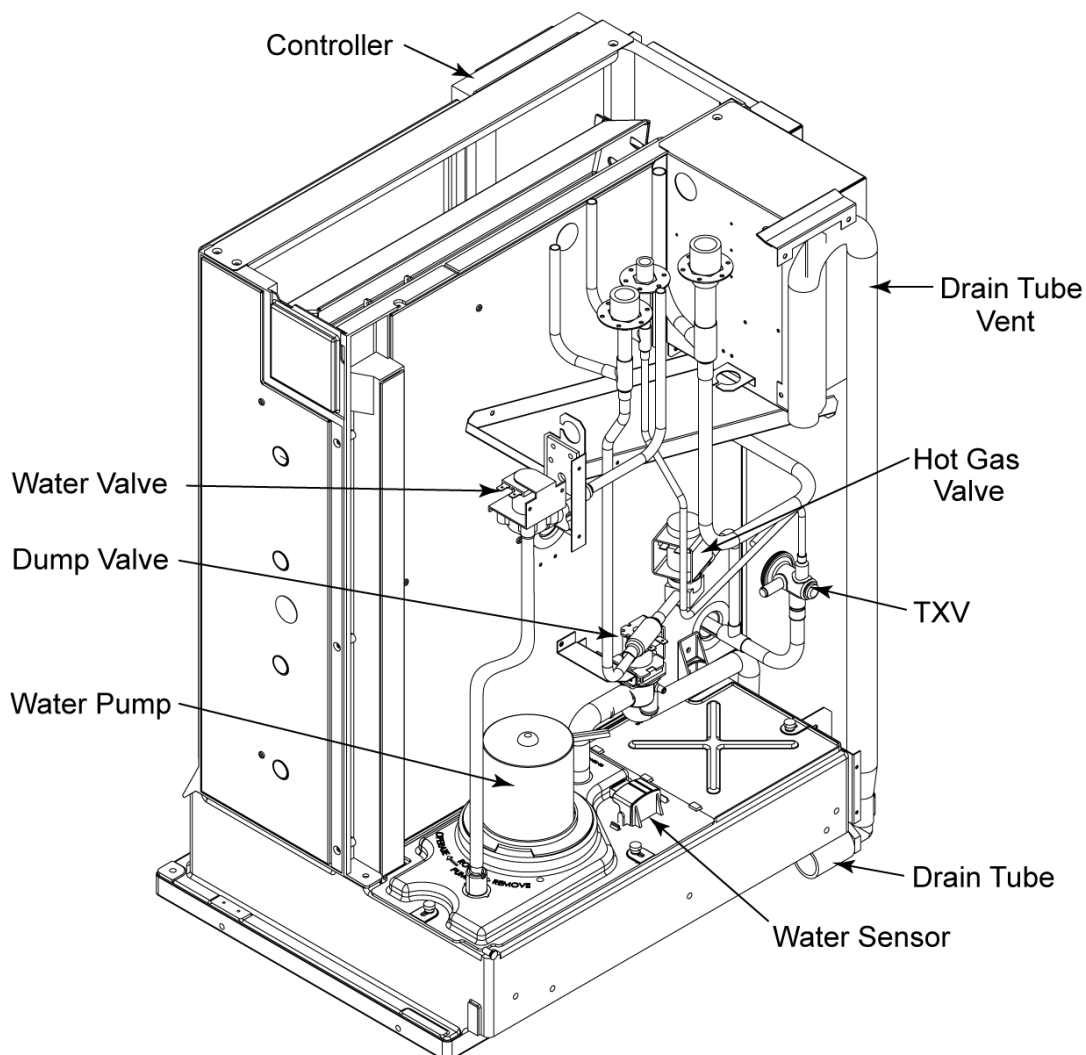

Component Location, Back View

Prodigy Eclipse™ 600, 800, 1000

Compressor Package

The compressor packages are similar in layout, they only differ in compressor and charge.

Major Components:

CPR Valve - limits refrigeration pressures inside the dome of the compressor.

Condenser By Pass Valve - opens during harvest to allow discharge gas to flow to the vapor line.

Headmaster - maintains a minimum discharge pressure during freeze

Liquid Inlet Valve - Normally Open, closes during harvest.

Receiver - stores liquid refrigerant for freeze and provides vapor for harvest

Suction Access Valve - provides a place to attach a refrigeration manifold for diagnostics and recovery.

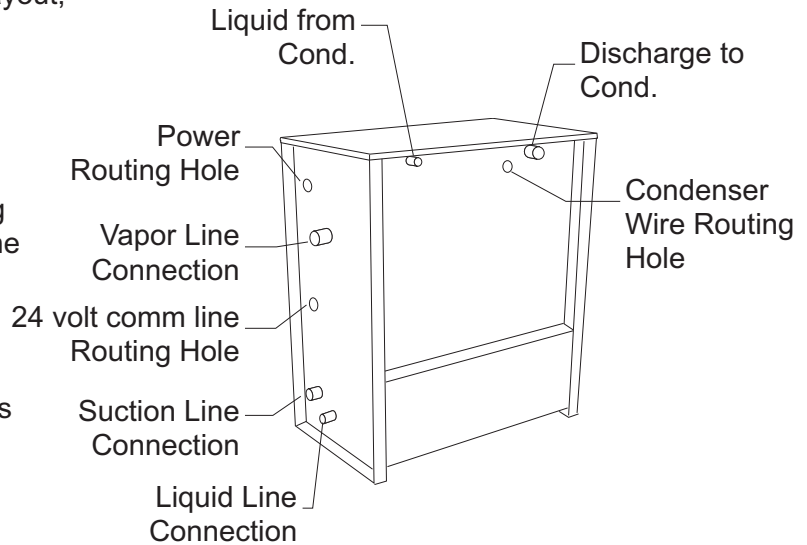

CP Unit Refrigeration Connection ID

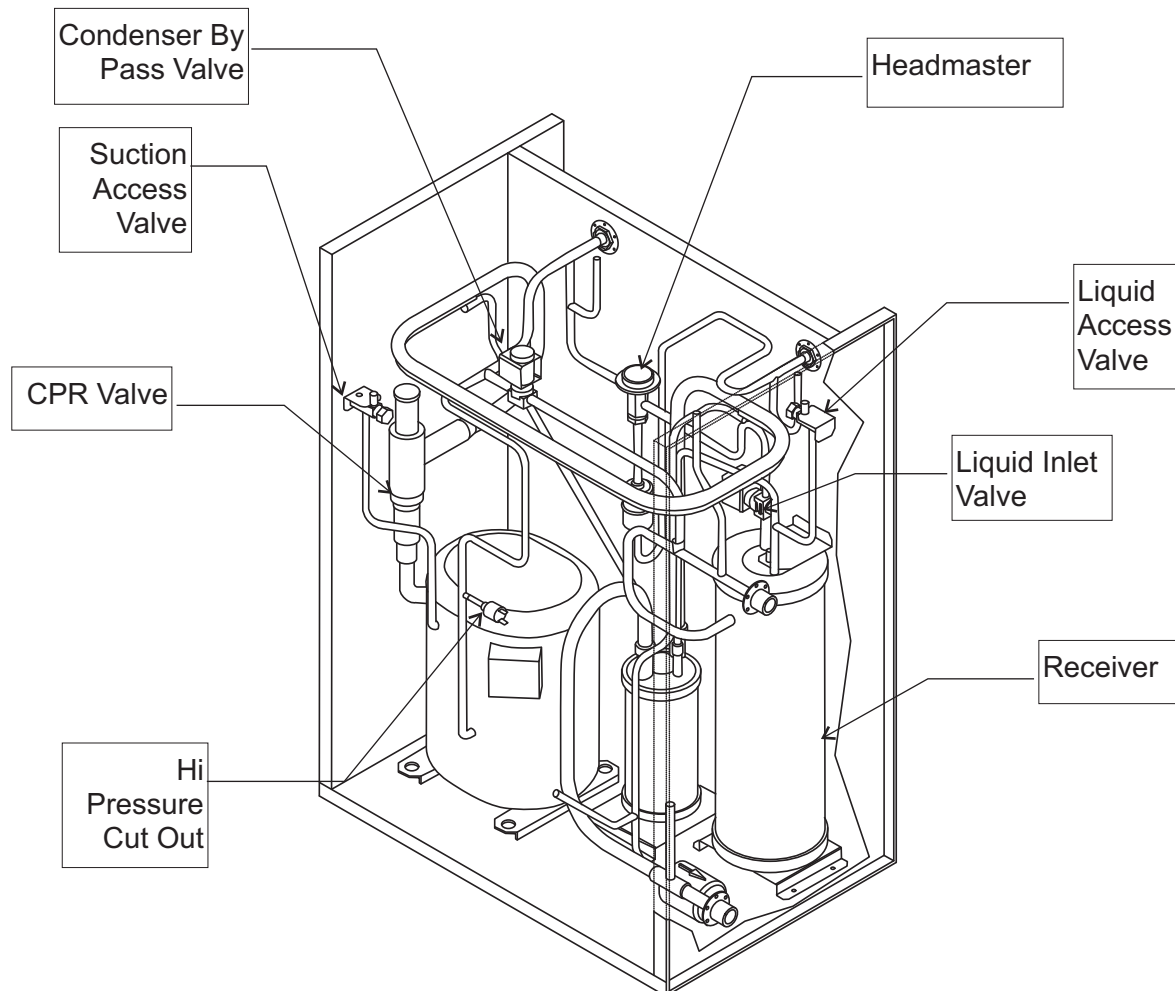

CP Component Location

Prodigy Eclipse™ 600, 800, 1000

Condensing Section Assembly

(C600/800/1410CP to ERC680 to ERC1086):

1. Remove cartons from compressor package and condenser.
2. Remove top from both units.
3. Remove front panel from CP unit.
4. Locate legs, secured to ERC unit.
5. Locate fasteners, inside junction box of ERC unit.
6. Assemble rear legs to ERC using fasteners from prior step.

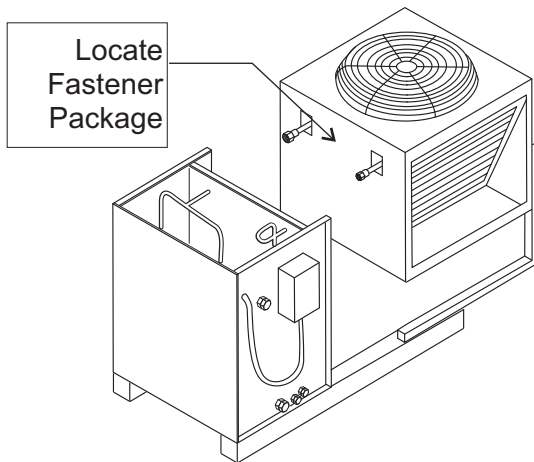

7. Locate wire package in CP unit. Remove short wires and two wire nuts.
8. Use wire & wire nuts from step 7 to connect to the wires inside the junction box of the condenser. Return junction box cover to its original position.
9. Place front of ERC on back flange of CP unit.
10. Secure CP unit to ERC.
11. Attach leg brace between ERC unit and CP unit.
12. Route wires from condenser through hole in back of CP unit to the CP unit control box.
13. Pull ERC female refrigerant connections forward to engage male connections on CP unit.
14. Rotate swivel nuts to tighten refrigerant connections. Use a back up wrench to hold female connection to prevent tearing of the diaphragms.
15. Connect wire to **T1** and **T2** of the contactor. Use the two wire nuts to connect the other end to the two black wires in the condenser junction box.
16. Return tops to their original positions.

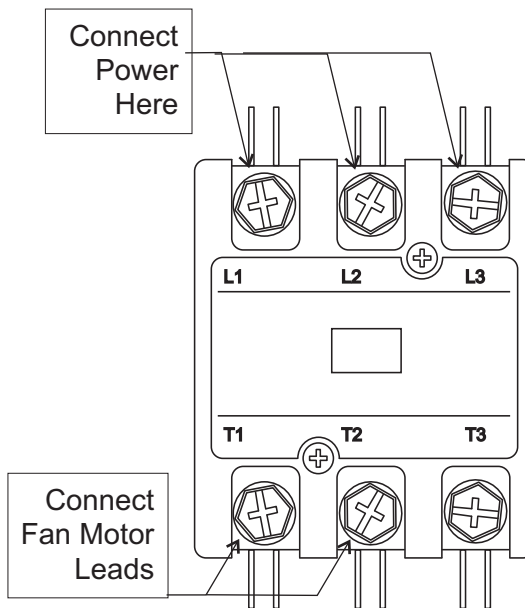

CP Unit Contactor, Three Phase Shown

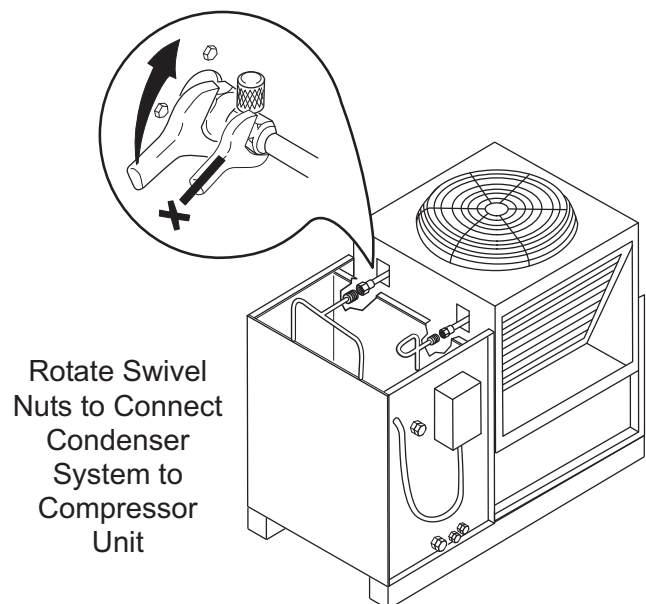

Condensing Section Assembly: ER2C6810

(C600/800/1410CP to ER2C6810):

1. Remove cartons from compressor package and two-circuit condenser.
2. Remove top from both units.
3. Remove front panel from CP unit.
4. If installing one CP unit, locate legs, secured to ERC unit. If installing two CPs, skip steps 5, 6, 7 and 9.
5. Locate fasteners inside junction box of ERC unit.

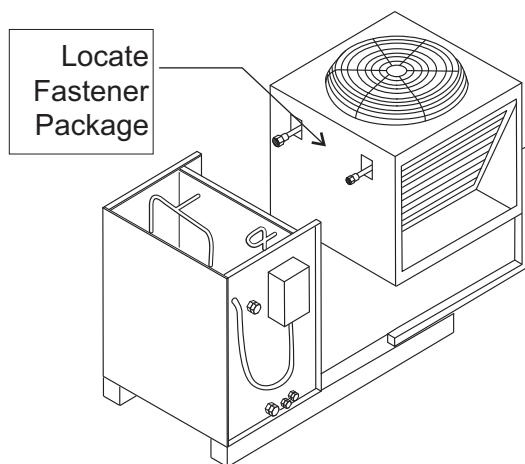

6. Assemble rear legs to ERC using fasteners from prior step.
7. Locate wire package in CP unit. Remove short wires and two wire nuts.
8. Use wire & wire nuts from step 7 to connect to the wires inside the junction box of the condenser. Return junction box cover to its original position.
9. Place front (with junction box) of ERC on back flange of CP unit.
10. Secure CP unit to ERC.
11. Attach leg brace between ERC unit and CP unit.
12. Pull ERC female refrigerant connections forward to engage male connections on CP unit.
13. Rotate swivel nuts to tighten refrigerant connections. Use a back up wrench to hold female connection to prevent tearing of the diaphragms.

14. Route wires from ERC junction box to CP junction box.

15. Attach condenser wires (from wire package) to **L1** and **L2** of the contactor.

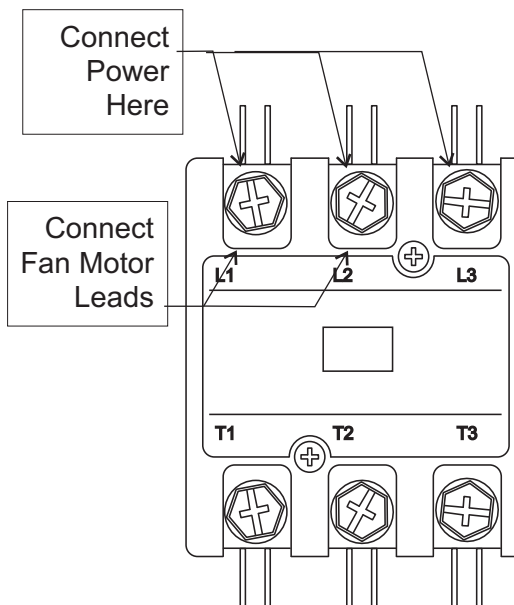

Two Circuit Condenser Installation, CP Unit Contactor, Three Phase Shown

The fan motor of the two circuit condenser will always be on.

If installing two CP units, connect the fan motor leads to only ONE of the two contactors.

16. Return tops to their original positions.

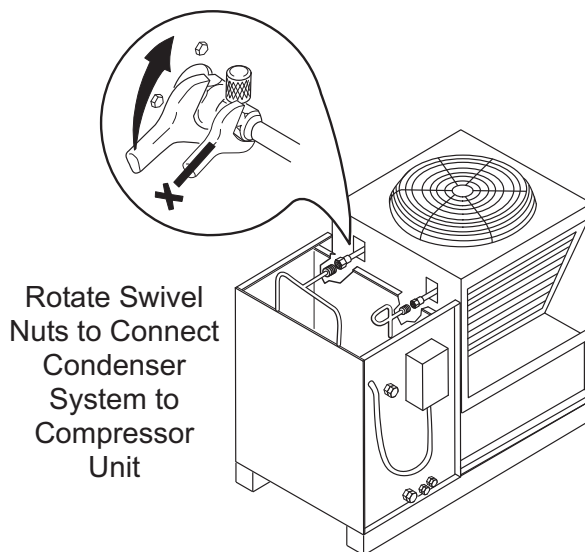

Rotate Swivel Nuts to Connect Condenser System to Compressor Unit

Prodigy Eclipse™ 600, 800, 1000

Condensing Section Assembly

Alternate Assembly:

The CP unit may be connected to an approved condenser coil in a central condenser rack. In those cases, the CP unit must be connected to the condenser coil using special kit RTE10.

Position the CP unit in its final spot. It must be within 6 feet of the condenser coil connections.

Route tubing from kit RTE10 from the CP unit to the condenser coil.

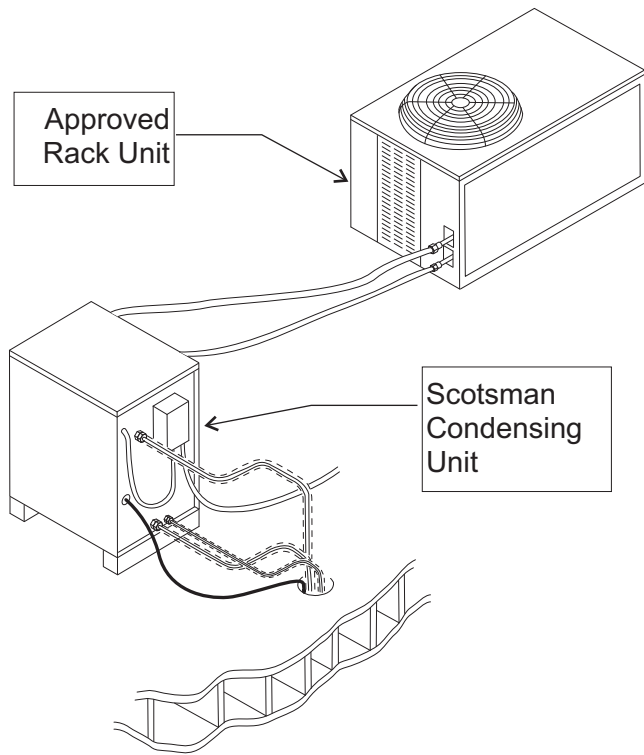

Connect tubing per the Coupling Instructions in this manual.

No wire connection is required between the CP unit at the condenser.

Note: Approved condensers must maintain power to their fan motor at all times.

All Assemblies:

Route interconnecting control wire through proper hole in side of CP unit and plug into the connection on the bottom of the control box.

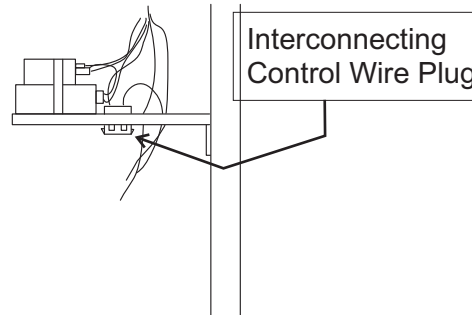

Control Wire Connection in CP Unit

Route power conduit (liquid tight) and wires to the hole in the side of the CP unit. Secure with the proper type of connector.

Note: The power supply wires must be the correct size and type per the National Electric Code. Locate the nameplate on the CP unit for the Voltage, Phase, Minimum Circuit Ampacity and Maximum Fuse Size. Either fuses or HACR type circuit breakers may be used.

Follow all Local, State and National Codes.

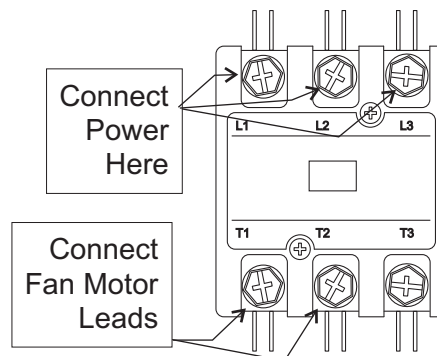

CP Unit Contactor, Three Phase Shown

Connect power wires to the contactor, L1 and L2 if single phase, L1, L2 and L3 if three phase. Note: If there is a "wild leg" in the three phase power supply place it on L3.

Connect electrical power to the CP unit.

Return front of CP unit to its original position.

Ice making section:

Located at the top panel:

- Refrigeration quick connects.
- Interconnecting control wire.
- Access port for water supply.
- Power cord.

The drain may be routed to the left or right, allowing the ice making section to be placed with its back tight against a wall.

Remove from carton.

Place adapter kit onto bin or dispenser top. If adapter does NOT have gasket tape install tape such as Scotsman part number 19-0503-04.

Attachment:

ABS (Automatic Beverage Dispenser) in drive up installations: Route refrigerant tubing and install drain and water supply tubing onto ice making section before placing unit on the dispenser.

Place EH222 onto adapter, do not secure at this time. Uncoil power cord and route to the power supply. Plug interconnecting control wire to the wire harness in the ice making section.

Do not secure unit to adapter at this time.

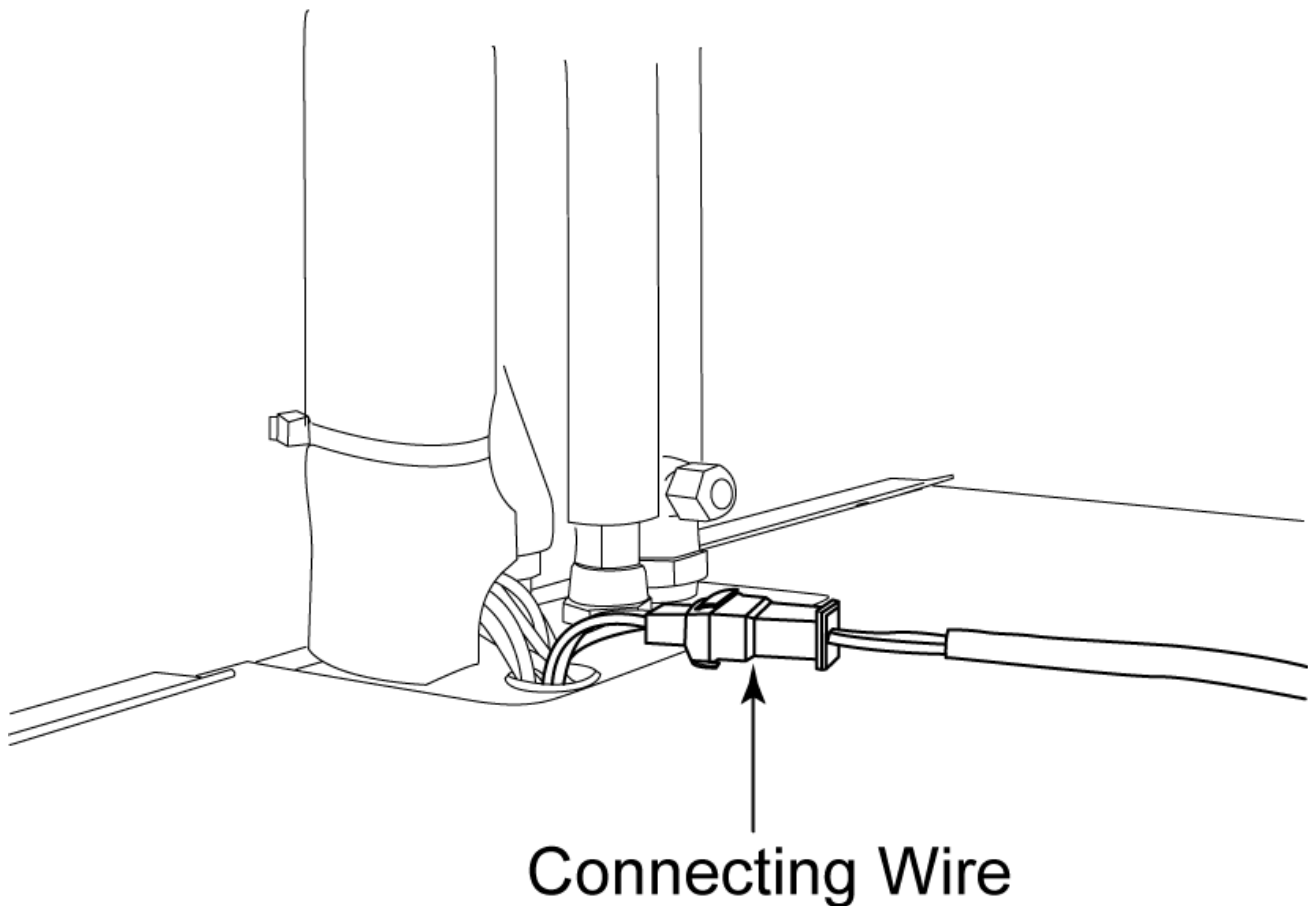

Prodigy Eclipse™ 600, 800, 1000

Water and Drain

The ice making section requires an adequate potable water supply and a gravity drain.

Determine how the drain will be connected to the ice making section.

- If access is available behind the unit, route the drain in from the back.
- If the unit is to be flush mounted to the back of the dispenser and tight against the wall, route the drain out either the left or right back corners

In some tight situations it will be necessary to assemble the ice making section to the dispenser or bin and install the water and drain connections before placing the system in its installed position. A loop of water supply tubing will allow movement of the system.

In other tight situations the unit should have its water and drain tubing connected and stubbed out before placing on the dispenser or bin.

The drain fitting is adaptable to drain connections to the left, right and back.

The unit is shipped ready to drain right. The drain fitting elbow with PVC adapter can be rotated to drain right, left or back.

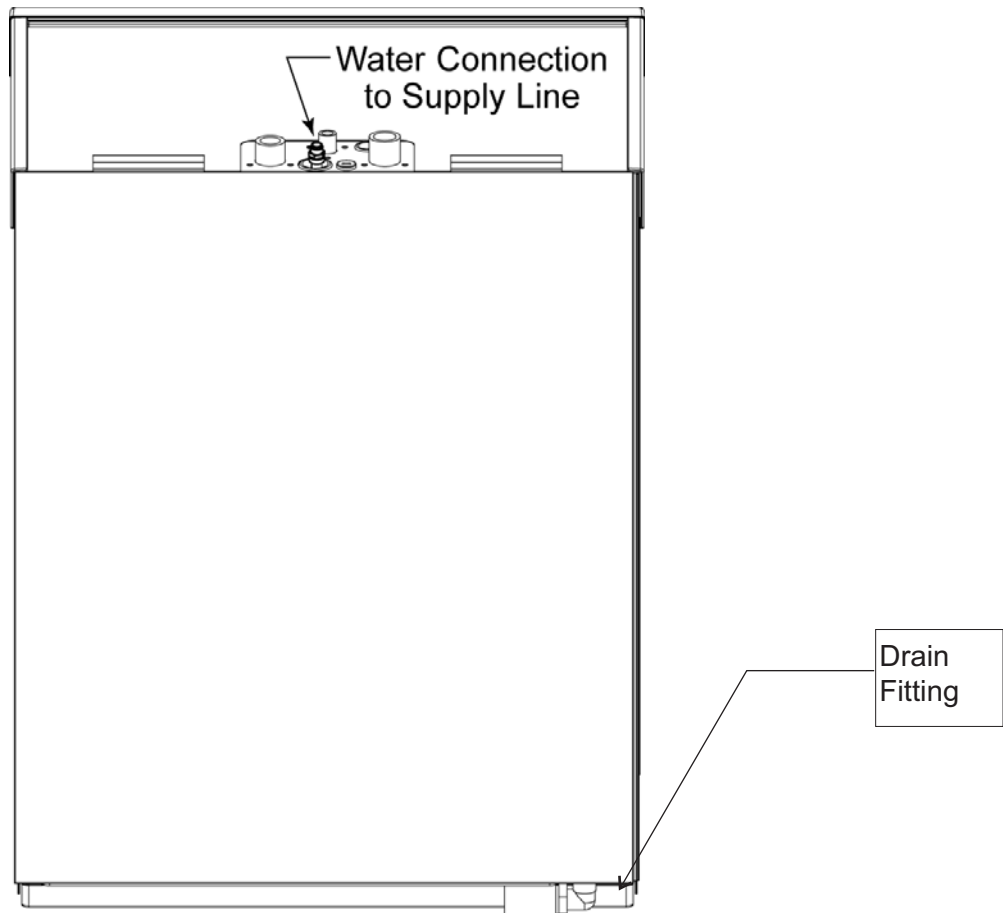

Back View of EH222

Water and Drain

Right Draining:

1. Connect $\frac{3}{4}$ " PVC to the female PVC fitting. If copper is required by code, remove the PVC connector and install a $\frac{3}{4}$ " FPT female copper fitting onto the $\frac{3}{4}$ " NPT male fitting. Do all soldering before connecting to the male fitting.
2. In tight locations do the next step after the unit is placed on the dispenser or bin.
3. Connect rigid drain tubing to the reservoir drain tube. Route the drain either out the back, under the unit (through the notch in the base) to the left side or to the right side. **A vent is built into the unit, so no external vent is required.**

Run the drain tubing to the building drain. Do not "Tee" into any other drain, including the bin or dispenser drain.

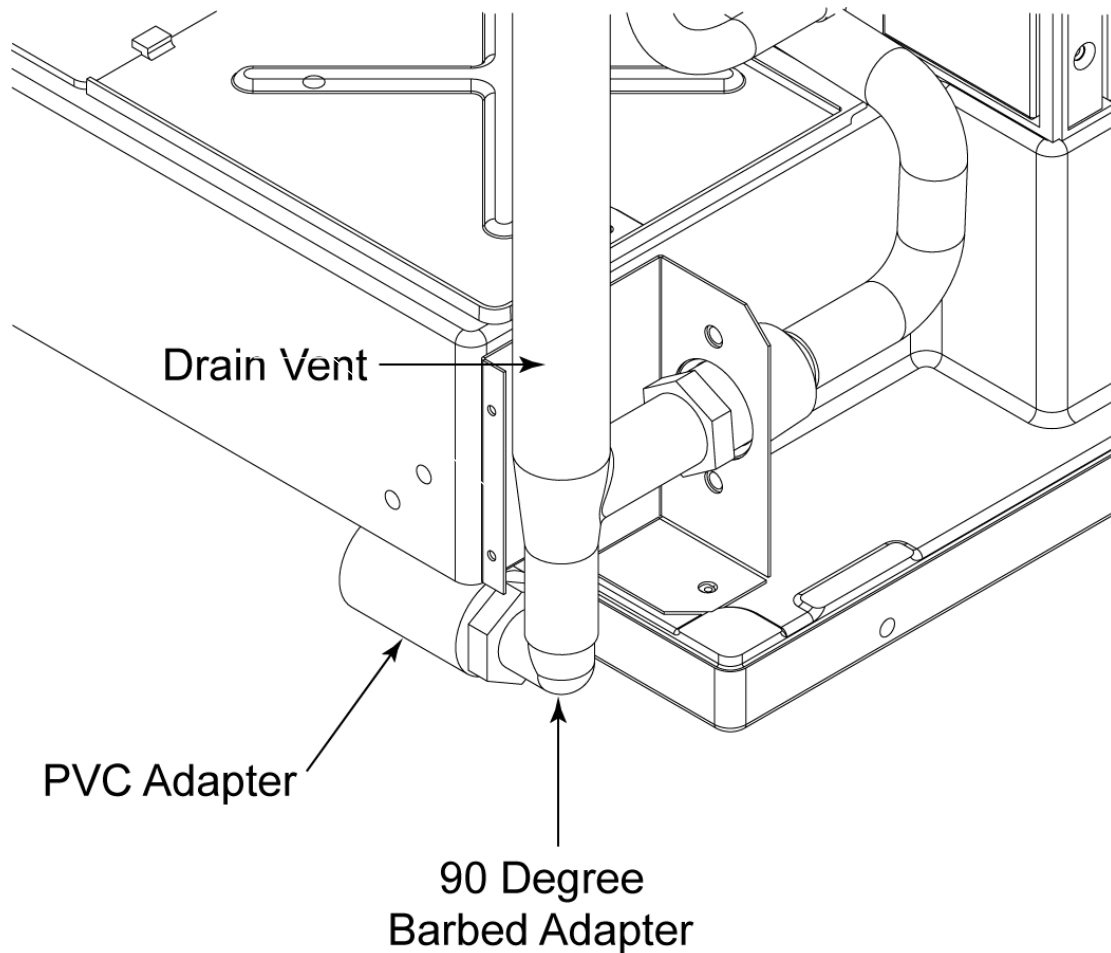

Prodigy Eclipse™ 600, 800, 1000

Water and Drain

Left Draining: Rotate elbow to the other direction. Connect 3/4" PVC to the PVC fitting.

Back Draining: Rotate elbow to face the back or connect PVC directly into the 3/4" FPT drain fitting.

No external drain vent is required, venting is internally provided for.

Note: External drain tubing must be supported to insure that it does not move and kink the internal rubber tube.

Water Supply: A 3/8" flare nut on tubing is located at the top panel, near the refrigeration tubing. Inside the hardware bag, inside the cabinet, a 3/8" inch double male flare adapter is supplied. Use the supplied adapter to make a 3/8" male flare fitting for the water inlet.

Connect a cold, potable water supply to the 3/8" water inlet fitting installed above. Use 3/8" OD copper or other comparable sized tubing for the water supply.

Note: This is an NSF listed ice machine and contains provisions for back-flow prevention in its design. No external back flow preventer is required.

Drain: Connect rigid drain tubing to the reservoir drain fitting on the left side of the cabinet. Route the drain either out the back, under the unit (through the notch in the base) to the left side or to the right side. A vent is built into the unit, so no external vent is required.

Run the drain tubing to the building drain. Do not "Tee" into any other drain, including the bin or dispenser drain.

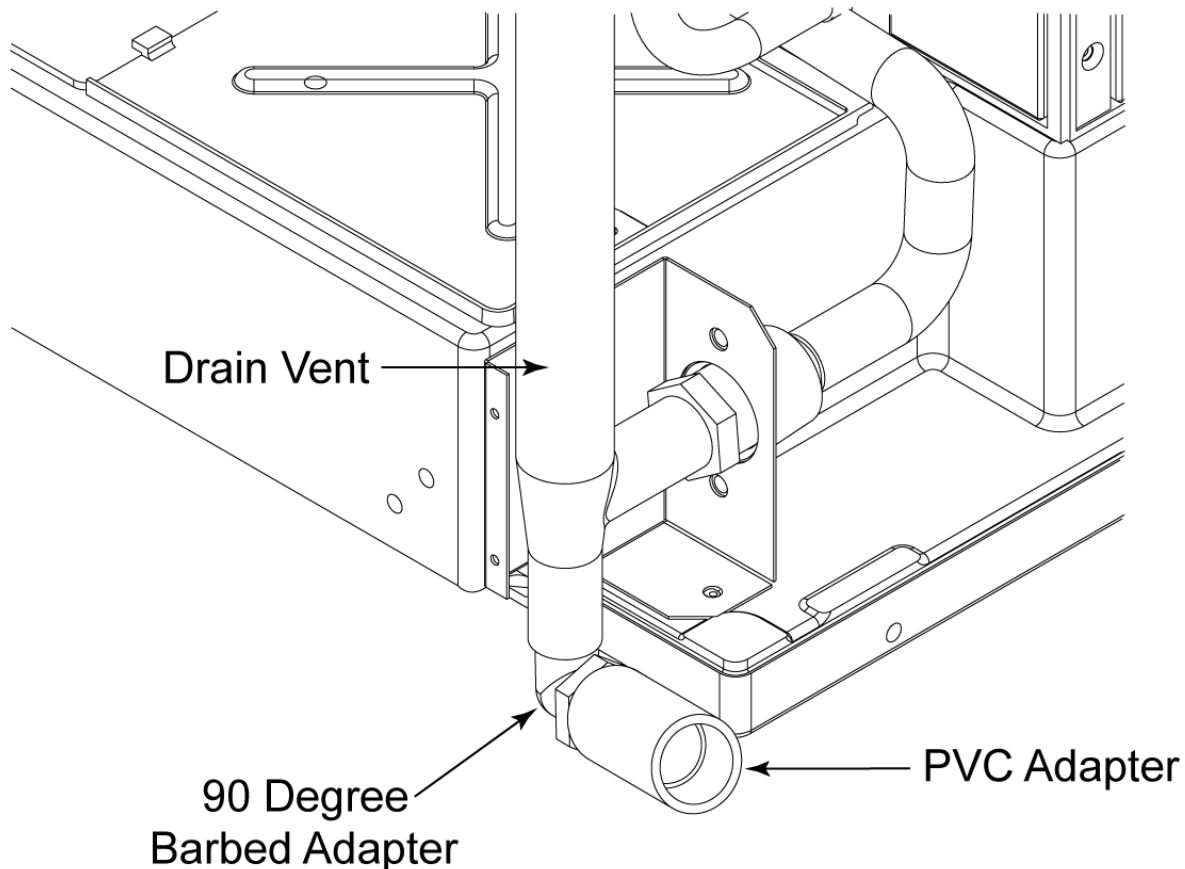

Back View, Drain Tubing Installed for Right Side Drain

Ice Making Section Set Up

Connect the suction line to the left fitting. Connect the liquid line to the middle fitting. Connect the vapor line to the right fitting.

See Coupling Connections on the next page for detailed instructions.

After couplings are connected, add cork-tape type insulation to exposed fittings to reduce condensation potential.

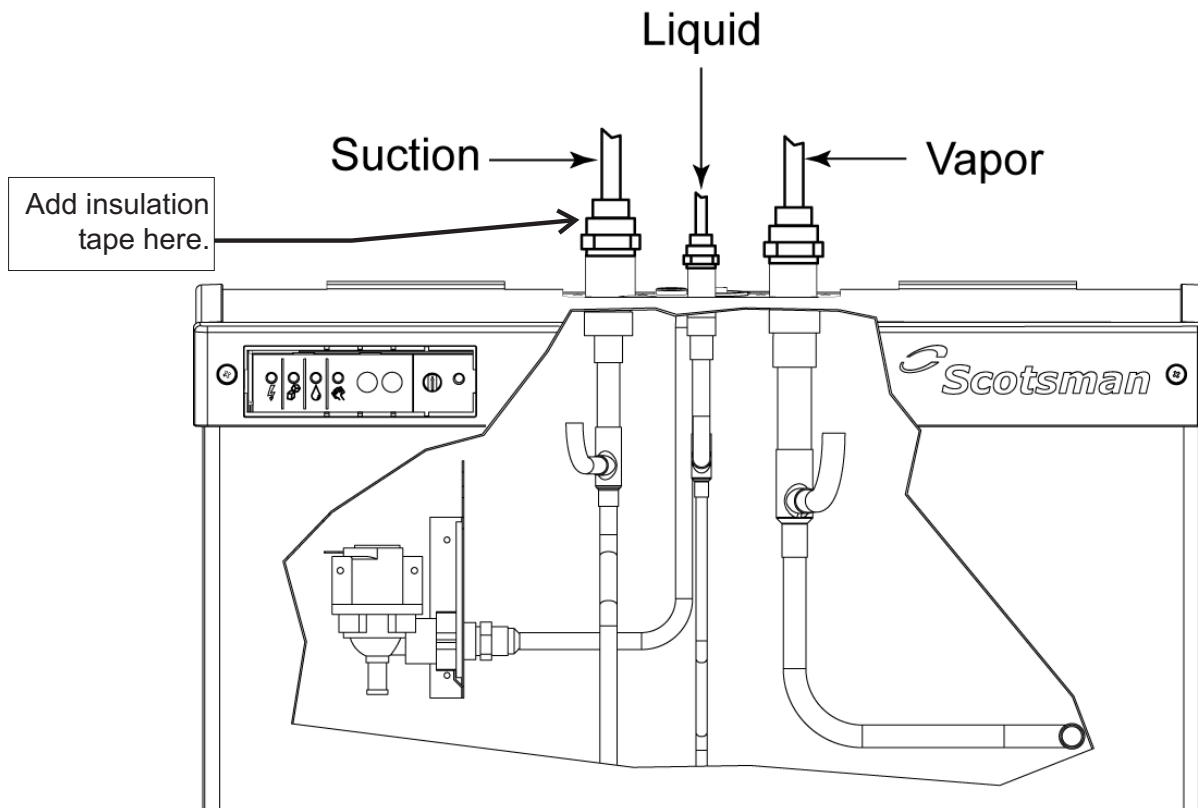

Refrigerant Lines, Shown Routed Out The Top

Prodigy Eclipse™ 600, 800, 1000

Coupling Connections:

The couplings on the ends of the pre-charged line sets are self-sealing when installed properly.

Follow these instructions carefully. These steps must be performed by an EPA Certified Type II or higher technician.

Initial Connections

1. Remove the protector caps and plugs. Wipe the seats and threaded surfaces with a clean cloth to remove any possible foreign matter.

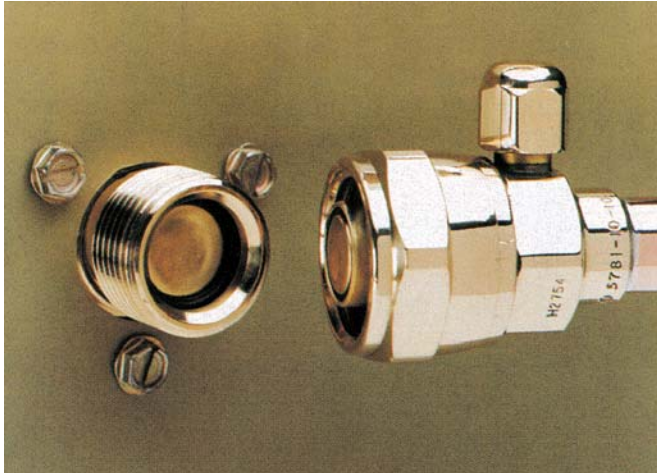

Clean and Lubricate Couplings

2. **Thoroughly and completely** lubricate the threads, o-rings, diaphragms and all internal coupling surfaces with polyolester refrigerant oil.

3. Position the fittings on the correct connections on the condenser and ice machine.

Final Connections:

4a. Begin to tighten the couplings together by hand. Be sure they are not cross-threaded. Continue to turn the swivel nuts by hand until it is certain that the threads are properly engaged.

4b. Using **two wrenches**, one to rotate the swivel nut and one to hold the tubing in place, tighten each coupling.

It is **CRITICAL** that **ONLY** the NUT on the pre-charged tube be turned, or the diaphragms will be torn by the piercing knives and become loose in the refrigeration system causing severe operational problems.

Note: As the coupling is tightened, the diaphragms in the quick connect couplings will begin to be pierced. As that happens, there will be increased resistance to tightening the swivel nut.

4c. Continue tightening the swivel nut until it bottoms out or a very definite increase in resistance is felt (no threads should be showing). Do NOT overtighten.

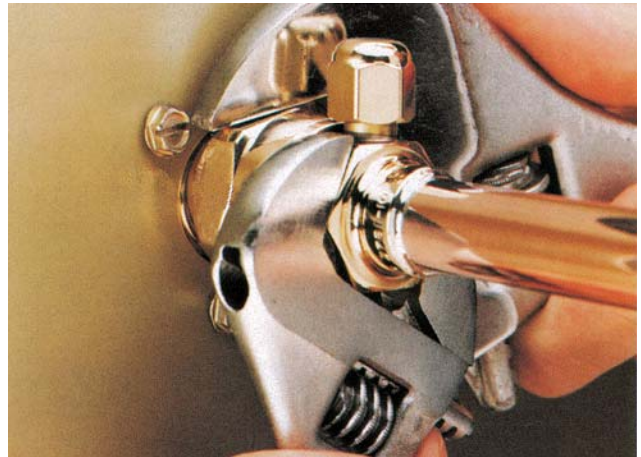

Tighten Swivel Nut

5. Use a marker or pen to mark a line on the coupling nut and unit panel. Then tighten the coupling nut an additional one-quarter turn. The line will show the amount that the nut turns.



Rotate Swivel Nut ¼ Turn More

6. After all connections have been made check the couplings for leaks.

7. Add cork tape to the swivel nut of the suction line to insulate it. **Be sure all exposed tubing of the suction line is insulated.**

Note: The system charge is contained in the receiver tank of the ice machine. Only "holding" charges are present in the "pre-charged" tubing or the condenser.

Condensing Unit Connections

Connect the suction line, the vapor line and the liquid line to the matching fittings on the CP unit.

See Coupling Connections on the prior page for detailed instructions.

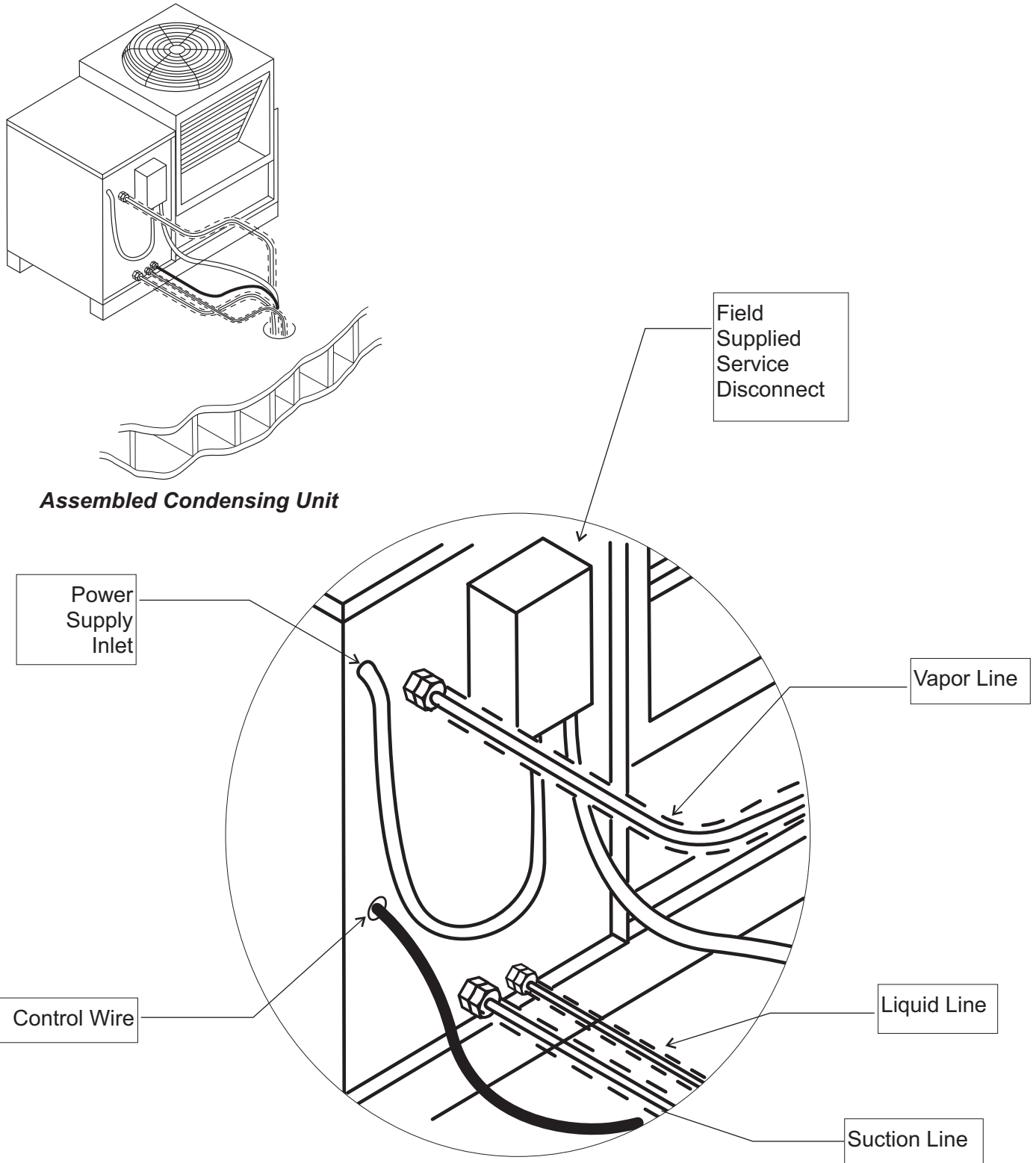

Prodigy Eclipse™ 600, 800, 1000

Final Placement

After the utilities and refrigeration connections have been made, secure the unit to the dispenser or bin top.

Secure ice making section to dispenser or bin adapter.

Use strap/clips to secure unit:

- When used with Cornelius ABS adapter, install clip on the side of the cabinet. Clip under edge of adapter and secure to ice making section using the screws provided in the hardware bag.

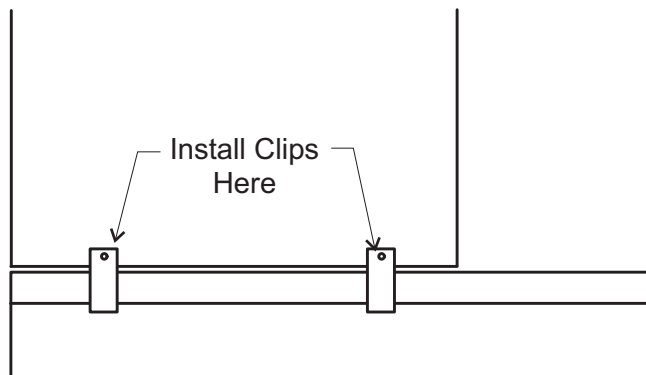

Left Side View of IMS on Dispenser

Note: If one side will be against a wall, do not use a clip on that side. One clip is sufficient to secure the unit.

- For use on bin adapter, use clip (as a strap) on back.

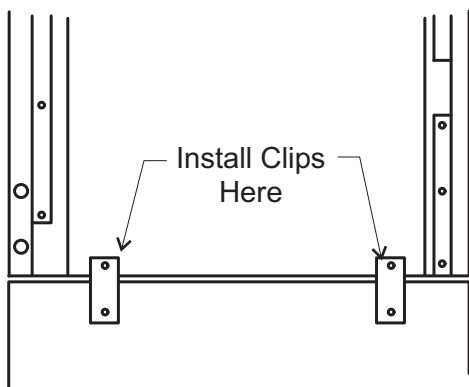

Back View, IMS on a Bin

If the ice maker & bin or dispenser is not yet in its final position gently move it there.

Note: The refrigerant lines above the machine must be able to move freely while the machine is being moved into position.

Final Check List Before Initial Start Up

1. Confirm that the ice making section is installed indoors in a controlled environment.
2. Confirm that all packing materials have been removed from all products.
3. Confirm that the ice making section is level.
4. Confirm that all the refrigerant connections have been made and checked for leaks.
5. Confirm that the proper power supply has been turned on to the condensing unit.
6. Confirm that cold, potable water has been supplied to the ice making section and checked for leaks.
7. Confirm that the water supply is adequate.
8. Confirm that there is adequate water pressure and that any water filters have been checked to confirm that the cartridges do not need changing.
9. Confirm that the proper size drain tubing has been installed and properly routed.
10. Confirm that the ice making section has been connected to the proper power supply.
11. Confirm that the interconnecting wire has been routed and connected between the ice making section and the compressor package.

Controller Operation

The controller has four indicator lights, a code display, four push buttons, and eleven component indicator lights.

Indicator Lights

- Power - on when there is power to the controller
- Status - on in ice making mode
- Water - on and blinking when there is no water
- De-scale & Sanitize - on when it is time to clean the machine

Code Display

- Displays status and diagnostic codes

Push Buttons

- On
- Off
- Manual Harvest
- Clean

Component indicator lights

- Fan - not used on this model
- Water Pump - on when the pump is
- Purge Valve - on when the purge valve is
- Water Solenoid - on when the inlet water solenoid valve is
- Hot Gas - on when the vapor inlet valve and harvest assist solenoid have power
- Compressor - on when the compressor contactor is energized
- Ready to Harvest - on when the ice thickness sensor has water touching it
- Sump Empty - on when there is no water touching the mid-length probe
- Sump Full - on when water is touching the shortest probe
- SW2 - on when the curtain is open
- SW1 - on when the curtain is open

Cycle Definitions:

Freeze: The refrigeration system is operating to remove heat from the evaporators. The compressor, fan motor, and water pump are on.

Harvest: The refrigeration system and water system are operating to harvest the ice and rinse the reservoir. The compressor is on for the full cycle, the pump is on until the purge valve closes. The inlet water valve opens and refills the reservoir. The vapor and condenser by-pass valves are open during the entire harvest cycle, as are the harvest assist solenoids.

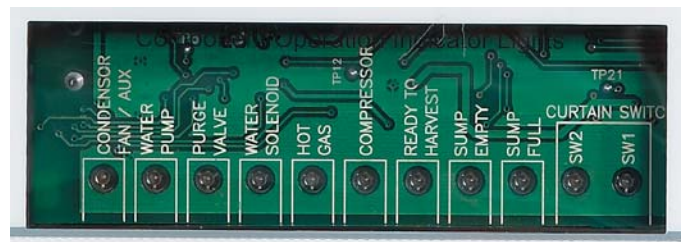

Prodigy Eclipse™ 600, 800, 1000

Initial Start Up

Pre Start

A soak-out period of four hours is optional for this system. If desired, powering the compressor unit for four hours prior to start up allows the crankcase heater to warm up the oil in the compressor.

Start Up

1. Connect power to the condensing unit and move its toggle switch to Run or On.
2. Open the water supply valve.
3. Remove front panel. Check machine for any packing or wires rubbing moving parts. Note location of control board in upper left corner of the machine's front.
4. Remove tape securing curtain to evaporator.
5. Switch on the electrical power to the EH222. Observe that some of the control's indicator lights glow and its display shows *0*.
6. Open the water supply valve.
7. Push and release the ON button. The code display will begin to blink *F*.

The purge valve opens, the water pump starts and the inlet water valve opens to add water to the reservoir. In a few seconds the purge valve closes and the water pump stops. Water will flow into the machine until the reservoir is full. The vapor valve and harvest assist device will activate, then the compressor and water pump will start.

Note: Because the condensing unit is external to the ice making section, no visible signs of operation will be noticeable until the water begins to cool and frost forms on the evaporator tubing.

8. Go to the condensing unit and confirm that the compressor and fan motor are operating. Warm air will be discharged from the condenser.

Observe the Ready for Harvest indicator light. It may blink early in the cycle, that is normal. The control will ignore that signal for the first 6 minutes of freeze.

During the Freeze cycle move the curtains and observe that the SW1 or SW2 light on the control board blinks On when the curtain moves away from the evaporator and Off when returned to its normal position.

Note: Moving the curtain during the Freeze cycle has no affect on control function, but will cause water to flow into the cube chute.

When enough ice has frozen, the Ready for Harvest indicator light will be on steady. After it's been on steady for a few seconds Harvest will begin.

The display shows an *H*. The vapor valve in the EH222 opens, and the harvest assist mechanism activates. In the CP the condenser bypass valve opens and the receiver inlet valve closes. In the EH222, the purge valve opens to drain some water, when it does the inlet water valve opens to refill the reservoir. After a few seconds the purge valve closes but the inlet water valve continues to fill the reservoir. Harvest continues until the ice is released as a unit and forces the curtain to open. When the curtain opens it signals the controller that harvest is complete, and it returns the unit to a freeze cycle.

9. Check the ice harvested for proper bridge thickness. The ice bridge is **factory set** at 1/8 inch. If needed, adjust bridge thickness. Do NOT make it too thin.
10. Return the front panel to its normal position and secure it to the machine.
11. Instruct the user in the operation of the machine and its maintenance requirements.
12. Fill out and mail the warranty registration form.

Ice Thickness and Water Purge Adjustment

Bridge Thickness - For the Service Tech Only

1. Push and hold Off till the machine stops.
2. Remove evaporator cover.
3. Remove curtain.
4. Use a hex wrench and rotate the bridge thickness adjustment screw in 1/16 turn increments CW to increase bridge thickness.

Rotate CCW to decrease bridge thickness.

Caution: Do not make the bridge too thin or the machine will not harvest properly. Bridge thickness adjustments are not covered by warranty.

5. Return curtain and evaporator cover to their normal positions.

6. Push and release the On button. Check next harvest of ice. Repeat steps 1-6 if needed.

Water Purge Setting

The water purge is factory set to the automatic position, suitable for most water conditions. The setting can be changed to one of 5 manual settings or left on automatic.

Purge setting

Setting	Water Type
1	Minimum - RO water or equivalent
2	Moderate - Low TDS, non RO
3	Standard - Use with typical water
4	Heavy - High TDS
5	Maximum - Very high TDS
A	Automatic - Factory setting

Any with conductivity not less than 10 microSiemens/cm

To set:

1. Switch the machine OFF by holding the Off button in until a number or the letter *A* shows on the display.
2. Press and release the On button repeatedly until the number on the display corresponds to the desired setting.
3. Press and release the Off switch again to return to the normal control state.

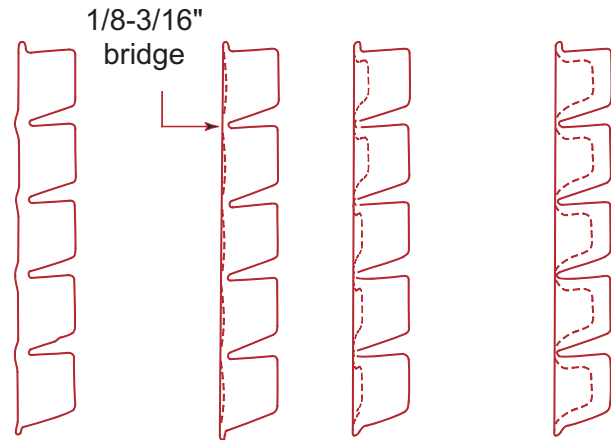

Ice Bridge Thickness Measurement

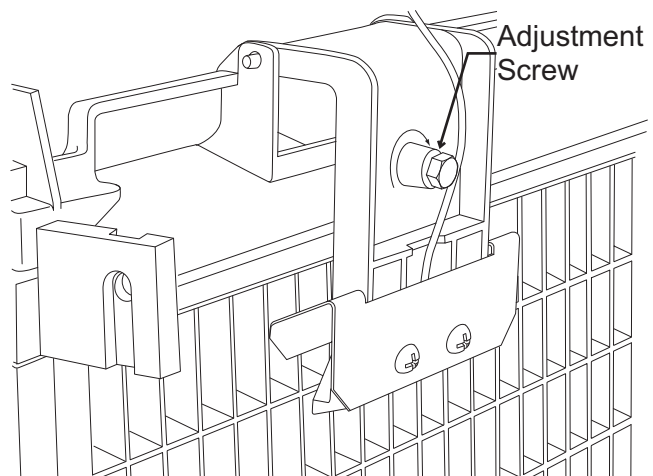

Bridge Thickness Adjustment Mechanism

Prodigy Eclipse™ 600, 800, 1000

Controller Information

Machine Indicator Lights

- Power
- Status
- Water
- Clean

Code Display

Main codes - automatically displayed

<i>F</i>	Freeze Cycle
<i>F</i> flashes	Freeze Cycle is Pending
<i>H</i>	Harvest Cycle
<i>H</i> flashes	Manual Harvest
<i>b</i>	Bin is Full
<i>C</i>	Clean Cycle
<i>L</i>	Board Locked
<i>d</i>	Test Mode
<i>0</i>	Off
<i>E</i>	Self Test Failed
<i>1</i> flashes	Max Freeze - Retrying
<i>1</i>	Max Freeze Time Shut Down
<i>2</i> flashes	Max Harvest - Retrying
<i>2</i>	Max Harvest Time Shut Down
<i>3</i>	Slow Water Fill
<i>4</i>	High Discharge Temp
<i>5</i>	Sump Temp Sensor Failure
<i>7</i>	Discharge Temp Sensor Failure
<i>8</i> flashes	Short Freeze - Retrying
<i>8</i>	Short Freeze - Thin ice

Setting Codes - requires push button sequence for access

Water Purge Settings

R, 1, 2, 3, 4, 5

De-scale Interval Settings

5, 5, 3, 3



Use and Operation

Once started, the ice machine will automatically make ice until the bin or dispenser is full of ice. When ice level drops, the ice machine will resume making ice.

Caution: Do not place anything on top of the ice machine, including the ice scoop. Debris and moisture from objects on top of the machine can work their way into the cabinet and cause serious damage. Damage caused by foreign material is not covered by warranty.

There are four indicator lights at the front of the machine that provide information on the condition of the machine.

Indicator Lights:

- Power
- Status
- Water

De-scale & Sanitize

Indicator Lights & Their Meanings				
	Power	Status	Water	De-Scale & Sanitize
Steady Green	Normal	Normal – bin full or making ice	-	-
Blinking Green	Self Test Failure	Switching on or off	-	-
Blinking Red	-	Diagnostic shutdown or, if making ice, temperature sensor failure	Lack of water	-
Yellow	-	-	-	Time to de-scale and sanitize
Blinking Yellow	-	-	-	In Cleaning mode
Light off	No power	Switched off	Normal	Normal
All Blinking	Unit remotely locked out – check with leasing company			

If the Water light is on, the machine has sensed a lack of water. Check the water supply to the machine. The water could have been shut off or the water filter cartridges might need to be changed.

If the De-Scale light is on, the machine has determined that it needs to be cleaned. Contact an authorized Scotsman service agent and have the machine cleaned, de-scaled and sanitized.

Note: A Component Indicator Light switches ON to indicate that the component is operating.

Note: There are two Curtain Switch lights, SW1 and SW2. These single plate models have one curtain switch light on all the time, as a curtain switch light is ON when a curtain is either open or not present.

Prodigy Eclipse™ 600, 800, 1000

Control Switches

The EH222 provides front access to two switches – On and Off. To switch the machine OFF, push and release the Off button. The machine will shut off at the end of the next cycle. To shut the machine off immediately, push and hold the Off button for 3 seconds.

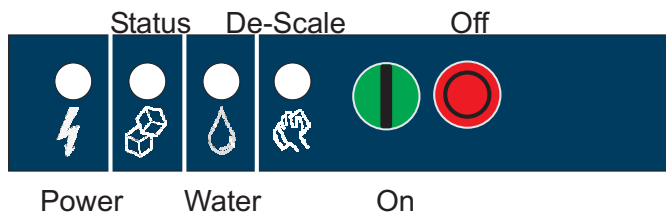

To switch the machine ON, push and release the On button. The machine will go through a start up process and then resume ice making.

The EH222 includes as standard, the Vari-Smart™ adjustable ice level control system.

Control Options

An optional, field installed control that can be added to this machine is the Smart-Board™ advanced control board and data logger. See the next page for more information.

Adjustable ice level control

There is an adjustment post and an additional indicator light to the right of the four indicator lights mentioned above. The ultrasonic ice level control allows the user to control the point that the ice machine will stop making ice before the bin or dispenser is full. Reasons for this include:

- Seasonal changes in ice used
- Planning to sanitize the bin
- Certain dispenser applications where maximum ice level is not desired

Use of control

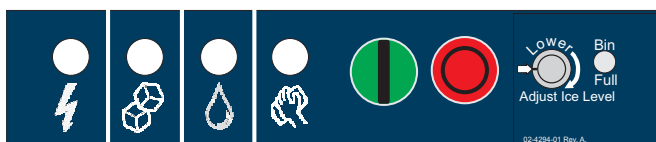

VariSmart Control Area

There are several positions the ice level can be set to, including Off (knob and label indicators lined up), where it fills the bin until the standard bin control shuts the machine off.



Normal Setting for ABS Dispensers



Setting for Maximum Ice Level

Rotate the adjustment post to the desired ice level. The machine will fill up to that level and when it shuts off the indicator light next to the adjustment post will be On.

Suggested Adjustment Knob Position for use with the ABS: first CW position - as shown above.

Note: Ice will build up in the bin or dispenser at an angle, the distance set will be from the sensor to the top of the ice. The sensor position is shown in the cabinet layout diagrams.

The actual distance between the highest point of the ice may be closer or further away than the distance set, depending upon the angle of the ice.

Options

Advanced Feature Board, kit #KSB

When this option is present there is an additional display panel in the area below the main control board. It is not visible when the front panel is on. The Smart-Board's features include:

- Seven day programmable ice level setting when used with the optional Ultrasonic ice level control
- Recording of machine operation, including cycle time.
- Calculation of average cycle time
- Recall of malfunctions with the time they occurred.

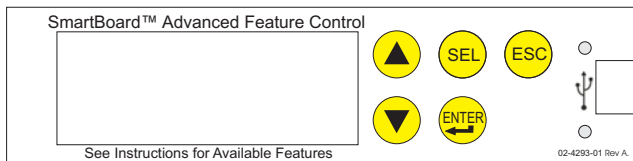

Ice

The cuber drops ice in large sections. That ice will break up into random parts as it falls into the bin, but some large sections may remain on top of the ice in the bin. When removing ice, tap the groups of ice with an ice scoop to separate them into smaller units. In a dispenser, this ice will break up into mostly individual cubes as the dispense mechanism moves the ice.

The ice in the bin will slope down from the right to the left. This is normal.

Noise

The ice machine will make little noise when it is in ice making mode. The compressor and fan motor are remote from the ice making head. The water pump in the ice making head will produce some sound. It is also normal to hear some cracking just before the harvest cycle begins. In addition, during the harvest cycle the harvest assist solenoid will click twice as it pushes the ice out and returns to its normal position. The ice harvests as a unit or slab, which makes some noise when it impacts the bin or dispenser. These noises are all normal for this machine.

Prodigy Eclipse™ 600, 800, 1000

System Operation:

This section is intended for the technician. Understanding it is not necessary for the normal operation and maintenance of this ice making system.

Major Components:

Ice making section sub-system:

- Controller,
- Water Level Sensor,
- Transformer,
- Evaporators,
- Expansion Valve
- Vapor Inlet Valve
- Water Pump,
- Inlet Water Valve
- Purge Valve.
- Harvest Assist Solenoid

Compressor Package sub-system:

- Compressor,
- Contactor,
- Condenser Bypass Valve,
- Liquid Inlet Valve,
- Receiver,
- Accumulator,
- CPR Valve,
- Headmaster.

Condenser sub-system:

- Coils
- Fan Motor

Freeze:

In the air cooled condensing unit sub-system (compressor package and condenser) the compressor is on, the condenser by-pass valve is closed, the fan motor is rotating the fan blade.

Harvest:

During harvest the compressor and fan motor continue to operate. The vapor inlet, condenser bypass, receiver inlet solenoid (normally open) and harvest assist solenoids are energized.

Ice releases and falls into the bin or dispenser.

Refrigeration Details:

The compressor provides the force that circulates refrigerant in the refrigeration system. During freeze, when the vapor inlet and condenser by pass valves are closed, discharge gas flows from the compressor into the condenser, where its heat is discharged into the air stream. Liquid refrigerant flows out of the condenser and through the normally open liquid line outlet valve on its way to the receiver inlet. Under low ambient/low pressure conditions, the headmaster valve closes the liquid outlet of the condenser and opens a bypass route to direct refrigerant gas to the receiver inlet until discharge pressure builds back up to the headmaster's set point.

From the receiver liquid outlet, liquid refrigerant flows into the liquid line and into the ice making section. At the ice making section, the refrigerant flows into the expansion valve where a pressure change takes place. The liquid refrigerant moves from the expansion valves into a low-pressure area (the evaporators) where it can rapidly evaporate and absorb heat. Heat is absorbed from the copper evaporator tubing, attached copper and the water flowing over the evaporator. The low-pressure refrigerant gas then flows into the suction line, which carries it back to the condensing unit, where it enters the accumulator. In the accumulator most of any liquid carried with the suction gas is separated and only vapor flows out of the accumulator through the CPR valve and to the compressor where the cycle continues.

During harvest discharge gas flows through the open condenser by pass valve into the vapor line. Power is also applied to the coil of the liquid inlet valve, closing it. At the same time, in the ice making section, the vapor inlet valve opens. Discharge gas, combined with some vapor from the receiver's outlet, then flows through the vapor line to the evaporator inlet. The gas-vapor combination, when entering the

relatively cold evaporator, condenses, transferring latent heat to the evaporator, which warms it. Ice releases and falls into the bin. The low-pressure refrigerant then flows out of the evaporator and into the suction line. The suction line brings the refrigerant, now consisting of a vapor-liquid combination, to the accumulator. From the accumulator the vapor-liquid combination (now more vapor than liquid) goes to the Crankcase Pressure Regulator valve which limits the amount of dome pressure in the compressor, where the cycle continues.

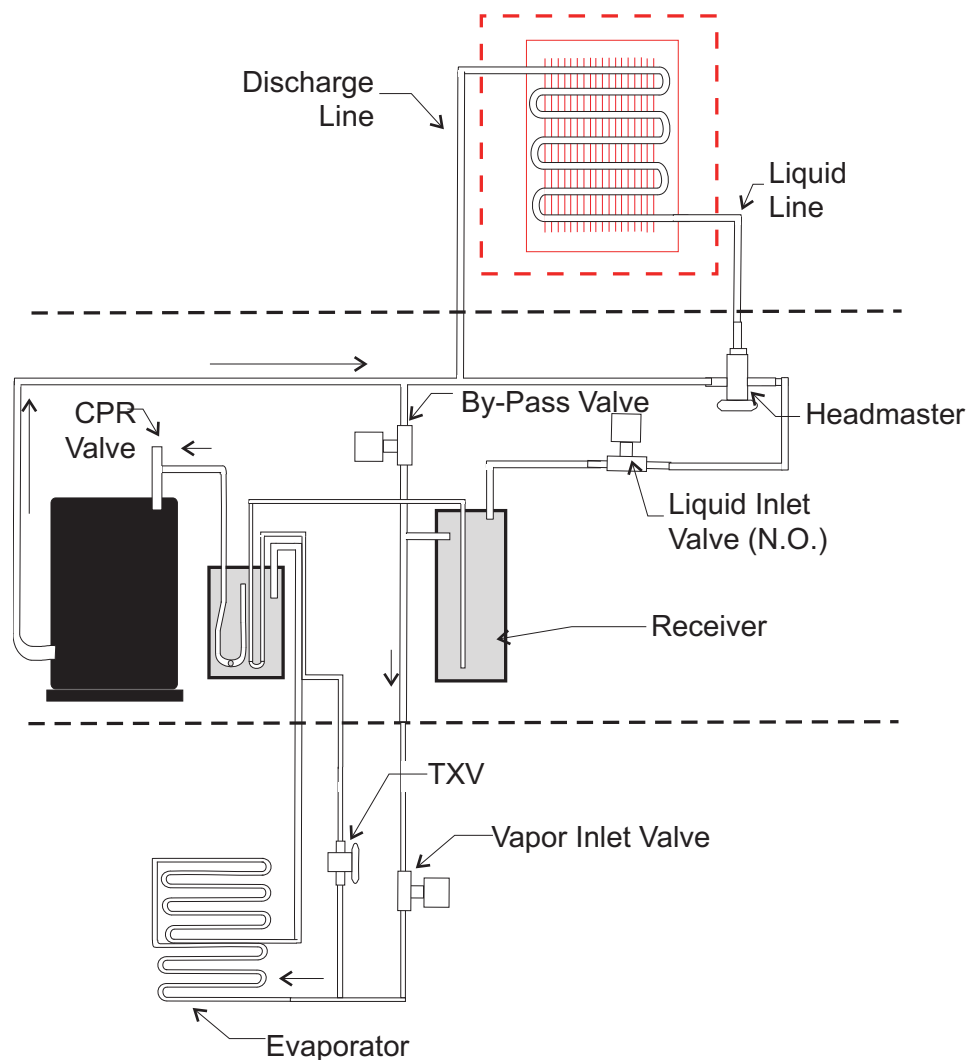

Prodigy Eclipse™ 600, 800, 1000

Technicians Only: Freeze Cycle Sequence of Operation

This sequence begins with a restart after the unit has shut off with the bin full. Ice has been consumed, causing the ice sensors to become un-blocked.

1. The controller (four minutes has to have passed since the machine shut off on bin full for the machine to restart)
2. The purge valve is opened and the pump started.
3. After the purge valve closes the inlet water valve opens and fills the reservoir.

Note: If the water reservoir does not fill within the time period expected the controller will shut off and switch on the water indicator light. It will re-try to fill the reservoir in 20 minutes. If successful the freeze cycle will continue.

4. The compressor and fan motor start and the freezing process begins.

Note: The controller is connected to two external relays in the EH222, one for the CP's compressor contactor and the other for the CP's solenoid valves. A separate 24 volt transformer is in the CP supplying power to the contacts of these two line voltage relays through the interconnecting wire.

5. The controller will shut the water pump off for a few seconds when the reservoir's water temperature reaches a pre-set point.
6. The freeze cycle continues until water makes continuous contact with the ice thickness sensor. That signals the controller to terminate the freeze cycle and begin the harvest cycle. The Ready to Harvest light will be ON.

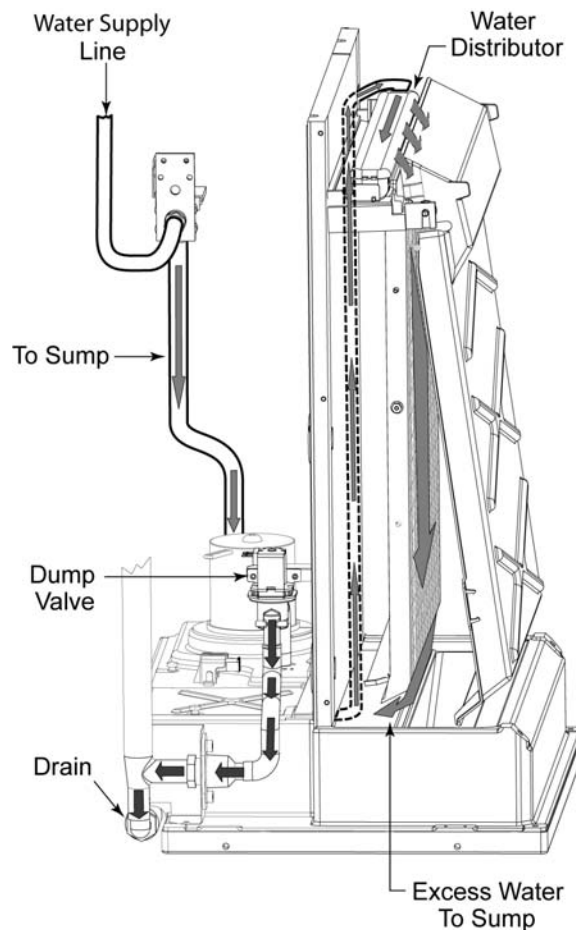

Water Schematic

Technicians Only: Harvest Cycle Sequence of Operation

When harvest begins, the controller connects power to the external relay for the CP's solenoids.

It also connects power to the vapor inlet solenoid valve in the cabinet of the EH222.

The vapor inlet solenoid valve and the condenser bypass valve open. The receiver inlet solenoid valve closes. Vapor flows from the condensing unit to the EH222 evaporator inlet.

The water pump and purge valve will be on for a period of time during the first part of harvest to purge the water reservoir of a portion of the water. The inlet water solenoid valve opens to fill the reservoir when the water level sensor indicates an empty sump. It continues to fill when the pump and purge valve have shut off and will stop filling when the water level sensor senses a full sump.

Harvest will continue until both curtains have opened. The curtain switch, attached to the edge of each curtain, will sense the curtain opening.

If the curtains both close, harvest will terminate and the freeze cycle will resume.

If one or both of the curtains remains open for 30 seconds, the machine will shut down.

Prodigy Eclipse™ 600, 800, 1000

Control Safeties

Max freeze time – 45 minutes

When exceeded, the controller will attempt another freeze cycle. If the condition is exceeded again the next cycle, the control will again attempt another freeze cycle. If the freeze cycle exceeds the maximum time in 3 consecutive cycles, the controller will shut the machine off and it must be manually reset.

Min freeze time – 6 minutes

If the controller switches the machine into harvest within 20 seconds of the minimum freeze time, the controller will harvest for a preset time and does not stop if the curtain switch opens. If this occurs again in the next three cycles, the machine will shut down and must be manually reset.

Max harvest time – 3.5 minutes

If the harvest cycle has continued for 3.5 minutes without the curtain opening, the controller will shut the machine off for 50 minutes and then restart. If there is another the machine will shut the machine off for another 50 minutes and then restart. If it fails a third consecutive time the controller will shut the machine down and must be manually reset.

- Time between resets – 50 minutes
- Number of automatic resets – 2
- Max water fill time – 5 minutes. Machine will attempt a restart every 20 minutes.
- Max discharge temp – 250 degrees F.
- Time interval between cleanings – 6 months power on time - adjustable in one month increments, can be set at 6, 5, 4 or 3 months of power up time.
- Manual harvest time – 3 minutes
- Pump down interval – remote only. 12 hours. Pump down is 30 seconds of compressor only on time.
- Minimum compressor off time – 4 minutes
- Continuous Run Time Maximum Cycles - 25

Restarts

Power Interruption

The controller will automatically restart the ice machine after adequate voltage has been restored.

- *H* blinks on code display
- Status indicator light blinks
- Reservoir is drained and refilled
- Default harvest is initiated. The curtain switch does not have to open to terminate harvest, harvest will continue until the default harvest time expires. Default harvest time is 3 minutes. The machine will then return to a normal freeze cycle.

Water Interruption

The controller will attempt to fill the reservoir every twenty minutes until it is successful.

Controller Operation

Control Button Use (from standby - status light off)

Set purge level, 1-5 (1 is minimum, 5 is maximum) or Automatic:

- Hold off button in for 3 seconds. Release.
- Press and release the On button to cycle through and select one of the five purge settings or to use the Automatic setting.

Recall diagnostic code:

- Hold off button in for 3 seconds. Release.
- Press and release the Harvest button to cycle through each of the last 10 error codes from most recent to oldest.

Clear diagnostic code:

- Hold Clean and Harvest buttons in for 3 seconds to clear all prior codes.

Reset control:

- Depress and release Off, then depress and release On

Start Test Mode:

- Hold Off button in for 3 seconds. Release.
- Hold Clean button in for 3 seconds. Release.

Lock / Unlock control:

- Hold On button in for 3 seconds, keep holding then press and release Off twice.

Empty reservoir:

- Hold Clean button in for 3 seconds. Release. Pump and purge valve will be ON for 30 seconds. Repeat as needed.

Test Mode:

- Depress Off for 3 seconds, release. Then depress Clean for 3 seconds.
- The sump will fill the first 30 seconds of the test. If the sump is full it will overflow into the bin. At 30 seconds the Water Inlet Valve will shut off and the Water Pump will turn on. You will be able to see and hear the water running over the plates. After 10 seconds the Purge and Vapor Inlet Valves will turn on. Water will be purging from the machine. After 10 more seconds the compressor will start. 5 seconds later the VIV will close. The compressor will run for a total of 20 seconds. After which everything will turn off for 5 seconds. After that time the VIV will open and you'll be able to hear the hissing as the pressure is equalized. 10 seconds later the fan will turn on (if air cooled). After 10 seconds all will be off and the output test will be complete.

Change De-Scale Notification Interval

Like the others, this feature is accessible only from standby (Status Light Off).

- Press and hold harvest button for 3 seconds.
- This will allow control to enter Time to Clean Adjustment State.
- Display current time to clean months on 7 segment display.
- Pressing clean button repeatedly will cycle through one of 4 possible settings:

6 months (4380 hours) (default)

5 months (3650 hrs)

4 months (2920 hrs)

3 months (2190 hrs)

Prodigy Eclipse™ 600, 800, 1000

Cleaning, Sanitation and Maintenance

This ice system requires three types of maintenance:

- Remove the build up of mineral scale from the ice machine's water system and sensors.
- Sanitize the ice machine's water system and the ice storage bin or dispenser.
- Clean the air cooled condenser.

It is the User's responsibility to keep the ice machine and ice storage bin in a sanitary condition. Without human intervention, sanitation will not be maintained. Ice machines also require occasional cleaning of their water systems with a specifically designed chemical. This chemical dissolves mineral build up that forms during the ice making process.

Sanitize the ice storage bin as frequently as local health codes require, and every time the ice machine is cleaned and sanitized.

The ice machine's water system should be cleaned and sanitized a minimum of twice per year.

- 1 Remove the front panel.
- 2 Remove the evaporator cover.
- 3 If the machine is operating, push and release the Harvest button. When the machine completes the Harvest cycle it will stop. If the bin is full (b shows in display) push and release the Off button.
- 4 Remove all ice from the storage bin or dispenser.
- 5 Push and release the Clean button. The yellow Clean light will blink and the display will show c. The machine will drain the reservoir and refill it. Go onto the next step when the reservoir has filled.
- 6 Pour 12 ounces of Scotsman Clear 1 nickel safe scale remover into the reservoir.

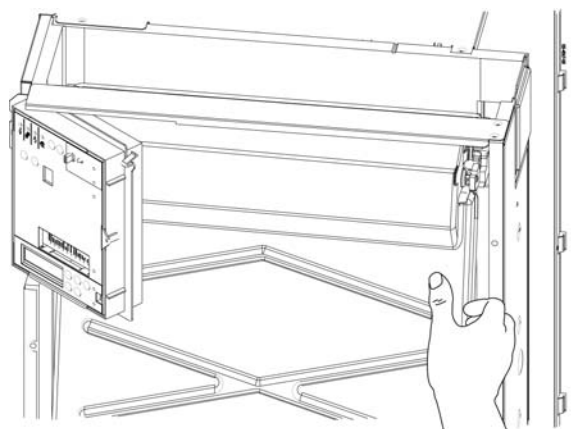

**Release Controller Mounting, Swing Forward.
Release Right Edge of Curtain and Remove**

Use Curtain As a Funnel
When Adding Scale
Remover,

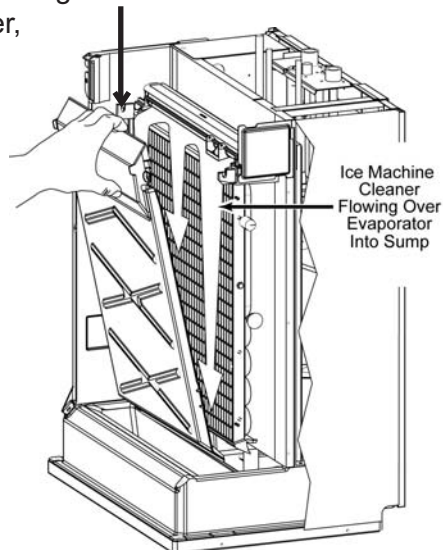

⚠ WARNING	Scotsman Scale Remover contains acids.
	Acids may cause burns. If concentrated cleaner comes in contact with skin, flush with water. If swallowed, do NOT induce vomiting. Give large amounts of water or Milk. Call Physician immediately. Keep out of the reach of children.

Note: Step 6 may be made easier by removing the curtain and using it as a funnel or guide when adding the scale remover to the reservoir. When done return the curtain to its normal position.

Prodigy Eclipse™ 600, 800, 1000

- 7 Allow the ice machine cleaner / scale remover to circulate in the water system for at least 10 minutes.
- 8 Push and release the Clean button again. The yellow Clean light will be on continuously and the machine will drain and refill the reservoir to flush out the ice machine cleaner and residue.
- 9 Allow the drain and refill process to continue for at least 20 minutes.
- 10 Push and release the Off button. The clean cycle will stop and the display will show *0*.
- 15 Locate water level sensor. Squeeze catches together and pull up to remove sensor.
- 16 Wash the metal surfaces of the ice thickness sensor and the adjustment screw with ice machine cleaner solution. Also wash the water distributor, water level sensor probes and curtain with the ice machine cleaner solution.
- 17 Mix a solution of locally approved sanitizer.

Note: If unit has not been de-scaled for an extended period of time and significant mineral scale remains, repeat steps 5 - 10.

- 11 Mix a cleaning solution of 1 oz of ice machine cleaner to 12 ounces of water.
- 12 Remove curtain from unit.
- 13 Locate ice thickness sensor. Squeeze mounting legs together to release sensor.

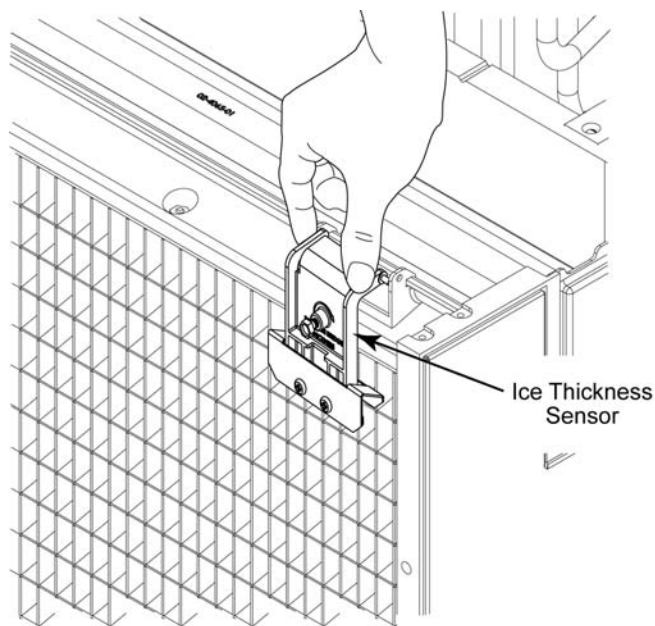

Remove Ice Thickness Sensor

- 14 Remove water distributor from ice machine by disconnecting its hose, squeezing the retaining snaps together and pushing the distributor to the right as far as possible. Lift up to remove. Inspect distributor for restricted orifice holes. Be sure all holes are full open.

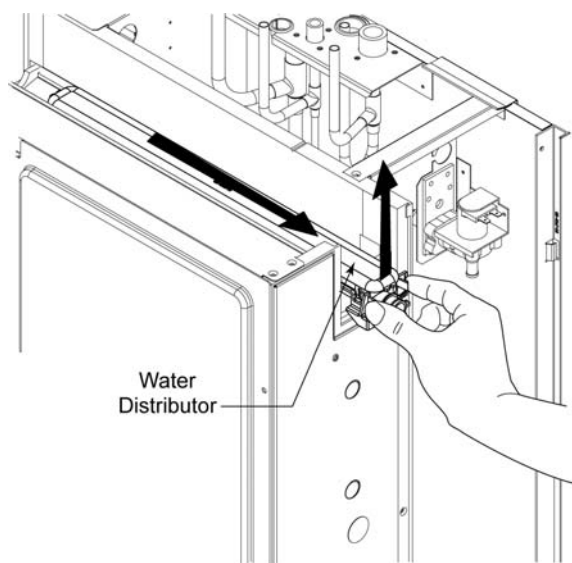

Remove Water Distributor

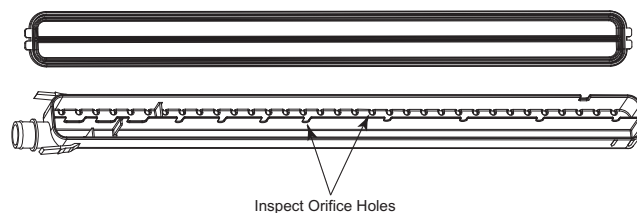

Inspect Water Distributor

Prodigy Eclipse™ 600, 800, 1000

- 18 Thoroughly wash all surfaces of the ice thickness sensor, water level sensor, curtain and water distributor with the sanitizer solution.
- 19 Thoroughly wash all interior surfaces of the freezing compartment, including evaporator frames, evaporator cover and the part of the top panel covering the freezing compartment with the sanitizer solution.
- 20 Return water level sensor, ice thickness sensor, water distributors and curtains to their normal positions. Be sure hose is reattached to water distributor.
- 21 Push and hold the clean button to drain the reservoir. Push and release the clean button again and when the purge valve indicator light goes out, immediately pour the remaining cleaning solution into the reservoir.
- 22 Circulate the sanitizer solution for 10 minutes, then push and release the Clean button.
- 23 Allow the water system to be flushed of sanitizer for at least 20 minutes, then push and release the Off button.
- 24 Return the evaporator cover and front panel to their normal position and secure with the original fasteners.
- 25 Push and release the On button to resume ice making.

Other Maintenance

The remote air cooled condenser coil must be cleaned occasionally to keep the system operating at high efficiency.

⚠ WARNING	Moving Parts Hazard Rotating fan blade can cause cuts
	Disconnect electrical power before removing condenser top or fan guard.

- Remove any large debris from the outside of the coil.
- Vacuum accumulated dust.
- Wash out the coils with water.

Caution: Do NOT use excessive water pressure as that will bend the fins.

- Straighten any damaged fins with a fin comb.
- If the coils have become coated with grease, a coil cleaner will have to be used to wash the coils.

Disconnect power to the condensing unit and remove the condenser top.

- Inspect the fan blade to be sure it is not cracked and is clean.

Return the condenser top to its original position and reconnect the power supply.

Prodigy Eclipse™ 600, 800, 1000

Service Diagnosis

Problem or Symptom	Possible Cause	Probable Correction	
No ice	No power to ice making section	Restore power	
	No power to condensing unit	Restore power	
	No lights on controller	Check transformer	
	Unit manually switched off	Push and release the On button, ask user why it was shut off	
	Power to both sections, controller reset, but condensing unit does not operate		Interconnecting control wire disconnected, reconnect it
			Low or high pressure cut outs open, check system pressures
	No power to compressor contactor coil.		Check toggle switch in CP.
			Check EH222 compressor relay.
	No water to ice making section, controller blinking water light		Restore water supply, check water filters, reset controller
			Check inlet water valve operation
			Check water level sensor
	Ice making section has exceeded maximum freeze time and controller has shut down the system		Condenser coils may need cleaning
			Check condenser fan blade and motor
			Check for excessive air intake temperatures at condenser coil
			Check compressor contactor
			Check compressor and starting components
			Check water pump
			Check purge valve for leak through
			Check vapor inlet valve for leak though
	Ice making section has exceeded maximum harvest time and shut down the system		Check ice making section for lime scale build up, clean as needed
			Check condenser by pass valve
			Check vapor inlet valve*
			Check headmaster
			Check curtain switch
			Check inlet water valve for leak through
			Check for obstruction in ice delivery chute
	CP solenoids do not activate during harvest	Check solenoid relay in EH222	
Bin full code displayed but bin is not full		Check curtain switch	
		Check optional thermostat*	

* Additional diagnostics for this component are on the following pages

Prodigy Eclipse™ 600, 800, 1000

Service Diagnosis

Problem or Symptom	Possible Cause	Probable Correction
No ice	No refrigeration, unit shut down, maximum freeze time code displayed	Check compressor, refrigerant charge, and liquid inlet valve. Note that if liquid inlet valve is not open, compressor will pump down and suction pressure will be very low.
	Sump frozen	Check power supply connection to CP. Power supplied to wrong side of contactor will cause compressor to run all the time.
No water to ice making section	Water level sensor working properly	Clean or replace sensor
Slow ice release during harvest	Cubes are too large	Check ice thickness sensor
		Check for water leak
	Condenser by-pass valve does not open	Check coil of valve
		Check power to valve during harvest
No ice sensed during harvest	Ice sensing system failure	Check curtain switch
	No ice released to bin	Ice outlet blocked - check for obstruction
	No ice released, vapor inlet valve does not open	Check coil for continuity, if open replace coil
		Check for 24 volts to coil during harvest, if non, check at relay in EH222
		Check low side pressure, if pressure does not rise during harvest, and valve is electrically OK, replace vapor inlet valve

Prodigy Eclipse™ 600, 800, 1000

Service Diagnosis

Problem or Symptom	Possible Cause	Probable Correction
Low capacity	Dirty condenser	Clean condenser
	Air temperature intake to condenser very high	Re-orient condenser to avoid hot air intake
	Water temperature intake to ice making section very high	Check for hot water supply to ice machine due to mal-functioning or non-existent hot water check valve at dishwashing sink
	Ice broken up and stuck between reservoir and curtain, happens almost every cycle	Ice thickness set too thin
		Ice very uneven, check superheat
		Slow harvest, check headmaster
	Storage bin or dispenser not holding ice properly	Check drains for water flow from ice machine (separate to correct) or restriction
	High volume of drinks dispensed, cold plate melting ice	Suggest pre-cooler for water supply to cold plate
Vapor inlet valve leaks through slightly during the freeze cycle	Check valve body for similar temperatures on inlet and outlet, the outlet should be colder and frost develops on the tubes to the evaporators	
Exceeding maximum freeze time, compressor unit trips on high discharge temp	Check condenser bypass valve	
Poor ice formation - very cloudy and misshapen	Dirty water system	Clean the water distributor to remove built up mineral scale
	Low refrigerant charge.	Add several pounds of refrigerant to check. If low on charge, locate leak. Recover refrigerant, repair leak, replace drier, evacuate to 300 microns and weigh in the nameplate charge.
Whistling noise at CP unit during harvest	By pass and liquid inlet valve coils not getting power	Check harness

Prodigy Eclipse™ 600, 800, 1000

Operational Characteristics **600** lb system

Cycle Times @ Condenser Temp/Cabinet Temp/Water Temp in degrees F

	70/70/50	90/90/70	120/110/100
Freeze	13 to 15 minutes	16 to 18 minutes	29 to 31 minutes
Harvest	1 to 1.5 minutes	1 to 1.5 minutes	.5 to 1 minutes

System Pressures @ Condenser Temp/Cabinet Temp/Water Temp in degrees F.

	70/70/50	90/90/70	120/110/100
Suction at Ice Making Section, end of Freeze	29 to 34 PSIG	30 to 35 PSIG	34 to 39 PSIG
Suction at Ice Making Section, Harvest - peak	103 to 125 PSIG	120 to 140 PSIG	160 to 180 PSIG
Discharge at Condensing Unit: Freeze - 5 min	235 to 255 PSIG	240 to 260 PSIG	345 to 365 PSIG

Headmaster maintains a minimum discharge pressure during freeze of:

- 217 PSIG + 25, -15 PSIG

CPR Valve Setting: 55 - 60 PSIG.

Note: CPR allows a maximum low side pressure at the CP unit's compressor. Maximum only occurs during harvest.

Refrigerant Charge

- 232 oz

Compressor Amps

- Single Phase - 5 to 7

Batch Weight

- 8 lb

Discharge Pressure Cut Out Switch

- Cuts Out at: 450 PSIG
- Resets at: 350 PSIG

Compressor: RS70C1E

Prodigy Eclipse™ 600, 800, 1000

Operational Characteristics **800** lb system

Cycle Times @ Condenser Temp/Cabinet Temp/Water Temp in degrees F.

	70/70/50	90/90/70	120/110/100
Freeze	10 to 12 minutes	13 to 15 minutes	19 to 21 minutes
Harvest	1 to 1.5 minutes	1 to 1.5 minutes	.5 to 1 minute

System Pressures @ Condenser Temp/Cabinet Temp/Water Temp in degrees F

	70/70/50	90/90/70	120/110/100
Suction at Ice Making Section, end of Freeze	26 to 31 PSIG	26 to 31 PSIG	30 to 35 PSIG
Suction at Ice Making Section, Harvest - Peak	85 to 105 PSIG	105 to 125 PSIG	140 to 160 PSIG
Discharge at Condensing Unit: Freeze - 5 minutes in	230 to 250 PSIG	250 to 270 PSIG	330 to 350 PSIG

Headmaster maintains a minimum discharge pressure during freeze of:

- 217 PSIG + 25, -15 PSIG

CPR Valve Setting: 55 - 60 PSIG.

Note: CPR allows a maximum low side pressure at the CP unit's compressor. Maximum only occurs during harvest.

Refrigerant Charge

- 232 oz

Compressor Amps

- Single Phase - 6 to 8
- Three Phase - 5 to 7

Batch Weight: 8 lb

Discharge Pressure Cut Out Switch

- Cuts Out at: 450 PSIG
- Resets at: 350 PSIG

Prodigy Eclipse™ 600, 800, 1000

Operational Characteristics 1000 lb system

Cycle Times @ Condenser Temp/Cabinet Temp/Water Temp in degrees F

	70/70/50	90/90/70	120/110/100
Freeze	6 to 8 minutes	8 to 10 minutes	16 to 18 minutes
Harvest	1 to 1.5 minutes	1 to .5 minutes	.5 to 1 minutes

System Pressures @ Condenser Temp/Cabinet Temp/Water Temp in degrees F

	70/70/50	90/90/70	120/110/100
Suction at Ice Making Section, end of Freeze	26 to 31 PSIG	27 to 32 PSIG	30 to 35 PSIG
Suction at Ice Making Section, Harvest	85 to 105 PSIG	90 to 110 PSIG	140 to 160 PSIG
Discharge at Condensing Unit: Freeze - 5 minutes in	230 to 250 PSIG	230 to 250 PSIG	345 to 365 PSIG

Headmaster maintains a minimum discharge pressure during freeze of:

- 217 PSIG + 25, -15 PSIG

CPR Valve Setting: 55 - 60 PSIG.

Note: CPR allows a maximum low side pressure at the CP unit's compressor. Maximum only occurs during harvest.

Refrigerant Charge

- 272 oz

Compressor Amps

- Single Phase 8 to 10
- Three Phase 5 to 7

Batch Weight: 8 lb

Discharge Pressure Cut Out Switch

- Cuts Out at: 450 PSIG
- Resets at: 350 PSIG

Prodigy Eclipse™ 600, 800, 1000

Refrigeration System Service

Recovery

Recovery must be done from the condensing unit, but requires the ice machine to be shut down.

1. At the ice making section, remove the front panel.
2. Push and release the Harvest button. When the machine shuts off, recover the refrigerant.
3. Remove compressor package covers.
4. Attach recovery system to low side (compressor process port valve)
5. If the recovery system can recover liquid, attach recovery system to high side (receiver liquid line out valve)

Operate recovery system to remove refrigerant from the system. No other points of attachment or solenoid activation are required.

Vapor Inlet Valve - Replacement of the valve body.

Note: The coil and internal components are available to repair the valve without replacing the valve body.

1. Recover refrigerant as outlined above.
2. Unplug ice making section from power supply.
3. Disconnect wire harness from valve coil.
4. Disconnect wire harnesses from controller.
5. Disconnect wire harnesses and ground wire from inlet water valve and purge valve.
6. Cut tie wraps securing wire water valve harnesses to other wires.
7. Remove four screws holding control box and controller mounting bracket to ice making section. Gently re-position assembly away from vapor inlet valve. Support with wire.
8. Cut tie wraps holding vapor inlet valve to bracket and move valve away from plastic housing.

Note: When using torch, cover plastic behind valve with a small piece of sheet metal to protect it while brazing.

9. Cut out or heat joints with torch to melt the braze joints and remove valve body.
10. Reverse to reassemble.

11. Replace liquid line drier in CP unit.
12. Evacuation system to 300 microns.
13. Weigh in the nameplate charge.
14. Start unit and check operation.
15. Return all covers to their normal positions and secure with the original screws.