

## F0822 – 800 lb Flake Ice Machine

### Prodigy® Flake Ice Machine



Shown on B322S bin with optional KLP8S legs.

### Features

**AutoAlert™ indicator lights** constantly communicate about operating status and actually signal your staff when it's time to descale, sanitize and more - making upkeep practically foolproof.

**Preventative maintenance is simpler** than ever with easily-removed panels allowing clear access to internal components and a diagnostic code display insuring the right fix the first time. Reusable air filter is easily removable from the outside.

Flake ice is ideal for keeping salad bar fruits and veggies crisp and appealing and soft drink displays icy cold.

An optional **advanced feature Smart-Board™** provides NAFEM data protocol and additional operational data that can be displayed on-screen or transmitted remotely, resulting in early alert and fast diagnosis of operating issues.

An optional **Vari-Smart™ ultrasonic ice level control** sensor allows you the flexibility to program ice levels, for up to 7 days, keeping just the right amount of freshly made ice in the bin.

**Industry leading 3 year parts and labor warranty**

### 24 Hour Volume Production

Air Cooled			Remote Cooled			Water Cooled		
70°F/21°C 50°F/10°C lb/kg	Air Water	90°F/32°C 70°F/21°C lb/kg	70°F/21°C 50°F/10°C lb/kg	Air Water	90°F/32°C 70°F/21°C lb/kg	70°F/21°C 50°F/10°C lb/kg	Air Water	90°F/32°C 70°F/21°C lb/kg
800/363		580/263	760/345		610/277	775/352		620/281



### Modular Bin Options

Model Number	Dimensions W" x D" x H"	Application Capacity lb/kg	AHRI Certified Bin Capacity lb/kg	Finish	Ship Weight lb/kg
B322S	22 x 34 x 44**	370/168	290/132	SS	140/64
B330P*	30 x 34 x 31**	344/156	270/123	Poly	90/41
B530P*	30 x 34 x 44**	536/244	420/191	Poly	110/50
B530S*	30 x 34 x 44**	536/244	420/191	SS	150/68
B842S*	42 x 34 x 44**	778/353	610/277	SS	185/84
B948S*	48 x 34 x 44**	893/406	700/319	SS	220/100

\*Contact Scotsman for bin top requirements. \*\* Add 6" H for bin legs.



Bin: B530S



Bin: B842S

### Flake Ice



Cools more quickly than other ice forms. Ideal for seafood and produce displays

### Warranty

- 3 years parts and labor on all components.
- 5 years parts on the compressor.

Warranty valid in North, South & Central America. Contact factory for warranty in other regions.

# Scotsman®

The smart choice in ice.™

# F0822 - 800 lb Flake Ice Machine

\* Installation Note: Allow 6" minimum space at back for utility connections.

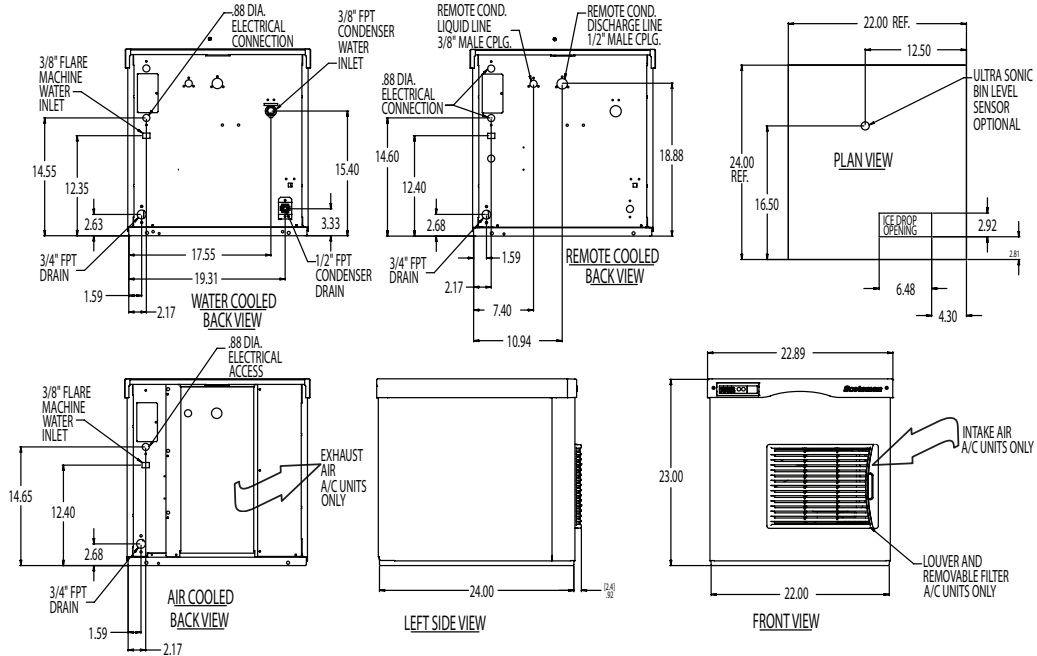

## Specifications

Model Number	Condenser Unit	Basic Electrical Volts/Hz/Phase	Max. Fuse Size (amps)	Circuit Wires	Min. Circuit Ampacity	Energy Consumption kWh/100 lb (45.4 kg) 90°F(32°C)/70°F(21°C)	Water Usage Gallons/100 lb (liters/45.4 kg)	
							Potable 90°F(32°C)/70°F(21°C)	Condenser 90°F(32°C)/70°F(21°C)
F0822A-1A	Air	115/60/1	25	2	18.3	4.7	12.0/45.5	-
F0822R-1A	Remote	115/60/1	25	2	19.4	5.1	12.0/45.5	-
F0822W-1A	Water	115/60/1	25	2	16.7	3.9	12.0/45.5	82/310.73
F0822A-32A	Air	208-230/60/1	15	2	9.8	4.7	12.0/45.5	-
F0822W-32A	Water	208-230/60/1	15	2	8.9	3.9	12.0/45.5	82/310.73

## All Models

Dimensions (W x D x H):  
Unit: 22.9" x 24" x 23"  
(58.2 x 61.0 x 58.4 cm)

Shipping Carton:  
25.5" x 27.5" x 28.5"  
(64.8 x 69.9 x 72.4 cm)

Shipping Weight:  
175 lb/79 kg

BTU per hour:  
7,100

Refrigerant:  
R-404A

## Accessories

Model Number	Description
KVS	Vari-Smart™ Ice Level Control - Program ice bin levels to match ice needs.
KSBU	Smart-Board™ Advanced Control - Use additional operational data for fast diagnosis.
KSBU-N	Smart-Board™ Advanced Control with Network - Network capable.
KPFSA223	Side Air Flow Kit for 23" Tall Prodigy Flaker and Nugget
ERC111-1A	Remote Condenser for F0822R, 115/60/1 - Consult Remote Condenser Spec Sheet for details.
RTE10	Line Set, Pre-Charged, R404A, 10 ft.
RTE25	Line Set, Pre-Charged, R404A, 25 ft.
RTE40	Line Set, Pre-Charged, R404A, 40 ft.
RTE75	Line Set, Pre-Charged, R404A, 75 ft.

\* Scotsman recommends all ice machines have water filtration. See Scotsman Sanitation Matrix for details.

## Operating Requirements

	Minimum	Maximum
Air Temperatures	50°F (10°C)	100°F (38°C)
Water Temperatures	40°F (4.4°C)	100°F (38°C)
Remote Cond. Temps	-20°F (-29°C)	120°F (49°C)
Water Pressures	20 PSIG (1.4 bar)	80 PSIG (5.5 bar)
Electrical Voltage	-10%	+10%

Specifications and design are subject to change without notice.

Scotsman Ice Systems  
775 Corporate Woods Parkway  
Vernon Hills, IL 60061

1-800-SCOTSMAN  
Fax: 847-913-9844  
E-mail: customer.service@scotsman-ice.com

[www.scotsman-ice.com](http://www.scotsman-ice.com)