

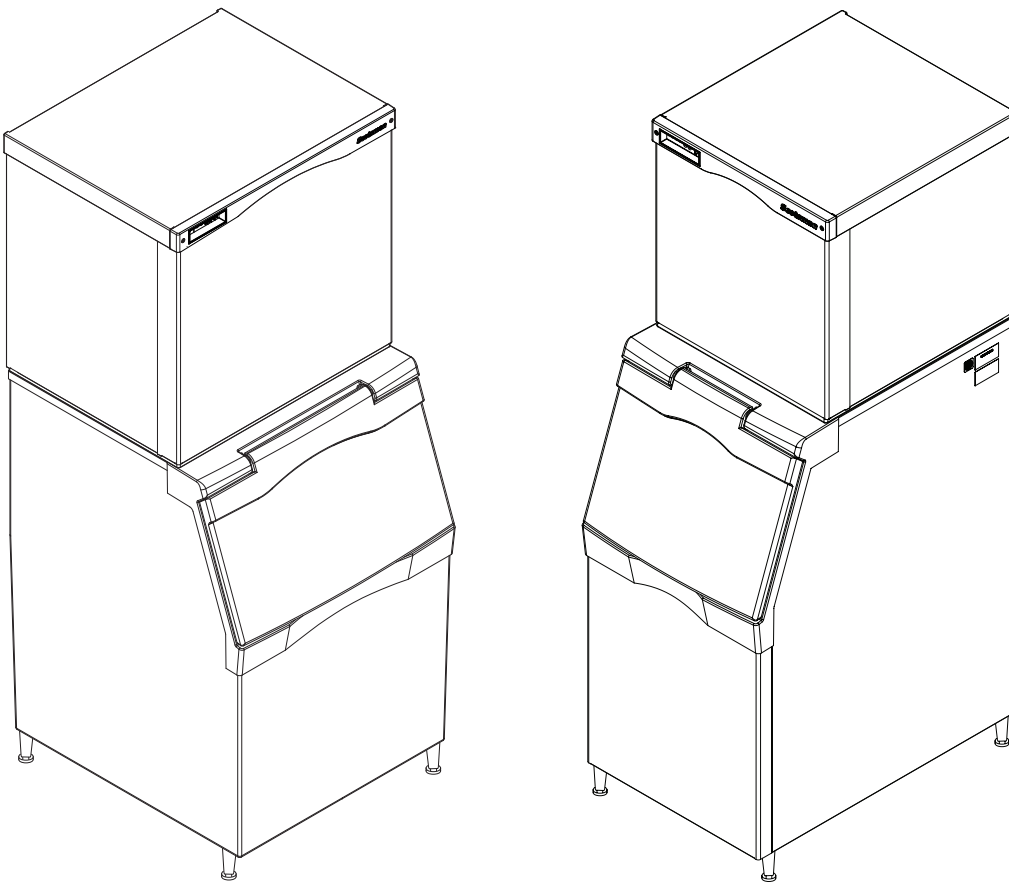

# Installation and User's Manual for Modular Cuber

Models C0322, C0522, C0722, C0330, C0530,  
C0630, C0830 and C1030



# C0322 through C1030

## Air and Water Cooled User Manual

### Introduction

---

The design of this modular cuber is the result of years of experience and testing. Standard features include front accessible indicator lights and on-off switches that provide the user with fast access to critical information and easy operational control.

Keep this manual for future reference.

This installation and user manual is divided into three main sections: Installation, which provides the trade person with the information needed to set up and install this product; Use and Operation, which provides the user with the information to use the product; and Maintenance, which provides the user with the information needed keep it operating efficiently.

#### Contents

Introduction . . . . .	Page 1
Installation: Product Specifications . . . . .	Page 2
Model Number Description . . . . .	Page 3
Product Description & Electrical Requirements . . . . .	Page 4
C0322 and C0522 Cabinet Layout . . . . .	Page 5
C0330, C0530, C0630 and C1030 Cabinet Layout . . . . .	Page 6
C0722 Cabinet Layout. . . . .	Page 7
Water . . . . .	Page 8
Panel Removal . . . . .	Page 9
Plumbing Requirements . . . . .	Page 10
Electrical. . . . .	Page 11
Final Check List . . . . .	Page 12
Initial Start Up . . . . .	Page 13
Adjustments . . . . .	Page 14
Use and Operation . . . . .	Page 15
Control Switches. . . . .	Page 16
Options . . . . .	Page 17
Cleaning, Sanitation and Maintenance . . . . .	Page 18
Air cooled condenser filter. . . . .	Page 20
What to do before calling for service . . . . .	Page 21

Note any Caution or Warning symbols when they appear on the product or in this manual. They indicate potential hazards.

**▲WARNING ▲CAUTION**

**C0322 through C1030  
Air and Water Cooled User Manual  
Installation: Product Specifications**

**Location Limitations:**

The product is designed to be installed indoors, in a controlled environment. Air cooled models discharge very warm air into the room out the back. Space must be allowed at the left side and back for air intake and discharge. Water cooled models discharge warm water into the building's drain.

Space needs to be provided on both sides and above for service access.

**Space Limitations**

Note: Although the machine will function, ice capacity of air cooled machines will be significantly reduced with minimal clearance at the sides, back and top. Some space is recommended for service and maintenance purposes on all models. 6" of space at the sides and back are required for adequate operation. To get the most capacity, locate the machine away from heat producing appliances and heating ducts, and keep the left side away from any wall, **allow 12-18 inches of space at the left for good air flow.**

Airflow is in the left side, out the back (as viewed from the front).

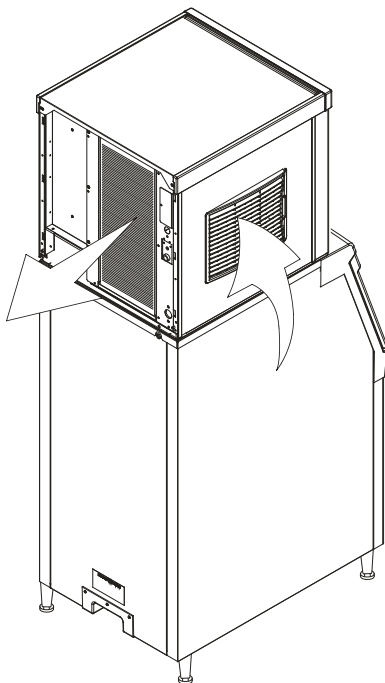

Air Flow

**Environmental Limitations**

	Minimum	Maximum
Air temperature	50°F.	100°F.
Water temperature	40°F.	100°F.
Water pressure	20 psi	80 psi

**Power supply – acceptable voltage ranges**

	Minimum	Maximum
115 volt model	104 volts	126 volts
230 volt model	198 volts	253 volts

**Warranty Information**

The warranty statement for this product is provided separately from this manual. Refer to it for applicable coverage. In general warranty covers defects in material or workmanship. It does not cover maintenance, corrections to installations, or situations when the machine is operated in circumstances that exceed the limitations printed above.

**Product Information**

The product is a modular cuber. That type of machine is designed to be placed on an ice storage bin or an ice dispenser. Many installations only require the matching bin, but some also require an adapter to be placed between the bin and the cuber or between the dispenser and the cuber. This product cannot be stacked. See the chart for application information.

**C0322 through C1030**  
**Air and Water Cooled User Manual**  
**Model Number Description**

**Example:**

- C0322SA-1B
- C= cuber
- 03= nominal ice capacity in 100s of pounds
- 22= nominal width of cabinet
- S= Cube size. S=small or half dice cube.  
M=medium or full dice cube
- A=Condenser type. A=air cooled. W=water cooled
- -1=115 60 Hz, -32=208-230 60 Hz, -3= 208-230 3 phase 60 Hz
- B=Series revision code. B=second series

Note: Listed model numbers typically include only the first five characters of the model number.

**Options:**

There are several field-installed options that can be installed at initial start up or later. They include:

- KVS, Vari-Smart Adjustable ice level system.
- KSB, SmartBoard Advanced feature board.
- KPMFA223-B, front air flow panel. Fits C0322 and C0522. B series.
- KPMFA303-B, front air flow panel. Fits C0330, C0530, C0630. B or C series.
- KPFMA309-B, front air flow panel. Fits C0830 and C1030. B series.
- A39514-021 air baffle for corner locations. Fits C0322, C0330, C0522, C0722, C0530, C0630.
- A39515-021, air baffle for corner locations. Fits C0830 and C1030.

Some installations require bin or dispenser adapters.

**Standard Bin Applications - Adapter information.**

Model	B222 B322	B530P, B330P, B530S, HTB555	BH800, BH801, B842S	BH900, B948S
C0322, C0522, C0722	Direct fit	KBT27	Not available	Not available

C0530, C0630, C0830, C1030	Does not fit	Direct fit	KBT28	KBT22
-------------------------------------	--------------	------------	-------	-------

**Hotel Dispensers**

The HD22 and HD30 are compatible with this ice machine, no adapters are needed. Some typical combinations include:

- HD22 – use with C0322 or C0522
- HD30 – use with C0330 or C0530

Note: All models ship with the On and Off switches front accessible. If desired, the On and Off switches can be covered but by changing the bezel in the front panel's trim strip, available from a local distributor.

**Ice and Beverage Dispensers – Adapter information**

Model	ID150	ID200 or ID250
C0322, C0522, C0722	KBT42	KBT43
C0530, C0630, C0830, C1030	Does not fit	KBT44

**Other Bins & Applications:**

Note the drop zone and ultrasonic sensor locations in the illustrations on the next pages.

Scotsman ice systems are designed and manufactured with the highest regard for safety and performance.

Scotsman assumes no liability of responsibility of any kind for products manufactured by Scotsman that have been altered in any way, including the use of any part and/or other components not specifically approved by Scotsman.

Scotsman reserves the right to make design changes and/or improvements at any time. Specifications and design are subject to change without notice.

**C0322 through C1030**  
**Air and Water Cooled User Manual**  
**Product Description & Electrical Requirements**

Dimensions w" x d" x h"	Model	Series	Electrical volts/Hz/ phase	Condenser	Minimum Circuit Ampacity	Maximum Fuse Size*	
22.75** x 24 x 23	C0322SA-1	A or B	115/60/1	Air	12.7	15	
	C0322SW-1	A or B	115/60/1	Water	11.9	15	
	C0322SA-32	A or B	208-230/60/1	Air	6.1	15	
	C0322SW-32	A or B	208-320/60/1	Water	5.6	15	
	C0522SA-1	A or B	115/60/1	Air	13.8	15	
	C0522SW-1	A or B	115/60/1	Water	12.2	15	
	C0522SA-32	A or B	208-230/60/1	Air	7.6	15	
	C0522SW-32	A or B	208-230/60/1	Water	6.7	15	
30.75** x 24 x 23	C0330SA-1	A or B or C	115/60/1	Air	12.7	15	
	C0330SW-1	A or B or C	115/60/1	Water	11.9	15	
	C0330MA-32	A or B or C	208-230/60/1	Air	6.1	15	
	C0330SW-32	A or B	208-230/60/1	Water	5.6	15	
	C0530SA-1	A or B	115/60/1	Air	13.9	15	
	C0530SW-1	A or B	115/60/1	Water	12.2	15	
	C0530SA-32	A or B	208-230/60/1	Air	7.9	15	
	C0530SW-32	A or B	208-230/60/1	Water	6.7	15	
	C0530SA-1	C	115/60/1	Air	15.2	20	
	C0530SW-1	C	115/60/1	Water	13.5	15	
	C0530SA-32	C	208-230/60/1	Air	7.8	15	
	C0530SW-32	C	208-230/60/1	Water	6.6	15	
	C0630SA-32	A or B	208-230/60/1	Air	18.2	20	
	C0630SW-32	A or B	208-230/60/1	Water	17	20	
	22.75** x 24 x 29	C0722SA-32	B	208-230/60/1	Air	10	15
	30.75** x 24 x 29	C0830SA-32	A or B	208-230/60/1	Air	10.2	15
C0830SW-32		A or B	208-230/60/1	Water	9	15	
C0830SA-3		A or B	208-230/60/3	Air	8.4	15	
C0830SW-3		A or B	208-230/60/3	Water	7.2	15	
C1030SA-32		A or B	208-230/60/1	Air	16	20	
C1030SW-32		A or B	208-230/60/1	Water	14.8	15	
C1030SA-3		A or B	208-230/60/3	Air	11	15	
C1030SW-3		A or B	208-230/60/1	Water	9.8	15	

Table notes: Medium cube models have the same electrical characteristics as Small. Series revision code omitted.

\* Or HACR type circuit breakers.

\*\* Maximum width at top panel. Air cooled models add .75" for left side louvers.

**C0322 through C1030**  
**Air and Water Cooled User Manual**  
**C0322 and C0522 Cabinet Layout**

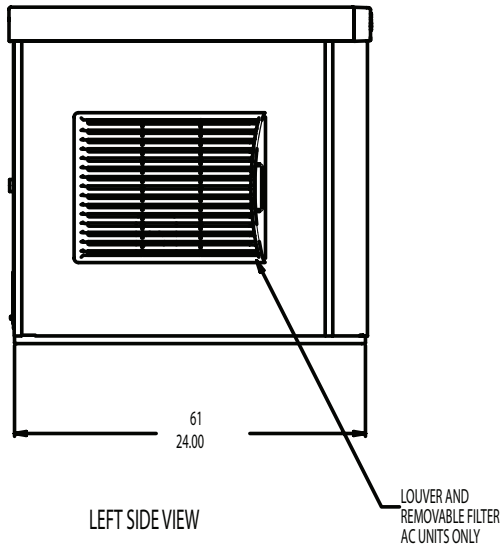

C0322, C0522 Air Cooled Side View

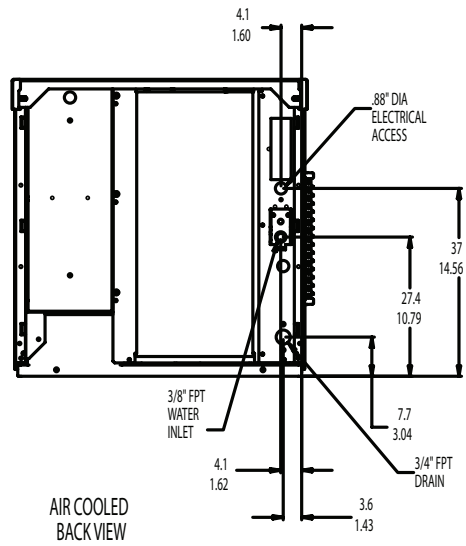

C0322, C0522 Air Cooled Back View

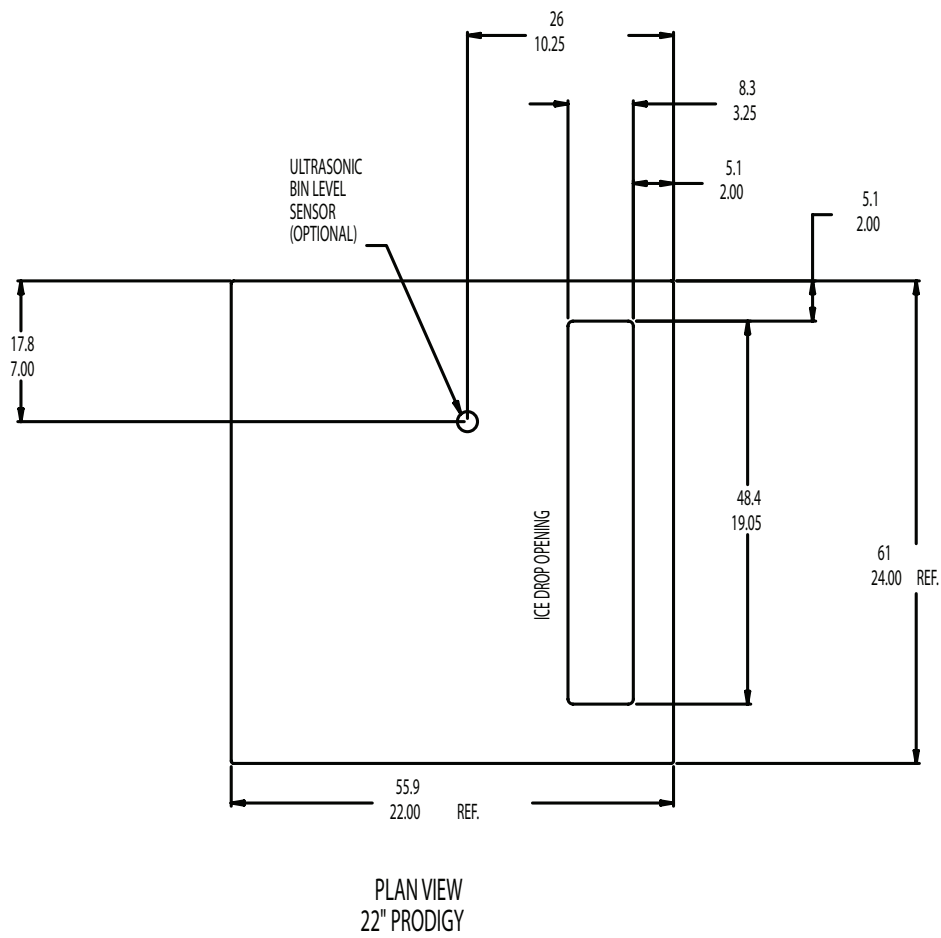

C0322, C0522, C0722 Top View

**C0322 through C1030**  
**Air and Water Cooled User Manual**  
**C0330, C0530, C0630 and C1030 Cabinet Layout**

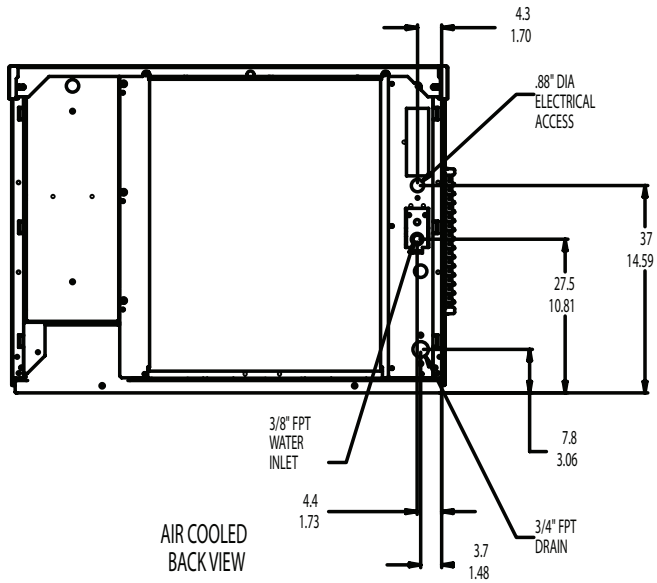

C0330, C0530, C0630 Air Cooled Back View

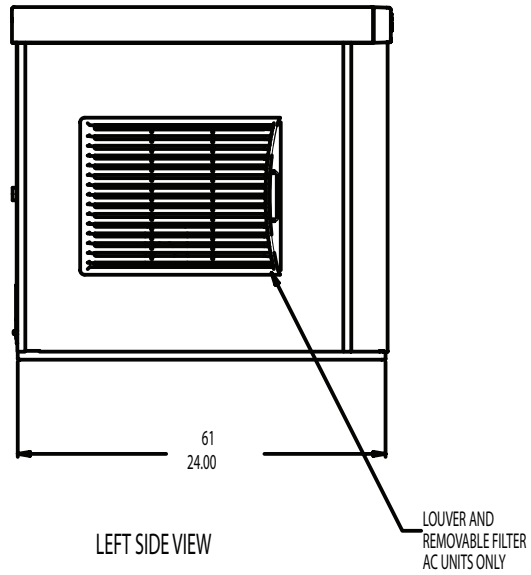

C0330, C0530, C0630 Air Cooled Side View

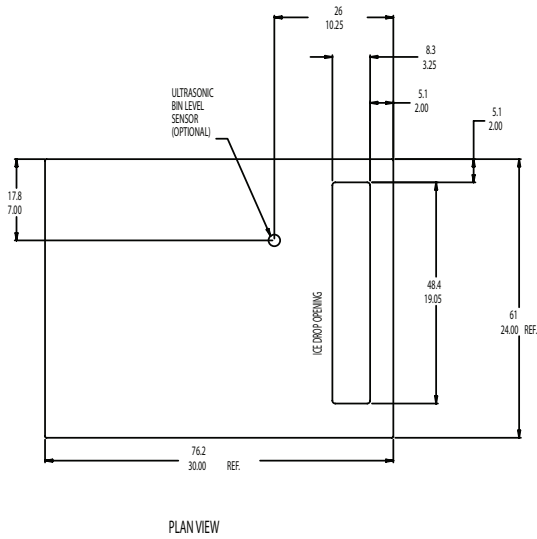

C0330, C0530, C0630, C0830, C1030 Top View

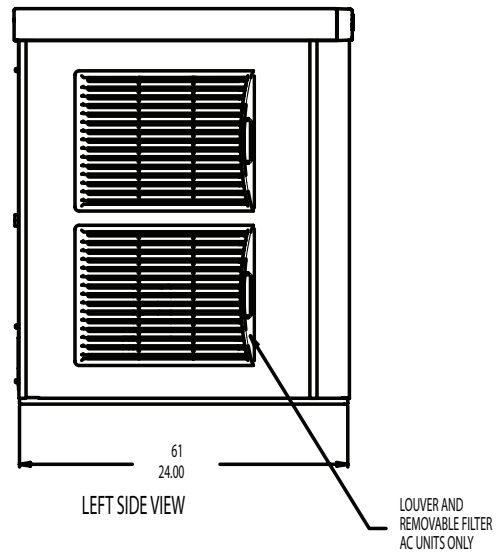

C0722, C0830, C1030 Air Cooled Side View

**C0322 through C1030**  
**Air and Water Cooled User Manual**  
**C0722 Cabinet Layout**

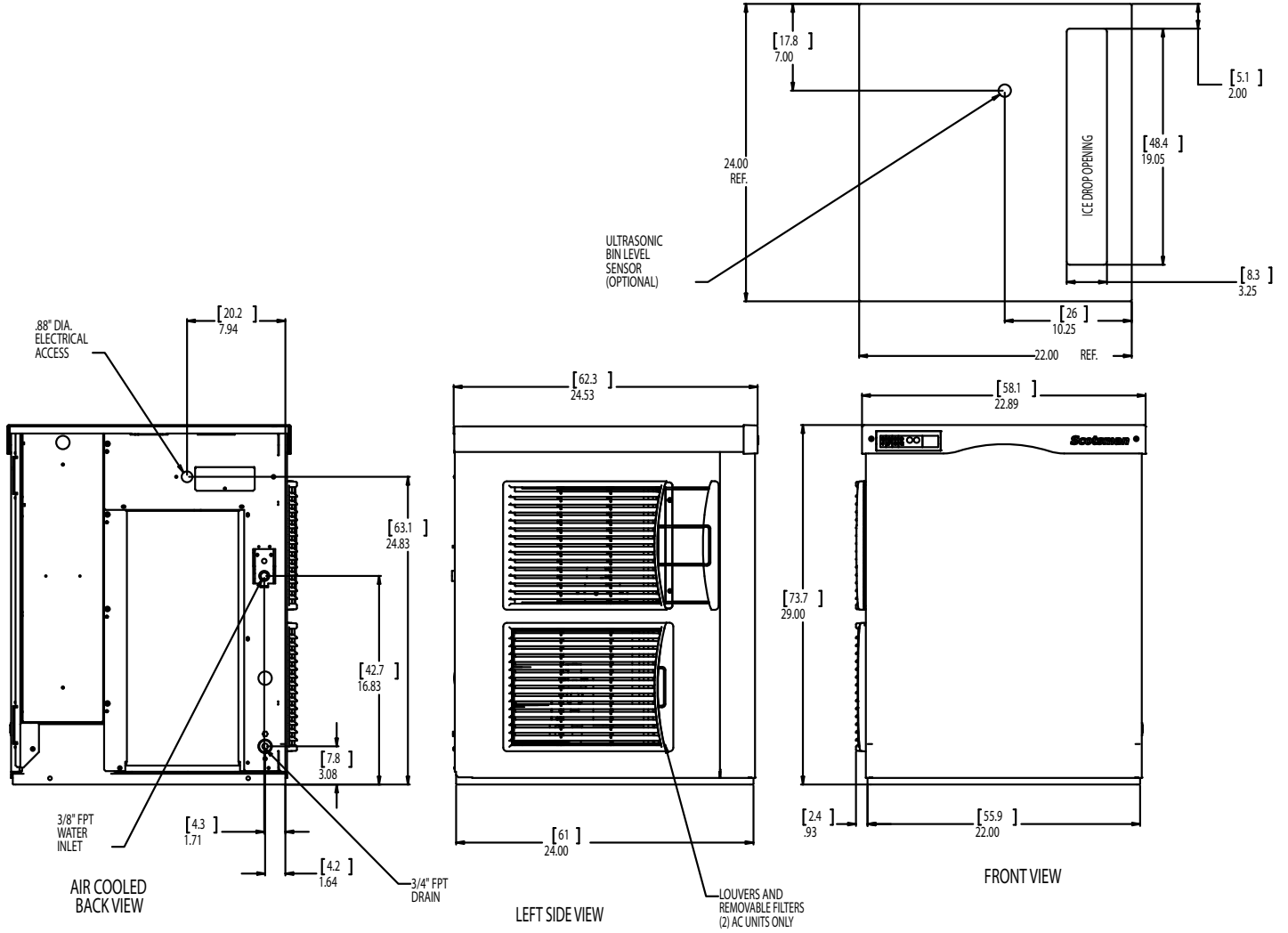



## **C0322 through C1030**

### **Air and Water Cooled User Manual**

#### **Water**

---

The quality of the water supplied to the ice machine will have an impact on the time between cleanings and ultimately on the life of the product. Water can contain impurities either in suspension or in solution. Suspended solids can be filtered out. In solution or dissolved solids cannot be filtered, they must be diluted or treated. Water filters are recommended to remove suspended solids. Some filters have treatment in them for suspended solids. Check with a water treatment service for a recommendation.

#### **RO Water**

This machine can be supplied with Reverse Osmosis water, but the water conductivity must be no less than 10 microSiemens/cm.

#### **Potential for Airborne Contamination**

Installing an ice machine near a source of yeast or similar material can result in the need for more frequent sanitation cleanings due to the tendency of these materials to contaminate the machine.

Most water filters remove chlorine from the water supply to the machine which contributes to this situation. Testing has shown that using a filter that does not remove chlorine, such as the Scotsman Aqua Patrol, will greatly improve this situation, while the ice making process itself will remove the chlorine from the ice, resulting in no taste or odor impact. Additionally, devices intended to enhance ice machine sanitation, such as the Scotsman Aqua Bullet, can be placed in the machine to keep it cleaner between manual cleanings

#### **Water purge**

Cube ice machines use more water than what ends up in the bin as ice. While most water is used during ice making, a portion is designed to be drained out every cycle to reduce the amount of hard water scale in the machine. That's known as water purge, and an effective purge can increase the time between needed water system cleaning. In addition, this product has the capability to automatically vary the amount of water purged based on the purity of the water supplied to it. The water purge rate can also be set manually. Adjustments of purge due to local water conditions are not covered by warranty.

# C0322 through C1030

## Air and Water Cooled User Manual

### Panel Removal

1. Locate and loosen the two screws at the front edge of the top panel.
2. Pull the front panel out at the top until it clears the top panel.
3. Lift the front panel up and off the machine.
4. Remove two screws at the front of the top panel. Lift up the front of the top panel, push the top panel back an inch, then lift to remove.
5. Locate and loosen the screw holding each side panel to the base. Left side panel also has a screw holding it to the control box.
6. Pull the side panel forward to release it from the back panel.

This manual covers several models. The model number on the product is located in two places, on the back dataplate and on the model and serial number tag, located behind the front panel. See the illustration for the dataplate and serial tag locations.

Write the model and serial number of this product here:

---

Write the day, month and year of initial start up here:

---

### Switch Bezel

All models ship with the On and Off switches front accessible. If desired, the On and Off switches can be covered up to prevent unauthorized use by changing the bezel in the front panel's trim strip. A cover up bezel is available from the local Scotsman distributor.

Push snaps of standard bezel in and pull the bezel out of the front panel trim strip.

Locate other bezel. Push into the trim strip from the front until it snaps into place. Return the front panel to its original position and secure it to the cabinet.

### Uncrate and Set Up

Begin with unpacking the ice storage bin. Remove the

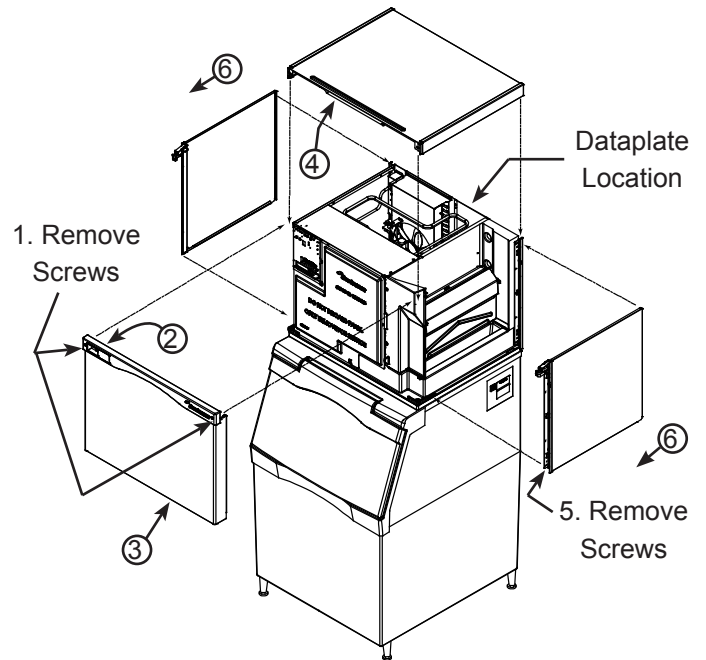

Dataplate Location and Panel Removal

carton, and using part of the carton as a cushion, tip the bin on its back to remove the skid and attach the legs or casters.

Return the bin to an upright position. Check the bin top gasket for gaps and tears, fill any in with food grade sealant prior to placing the ice machine on the bin.

Install the bin top adapter or ice dispenser adapter, if one is required for the application.

If the ice machine has not been unpacked, do so now. Remove the carton from the skid. Lift the ice machine off the skid directly onto the bin.

**Note:** The machine is heavy! Use a mechanical hoist if necessary.

Secure the ice machine to the bin with the hardware provided (two metal straps and 4 bolts).

Place the bin and ice machine in the selected location and level it by adjusting the bin leg levelers.

# C0322 through C1030

## Air and Water Cooled User Manual

### Plumbing Requirements

All models require connection to cold, potable water. A hand actuated valve within site of the machine is required. Air cooled models have a single 3/8" FPT inlet water connection; a 3/8" FPT to 3/8" male flare adapter is available from the local Scotsman distributor or from a hardware store.

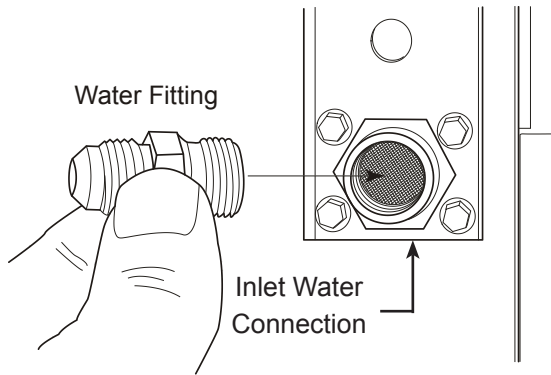

Water cooled models have a 1/2" FPT drain fitting plus an additional 3/8" FPT condenser inlet water connection.

#### Water Filters

If connecting to water filtration, filter only the water to the reservoir, not to the condenser. Install a new cartridge if the filters were used with a prior machine.

All models require drain tubing to be attached to them. Air cooled models have a single 3/4" FPT drain fitting in the back of the cabinet. Water cooled models have the same fitting plus an additional 1/2" FPT drain fitting in the back of the cabinet.

Install new tubing when replacing a prior ice machine, as the tubing will have been sized for the old model and might not be correct for this one.

1. Connect water supply to water inlet fittings. 3/8" OD tubing is recommended.

Note: This NSF listed model has a 1" anti-back flow air gap between the water inlet tube end and the highest possible reservoir water level, no back flow device is required for the potable water inlet.

2. Connect drain tubing to drain fittings.
3. Route the drain tubing to building drain. Follow local codes for air gap.

#### Drain Tubing:

Use rigid drain tubes and route them separately – do not Tee into the bin's drain and, if water cooled, do not Tee the condenser drain into the reservoir or bin drain.

Vent the reservoir drain. A vertical vent at the back of the drain, extended about 8 - 10" will allow the gravity drain to empty and also keep any surges during draining from discharging water out the vent.

Horizontal runs of drain tubing need a 1/4" fall per foot of run for proper draining.

Follow all applicable codes.

Water Cooled Shown, Air Cooled Similar

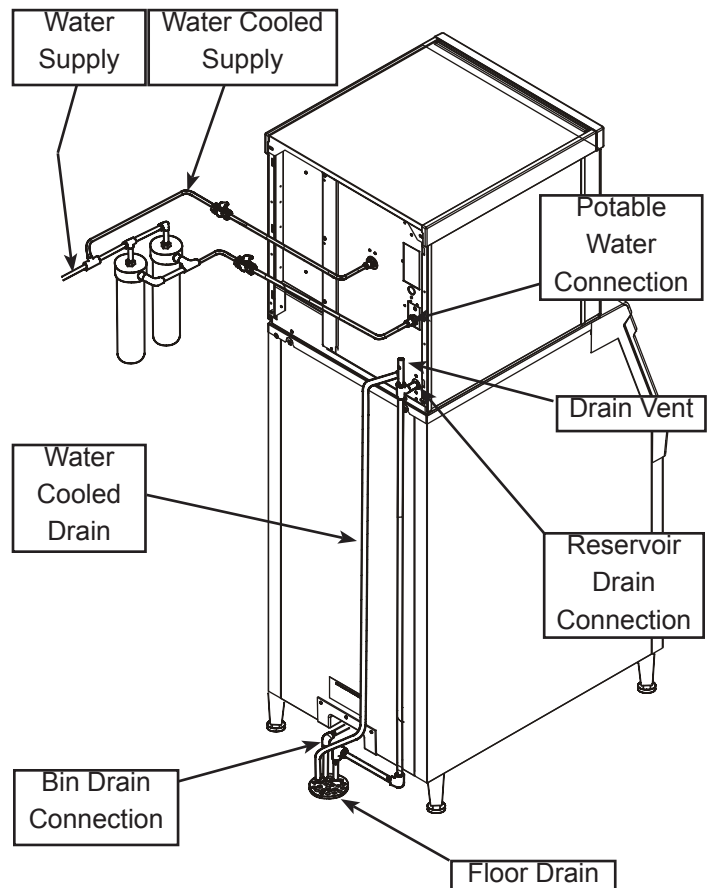

Plumbing Connections

# C0322 through C1030

## Air and Water Cooled User Manual

### Electrical

---

The machine is not supplied with a power cord as the machine is designed to be permanently connected.

The dataplate on the back of the cabinet details the power requirements, including voltage, phase, minimum circuit ampacity and maximum fuse size.

HACR type circuit breakers may be used in place of fuses. Extension cords are not permitted. Use of a licensed electrician is recommended.

Electrical connections are made inside the junction box in the back panel of the ice machine.

1. Remove the junction box cover and route the electrical supply cable through the access hole and properly attach the power supply wires to the leads in the junction box.
2. Install a field supplied strain relief per code. Attach a ground wire to the ground connection in the junction box.
3. Check voltage when complete.
4. Return the junction box cover to its original position and secure with the original screws.

The electrical disconnect switch with fuse protection must be a two pole type with a minimum of 3 mm between open contacts.

Follow all applicable local, state and national codes.

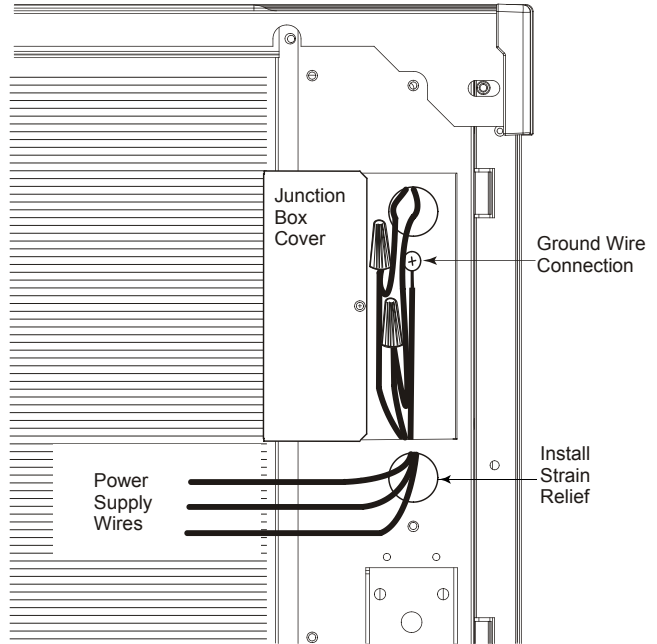

---

Electrical Connections, Back of Unit

**C0322 through C1030**  
**Air and Water Cooled User Manual**  
**Final Check List**

---

**After connections,**

1. Wash out the bin. If desired, the interior of the bin could be sanitized.
2. Locate the ice scoop (if supplied) and have it available for use when needed.

**Final Check List:**

1. Is the unit located indoors in a controlled environment?
2. Is the unit located where it can receive adequate cooling air?
3. Has the correct electrical power been supplied to the machine?
4. Have all the water supply connections been made?
5. Have all the drain connections been made?
6. Has the unit been leveled?
7. Have all unpacking materials and tape been removed?
8. Is the correct switch bezel installed in the trim strip?
9. Is the water pressure adequate?
10. Have the drain connections been checked for leaks?
11. Has the bin interior been wiped clean or sanitized?
12. Have any water filter cartridges been replaced?
13. Have all required kits and adapters been properly installed?

**C0322 through C1030**  
**Air and Water Cooled User Manual**  
**Initial Start Up**

---

1. Remove front panel and evaporator cover. Check machine for any packing or wires rubbing moving parts. Note location of control board in upper left corner of the machine's front.
2. Switch on the electrical power to the machine. Observe that some of the control's indicator lights glow and its display shows *D*.
3. Open the water supply valve.
4. Push and release the ON button. The code display will begin to blink *F*.

The purge valve opens, the water pump starts and the inlet water valve opens to add water to the reservoir. In a few seconds the purge valve closes and the water pump stops. Water will flow into the machine until the reservoir is full. The hot gas valve and harvest assist device will activate, then the compressor and water pump will start. If it's an air cooled model the fan motor(s) will begin to turn a few moments after the compressor starts. The display will show a continuous *F*. Five seconds later the hot gas valve will close and the harvest assist device will return to its standby position. Warm air will be discharged from air cooled models.

5. Observe the Ready for Harvest indicator light. It may blink early in the cycle, that is normal. The control will ignore that signal for the first 6 minutes of freeze.
6. During the Freeze cycle move the curtain and observe that the SW1 or SW2 light on the control board blinks On when the curtain moves away from the evaporator and Off when returned to its normal position.

---

Note: Moving the curtain during the Freeze cycle has no affect on control function, but will cause water to flow into the cube chute.

---

7. When enough ice has frozen, the Ready for Harvest indicator light will be on steady. After it's been on steady for a few seconds Harvest will begin.

The display shows an *H*. The hot gas valve opens, the air cooled fan motor(s) shut off and the harvest assist

mechanism is activated. The purge valve opens to drain some water, when it does the inlet water valve opens to refill the reservoir. After a few seconds the purge valve closes but the inlet water valve continues to fill the reservoir. Harvest continues until the ice is released as a unit and forces the curtain to open. When the curtain opens it signals the controller which returns the unit to a freeze cycle.

8. Check the ice harvested for proper bridge thickness. The ice bridge is factory set at 1/8 inch. If needed, adjust bridge thickness. Do NOT make it too thin.
9. Return the front panel and evaporator cover to their normal positions and secure to the machine.
10. Instruct the user in the operation of the machine and its maintenance requirements.
11. Fill out and mail the warranty registration form or register it on line at Scotsman-ice.com.

**Typical Ice Making Cycle Times (minutes).**

Listed times are for clean machines in proper installations. Cycle length at startup will be longer until the system stabilizes.

Model	70°F air / 50°F. water	90°F. air / 70°F. water
C0322A	10-12	14-16
C0322W	9-11	10-12
C0522A	11-13	16-18
C0522W	13-15	13-15
C0330A	9-11	12-14
C0330W	8-10	9-11
C0530A	12-14	16-18
C0530W	10-12	11-13
C0630A	9-11 1	1-13
C0630W	7-9	10-12
C0722A	13-15	19-22
C0830A	10-12	13-15
C0830W	11-13	12-14
C1030A	9-11	11-13
C1030W	9-11	10-12

**C0322 through C1030**  
**Air and Water Cooled User Manual**  
**Adjustments**

**Bridge Thickness - For the Service Tech Only**

1. Push and hold Off till the machine stops.
2. Remove evaporator cover.
3. Remove curtain.
4. Use a hex wrench and rotate the bridge thickness adjustment screw in 1/8 turn increments CW to increase bridge thickness. Rotate CCW to decrease bridge thickness.

Caution: Do not make the bridge too thin or the machine will not harvest properly. Bridge thickness adjustments are not covered by warranty.

5. Return curtain and evaporator cover to their normal positions.
6. Push and release the On button. Check next harvest of ice. Repeat steps 1-6 if needed.

**Water Purge Setting**

The water purge is factory set to the automatic position, suitable for most water conditions. The setting can be changed to one of 5 manual settings or left on automatic.

Purge setting	1 - Minimum	2 - Moderate	3 - Standard	4 - Heavy	5 - Maximum	A - Automatic
Water Type	RO water or equivalent	Low TDS non - RO water	Use for typical water	High TDS water	Very High TDS water	Any with conductivity not less than 10 microSiemens/cm

To set:

1. Switch the machine OFF by holding the Off button in until a number or the letter A shows on the display.
2. Press and release the On button repeatedly until the number on the display corresponds to the desired setting.
3. Press and release the Off switch again to return to the normal control state.

**Ice Bridge Thickness Measurement**

Note: Indentations may be deeper on C0322 and C0330

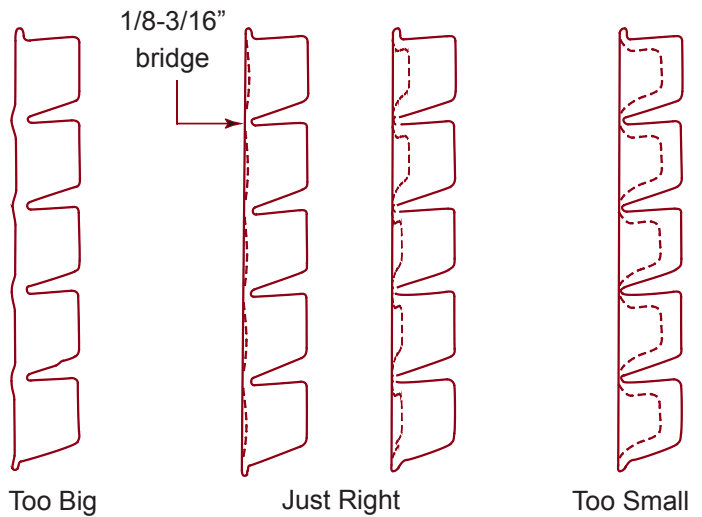

**Bridge Thickness Adjustment Mechanism**

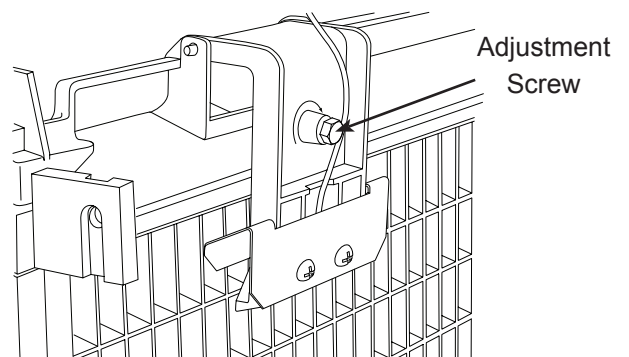

Note: Water cooled models, the refrigeration system discharge pressure is factory set at 245 PSIG, which should yield a freeze cycle discharge water temperature of about 105-110 degrees F. Adjust if necessary.



**C0322 through C1030**  
**Air and Water Cooled User Manual**  
**Use and Operation**

---

Once started, the ice machine will automatically make ice until the bin or dispenser is full of ice. When ice level drops, the ice machine will resume making ice.

Caution: Do not place anything on top of the ice machine, including the ice scoop. Debris and moisture from objects on top of the machine can work their way into the cabinet and cause serious damage. Damage caused by foreign material is not covered by warranty.

There are four indicator lights at the front of the machine that provide information on the condition of the machine.

Indicator Lights:

- Power
- Status
- Water
- De-scale & Sanitize

If the De-Scale light is on, the machine has determined that it needs to be cleaned. Contact an authorized Scotsman service agent and have the machine cleaned, de-scaled and sanitized.

Note: A Component Indicator Light switches ON to indicate that the component is operating.

---

Note: There are two Curtain Switch lights, SW1 and SW2. These single plate models have one curtain switch light on all the time, as a curtain switch light is ON when a curtain is either open or not present.

---

	Indicator Lights & Their Meanings			
	Power	Status	Water	De-Scale & Sanitize
Steady Green	Normal	Normal – bin full or making ice	-	-
Blinking Green	Self Test Failure	Switching on or off	-	-
Blinking Red	-	Diagnostic shutdown or, if making ice, temperature sensor failure	Lack of water	-
Yellow	-	-	-	Time to de-scale and sanitize
Blinking Yellow	-	-	-	In Cleaning mode
Light off	No power	Switched off	Normal	Normal

All Blinking Unit remotely locked out – check with leasing company

If the Water light is on, the machine has sensed a lack of water. Check the water supply to the machine. The water could have been shut off or the water filter cartridges might need to be changed.



# C0322 through C1030

## Air and Water Cooled User Manual

### Control Switches

The On and Off switch buttons are front accessible.

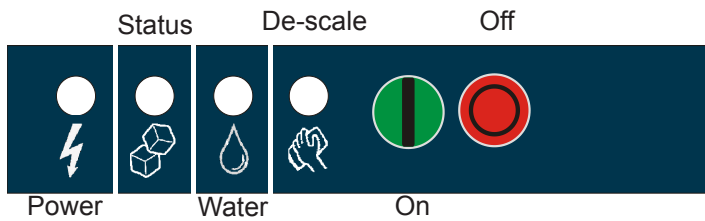

To switch the machine OFF, push and release the Off button. The machine will shut off at the end of the next cycle. To shut the machine off immediately, push and hold the Off button for 3 seconds.

To switch the machine ON, push and release the On button. The machine will go through a start up process and then resume ice making.

#### Control Options

There are three optional, field installed controls that can be added to this machine.

- Vari-Smart™ adjustable ice level control
- Smart-Board™ advanced control board and data logger

#### Adjustable ice level control, kit # KVS

When this option is present there is an adjustment post and an additional indicator light to the right of the four indicator lights mentioned above. The ultrasonic ice level control allows the user to control the point that the ice machine will stop making ice before the bin or dispenser is full. Reasons for this include:

- Seasonal changes in ice used
- Planning to sanitize the bin
- Faster turnover for fresher ice
- Certain dispenser applications where maximum ice level is not desired

#### Use of control



There are several positions the ice level can be set to, including Off or Max (knob and label indicators lined up), where it fills the bin until the standard bin control shuts the machine off. See the kit's instructions for complete details.

Rotate the adjustment post to the desired ice level. The machine will fill up to that level and when it shuts off the indicator light next to the adjustment post will be On.

---

Note: Ice will build up in the bin or dispenser at an angle, the distance set will be from the sensor to the top of the ice. The sensor position is shown in the cabinet layout diagrams.

---

The actual distance between the highest point of the ice may be closer or further away than the distance set, depending upon the angle of the ice.

# C0322 through C1030

## Air and Water Cooled User Manual

### Options

---

#### Advanced Feature Board, kit #KSBU

When this option is present there is an additional display panel in the area below the main control board. It is not visible when the front panel is on.

The Smart-Board's features include:

- Seven day programmable ice level setting when used with the optional Ultrasonic ice level control
- Recording of machine operation, including cycle time.
- Calculation of average cycle time
- Recall of malfunctions with the time they occurred.

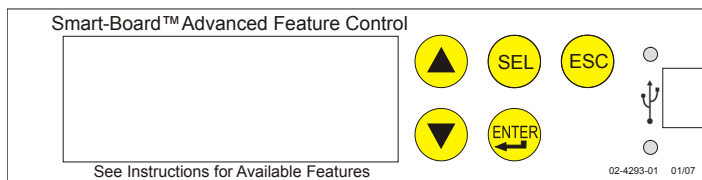

#### Ice

The cuber drops ice in large sections. That ice will break up into random parts as it falls into the bin, but some large sections may remain on top of the ice in the bin. When removing ice, tap the groups of ice with an ice scoop to separate them into smaller units. In a dispenser, this ice will break up into mostly individual cubes as the dispense mechanism moves the ice.

The ice in the bin will normally slope down from the right to the left.

#### Heat

Air cooled models will generate heat when in operation. That heat is discharged out the back of the cabinet.

#### Noise

The ice machine will make noise when it is in ice making mode. The compressor, fan motor(s) if air cooled and water pump all produce some sound. It is also normal to hear some cracking just before the harvest cycle begins. In addition, during the harvest cycle the harvest assist solenoid will click twice as it pushes the ice out and returns to its normal position. The ice harvests as a unit or slab, which makes some noise when it impacts the bin or dispenser. These noises are all normal for this machine.

# C0322 through C1030

## Air and Water Cooled User Manual

### Cleaning, Sanitation and Maintenance

---

This ice system requires three types of maintenance:

- Remove the build up of mineral scale from the ice machine's water system and sensors.
- Sanitize the ice machine's water system and the ice storage bin or dispenser.
- Clean or replace the air filter and clean the air cooled condenser (air cooled models only).

It is the User's responsibility to keep the ice machine and ice storage bin in a sanitary condition. Without human intervention, sanitation will not be maintained. Ice machines also require occasional cleaning of their water systems with a specifically designed chemical. This chemical dissolves mineral build up that forms during the ice making process.

Sanitize the ice storage bin as frequently as local health codes require, and every time the ice machine is cleaned and sanitized.

The ice machine's water system should be cleaned and sanitized a minimum of twice per year.

1. Remove the front panel.
2. Remove the evaporator cover.
3. If the machine is operating, push and release the Harvest button. When the machine completes the Harvest cycle it will stop. If the bin is full (b shows in display) push and release the Off button.
4. Remove all ice from the storage bin or dispenser.
5. Push and release the Clean button. The yellow Clean light will blink and the display will show c. The machine will drain the reservoir and refill it. Go onto the next step when the reservoir has filled.
6. Pour 8 ounces of Scotsman Clear 1 ice machine scale remover into the reservoir.
7. Allow the ice machine scale remover to circulate in the water system for at least 10 minutes.
8. Push and release the Clean button again. The yellow Clean light will be on continuously and the machine will drain and refill the reservoir repeatedly to

purge out the ice machine scale remover and residue.

9. Allow the drain and refill process to continue for at least 20 minutes.

10. Push and release the Off button. The clean cycle will stop and the display will show d.

---

Note: If unit has not been de-scaled for an extended period of time and significant mineral scale remains, repeat steps 5-10.

---

11. Mix a cleaning solution of 1 oz of ice machine scale remover to 12 ounces of water.

12. Locate curtain, push in on edge of curtain by pivot pin to release it. Pull curtain out of machine.

<b>CAUTION</b>	Ice machine cleaner contains acids. Acids can cause burns.
	If concentrated cleaner comes in contact with skin, flush with water. If swallowed, do NOT induce vomiting. Give large amounts of water or milk. Call Physician immediately. Keep out of the reach of children.

Push Here

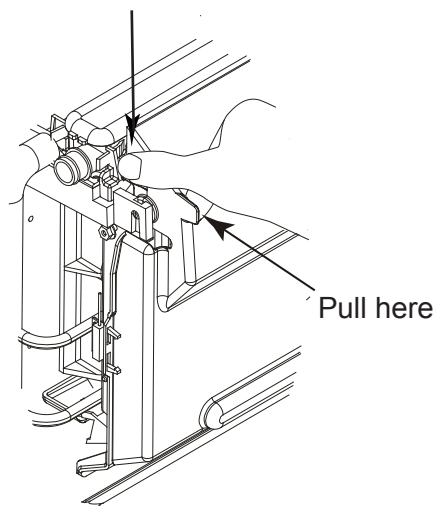

## C0322 through C1030

### Air and Water Cooled User Manual

13. Remove water distributor from ice machine.

Inspect distributor for restricted orifice holes. Be sure all holes are fully open.

Squeeze Tabs Together, Slide Out Until it Stops, Then Lift to Remove

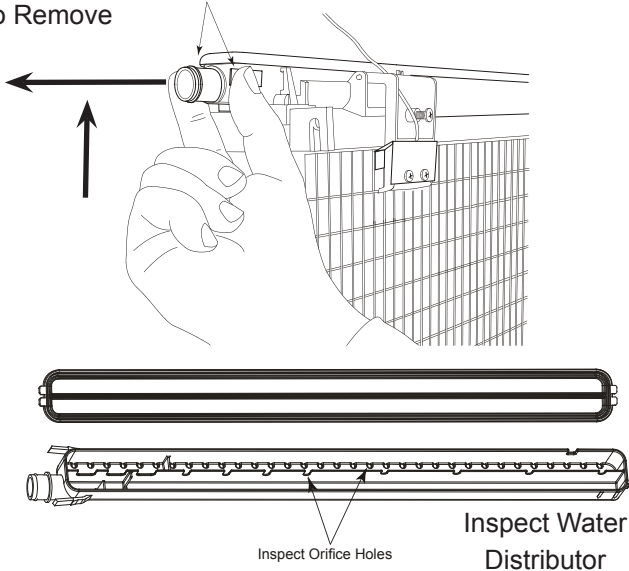

14. Locate ice thickness sensor. Squeeze mounting legs together to release sensor. Wash the metal surfaces of the sensor and the adjustment screw with ice machine scale remover solution. Also wash the water distributor and curtain with the ice machine cleaner solution.

15. Locate water level sensor. Squeeze catches together and pull up to remove sensor. Separate probes from housing and wash all surfaces with ice machine scale remover solution. Return probes to holder.

16. Remove sump cover from unit.

17. Create a solution of sanitizer by mixing a 2 gallon or 8 liter solution of locally approved sanitizer and clean, warm water. Use an EPA approved food equipment sanitizer at the solution mix recommended by the sanitizer manufacturer.

Release probes by pushing in on white buttons and pulling probe down out of holder.

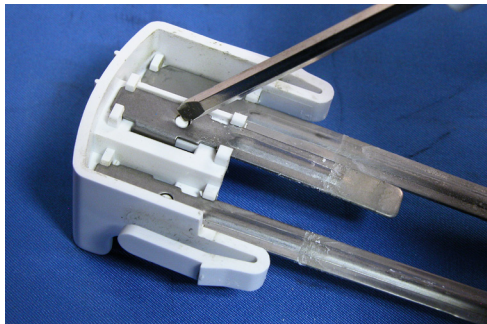

A possible sanitizing solution may be made up by using one 2 oz packet of Stera Sheen Green Label sanitizer (available from Scotsman) and 2 gallons of clean, potable 95°F. to 115°F. water.

18. Thoroughly wash all surfaces of the ice thickness sensor, water level sensor, sump cover, curtain and water distributor with the sanitizer solution.

19. Wash all interior surfaces of the freezing compartment, including evaporator cover and right side panel liner with the sanitizer solution.

20. Return water level sensor, ice thickness sensor, water distributor, sump cover and curtain to their normal positions.

21. Push and hold the clean button to drain the reservoir. Push and release the clean button again and when the purge valve indicator light goes out, immediately pour the remaining cleaning solution into the reservoir.

22. Circulate the sanitizer solution for 10 minutes, then push and release the Clean button.

23. Allow the water system to be flushed of sanitizer for at least 20 minutes, then push and release the Off button.

24. Return the evaporator cover and front panel to their normal position and secure with the original fasteners.

25. Wipe reservoir wall and other cabinet areas clean.

26. Push and release the On button to resume ice making.

### Ice Storage Bin

1. Remove and discard all ice.
2. Mix a solution of 7 ounces of Scotsman Clear 1 ice machine scale remover in 84 ounces of potable water and wash all interior surfaces of the ice storage bin to remove any mineral scale build up. Pour excess cleaner solution into the bin's drain.
3. Mix a solution of sanitizer and thoroughly wash all interior surfaces of the ice storage bin. Pour excess sanitizer solution into the bin's drain.

**C0322 through C1030**  
**Air and Water Cooled User Manual**  
**Air cooled condenser filter**

---

1. Pull air filter(s) forward from side panel.

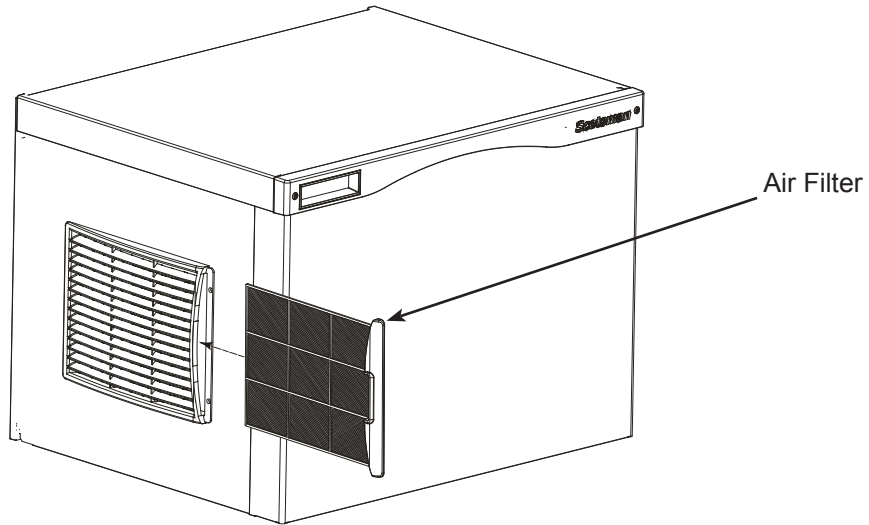

2. Wash the dust and grease off the filter.
3. Return it to its original position.

Do not operate the machine without the filter in place except during cleaning.

### **Air cooled condenser**

If the machine has been operated without a filter the air cooled condenser fins will need to be cleaned.

They are located under the fan blades. The services of a refrigeration technician will be required to clean the condenser.

### **Exterior Panels**

The front, top and side panels are durable stainless steel. Fingerprints, dust and grease will require cleaning with a good quality stainless steel cleaner.

Note: If using a sanitizer or a cleaner that contains chlorine on the panels, after use be sure to wash the panels with clean water to remove chlorine residue.

### **Water filters**

If the machine has been connected to water filters, check the cartridges for the date they were replaced or for the pressure on the gauge. Change cartridges if they've been installed more than 6 months or if the pressure drops too much when the ice machine fills with water.

**C0322 through C1030**  
**Air and Water Cooled User Manual**  
**What to do before calling for service**

---

**Reasons the machine might shut itself off:**

- Lack of water.
- Freeze cycle takes too long.
- Harvest cycle takes too long.
- High discharge temperature.
- Controller self test failure.

**Check the following:**

1. Has the water supply to the ice machine or building been shut off? If yes, the ice machine will automatically restart within 25 minutes after water begins to flow to it.
2. Has power been shut off to the ice machine? If yes, the ice machine will automatically restart when power is restored.
3. Has someone shut the water off to a water cooled unit? If yes, after the water supply has been restored the ice machine may need to be manually reset.
4. Is the curtain open because some ice is stuck under it? If so, remove the ice and the machine should start in a few minutes.

---

Note: Curtain can be removed & replaced anytime the machine is in a standby mode or when it is in a freeze cycle. However, removal of the curtain during freeze will result in water flowing into the bin. Removal of the curtain during harvest terminates harvest at that point and, if left off, will result in the machine shutting off.

---

**To Manually Reset the machine.**

- Push and release the Off button.
- Push and release the On button.

**To Shut the Machine Off:**

1. Push and hold the Off button for 3 seconds or until the machine stops.

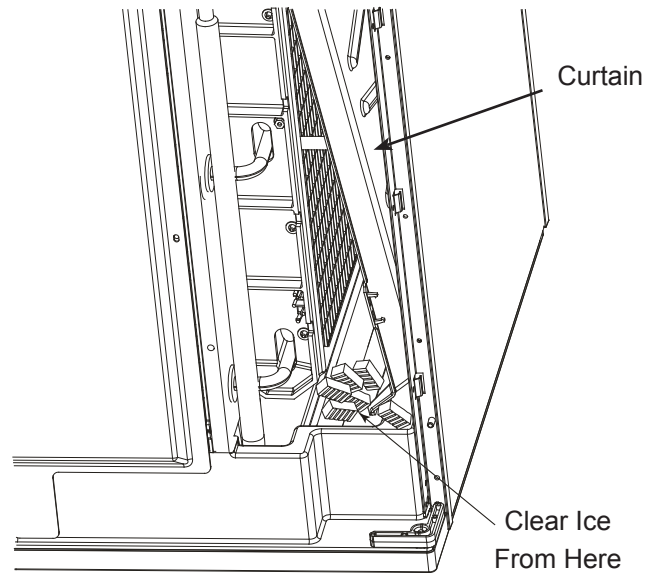

---

Clear Ice From Beneath Curtain

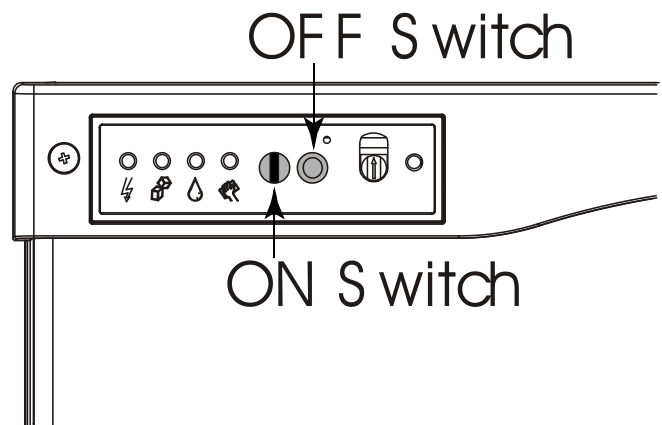

---

Reset or Switch Off

# **SCOTSMAN ICE SYSTEMS**

775 Corporate Woods Parkway

Vernon Hills, IL 60061

[www.scotsman-ice.com](http://www.scotsman-ice.com)

800-726-8762