

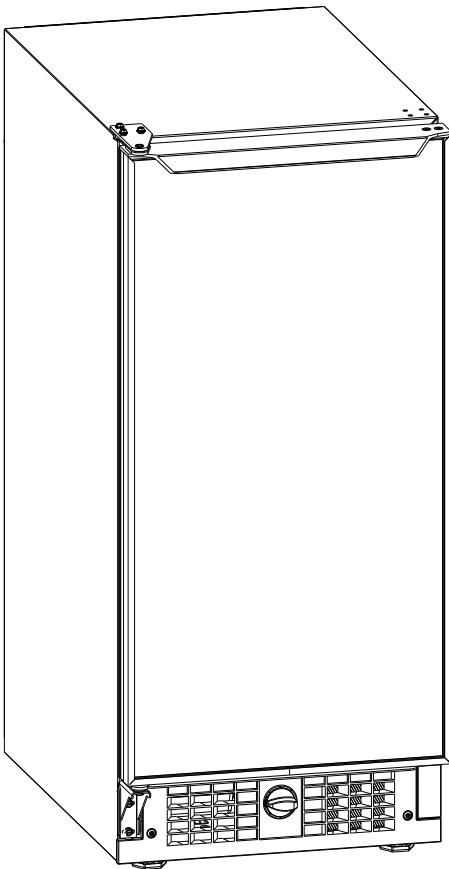

Installation and User's Manual  
for Refrigerator  
Model **SCR33**



**SCR33**  
**User's Manual**

**Introduction**

---

Congratulations on your purchase of a Scotsman refrigeration product.

For future reference, keep this guide in a safe, accessible location. If you need additional information or assistance, please contact your seller or Scotsman directly. Contact information appears on the back cover of this guide.

Table of Contents

Specifications . . . . .	Page 2
General Information . . . . .	Page 3
Installation . . . . .	Page 4
Dimensions . . . . .	Page 5
Door Swing . . . . .	Page 6
Door Alignment and Adjustment . . . . .	Page 7
Door Swing Change Instructions . . . . .	Page 8
Leveling Information . . . . .	Page 9
Air Flow . . . . .	Page 10
Removing and Installing Interior Shelves . . . . .	Page 11
Removing and Installing Grille . . . . .	Page 12
Maintenance . . . . .	Page 13
Condenser Cleaning . . . . .	Page 14
Service . . . . .	Page 15
Service Diagnosis . . . . .	Page 16
Service Parts . . . . .	Page 17
Wiring Diagram . . . . .	Page 18

**SCR33**  
**User's Manual**  
**Specifications**

---

**Capacity**

- 2.9 cubic feet.

**Adjustable tempered glass shelves.**

- Sleek, streamlined interior. Allows flexible shelf locations to meet varying food and beverage storage needs.

**Two adjustable in-door storage shelves**

- Easily accessible storage area right where you need it most. Adjustable to allow flexible storage options

**Built-in or freestanding**

- Provides custom look when built-in with no additional venting clearance needed on sides, top or rear.

**Flat recessed grille**

- Blends with and integrates with surrounding cabinetry.

**Mechanical Temperature Control**

- Provides ability to set and accurately maintain the temperature.

**Vinyl-clad cabinet**

- Textured, rich appearance. Resistant to scratching, peeling and flaking.

**Field-reversible doors**

- Flexible installation options.

**Adjustable leveling legs**

- Achieve a more precise under counter fit. Durable, strong legs will not bend when unit is installed.

**For indoor use only.**

Scotsman Ice Systems are designed and manufactured with the highest regard for safety and performance. They meet or exceed the standards of agencies like UL.

Scotsman assumes no liability or responsibility of any kind for Scotsman brand products that have been altered in any way, including the use of any parts and/or other components not specifically approved by Scotsman.

Scotsman reserves the right to make design changes and/or improvements at any time. Specifications and designs are subject to change without notice.

# SCR33

## User's Manual

### General Information

---

#### IMPORTANT

PLEASE READ all instructions before installing, operating, or servicing the appliance.

Proper installation procedures must be followed when completing an installation or relocation of a unit. Consult the installation guide before any installation begins. Scotsman contact information appears on the rear cover of this guide.

This unit requires connection to a dedicated 15 Amp grounded polarized receptacle (three-prong), installed by a qualified electrician and compliant with applicable electrical codes.

#### Safety Alert Definitions

Throughout this guide are safety items labeled with a Danger, Warning or Caution based on the risk type:

**DANGER** - Danger means that failure to follow this safety statement will result in severe personal injury or death.

**WARNING** - Warning means that failure to follow this safety statement could result in serious personal injury, property or equipment damage.

**CAUTION** - Caution means that failure to follow this safety statement may result in minor or moderate personal injury, property or equipment damage.

#### General Precautions

Use this appliance for its intended purpose only and follow these general precautions with those listed throughout this guide:

#### **DANGER**

**RISK OF CHILD ENTRAPMENT.** Before you throw away your old refrigerator or freezer, take off the doors and leave shelves in place so children may not easily climb inside.

**WARNING SHOCK HAZARD** - Electrical Grounding Required.

Never attempt to repair or perform maintenance on the unit until the electricity has been disconnected.

Never remove the round grounding prong from the plug and never use a two-prong grounding adaptor.

Altering, cutting of power cord, removal of power cord, removal of power plug, or direct wiring can cause serious injury, fire and or loss of property and or life, and will void the warranty.

Never use an extension cord to connect power to the unit.

Always keep your working area dry.

#### **CAUTION**

Use care when moving and handling the unit. Use gloves to prevent personal injury from sharp edges.

If your model requires defrosting, **DO NOT** use an ice pick or other sharp instrument to help speed up defrosting. These instruments can puncture the inner lining or damage the cooling unit. **DO NOT** use any type of heater to defrost. Using a heater to speed up defrosting can cause personal injury and damage to the inner lining.

#### IMPORTANT

- Do not lift unit by door handle.
- Never install or operate the unit behind closed doors.
- Be sure front grille is free of obstruction. Obstructing free airflow can cause the unit to malfunction and will void the warranty.
- Failure to clean the condenser every six months can cause the unit to malfunction. This could void the warranty.
- Do NOT start the refrigerator for 8 hours if it has been tipped on its side during unpacking.
- Allow unit temperature to stabilize for 24 hours before use.
- Do Not block the airflow at the front.

# SCR33

## User's Manual

### Installation

Your unit has been designed for either free-standing or a built-in installation. When built-in, your unit does not require additional air space for top, sides or rear. However, the front grille must NOT be obstructed and clearance is required for an electrical connection in the rear.

#### CAUTION

Unit can NOT be installed behind a closed cabinet door.

#### WARNING

**SHOCK HAZARD** — Electrical Grounding Required.

Never remove the round grounding prong from the plug and never use a two-prong grounding adapter.

Never use an extension cord to connect power to the unit.

#### IMPORTANT

Electrical installation must observe all state and local codes. This unit requires connection to a grounded (three prong), polarized receptacle that has been placed by a qualified electrician.

The unit requires a grounded and polarized 115 VAC, 60 Hz, 15A power supply (normal household current). An individual, properly grounded branch circuit or circuit breaker is recommended. GFCI (ground fault circuit interrupter) is usually not required for fixed location appliances and is not recommended for your unit because a GFCI could be prone to nuisance tripping. However, be sure to consult your local codes.

#### Cut-Out Dimensions

Follow the cut-out drawing. The 15-1/4" width allows 1/4" for ease in installation and removal of the unit. 24" is the cabinet depth in most installations.

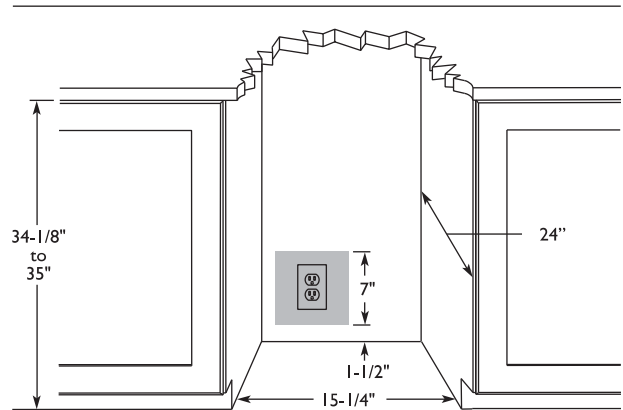

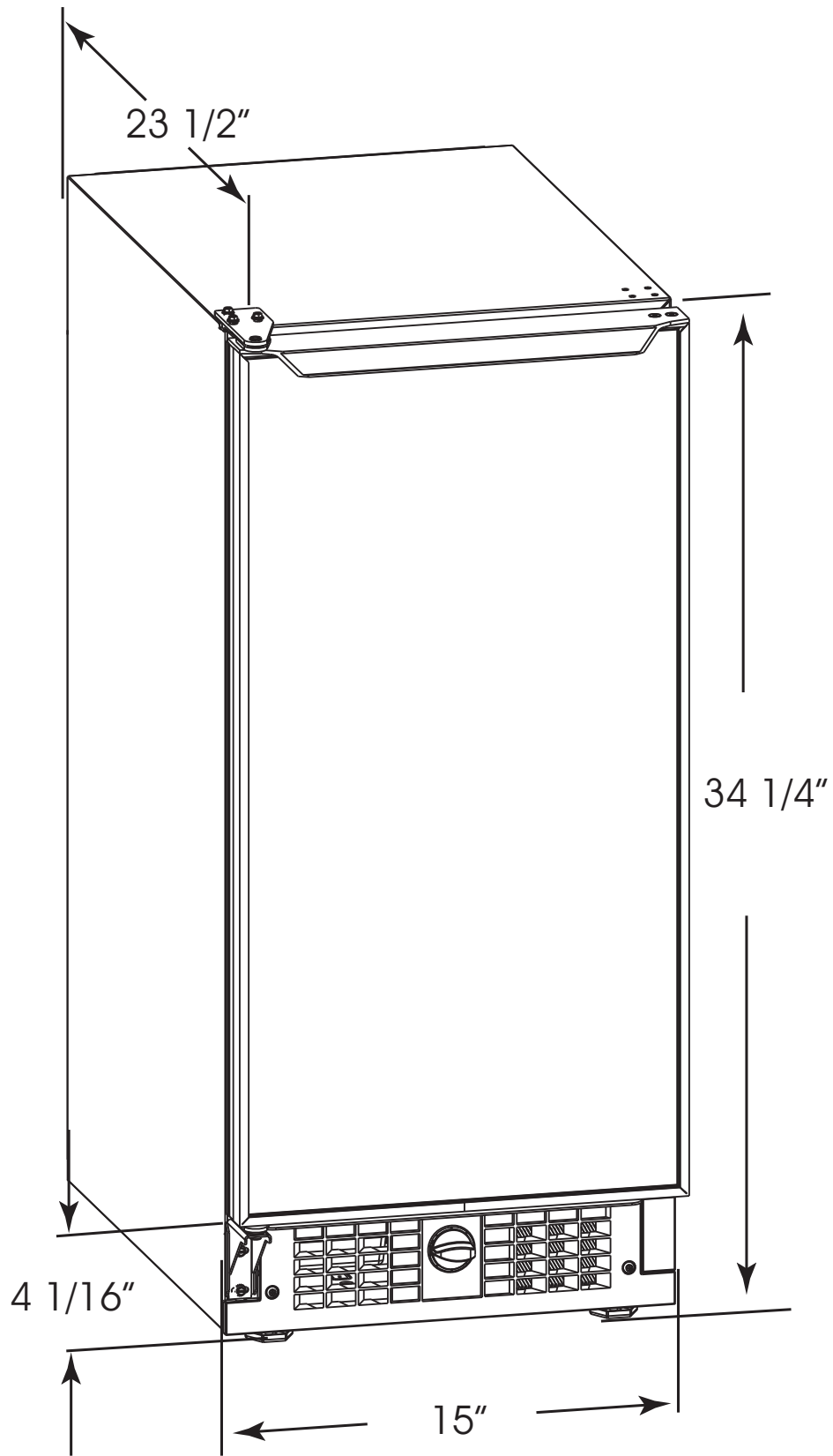

# SCR33 User's Manual

## Door Swing

### Door Swing Dimensions

Your unit has a zero clearance for the door to open 90°. Scotsman recommends a minimum door clearance of 2" to accommodate the handle if the unit is installed next to a wall or similar type of structure.

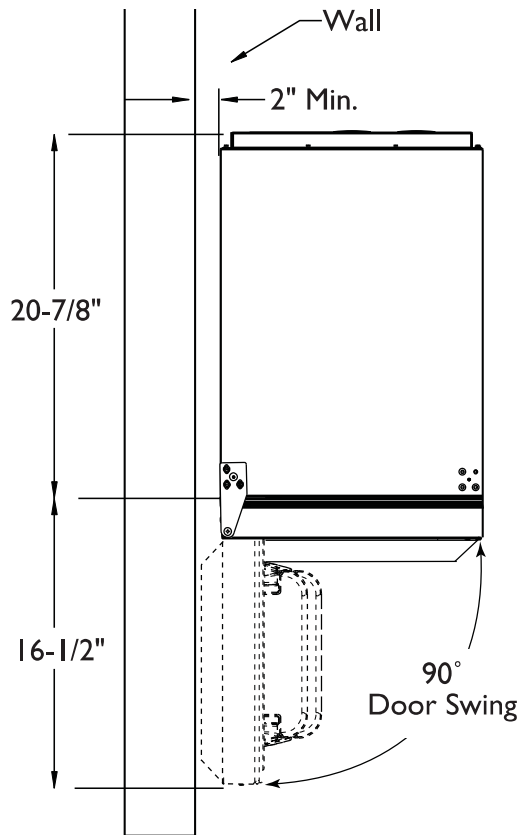

### Environmental Requirements

The units are designed to operate between 50°F (10°C) and 100°F (37°C). High ambient temperatures (100°F [37°C] or higher) may reduce the unit's ability to reach low temperatures.

For best performance, keep the unit out of direct sunlight and away from heat generating equipment.

In climates where high humidity and dew points are present, condensation may appear on outside surfaces. This is considered normal. The condensation will disappear when the humidity drops.

## **Door Alignment and Adjustment**

Align and adjust the door if it is not level, or is not sealing properly.

If the door is not sealed the unit may not cool properly, or excessive frost may form in the interior.

### **IMPORTANT**

Properly aligned, the door's gasket should be firmly in contact with the cabinet all the way around the door (no gaps). Carefully examine the door's gasket to assure that it is firmly in contact with the cabinet. Also make sure the door gasket is not pinched on the hinge side of the door.

To align and adjust the door:

1. Loosen (do not remove) top and bottom hinge screws.
2. Align door squarely with cabinet.
3. Make sure gasket is firmly in contact with cabinet all the way around the door (no gaps).
4. Tighten bottom hinge screws.
5. Tighten top hinge screws.

## **Door Swing Change**

Location of the unit may make it desirable to mount the door on the opposite side of the cabinet.

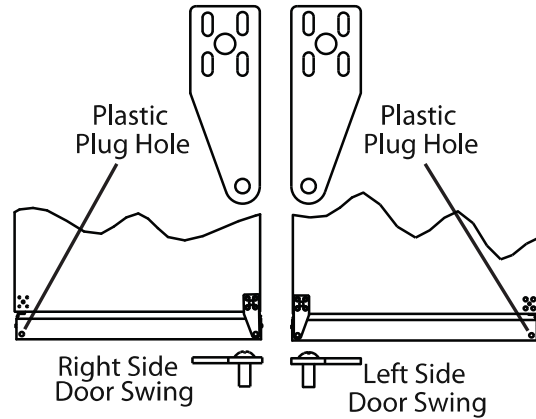

### **Reversing the door**

The Hinge hardware will be removed and reinstalled on the opposite side of the cabinet.

The top hinge plate is flipped over when it is reinstalled on the opposite side of the cabinet.



**SCR33**  
**User's Manual**

**Door Swing Change Instructions**

Remove top hinge, and door:

1. Hold door to keep it from falling.
2. Remove top hinge from cabinet by removing the three screws.

3. Remove door by tilting forward and lifting door off bottom hinge.

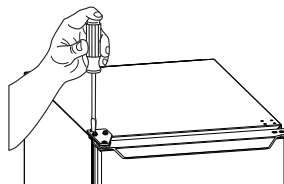

4. Remove the three plastic screw plugs from hinge holes on the opposite side. Reinstall into holes where the hinge was removed.

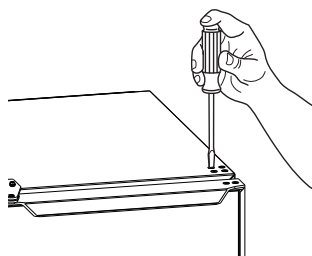

Ensure not to scratch cabinet.

**Remove Grille**

1. Disconnect power to the unit.
2. Remove control knob (2).

3. Remove the two grille mounting screws (1).

4. Remove grille (3) from unit.

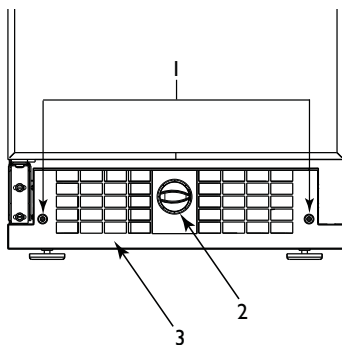

Remove bottom hinge:

1. Remove bottom hinge from cabinet.
2. Remove corresponding screws on opposite side of cabinet.

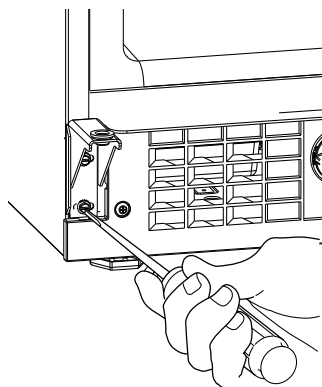

Install bottom hinge:

1. Align hinge outer edge with cabinet

2. Reinstall the two screws.

Prepare door for reinstallation:

1. Remove plastic hole plug from top of door handle and reinstall on opposite side.

2. Remove plastic hinge bushing on bottom of door and reinstall on opposite side. Clean out bushing hole in door bottom with a screwdriver if necessary.



Install top hinge, and door:

1. Remove the pivot pin from the top hinge plate.
2. Install the hinge plate to the correct side of your unit.

3. Install 3 screws to hinge plate.

4. Lift the door on to the bottom hinge.

5. Push door under top hinge plate.

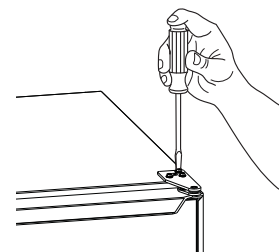

Align pivot pin hole with pivot pin bushing on door.

6. Install top hinge plate pivot pin.

Align and adjust the door:

1. Align and adjust the door, see DOOR ALIGNMENT AND ADJUSTMENT on page 7.

Install grille:

1. Place the hook-hinge located on the rear bottom side of the grille (3) onto the front lip of the unit base. Swing the grille up into position.

2. Align cabinet and grill holes and secure, but do not overtighten grille screws (1).

3. Install control knob (2).

4. Reconnect power to the unit.

# SCR33

## User's Manual

### Leveling Information

It is recommended that the unit is level.

1. Use a level to check the levelness of the unit from front to back and from side to side. Level should be placed along top edge and side edge as shown

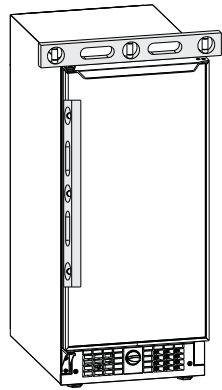

2. If the unit is not level, adjust the feet on the corners of the unit as necessary.

3. Check the levelness after each adjustment and repeat the previous steps until the unit is level.

#### INSTALLATION TIP

If the room floor is higher than the floor in the cut-out opening, adjust the rear feet to achieve a total unit rear height of 1/8" less than the opening's rear height. Shorten the unit height in the front by adjusting the front feet. This allows the unit to be gently tipped into the opening. Readjust the front feet to level the unit after it is correctly positioned in the opening.

#### Turn Foot To Adjust Height

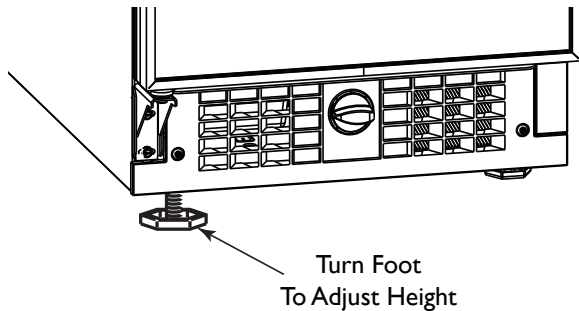

#### Installation

1. Plug in the power cord.
2. Gently push the unit into position. Be careful not to entangle the electrical cord.

3. Re-check the leveling, from front to back and side to side. Make any necessary adjustments. The unit's top surface should be approximately 1/8" below the countertop.

4. Remove the tape from the glass shelves and wipe out the inside of the unit with a clean, water-dampened cloth.

#### Relocating the Shelves

Both the glass shelves in the refrigerator and the inner door shelves can be moved to accommodate your bottles, cans and containers.

#### Glass Shelves

Open door fully, grasp shelf firmly, lift front edge slightly, and pull straight out.

Choose new location and slide shelf onto the appropriate rib.

#### Door Shelves

First pull shelf up at a 45° angle, then straight out.

Choose new location and line up on bosses. First push straight in, then down at a 45° angle.

#### Installation Troubleshooting

Q: Problem

The door remains open unless it is pushed closed.

A: Solution

Re-check leveling from front to back of the unit and readjust if necessary. Make sure the pivot plate is installed correctly.

**Air Flow**

**IMPORTANT**

The unit requires proper air flow to perform at its highest efficiency. Do not block the front grille or internal fans at any time, or the unit will not perform as expected. Do not install the unit behind a door.

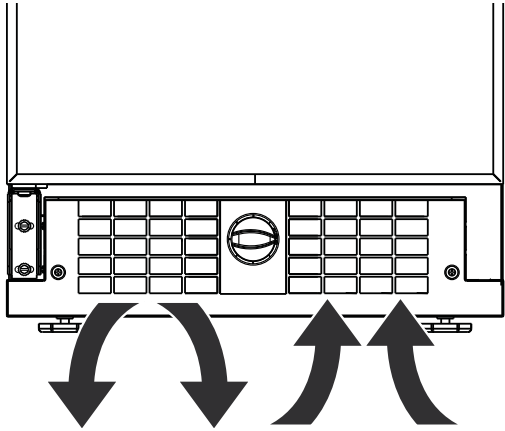

**Initial Startup**

All Scotsman controls are preset at the factory. Initial startup requires no adjustments.

**IMPORTANT**

Scotsman recommends allowing the unit to run overnight before loading refrigerator with product.

To turn the unit on:

Turn the control dial found in the center of the grille to a MID setting, number 3 or 4 on the controller knob.

To turn the unit off, turn the control dial counterclockwise until hearing a “click”. It may take some force to get the control to “click”.

**Control Dial**

The control dial sets a single continuous set-point temperature.

This set point is for the middle zone, it is a base number used by the controller to maintain the multiple temperature zones in the unit. The factory default MID setting set-point is 38°F. The setpoint temperature is a gauge for further temperature adjustments.

**Adjusting Air Temperature**

**IMPORTANT**

Adjust the set point temperature in small increments, and wait 24 hours for the temperature to stabilize before rechecking.

Factory recommended set-point is MID setting on dial control.

To adjust the set point temperature:

1. Adjust the temperature by turning the control knob in small increments.
2. Allow temperature to stabilize for 24 hours before adjusting again.

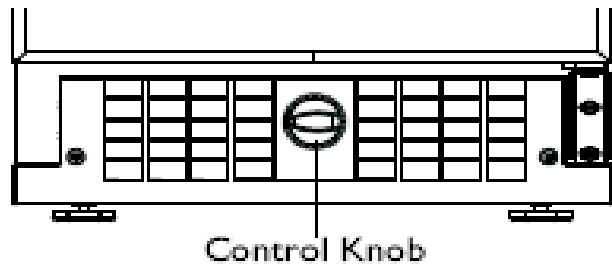

**Checking Product Temperature**

To check the actual product temperature in the unit.

1. Partially fill a plastic (nonbreakable) bottle with water.
2. Insert an accurate thermometer.
3. Tighten the bottle cap securely.
4. Place the bottle in the desired area for 24 hours.
5. Avoid opening the unit during the testing period.
6. After 24 hours, check the temperature of the water. If required, adjust the temperature control in a small increments (See ADJUSTING TEMPERATURE).

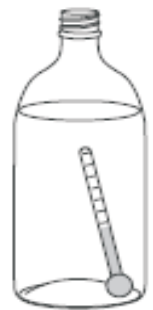

### Removing and Installing Interior Shelves

1. Pull shelf out about 6" (1), until back of shelf clears the rib on the right-hand side.
2. Tilt up right-hand edge of shelf (2).
3. Remove shelf from unit by pulling out (3).

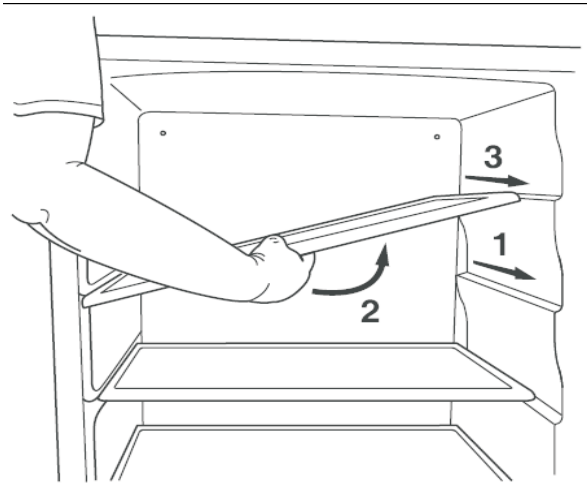

Insert the shelves as follows:

1. To move to a different position in the unit, insert shelf at an angle, approximately 15-20°, over the rib in the side of the unit where you want to place the shelf. Place the shelf into the unit at an angle to clear the door.
2. Continue to slide the shelf into the unit at an angle until it clears the door.

Lower the shelf and push it in completely. Ensure the raised edge strip is toward the rear of the unit.

#### IMPORTANT

Make sure the shelves are inserted fully into the unit.

### Removing and Installing Door Shelves

To remove the door shelf:

1. Grasp shelf in center, and lift until the shelf notches (1) clear the pins (2).
2. Carefully pull the shelf away from the door.

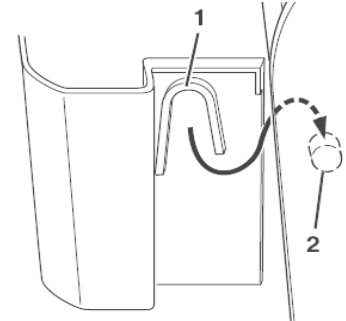

To install the door shelf:

1. Holding the shelf in the center, center the shelf in the door at the desired location, slightly above the pins (2).
2. Lower the shelf onto the pins (2).

# SCR33

## User's Manual

### Removing and Installing Grille

---

#### WARNING

Disconnect electric power to the unit before removing the grille.

#### WARNING

DO NOT touch the condenser fins. The condenser fins are SHARP and can be easily damaged.

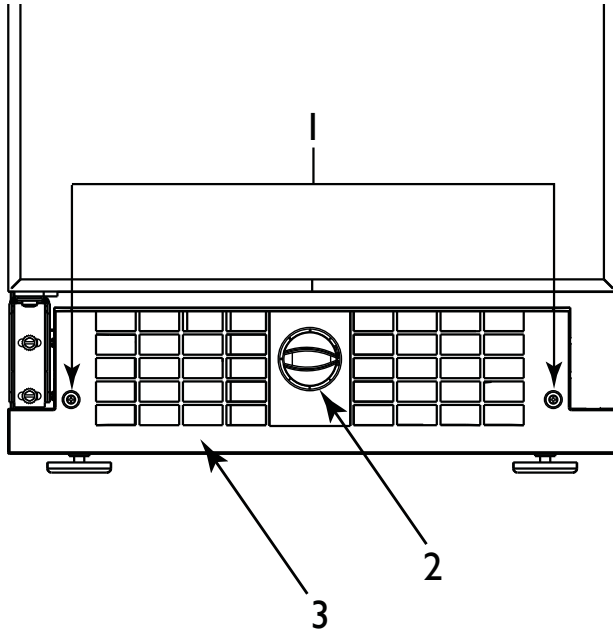

#### Installing grille:

1. Place the hook-hinge located on the rear bottom side of the grille (3) onto the front lip of the unit base. Swing the grille up into position.
2. Align cabinet and grill holes and secure, but do not overtighten grille screws (1).
3. Install control knob (2).
4. Reconnect power to the unit.

#### Removing the grille.

1. Disconnect power to the unit.
2. Remove control knob (2).
3. Loosen the two screws (1).
4. Remove grille (3) from unit.
5. Reconnect power to the unit.

# SCR33

## User's Manual

### Maintenance

---

#### Exterior Cleaning

Clean surfaces with a mild detergent and warm water solution.

Do not use solvent-based or abrasive cleaners.

Use a soft sponge and rinse with clean water.

Wipe with a soft, clean towel to prevent water spotting.

#### Interior Cleaning

Disconnect power to the unit.

Clean the interior and all removed components using a mild nonabrasive detergent and warm water solution applied with a soft sponge or non-abrasive cloth.

Rinse the interior using a soft sponge and clean water.

Do not use any solvent-based or abrasive cleaners. These types of cleaners may transfer taste to the interior products and damage or discolor the interior.

#### Defrosting

##### Automatic Defrost

Frost on the rear wall is normal and will melt during each off cycle.

If there is excessive build-up of 1/4" or more, manually defrost the unit.

Ensure the door is closing and sealing properly.

High ambient temperature and excessive humidity can also produce frost.

#### CAUTION

DO NOT use an ice pick or other sharp instrument to help speed up defrosting. These instruments can puncture the inner lining or damage the cooling element. DO NOT use any type of heater to defrost. Using a heater to speed up defrosting can

cause personal injury and damage to the inner lining.

#### IMPORTANT

The drain pan was not designed to capture the water created when manually defrosting. To prevent water from overflowing the drain pan, place towels or other absorbent materials over the interior drain trough, under the evaporator (1), before defrosting.

#### Manual Defrost:

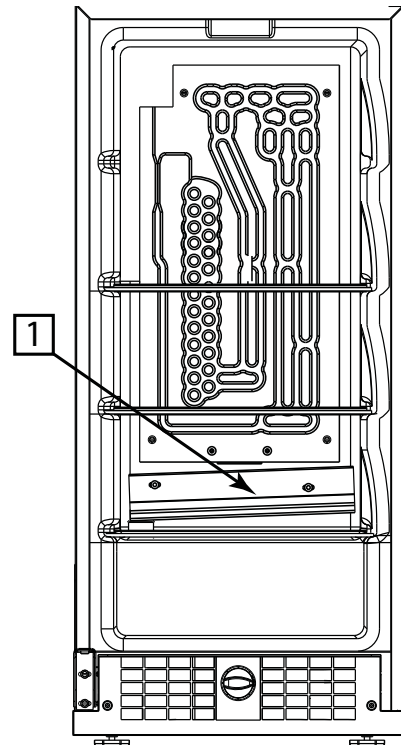

1. Disconnect power to the unit.
2. Remove all products from the interior.
3. Prop the door in an open position (2 in. (5 cm) minimum).
4. Allow the frost to melt naturally.
5. After the frost melts completely clean the interior and all removed components. (See INTERIOR CLEANING)
6. When the interior is dry, reconnect power and turn unit on.

**Condenser Cleaning**

Interval - Every Six Months

To maintain operational efficiency, keep the front grille free of dust and lint, and clean the condenser every six months. Depending on environmental conditions, more or less frequent cleaning may be necessary.

**WARNING**

Disconnect electric power to the unit before cleaning the condenser.

**WARNING**

DO NOT touch the condenser fins. The condenser fins are SHARP and can be easily damaged.

**IMPORTANT**

DO NOT use any type of cleaner on the condenser unit.

1. Remove the grill.
2. Clean the condenser coil (1) using a using a soft brush with a "combing" action or vacuum cleaner. Do not touch the condenser coil.

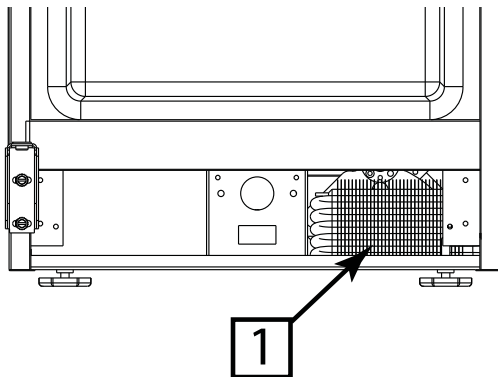

3. Install the grill.

**Storage, Vacation and Moving**

If not using the unit for an extended period, or otherwise stored, follow these steps completely:

**WARNING**

Electrical Shock Hazard. Disconnect power before servicing. Before operating, replace all panels. Failure to do so may result in death or electrical shock.

**IMPORTANT**

If the ambient temperature is expected to drop below 50°F, turn off and unplug unit, and drain all water from the unit to prevent freezing damage.

1. Remove all consumable contents from the unit.
2. Disconnect the power cord from its outlet, and leave it disconnected until the unit is returned to service.
3. Clean and dry the interior of the cabinet.
4. During periods of non-use, the cabinet must remain open to prevent formation of mold and mildew. Open door a minimum of 2 in. (5 cm) to provide the necessary ventilation.

**Product Disposal**

If the unit is being removed from service for disposal, check and obey all Federal, State and Local regulations regarding the disposal and recycling of refrigeration appliances. Follow these steps completely:

1. Remove all consumable contents from the unit.
2. Disconnect power to the unit and unplug the power cord from its outlet.

**DANGER**

**RISK OF CHILD ENTRAPMENT.** Before you throw away your old refrigerator or freezer, take off the doors and leave shelves in place so children may not easily climb inside.

3. Remove the cabinet door.

**Service**

---

**Normal Operating Sounds**

Listed below are common refrigeration components with brief description of the normal operating sounds they make.

**Compressor:** The compressor makes a hum or pulsing sound that may be heard when it operates.

**Evaporator:** Refrigerant flowing through an evaporator may sound like boiling liquid.

**Condenser Fan:** Air moving through a condenser may be heard.

**Automatic Defrost Drain Pan:** Water may be heard dripping or running into the drain pan when the unit is in the defrost cycle.

**Before Calling for Service**

If you think your product is malfunctioning, see page 10 for temperature adjustments.

If the problem persists, read the NORMAL OPERATING SOUNDS and Service Diagnosis section of this guide to help you quickly identify common problems, and possible causes and remedies. Most often, this will resolve the problem without the need to call for service.

**If Service is Required**

If you do not understand a troubleshooting remedy, or your product needs service, contact your dealer or Scotsman directly. Contact information appears on the rear cover of this guide.

When you call, you will need your product model and serial numbers. It also appears on the model and serial number plate located on the upper right or rear wall of the interior of your product.

**Replacement Parts**

When you need replacement parts, always request genuine Scotsman replacements. Scotsman designs and engineers products using components that work efficiently, and provide superior service life and performance. The use of aftermarket parts or components may affect the safety, operation, performance or durability of your product, and may also void its warranty.



**SCR33**  
**User's Manual**  
**Service Diagnosis**

Problem	Possible Cause and Remedy
Unit Develops Frost on Internal Surfaces.	<p>Frost on the rear wall is normal and will melt during each off cycle. If there is excessive build-up of 1/4" or more, manually defrost the unit.</p> <p>Ensure the door is closing and sealing properly.</p> <p>High ambient temperature and excessive humidity can also produce frost.</p>
Unit Develops Condensation on External surfaces	<p>The unit is exposed to excessive humidity, moisture will dissipate as humidity levels decrease.</p>
Product is Freezing.	<p>Product in contact with the rear cooling element may freeze, ensure no product is touching the rear wall.</p> <p>Adjust the temperature to a warmer set-point.</p>
Product is Not Cold Enough.	<p>Air temperature does not indicate product temperature.</p> <p>Adjust the temperate to a cooler set-point.</p> <p>Ensure unit is not located in excessive ambient temperatures or in direct sunlight.</p> <p>Ensure the door is closing and sealing properly.</p> <p>Ensure nothing is blocking the front grille, found at the bottom of the unit.</p> <p>Ensure the condenser coil is clean and free of any dirt or lint build-up.</p>
Unit switches on and off frequently	<p>Not enough product in the cabinet. Add bottles of liquid to displace air in unit.</p>

**SCR33**  
**User's Manual**  
**Service Parts**

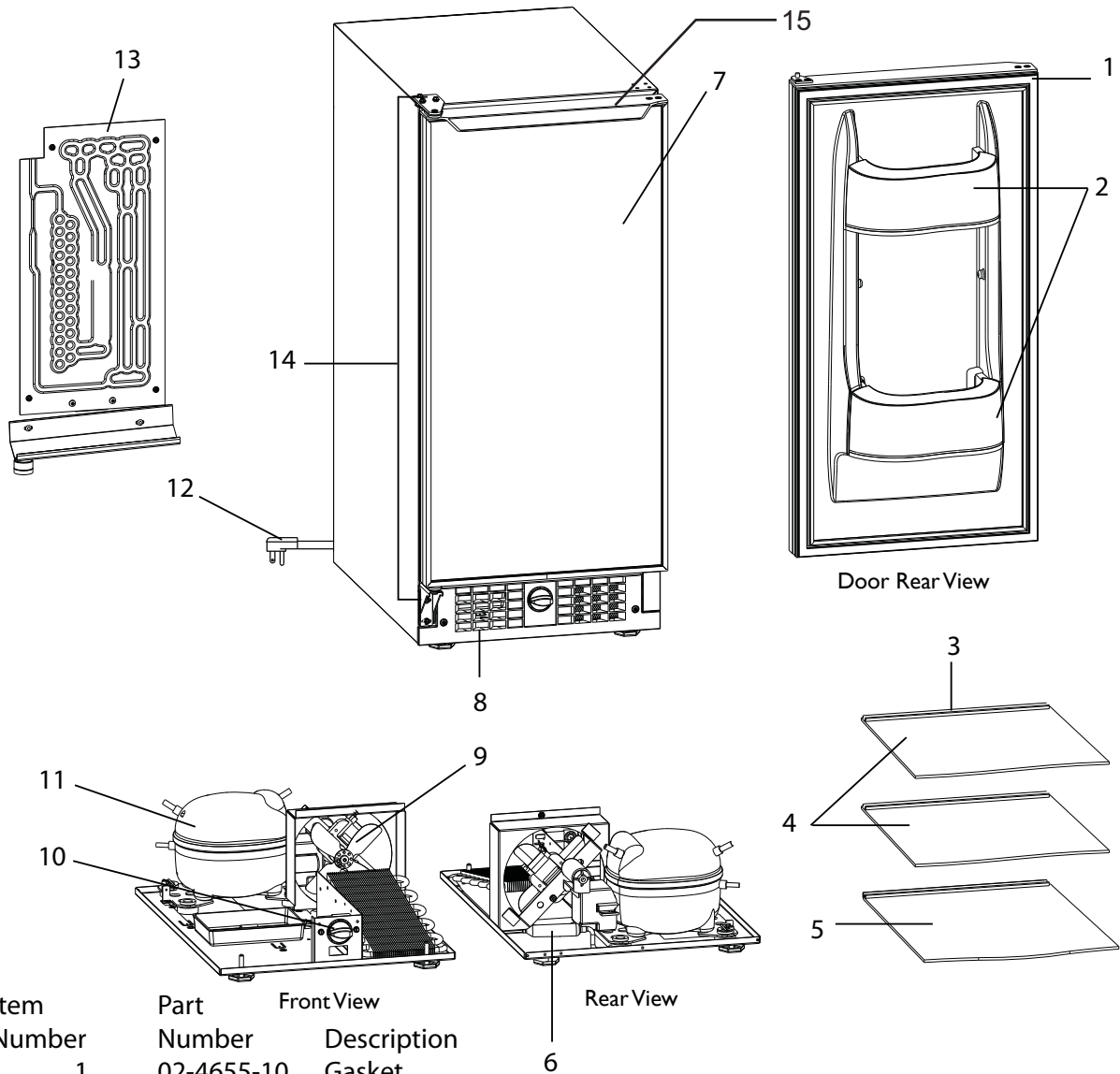

Item Number	Part Number	Front View Description	Rear View
1	02-4655-10	Gasket	
2	02-4655-04	Door shelf	
3	02-4655-08	Edge trim	
4	02-4655-05	Shelf	
5	02-4655-11	Crisper	
6	02-4655-02	Dryer	
7	02-4655-12	Hinge assembly	
8	02-4655-14	Grill	
9	02-4655-16	Fan motor and blade	
	02-4655-03	Fan blade	
10	02-4655-07	Control	
11	02-4655-06	Compressor	
12	02-4655-01	Power cord	
13	02-4655-09	Evaporator	
14	02-4655-13	Door	
15	15-0731-03	Label, door handle	

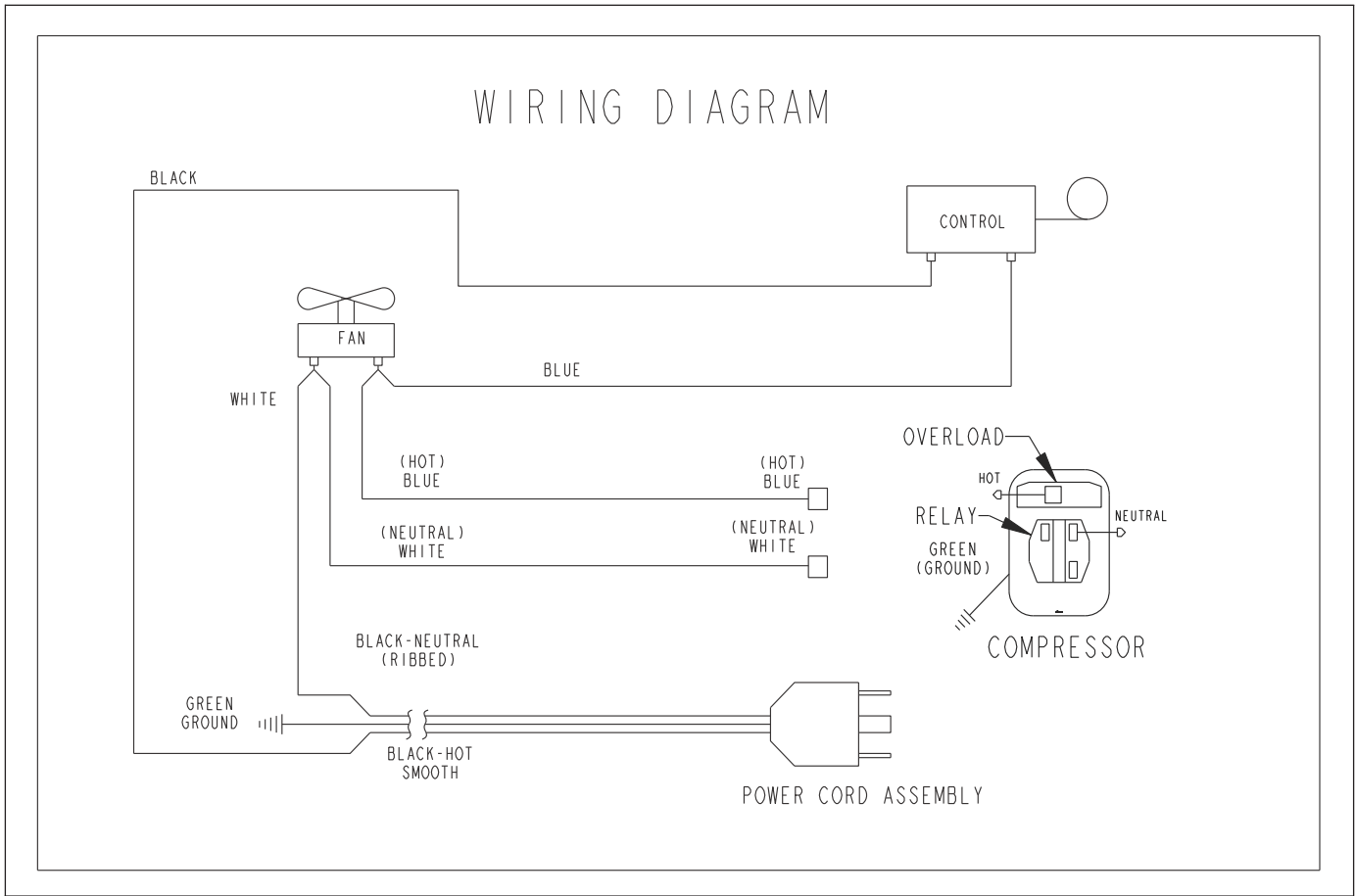

Compressor Winding Resistance: at 72 degrees F.  
Start: 21.2 Ohms  
Run: 7.9 Ohms

# SCOTSMAN ICE SYSTEMS

775 Corporate Woods Parkway,

Vernon Hills, IL 60061

800-726-8762

[www.scotsman-ice.com](http://www.scotsman-ice.com)